

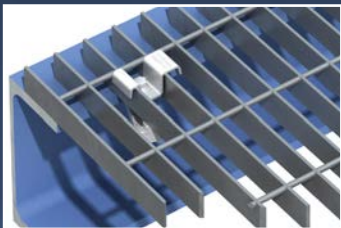

Edge Construction Supply

Authorized Lindapter Distributor

Technical Innovation in Steel Connections



lindapter[®] **USA**

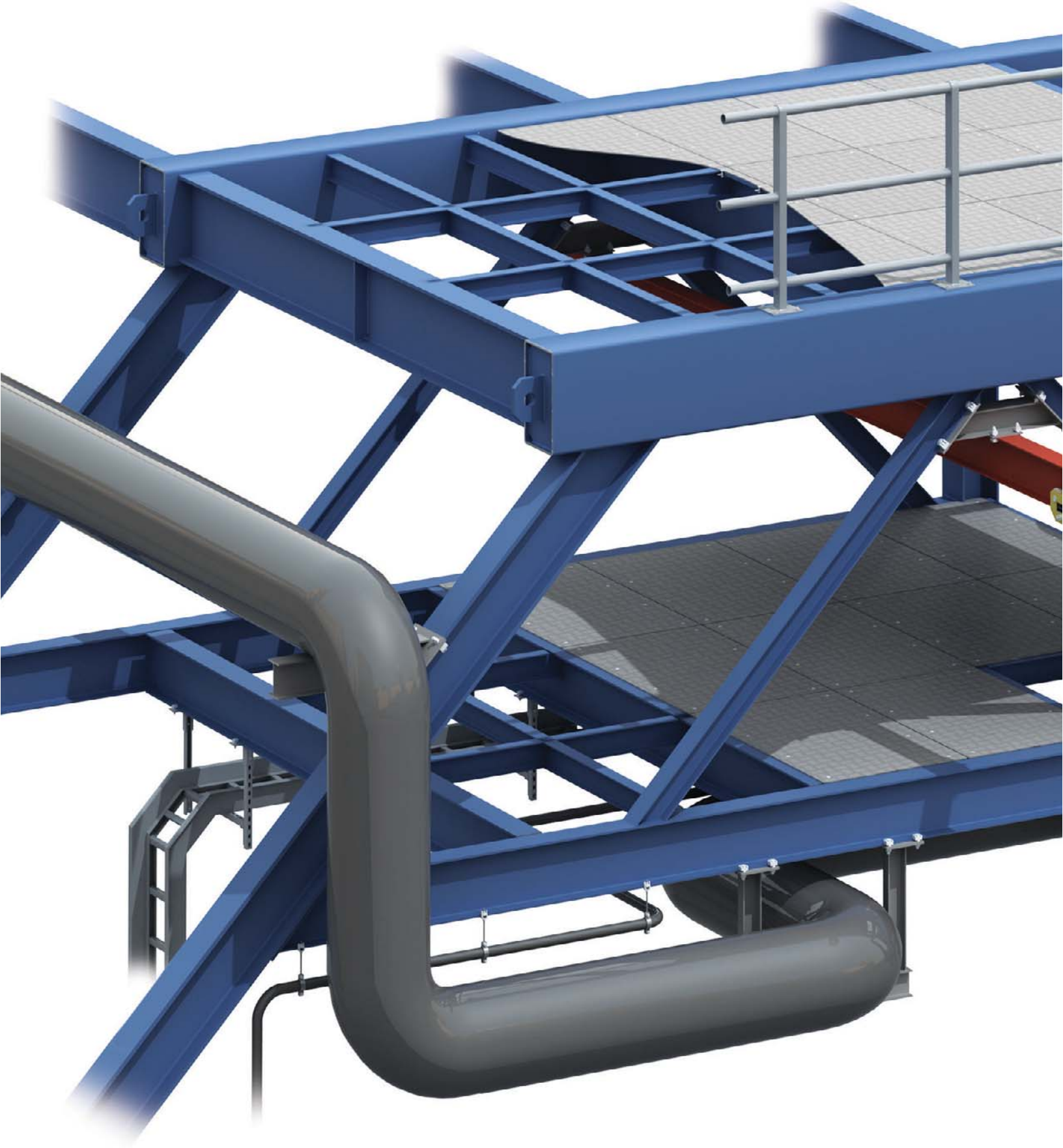



For more than 75 years, Lindapter has earned a respected reputation as the inventor and pioneer of steel clamping systems, providing an independently approved and exclusive product range of steel, hollow structural section (HSS), concrete decking, pipe / conduit supports and steel floor connections.



Founder Henry Lindsay

Lindapter's unique connections create significant advantages in comparison to traditional methods such as welding or drilling, including the reduction of installation time and labor costs, on-site adjustability and no damage to steel sections or protective coatings.

The company's proud heritage began in 1934 when Engineer Henry Lindsay invented an entirely new concept of connecting steel with the Lindsay Bolt Adapter, allowing simple, fast clamping, instead of often difficult and time consuming drilling or welding. The idea was to revolutionize millions of future connections on countless projects worldwide and the combination of the two words 'Lindsay' and 'Adapter' explains the formation of the now famous brand name.



Today, the world's best Engineers choose Lindapter for projects as varied as Rome Train Station, Gatwick Airport, Alexander Hamilton Bridge, Dubai Shopping Mall and Gautrain Rapid Rail Link. Whether joining primary structural sections, securing secondary beams or suspending building services, Lindapter has a proven and trusted solution.

Lindapter has passionately grown since 1934 from a modest family business into a reputable global brand and strives to continue its proud heritage; to invent and deliver 'Technical Innovation in Steel Connections'.

For further information:

- Service and Support (page 6)
- Quality and Approvals (page 7)



The large illustration opposite shows examples of Lindapter connections.



www.LindapterUSA.com

Introduction 2
 Index 4
 Service and Support 6
 Quality and Approvals 7



1 Steel Connections

Introduction 8
 Girder Clamps 10
 Loads and Specifications 11
 Type A 12
 Type B 13
 Accessories for Type A and B 14
 Plate and Packing Details for Type A and B 15
 Type AF 16
 Type CF 17
 Accessories for Type AF 18
 Plate and Packing Details for Type AF and CF 19
 Type LR 20
 Type D2 and D3 21
 Accessories for Type LR, D2 and D3 22
 Plate and Packing Details for Type LR, D2 and D3 23
 Type LS 24
 Accessories, Plate and Packing Details for Type LS 25
 Type BR and RC 26
 Accessories and Packing Details for Type BR 27
 Type HD 28
 Type BSNT and BSLN 30
 Type F9 and HW/HC 31
 Type SC and LP 32
 Type FC - Flush Clamp 33
 Typical Applications 34

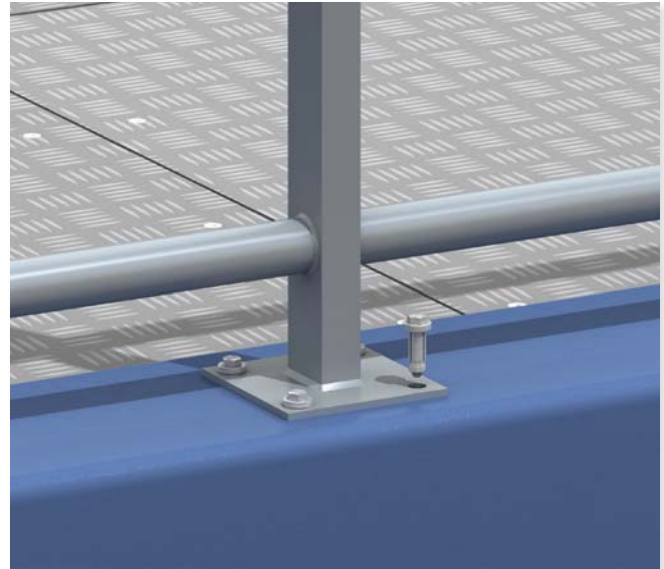

2 Hollow Section (HSS) Connections

Introduction 38
 Type HB - Hollo-Bolt® 39
 • High Clamping Force (HCF) 40
 • Design Data 42
 • Installation Guidance 44
 • Typical Applications 46
 Type LB2 - Lindibolt™ 2 49



3 Concrete Decking Connections

Introduction 50
 Type TC and VN 51





4 Pipe / Conduit Supports

Introduction.....	52
Type FLS.....	53
Type FL.....	54
Type LC and SW - Swivel Unit.....	55
Type F3 and F3-BICC.....	56
Type HW/HC and Z10.....	57

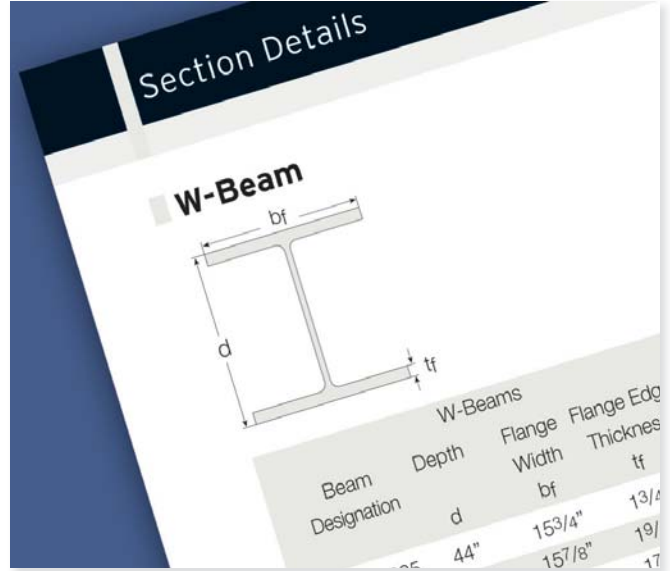

6 Appendix

Section Details.....	61
Projects.....	64

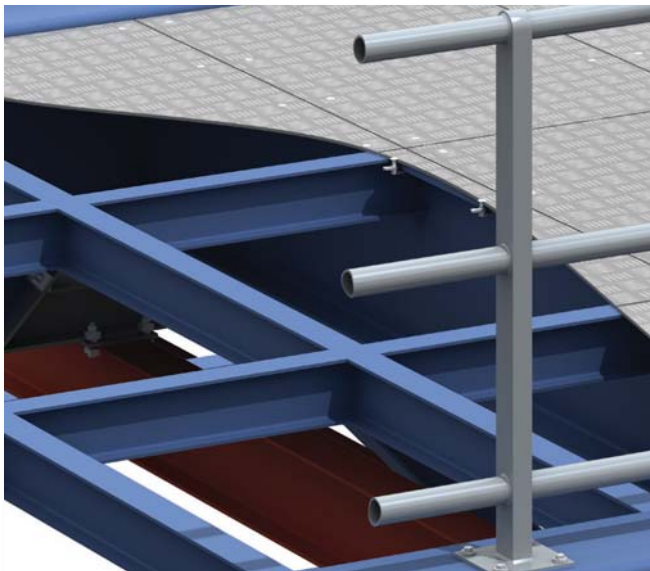

5 Steel Floor Connections

Introduction.....	58
Type FF - Floorfast®.....	59
Type GF - Grate-Fast®.....	60

Disclaimer:

Lindapter International supplies components in good faith, on the assumption that customers fully understand the loadings, safety factors and physical parameters of the products involved. Customers or users who are unaware or unsure of any details should refer to Lindapter International before use. Responsibility for loss, damage, or other consequences of misuse cannot be accepted. Lindapter makes every effort to ensure that technical specifications and other product descriptions are correct. 'Specification' shall mean the specification (relating to the use of the materials) set out in the quotation given by the Seller to the Buyer. Responsibility for errors or omissions cannot be accepted. All dimensions stated are subject to production tolerances - if in doubt please check with Lindapter. In the interests of improving the quality and performance of Lindapter products, we reserve the right to make specification changes without prior notice.

LINDAPTER, HOLLO-BOLT, FLOORFAST, GRATE-FAST etc., are all registered trademarks. Lindapter may also have trademark rights in other terms used herein.

© Lindapter International 2013

Lindapter International is Lindapter's Global Headquarters, located at Lindsay House, Brackenbeck Road, Bradford, BD7 2NF, England.

Applications

All the applications featured in the catalog are based on real projects. More information can be found on the website: www.LindapterUSA.com

Research and Development

To meet the needs of an ever-changing world, Lindapter's R&D department is constantly developing innovative new products. The team is supported by the latest technology including 3D modeling, rapid prototyping, finite element analysis, in addition to two in-house 224,800 lbs hydraulic test machines.

Lindapter works in collaboration with respected companies and organizations such as Tata Steel Europe® (formerly Corus), Mannesmann, The Steel Construction Institute, CIDECT as well as many leading universities and approval bodies.



Technical Support

The comprehensive technical support from Lindapter's experienced Engineers ensures an efficient specification process with a free design service and bills of materials upon request. Lindapter's philosophy is to deliver the highest quality at every stage of the service, from initial connection design to installation guidance.

- Free connection design based upon your requirement
- Optimized solution for cost and performance
- Bespoke drawings delivered in 2D and interactive 3D formats
- CAD files for import into major software applications
- Contractor training
- 3D Assembly PDFs

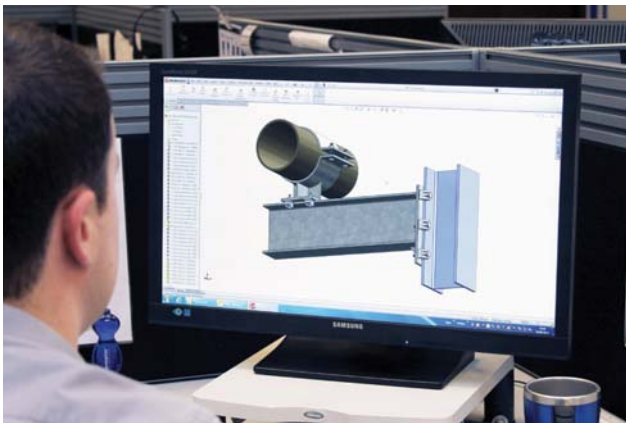

Engineered Solutions

Lindapter's unique expertise and R&D capability facilitates a custom product development service, passionately referred to as 'Engineered Solutions'. The Type 1055 is an example of a product invented and manufactured for a customer; the stainless steel floor connection was developed specifically for Amec / Shell, for fitting solid plate to open-grid flooring to offshore platforms.

The service offered to clients includes:

- Design and development of custom products
- Full strength and performance analysis
- Thoroughly tested with detailed reports
- Manufactured to Lindapter's exacting standards



Type 1055,
an Engineered Solution

Corrosion Protection

Lindapter products are delivered either bright zinc plated or hot dip galvanized as standard. Various other coatings and alternative materials are available upon request for most products including:

- Sherardizing
- Galvanizing
- Plastic coating
- Special paint coating
- Delta seal
- Deltatone
- Sheraplex
- Stainless steel





Quality

Accredited to ISO 9001 since 1986, Lindapter strictly enforces a quality management system that includes vigorous product testing to ensure consistently high manufacturing standards.



Environment

Lindapter operates an ISO 14001 certified environmental management system and constantly monitors and improves aspects of the business that may have an impact on the environment, including the use of natural resources, the handling and treatment of waste, and energy consumption.



TÜV Nord

TÜV is the certifying authority for safety, quality and environmental protection in Germany.



Det Norske Veritas (DNV)

DNV has approved the use of Lindapter products in lifting applications. This includes their use on both mobile and fixed offshore installations.



Factory Mutual (FM)

FM, the American insurance organization, offers an approval that is recognized by the fire protection industry worldwide.



Verband der Schadenversicherer (VdS)

VdS e.V. is one of Germany's leading independent testing institutions for products used in fire protection applications.



Approvals

Lindapter has manufactured to the highest standard for over three quarters of a century, earning a multitude of independent approvals and a reputation synonymous with safety and reliability. Current accreditations awarded by international associations include the following:

CE Mark

For Lindapter products in compliance with the provisions of the EC Construction Products Directive 89/106/EEC, please refer to the website: www.lindapter.com/about/ce



Deutsches Institut für Bautechnik (DIBt)

DIBt is a body that approves construction products for use in structural and civil engineering industries in Germany.



Lloyd's Type Register Type Approval

Lloyd's Register Type Approved products have been subjected to tensile, frictional, vibration and shock tests, witnessed and verified by Lloyd's Register.



Associations

Lindapter is a member of the following organizations:



American Institute of Steel Construction



British Constructional Steelwork Association



The Steel Construction Institute



Southern African Institute of Steel Construction

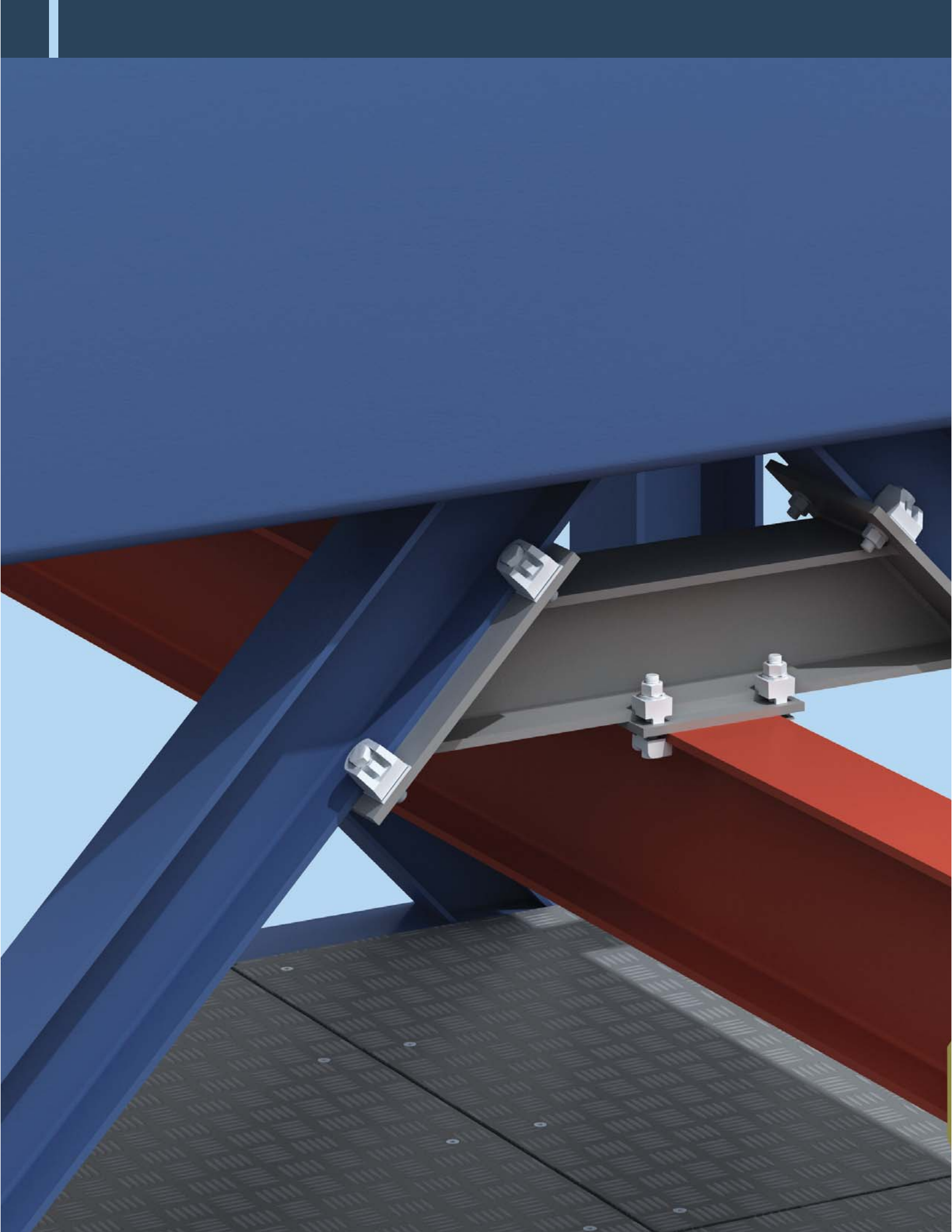

Steel Connections

Lindapter steel connections require no on-site drilling or welding, saving both time and money, and are compatible with virtually any size or shape of steel section in a wide variety of applications.

The Girder Clamp symbolizes Lindapter's concept perfectly; boldly challenging the need to drill or weld, when a safe, high strength connection can be quickly accomplished by clamping two steel sections together. Although the concept is simple, Lindapter products undergo complex design and testing as the experienced Research & Development team constantly refine, improve and invent to achieve greater product performance and safety approvals.

The connections shown throughout this catalog are actual applications from real project successes, both new construction and the refurbishment of existing structures.

Advantages

- Less design time (Lindapter will design the connection)
- Independently approved loads and quality standards
- No on-site drilling or welding
- Fast and safe construction
- 'Hot Working' not required
- Adjustable on-site
- Less work at height
- Only hand tools required to install
- Power not required
- Ability to deconstruct and multi-cycle

Markets include:

- Plant Engineering
- Chemical and Petrochemical
- Material Handling
- Structural Engineering
- Civil Engineering
- Façades
- Theatre Equipment
- Transportation
- Offshore

Applications include:

- Steel Construction
- Cranes
- Lifting Beams
- Pipe Supports
- Towers and Masts
- Almost any steel-to-steel connection



lindapter
USA

Components of a Girder Clamp

1. **Standard Grade 5 Hex Nut**
2. **Standard Hardened Washer**
3. **Lindapter Clamp**
Dependent on the application different clamps could be used, i.e. Types A, B, BR, AF, LR, LS.
4. **Packing Piece**
In combination with the clamps mentioned above, these parts increase the tail length to enable the product to sit correctly on the beam.
5. **Location Plate (can be supplied if required)**
This is an essential part of the girder clamp assembly that enables all the components to be located in the correct position. The hole centers and plate thickness are calculated to suit the individual application.
6. **Lindapter Clamp**
This can be of a similar type as component 3 (above), although certain products are designed to specifically work together, i.e. A + B.
7. **Standard SAE Grade 5 Hex Bolt or Setscrew**

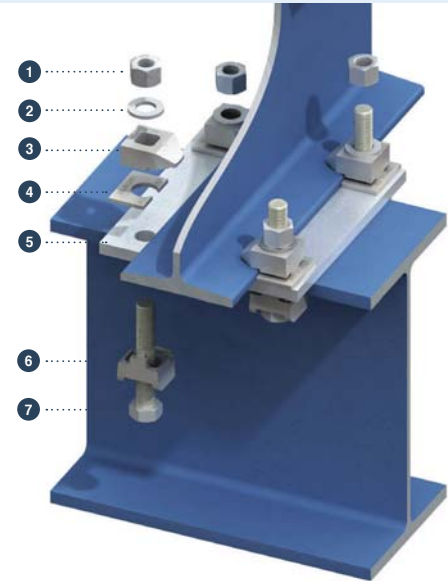

Bolt length calculation for a standard Lindapter Girder Clamp,

Showing 3/4" Type A and B as an example

To calculate the bolt length, all parts the bolt will go through have to be added up. The next standard bolt length should be used.

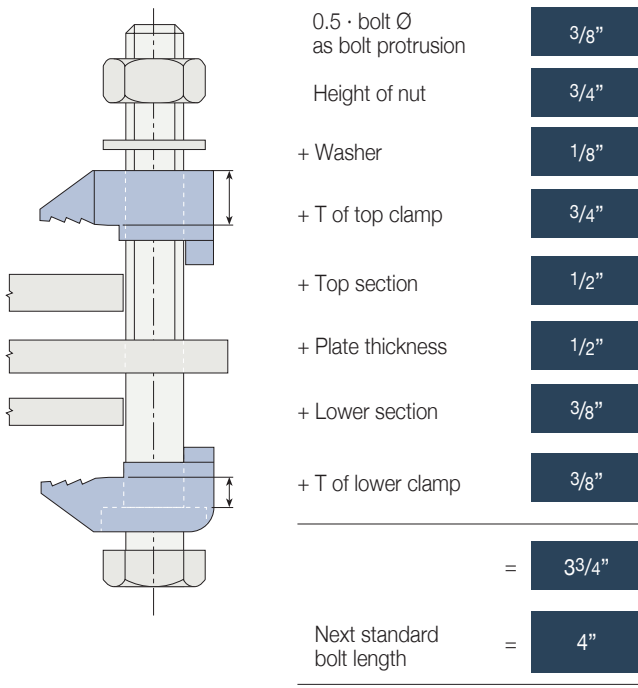

Correct installation of Types A and B

Showing Type A as an example

Parallel flanges

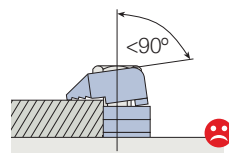
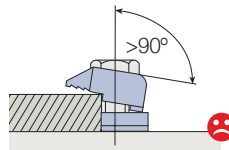
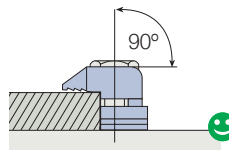

Tapered flanges

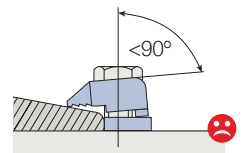
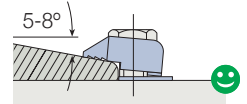
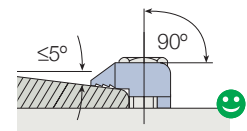

Maximum tail length tolerance (before applying tightening torque):
 Bolt sizes 3/8" to 5/8": - 3/64" tolerance
 Bolt sizes 3/4" to 1": - 1/16" tolerance

On 6° and 8° slopes, Types A and B require a special tail length / packing combination which will allow the clamp to tilt back slightly (incorporated into the combination table on page 15).

For applications above 8° please see Types AF, LR and LS.

Tail length

The different tail length can be identified by a code of dimples underneath the clamps.

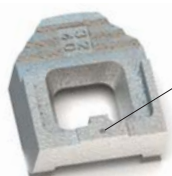

One dimple:
tail length short (s)

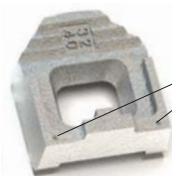

Two dimples:
tail length medium (m)

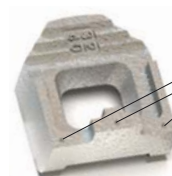

Three dimples:
tail length long (l)

Loads and Specifications

Lindapter steel connections are designed to suit the loading condition of each application, as defined below. Safe Working Loads published in this catalog are for SAE Grade 5 bolts unless otherwise stated. Should you require assistance in selecting the correct product for your needs, please contact Lindapter.

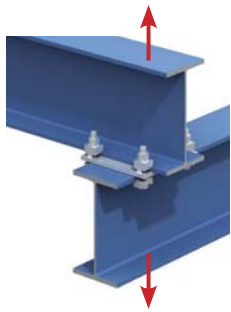

Tensile Loading

In tensile applications, the load transmits a force parallel to the center line of the bolt shank, hence applying a load to the contact point of the Lindapter. See product data tables for allowable tensile loads at varying bolt sizes.



Combined Loads

When the connections are subject to more than one load condition, the resulting forces must be calculated to determine the product and bolt sizes required. Please contact Lindapter with your application.

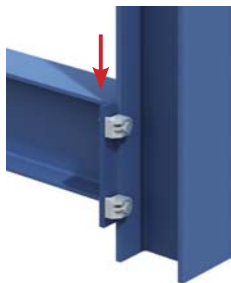

Frictional Loading

The force is applied at 90° to the bolt shank. The point at which slip occurs depends upon the condition and finish of the steel, the coating of the Lindapter and the grade of bolt used. Slip is defined as the constant load at which relative movement between clamped components exceeds 0.004 inch (0.1mm).



Compression Loading

Force here is applied directly to the supporting section rather than the Lindapter products. If, however, there is a gap between the surfaces being connected, the buckling strength of the supporting fabrication must be considered.

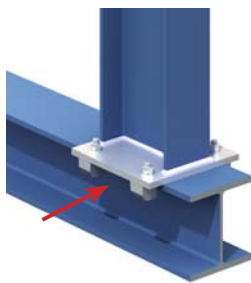

Shear Loading

The Safe Working Load of the assembly is determined by the bolt grade and diameter as the force is resisted by the cross sectional area of the bolt shanks. It is recommended that reference be made to the bolt manufacturers' technical literature or the relevant structural steel design code to ascertain a Safe Working Load per bolt.



Tightening Torque

The recommended torque values stated in the product sections must be applied in order to achieve the stated Safe Working Loads. Any reduction in torques applied will lower the product Safe Working Load and is not recommended.

Safe Working Loads

The table below shows tensile and frictional load capabilities for a standard four bolt Girder Clamp using 4 bolts and 8 clamps at a 90° crossover angle. Lindapter is only too pleased to carry out design work for individual connections free of charge based on the following details:

- Load per connection
- Size and Type of both beams
- Angle of crossover
- Distance between beams
- Inclination of beams

Clamps	Bolt size	Bolt grade	Types A, B, BR, LR				Type AF	
			1/2"	5/8"	3/4"	1"	1"	1"
			Grd. 5	Grd. 5	Grd. 5	Grd. 5	Grd. 5	A490
Safe Working Load Tensile / for 4 bolts	lbs		5205	6552	13237	17679	35968	56200 ¹⁾
Safe Working Load Friction / for 4 bolts	lbs		315	674	1349	2023	13488 ²⁾	15736 ²⁾
Tightening Torque	ft lb		50	108	210	362	590	737

1) Factor of safety 3.2:1 2) Factor of safety 2:1

➤ Loads are based on a factor of safety (typically 5:1). The reduction of published safety factors is not recommended.

Approvals

All approvals apply to Girder Clamps using Types A and B only, in sizes from 1/2" to 1". Further information is available upon request.



Type A

Malleable iron,
bright zinc plated /
hot dip galvanized

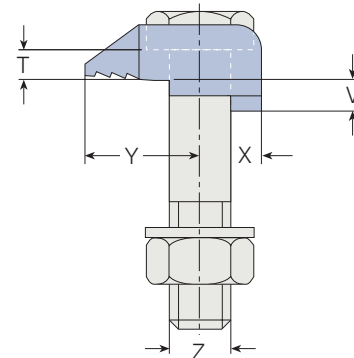
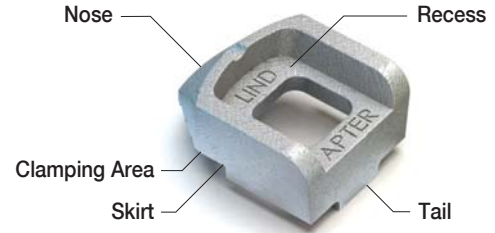
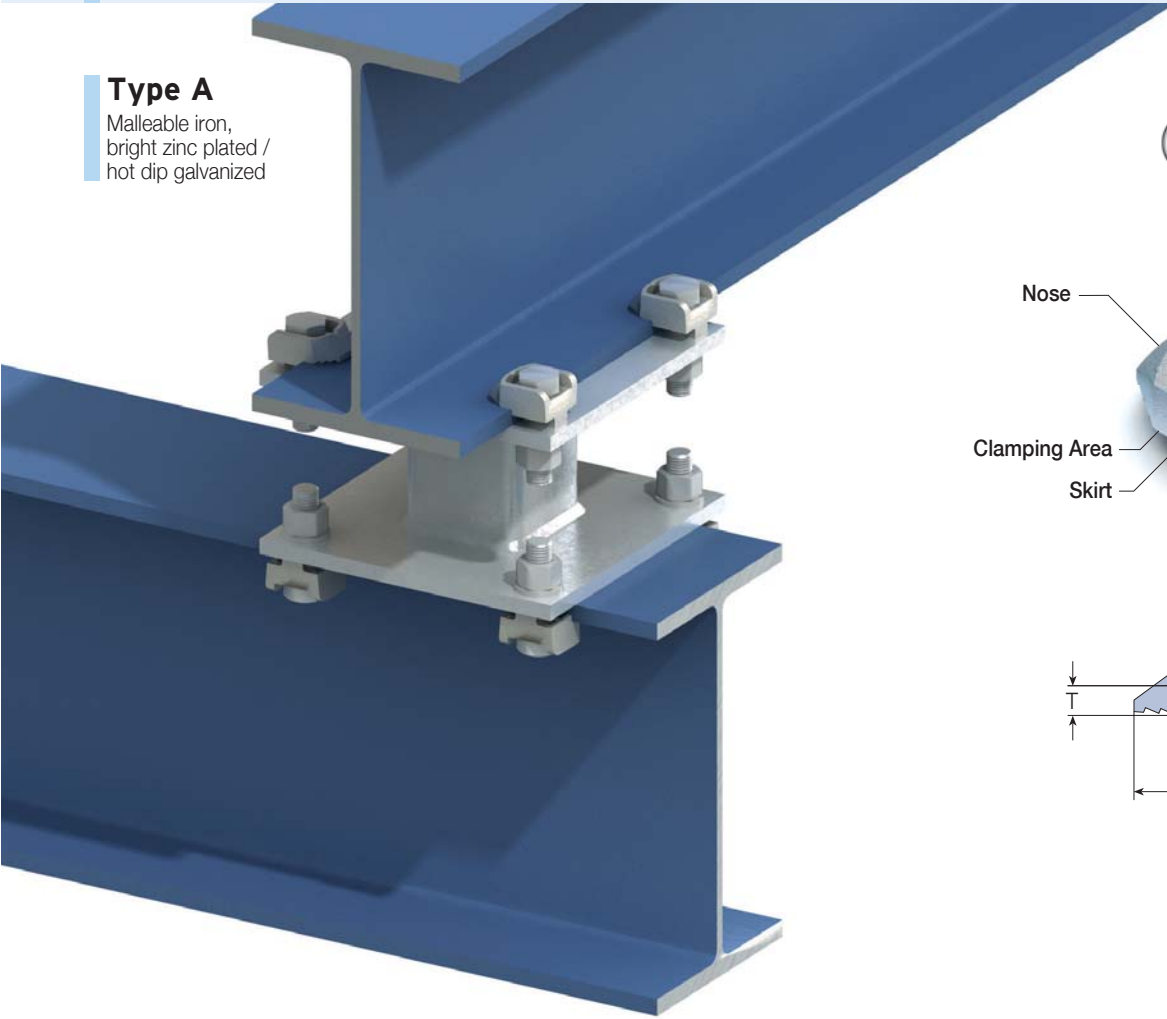

Typical Applications (see also pages 34-37)

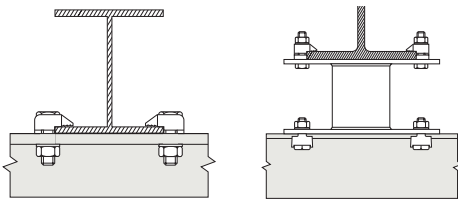

The recessed top of the Type A clamp holds the bolt head captive while the nut is tightened. The skirt prevents the clamp rotating during installation. The clamp is suitable for parallel flanges, tapered flanges up to 8° and installed correctly when the clamping area grips the flange. The tail must be chosen to suit the thickness of the flange being gripped. For correct tail length/packing combinations, please see page 15.

Product Code	Grd. 5 Bolt Size Z	Safe Working Loads (5:1 Factor of Safety)		Tightening Torque ft lb	Y	X	Dimensions Tail Length V			T	Width
		Tensile / 1 Bolt lbs	Frictional / 2 Bolts lbs				short	medium	long		
LA037 ¹⁾	3/8"	330	-	15	13/16"	7/16"	1/8"	3/16"	1/4"	3/16"	1"
LA050	1/2"	1300	157	50	1"	1/2"	3/16"	1/4"	3/8"	1/4"	1 1/8"
LA062	5/8"	1640	337	108	1 3/16"	5/8"	1/4"	5/16"	7/16"	5/16"	1 3/8"
LA075	3/4"	3300	674	210	1 7/16"	3/4"	5/16"	3/8"	1/2"	3/8"	1 13/16"
LA100	1"	4430	1012	362	1 7/8"	1"	3/8"	1/2"	5/8"	1/2"	2 1/8"

¹⁾ Requires Type W washer, product code LW037 (see Page 14).

▶ If using A325 bolts, the Type B should be used (see Page 13). ▶ For higher loads, the Type AF should be used (see page 16).

■ Order example: LA062M

Type B

Malleable iron,
bright zinc plated /
hot dip galvanized

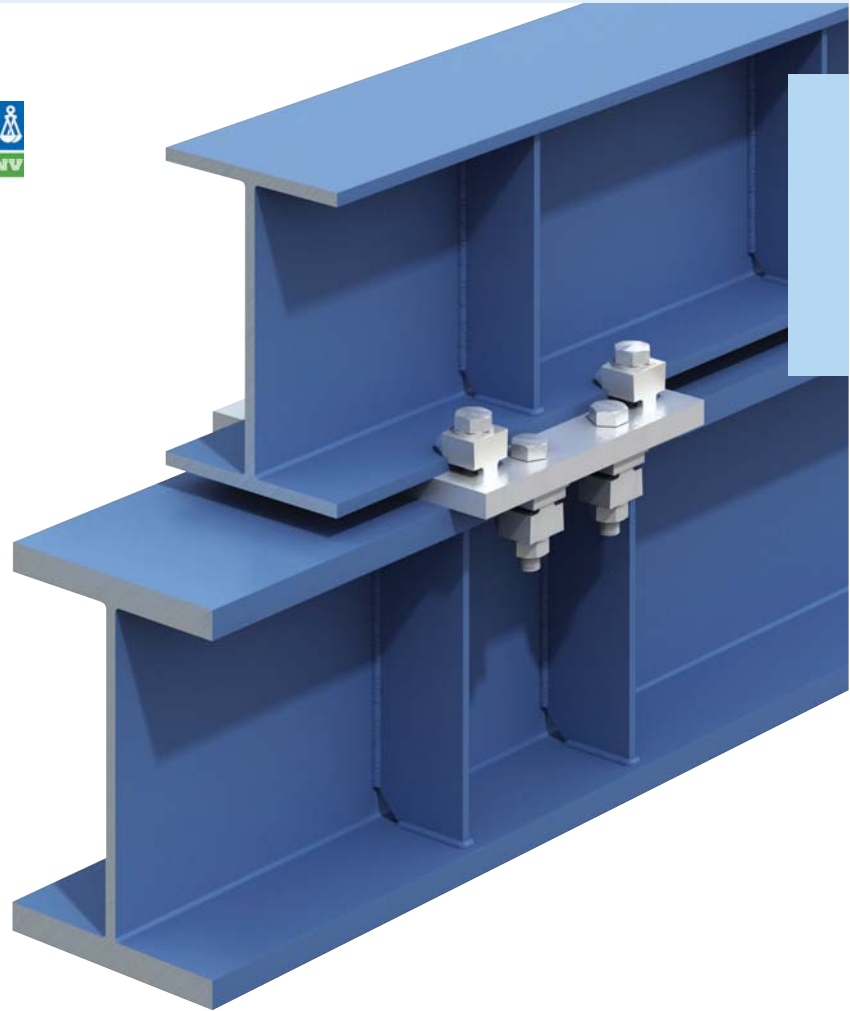
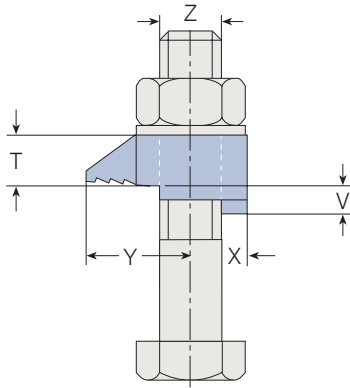
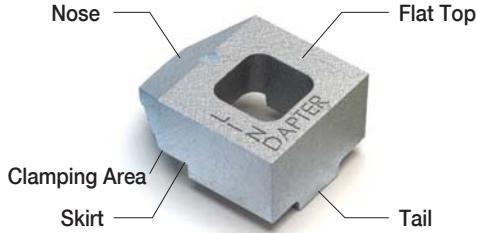

The flat top of the Type B clamp allows the bolt head or nut to be rotated. The clamp is suitable for use with bolts, studs, tie rods, J-bolts, parallel flanges and tapered flanges up to 8°. The clamp is installed correctly when the clamping area grips the flange. The tail must be chosen to suit the thickness of the flange being gripped. For correct tail length/packing combinations, please see page 15.

Typical Applications (see also page 34-37)

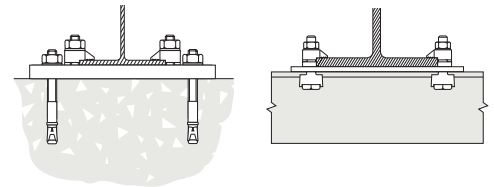

Product Code	Grd. 5 Bolt Size Z	Safe Working Loads (5:1 Factor of Safety)		Tightening Torque ft lb	Y	X	Dimensions Tail Length V			T	Width
		Tensile / 1 Bolt lbs	Frictional / 2 Bolts lbs				short	medium	long		
LB037 ¹⁾	3/8"	330	-	15	13/16"	7/16"	1/8"	3/16"	1/4"	3/8"	1"
LB050	1/2"	1300	157	50	1"	1/2"	3/16"	1/4"	3/8"	1/2"	1 1/8"
LB062	5/8"	1640	337	108	13/16"	5/8"	1/4"	5/16"	7/16"	5/8"	1 3/8"
LB075	3/4"	3300	674	210	17/16"	3/4"	5/16"	3/8"	1/2"	3/4"	1 13/16"
LB100	1"	4430	1012	362	1 7/8"	1"	3/8"	1/2"	5/8"	1"	2 1/8"

1) Requires a thick flat washer under the bolt head.

➤ For higher loads, the Type AF should be used (see page 16).

■ Order example: LB062M

Type CW - Clipped Washer

Mild Steel, bright zinc plated / hot dip galvanized

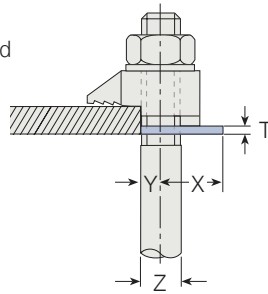

A packing used to adjust the tail length of the clamp to meet differing beam flange thicknesses.



Product Code	Bolt Size Z	Dimensions			
		Y	X	T	Width
LCW037	3/8"	3/16"	9/16"	1/16"	1"
LCW050	1/2"	1/4"	3/4"	1/8"	1 1/4"
LCW062	5/8"	5/16"	1 1/16"	1/8"	1 1/2"
LCW075	3/4"	3/8"	7/8"	3/16"	1 3/4"
LCW100	1"	1/2"	1 1/8"	3/16"	2 1/4"

Order example: LCW062

Type P1 short / P2 short

Mild Steel, malleable iron, bright zinc plated / hot dip galvanized

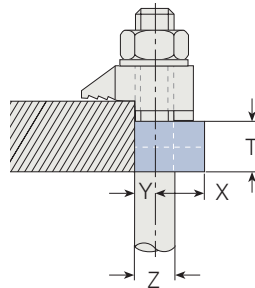

A packing used to adjust the tail length of the clamp to meet differing beam flange thicknesses.



Product Code (P1)	Product Code (P2)	Bolt Size Z	Dimensions				Width
			Y	X	T (P1)	T (P2)	
LP1037S	LP2037S	3/8"	3/16"	1/2"	3/16"	3/8"	1 5/16"
LP1050S	LP2050S	1/2"	1/4"	5/8"	1/4"	1/2"	1 3/16"
LP1062S	LP2062S	5/8"	5/16"	1 3/16"	5/16"	5/8"	1 3/8"
LP1075S	LP2075S	3/4"	3/8"	1 5/16"	3/8"	3/4"	1 11/16"
LP1100S	LP2100S	1"	1/2"	1 1/4"	1/2"	1"	2 1/8"

Order example: LP1062S

Type T

Malleable iron, bright zinc plated / hot dip galvanized

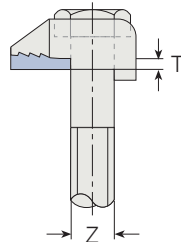

A packing, for parallel flanges only, used to fill the nose of Type A and B, making it horizontal. The thickness 'T' should be added for tail length and bolt length calculations. The product is for aesthetic purposes only and is not mandatory from a technical perspective.



Product Code	Bolt Size Z	Dimensions
		T
LT050	1/2"	1/8"
LT062	5/8"	3/16"
LT075	3/4"	3/16"
LT100	1"	1/4"

Order example: LT062

Type W

Mild Steel, malleable iron, bright zinc plated / hot dip galvanized

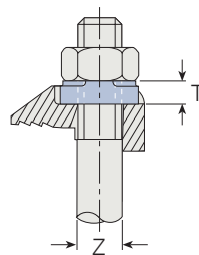
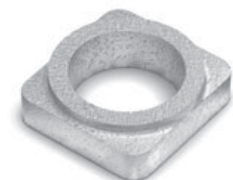

A washer used to fill the recess of Type A to enable the nut to be tightened. When calculating the bolt length, please add 'T'.

Product Code	Bolt Size Z	Dimensions
		T
LW037	3/8"	3/16"
LW050	1/2"	1/4"
LW062	5/8"	5/16"
LW075	3/4"	3/8"

Order example: LW062

Location and End Plates

- L_1 = Plate length
- L_2 = Plate width
- l_{1M}, l_{2M} = Hole centers
- b_1, b_2 = Flange width
- d = Hole \varnothing
- s = Plate thickness

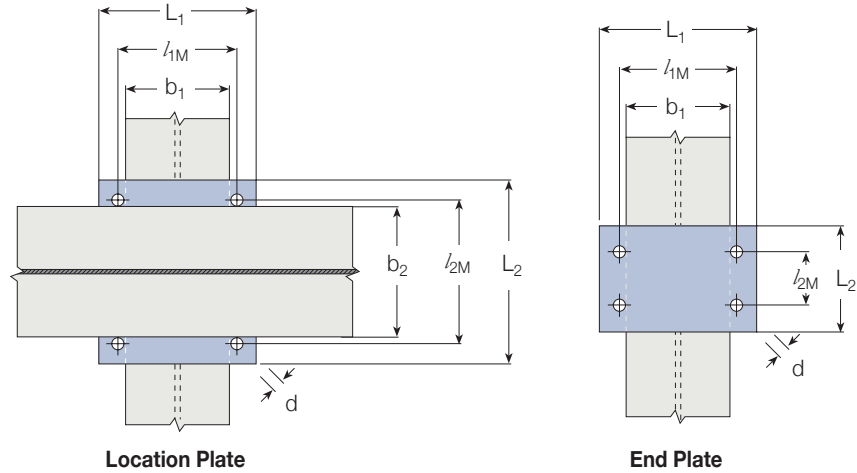

Plate Dimensions

Material: Mild Steel Grade A36 (for other grades, please contact Lindapter)

Bolt Z	Hole \varnothing d	Location Plate			End Plate ¹⁾				
		Plate Thickness s	Hole Centers l_{1M}, l_{2M}	Length/Width min $L_1, \min L_2$	Plate Thickness s	Hole Center l_{1M}	Length min L_1	Hole Center min l_{2M}	Width min L_2
3/8"	7/16"	5/16"	$b + 7/16"$	$b + 13/4"$	1/2"	$b_1 + 7/16"$	$b_1 + 13/4"$	2"	$l_{2M} + 15/8"$
1/2"	9/16"	3/8"	$b + 9/16"$	$b + 21/4"$	1/2"	$b_1 + 9/16"$	$b_1 + 21/4"$	23/8"	$l_{2M} + 2"$
5/8"	11/16"	3/8"	$b + 11/16"$	$b + 23/4"$	5/8"	$b_1 + 11/16"$	$b_1 + 23/4"$	27/8"	$l_{2M} + 23/8"$
3/4"	13/16"	1/2"	$b + 13/16"$	$b + 31/4"$	7/8"	$b_1 + 13/16"$	$b_1 + 31/4"$	35/8"	$l_{2M} + 23/4"$
1"	11/8"	5/8"	$b + 11/8"$	$b + 41/2"$	1"	$b_1 + 11/8"$	$b_1 + 41/2"$	43/8"	$l_{2M} + 35/8"$

1) Depending on type of connection and associated end plate use, the thickness may need to be modified to comply with accepted local design codes.

Calculation of bolt length see page 10

Tail Length / Packing Combinations for Types A and B

For beams up to and including 5° slope

Flange Thickness	Types A and B																			
	3/8"				1/2"				5/8"				3/4"				1"			
	A,B	CW	P1S	P2S	A,B	CW	P1S	P2S	A,B	CW	P1S	P2S	A,B	CW	P1S	P2S	A,B	CW	P1S	P2S
3/16"	m	-	-	-	s	-	-	-	■	-	-	-	■	-	-	-	■	-	-	-
1/4"	s	1	-	-	m	-	-	-	s	-	-	-	s	-	-	-	■	-	-	-
5/16"	l	-	-	-	m	1	-	-	m	-	-	-	s	-	-	-	s	-	-	-
3/8"	s	-	1	-	l	-	-	-	s	1	-	-	m	-	-	-	s	-	-	-
7/16"	l	2	-	-	m	2	-	-	l	-	-	-	s	1	-	-	m	-	-	-
1/2"	l	3	-	-	s	1	1	-	s	2	-	-	l	-	-	-	m	-	-	-
9/16"	s	-	-	1	l	2	-	-	l	1	-	-	m	1	-	-	s	1	-	-
5/8"	s	1	-	1	l	-	1	-	m	-	1	-	l	1	-	-	l	-	-	-
11/16"	l	-	-	1	m	2	1	-	l	2	-	-	s	-	1	-	s	2	-	-
3/4"	s	-	1	1	s	1	-	1	l	-	1	-	s	3	-	-	l	1	-	-
13/16"	m	-	1	1	m	1	-	1	l	3	-	-	m	-	1	-	l	1	-	-
7/8"	l	-	1	1	s	-	1	1	m	2	1	-	m	3	-	-	s	-	1	-
15/16"	s	-	-	2	m	-	1	1	m	-	-	1	m	1	1	-	m	-	1	-
1"	m	-	-	2	s	1	1	1	l	2	1	-	s	2	1	-	s	1	1	-
11/16"	l	-	-	2	m	1	1	1	l	-	-	1	s	-	-	1	l	-	1	-
11/8"	l	1	-	2	s	-	-	2	s	2	-	1	m	2	1	-	l	-	1	-
13/16"	■	-	-	-	m	-	-	2	l	1	-	1	m	-	-	1	s	2	1	-
11/4"	■	-	-	-	s	1	-	2	m	-	1	1	s	1	-	1	l	1	1	-

s = short m = medium l = long P1S = P1 short P2S = P2 short ■ = Type not applicable

➤ For thicker flanges, please contact Lindapter.

Type AF

SG iron, hot dip galvanized

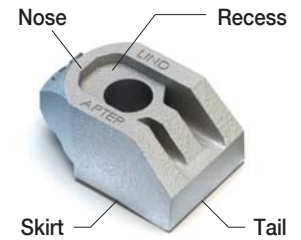
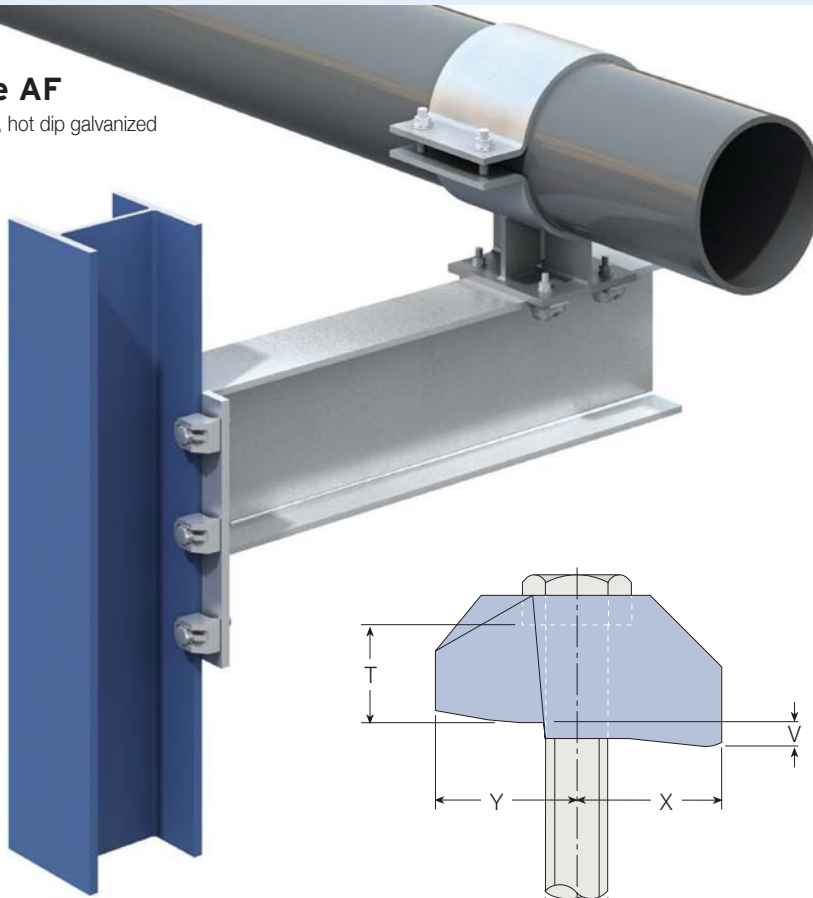

Type AF
The recess holds the bolt head captive (bolt Grade 5, sizes 1/2" to 3/4").

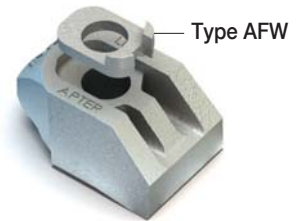

Type AF & AFW (inverted)
Holds the bolt head captive (bolt Grades A325 & A490 sizes 1/2" to 3/4").

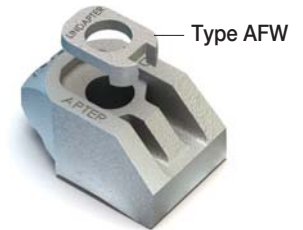

Type AF & AFW
Converts the recess to a flat top (required for 1" bolts).

Typical Applications (see also page 34-37)

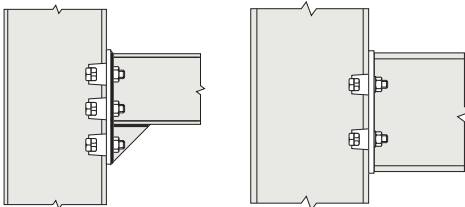

A High Slip Resistance (HSR) clamp with a recessed top to hold the bolt head captive while the nut is tightened. Washer Type AFW available (see illustrations above and page 18). The skirt prevents the clamp rotating during installation. The tail of the AF spans across slotted holes. Suitable for flanges up to 10°, ideal for S-beams. The clamp can be combined with Type CF.

For correct tail length/packing combinations, please see page 19.

The Type AF is compatible with Grade 5/A325 and A490 bolts: please refer to the table below for performance comparisons.

Product Code	Bolt Grade	Tensile / 1 Bolt lbs	Safe Working Loads (5:1 Factor of Safety (2:1))			Tightening Torque ft lb	Dimensions						
			Frictional ¹⁾ / 2 Bolts		Y		X	Tail Length V		T	Width		
			Painted Steel ²⁾	Galv. Steel				short	medium			Type AF	Type AF with AFW
LAF050	1/2"	Grd. 5/A325	1911	764	877	66	11/8"	11/16"	3/16"	1/2"	11/16"	7/8"	19/16"
LAF062	5/8"	Grd. 5/A325	3597	1798	2248	177	13/8"	11/2"	5/16"	9/16"	7/8"	11/16"	115/16"
LAF075	3/4"	Grd. 5/A325	5901	2922	3597	347	19/16"	19/16"	3/8"	11/16"	1"	11/4"	23/16"
LAF100	1"	Grd. 5/A325	8892	5395	6774	590	17/8"	23/8"	9/16"	11/8"	11/4"	15/8"	31/4"
LAF050	1/2"	A490	2248	899	1169	96	11/8"	11/16"	3/16"	1/2"	11/16"	7/8"	19/16"
LAF062	5/8"	A490	4383	2473	2698	221	13/8"	11/2"	5/16"	9/16"	7/8"	11/16"	115/16"
LAF075	3/4"	A490	6744	4496	5620	477	19/16"	19/16"	3/8"	11/16"	1"	11/4"	23/16"
LAF100	1"	A490	14050 ³⁾	6295	7868	737	17/8"	23/8"	9/16"	11/8"	11/4"	15/8"	31/4"

1) Frictional load figures are based on Type AF and Location plates in hot dip galvanized finish calculated against slip (movement exceeding 0.004"/0.1mm)
 2) Shot blast and painted steel
 3) 3.2:1 factor of safety

Order example: LAF050S

Type CF

SG iron, hot dip galvanized

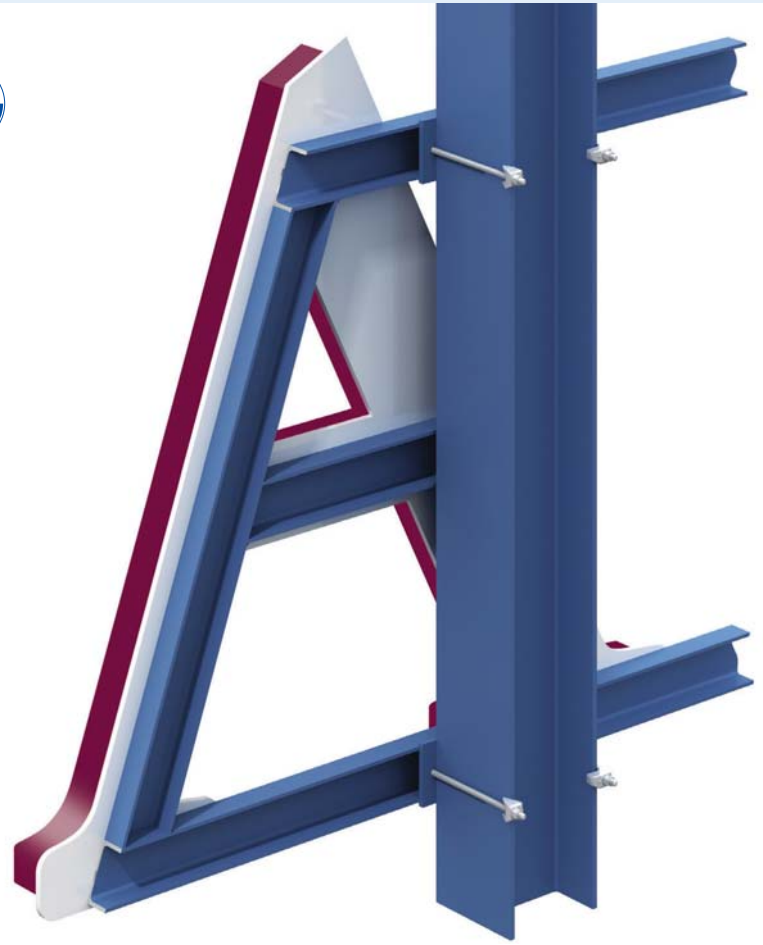
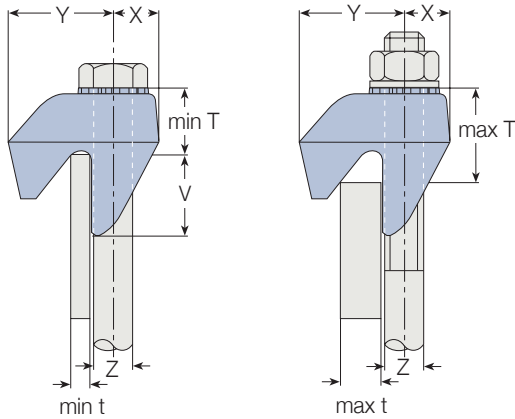
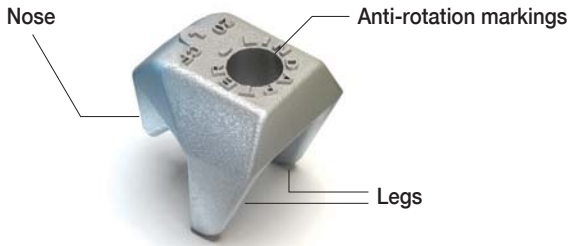

A High Slip Resistance (HSR) clamp which hooks over flanges of beams, angles and channels. Lindapter markings act as a unique anti-rotation device. Can be combined with all Lindapter Girder Clamp products, including the Type AF.

Typical Applications

(see also page 34-37)

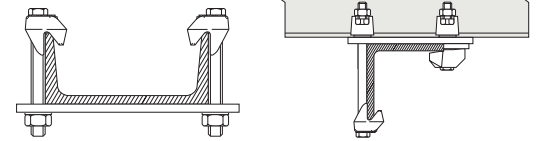

Product Code	Bolt Grd. 5 Z	Safe Working Loads				Tightening Torque ft lb	Dimensions					
		Tensile / 1 Bolt lbs	Factor of Safety		Frictional ¹⁾ / 2 Bolts lbs		Y	X	t	T	V	Width
			(5:1)	(2:1)								
LCF050	1/2"	1911		764	877	66	11/4"	9/16"	1/4" - 1/2"	13/16" - 11/8"	1"	113/16"
LCF062	5/8"	3597		1798	2248	177	13/4"	11/16"	5/16" - 5/8"	1" - 11/4"	1 1/4"	29/16"
LCF075	3/4"	5901		2922	3597	347	21/16"	7/8"	3/8" - 3/4"	13/16" - 19/16"	1 3/4"	29/16"

CF Combinations with other Lindapter Clamps

		lbs	lbs	lbs	ft lb
CF / A ³⁾	1/2"	1300	157	157	50
CF / A ³⁾	5/8"	1640	337	382	108
CF / A ³⁾	3/4"	3300	674	674	210
CF / AF	1/2"	1911	764	877	66
CF / AF	5/8"	3597	1798	2248	177
CF / AF	3/4"	5901	2922	3597	347

Order example: LCF050

1) Frictional load figures are based on Type CF and location plate in HDG finish calculated against slip (movement exceeding 0.004"/0.1mm)
 2) Shot blast and painted steel
 3) Also applies to Type B, BR, LR, D2 or D3.



Type AFCW

Mild steel, hot dip galvanized

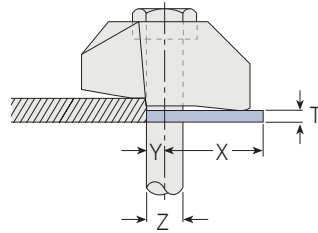

A packing used to adjust the tail length of the clamp to meet differing beam flange thicknesses; has a slight bend along its center line which flattens out during installation.



Product Code	Bolt Size Z	Dimensions			
		Y	X	T	Width
LAF050CW	1/2"	1/4"	15/16"	1/16"	19/16"
LAF062CW	5/8"	5/16"	19/16"	1/16"	2"
LAF075CW	3/4"	3/8"	15/8"	1/16"	23/16"

Order example: LAF050CW

Type AFP1 / AFP2

Mild Steel, hot dip galvanized

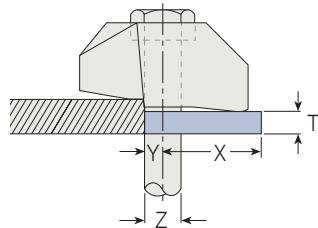

A packing used to adjust the tail length of the clamp to meet differing beam flange thicknesses.



Product Code (AFP1)	Product Code (AFP2)	Bolt Size Z	Y	X	Dimensions (AFP1) (AFP2)		Width
					T	T	
LAF050P1	LAF050P2	1/2"	1/4"	15/16"	3/16"	3/8"	19/16"
LAF062P1	LAF062P2	5/8"	5/16"	15/8"	3/16"	3/8"	21/16"
LAF075P1	LAF075P2	3/4"	3/8"	113/16"	3/16"	3/8"	23/16"
LAF100P1	LAF100P2	1"	1/2"	27/8"	3/16"	3/8"	33/8"

Order example: LAF050P1

Type AFW

SG iron, malleable iron, mild steel, hot dip galvanized

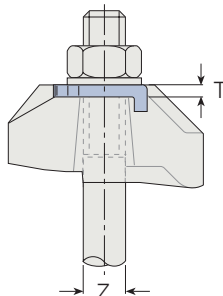

A washer used to fill the recess of the Type AF.

The washer features two projections which, when the AFW is inverted, will captivate the larger hexagons of A325 or A490 bolts (1/2" to 3/4"). LAF100W (1" version) has no projections.

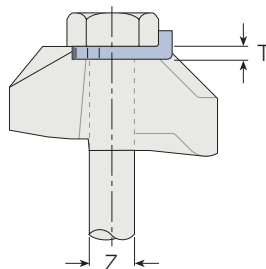

Product Code	Bolt Size Z	Dimensions
		T
LAF050W	1/2"	3/16"
LAF062W	5/8"	3/16"
LAF075W	3/4"	1/4"
LAF100W	1"	3/8"

Order example: LAF050W

Location and End Plates

- L₁** = Plate length
- L₂** = Plate width
- l_{1M}, l_{2M}** = Hole centers
- b₁, b₂** = Flange width
- d** = Hole Ø
- s** = Plate thickness

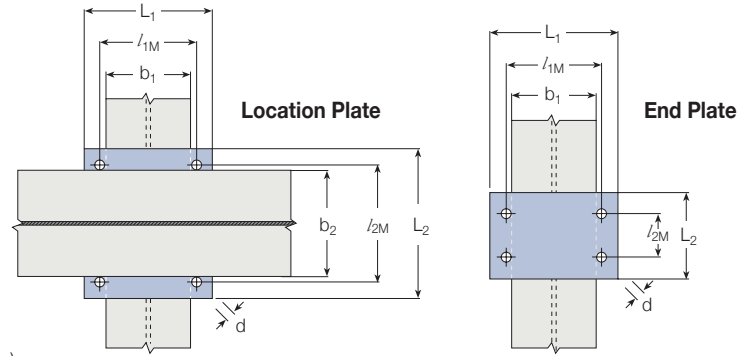

Plate Dimensions

Material: Mild Steel Grade A50 (for other grades, please contact Lindapter)

		Location Plate			End Plate ¹⁾				
Bolt Z	Hole Ø d	Plate Thickness s	Hole Centers l _{1M} , l _{2M}	Length/Width min L ₁ , min L ₂	Plate Thickness s	Hole Center l _{1M}	Length min L ₁	Hole Center min l _{2M}	Width min L ₂
1/2"	9/16"	1/2"	b + 9/16"	b + 4"	5/8"	b ₁ + 9/16"	b + 4"	31/8"	l _{2M} + 31/8"
5/8"	11/16"	5/8"	b + 11/16"	b + 4"	1"	b ₁ + 11/16"	b ₁ + 4"	4"	l _{2M} + 4"
3/4"	13/16"	3/4"	b + 13/16"	b + 5"	1-1/4"	b ₁ + 13/16"	b ₁ + 5"	7"	l _{2M} + 7"
1"	11/8"	1"	b + 11/8"	b + 7"	1-5/8"	b ₁ + 11/8"	b ₁ + 7"	77/8"	l _{2M} + 77/8"

1) Depending on type of connection and associated end plate use, the thickness may need to be modified to comply with accepted local design codes.

➤ The Type CF can be used in combination with the Type AF (see plate dimensions above), Types A, B, and BR (see page 15 for plate dimensions) and Types D2, D3 and LR (see page 23 for plate dimensions).

■ Calculation of bolt length see page 10

Tail Length / Packing Combinations for Type AF

For beams up to and including 5° slope

Flange Thickness	Type AF															
	1/2"				5/8"				3/4"				1"			
	AF	AFCW	AFP1	AFP2	AF	AFCW	AFP1	AFP2	AF	AFCW	AFP1	AFP2	AF	AFCW	AFP1	AFP2
3/16"	s	-	-	-	■	-	-	-	■	-	-	-	■	-	-	-
1/4"	s	-	-	-	■	-	-	-	■	-	-	-	■	-	-	-
5/16"	s	1	-	-	s	-	-	-	■	-	-	-	■	-	-	-
3/8"	s	-	1	-	s	1	-	-	s	-	-	-	■	-	-	-
7/16"	s	-	1	-	s	1	-	-	s	-	-	-	■	-	-	-
1/2"	m	-	-	-	s	-	1	-	s	1	-	-	s	-	-	-
9/16"	m	1	-	-	m	-	-	-	s	2	-	-	s	-	-	-
5/8"	s	-	-	1	m	-	-	-	s	-	1	-	s	-	-	-
11/16"	m	-	1	-	m	1	-	-	m	-	-	-	s	-	-	-
3/4"	s	2	-	1	m	2	-	-	m	-	-	-	s	-	1	-
13/16"	s	-	1	1	m	-	1	-	s	-	-	1	s	-	1	-
7/8"	m	-	-	1	m	1	1	-	m	2	-	-	s	-	1	-
15/16"	m	1	-	1	m	2	1	-	m	-	1	-	s	-	-	1
1"	s	-	-	2	m	-	-	1	m	1	1	-	s	-	-	1
11/16"	s	1	-	2	m	1	-	1	m	2	1	-	s	-	-	1
11/8"	m	3	-	1	s	-	-	2	m	-	-	1	s	-	-	1
13/16"	s	-	1	2	m	-	1	1	m	1	-	1	m	-	-	-
11/4"	s	1	1	2	m	1	1	1	m	2	-	1	m	-	-	-
15/16"	m	-	-	2	s	-	1	2	m	-	1	1	m	-	-	-
13/8"	s	-	-	3	m	-	-	2	m	1	1	1	m	-	1	-
17/16"	m	2	-	2	m	1	-	2	m	2	1	1	m	-	1	-
11/2"	m	-	1	2	s	-	-	3	m	-	-	2	m	-	-	1
19/16"	m	1	1	2	m	-	1	2	m	1	-	2	m	-	-	1
15/8"	m	2	1	2	m	1	1	2	m	1	-	2	m	-	-	1
111/16"	m	-	-	3	s	-	1	3	m	-	1	2	m	-	1	1
13/4"	m	1	-	3	m	2	1	2	m	1	1	2	m	-	1	1
113/16"	s	3	1	3	s	4	-	3	s	3	-	3	m	-	1	1
17/8"	s	1	-	4	m	1	-	3	m	-	-	3	m	-	1	1
115/16"	m	1	1	3	m	2	-	3	s	2	1	3	m	-	-	2
2"	s	-	1	4	m	3	-	3	s	3	1	3	m	-	-	2

s = short m = medium ■ = Type not applicable

➤ For thicker flanges please contact Lindapter.

Type LR

Malleable iron, bright zinc plated / hot dip galvanized

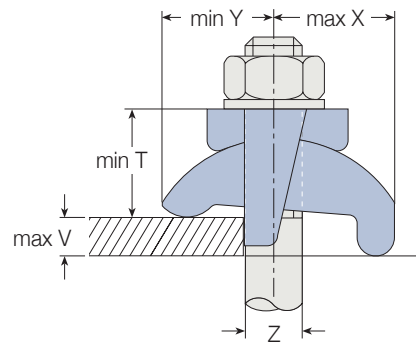
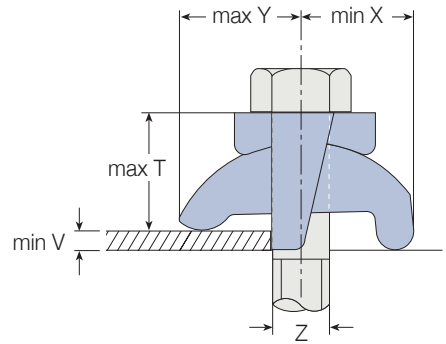
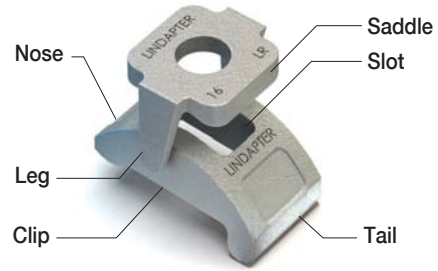

Typical Applications (see also page 34-37)

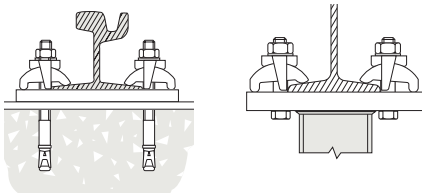

A self adjusting clamp for various flange thicknesses and slopes up to 15°. The leg of the saddle prevents the clamp from rotating during installation. The LR tail spans slotted holes. For thicker flanges, packings P1 long and P2 long are available. For correct packing combinations please see page 23.

Product Code	Grd. 5 Bolt Size Z	Safe Working Loads (5:1 Factor of Safety)		Tightening Torque ft lb	Clamping Range		Dimensions		
		Tensile / 1 Bolt lbs	Frictional / 2 Bolts lbs		V	Y	X	T	Width with Saddle
LLR037	3/8"	330	-	15	1/8" - 3/8"	13/16" - 15/16"	15/16" - 1"	13/16" - 15/16"	15/16"
LLR050	1/2"	1300	157	50	1/8" - 1/2"	1" - 1 1/8"	1" - 1 1/4"	1" - 1 1/8"	1 9/16"
LLR062	5/8"	1640	337	108	1/8" - 5/8"	1 3/16" - 1 3/8"	1 5/16" - 1 7/16"	1 3/16" - 1 7/16"	1 13/16"
LLR075	3/4"	3300	674	210	1/8" - 3/4"	1 5/8" - 1 15/16"	1 13/16" - 2"	1 5/8" - 1 7/8"	2 1/4"
LLR100	1"	4430	1012	362	1/8" - 1"	1 7/8" - 2 1/4"	2 1/16" - 2 1/4"	1 3/4" - 2 1/8"	3"

Order example: LLR037

Type D2

Malleable iron, bright zinc plated / hot dip galvanized

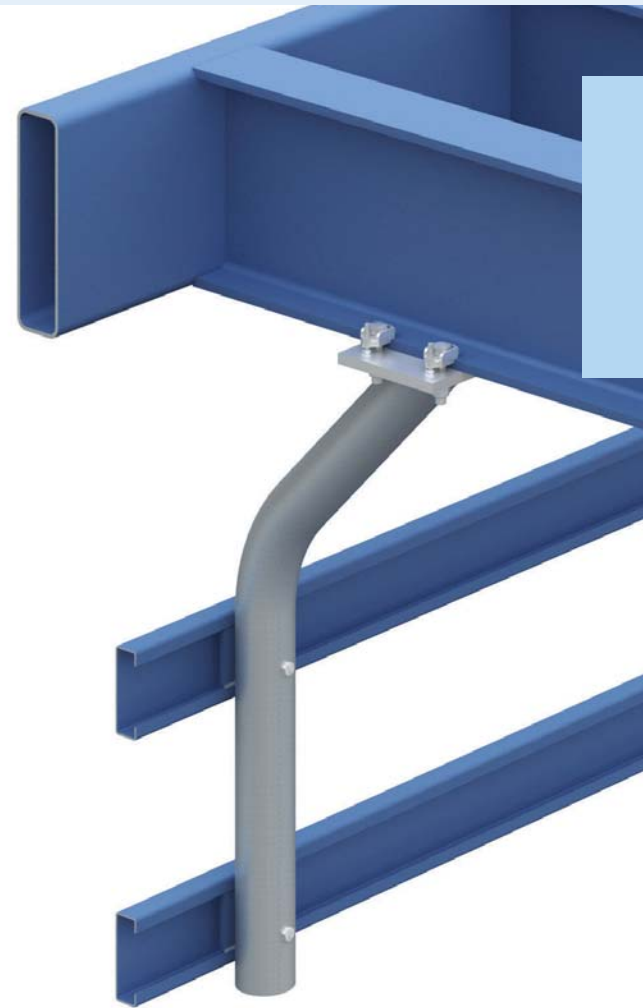
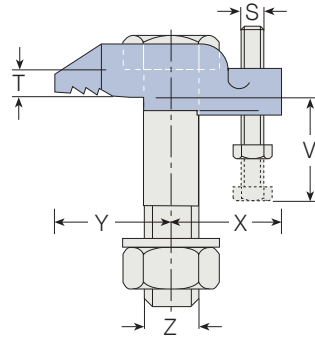
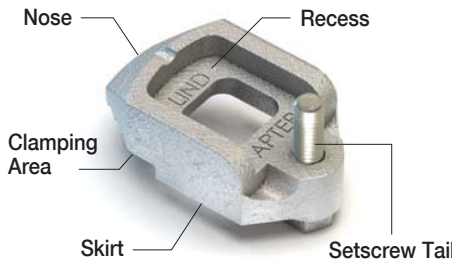

Type D3

Malleable iron, bright zinc plated / hot dip galvanized

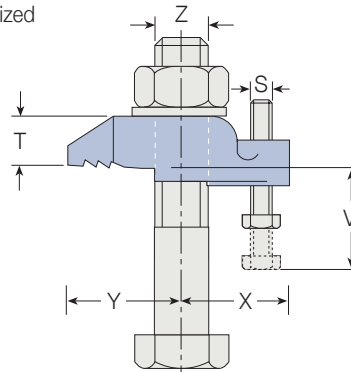

Adjustable clamps that incorporate a setscrew to accommodate a wide range of flange thicknesses. Type D2 has a recessed head to hold the bolt head captive. The skirt prevents the clamp rotating during installation. For flanges up to 5°. For thicker flanges packings P1 long and P2 long are available. For correct packing combinations please see page 23.

Correct Installation: Setscrew *S* needs to be adjusted so that *V* is 1/32" shorter than the flange thickness prior to installation. Adjust the setscrew after installation so that the bolt *Z* is 90° to the clamp and the clamp contacts the flange with the clamping area only.

Typical Applications (see also page 34-37)

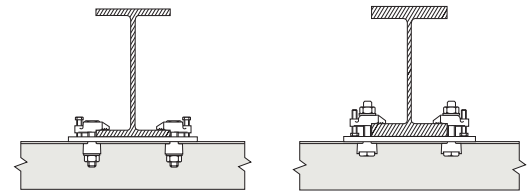

Product Code	Bolt Size Z	Safe Working Loads (5:1 Factor of Safety)		Tightening Torque ft lb	Clamping Range V ¹⁾ V ²⁾		Dimensions				
		Tensile / 1 Bolt lbs	Frictional / 2 Bolts lbs		Y	X	S	T	Width		
LD2037	3/8"	330	-	15	13/16"	3/8"	13/16"	13/16"	3/16"	3/16"	1"
LD2050	1/2"	1300	157	50	7/8"	3/8"	1"	1"	3/16"	1/4"	1 1/8"
LD2062	5/8"	1640	337	108	13/16"	1/2"	13/16"	13/16"	1/4"	5/16"	1 3/8"
LD2075	3/4"	3300	674	210	15/16"	11/16"	13/8"	13/8"	5/16"	3/8"	1 5/8"
LD2100	1"	4430	1012	362	13/16"	3/4"	17/8"	15/16"	3/8"	1/2"	2 1/8"
LD3050	1/2"	1300	157	50	7/8"	3/8"	1"	1"	3/16"	1/2"	1 1/8"
LD3062	5/8"	1640	337	108	13/16"	1/2"	13/16"	13/16"	1/4"	5/8"	1 3/8"

1) Setscrew *S* inserted from above. 2) Setscrew *S* inserted from below.

Order example: LD2100 BZP

Type P1 long / P2 long

Mild Steel, malleable iron, bright zinc plated / hot dip galvanized

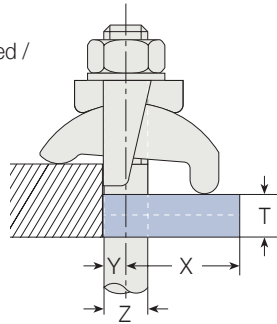

A packing used to adjust the tail length of the clamp to meet differing beam flange thicknesses.



Product Code (P1)	Product Code (P2)	Grd. 5 Bolt Size Z	Dimensions				
			Y	X	(P1) T	(P2) T	Width
LP1037L	LP2037L	3/8"	3/16"	15/16"	3/16"	3/8"	15/16"
LP1050L	LP2050L	1/2"	1/4"	1 1/4"	1/4"	1/2"	1 3/16"
LP1062L	LP2062L	5/8"	5/16"	1 9/16"	5/16"	5/8"	1 3/8"
LP1075L	LP2075L	3/4"	3/8"	1 7/8"	3/8"	3/4"	1 11/16"
LP1100L	LP2100L	1"	1/2"	2 1/2"	1/2"	1"	2 1/8"

Order example: LP1037L

Type T

Malleable iron, bright zinc plated / hot dip galvanized

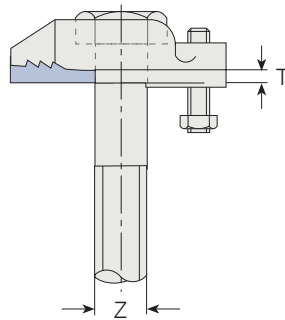

A packing to fill the nose of Type D2 and D3, making it horizontal. For parallel flanges only. The thickness 'T' should be added for tail length and bolt length calculations. The product is for aesthetic purposes only and is not mandatory from a technical perspective.



Product Code	Bolt Size Z	Dimensions
		T
LT050	1/2"	1/8"
LT062	5/8"	3/16"
LT075	3/4"	3/16"
LT100	1"	1/4"

Order example: LT062

Type W

Mild Steel, malleable iron, bright zinc plated / hot dip galvanized

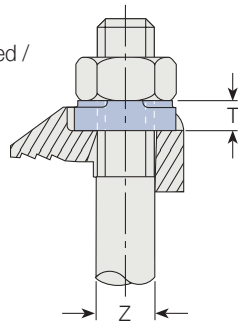
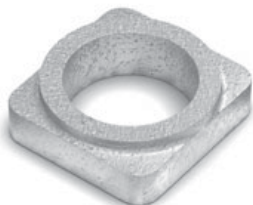

A washer used to fill the recess of Type D2 to enable the nut to be tightened. When calculating the bolt length please add 'T'.

Product Code	Bolt Size Z	Dimensions
		T
LW037	3/8"	3/16"
LW050	1/2"	1/4"
LW062	5/8"	5/16"
LW075	3/4"	3/8"

Order example: LW062

Location and End Plates

- L_1 = Plate length
- L_2 = Plate width
- l_{1M}, l_{2M} = Hole centers
- b_1, b_2 = Flange width
- d = Hole \varnothing
- s = Plate thickness

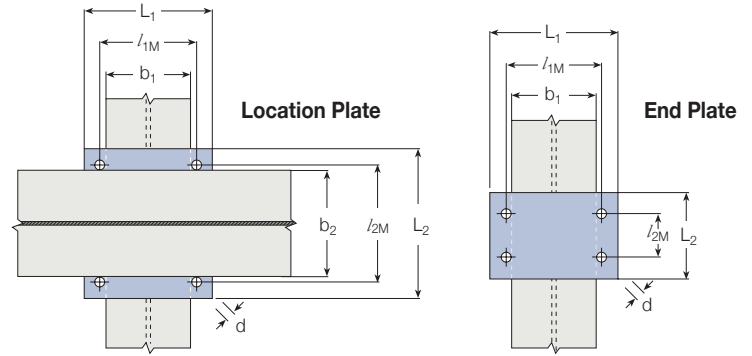

Plate Dimensions

Material: Mild Steel Grade A36 (for other grades please contact Lindapter)

Bolt Z	Hole \varnothing d	Location Plate			End Plate ¹⁾				
		Plate Thickness s	Hole Centers l_{1M}, l_{2M}	Length/Width min L_1 , min L_2	Plate Thickness s	Hole Center l_{1M}	Length min L_1	Hole Center min l_{2M}	Width min L_2
3/8"	7/16"	1/2"	$b + 7/16"$	$b + 25/8"$	5/8"	$b + 7/16"$	$b + 25/8"$	23/4"	$l_{2M} + 2"$
1/2"	9/16"	1/2"	$b + 9/16"$	$b + 33/8"$	5/8"	$b + 9/16"$	$b + 33/8"$	31/8"	$l_{2M} + 23/8"$
5/8"	11/16"	5/8"	$b + 11/16"$	$b + 41/8"$	3/4"	$b + 11/16"$	$b + 41/8"$	4"	$l_{2M} + 23/4"$
3/4"	13/16"	3/4"	$b + 13/16"$	$b + 47/8"$	1"	$b + 13/16"$	$b + 47/8"$	43/4"	$l_{2M} + 31/2"$
1"	1 1/8"	1"	$b + 11/8"$	$b + 63/4"$	1 1/4"	$b + 11/8"$	$b + 63/4"$	6"	$l_{2M} + 41/4"$

1) Depending on type of connection and associated end plate use, the thickness may need to be modified to comply with accepted local design codes.

Calculation of bolt length see page 10

Packing Combinations for Type LR

For beams up to and including 5° slope

Flange Thickness	Type LR											
	3/8"		1/2"		5/8"		3/4"		1"			
	P1L	P2L	P1L	P2L	P1L	P2L	P1L	P2L	P1L	P2L		
3/16"	-	-	-	-	-	-	-	-	-	-		
1/4"	-	-	-	-	-	-	-	-	-	-		
5/16"	-	-	-	-	-	-	-	-	-	-		
3/8"	-	-	-	-	-	-	-	-	-	-		
7/16"	1	-	-	-	-	-	-	-	-	-		
1/2"	1	-	-	-	-	-	-	-	-	-		
9/16"	1	-	1	-	-	-	-	-	-	-		
5/8"	-	1	1	-	-	-	-	-	-	-		
11/16"	-	1	1	-	1	-	-	-	-	-		
3/4"	-	1	-	1	1	-	-	-	-	-		
13/16"	1	1	-	1	1	-	1	-	-	-		
7/8"	1	1	-	1	1	-	1	-	-	-		
15/16"	1	1	-	1	1	-	1	-	-	-		
1"	1	1	1	1	-	1	1	-	-	-		
11/16"	-	2	1	1	-	1	1	-	1	-		
11/8"	-	2	1	1	-	1	1	-	1	-		
13/16"	-	2	1	1	-	1	-	1	1	-		
11/4"	1	2	-	2	-	1	-	1	1	-		

Packing Combinations for Type D2 and D3

For beams up to and including 5° slope

Flange Thickness	Types D2 and D3											
	3/8"		1/2"		5/8"		3/4"		1"			
	P1L	P2L	P1L	P2L	P1L	P2L	P1L	P2L	P1L	P2L		
7/8"	1	-	-	-	1	-	-	-	-	-		
15/16"	1	-	1	-	1	-	-	-	-	-		
1"	-	1	1	-	1	-	1	-	-	-		
11/16"	-	1	1	-	1	-	1	-	-	-		
11/8"	-	1	-	1	-	1	1	-	-	-		
13/16"	1	1	-	1	-	1	1	-	-	-		
11/4"	1	1	-	1	-	1	1	-	1	-		

P1L = P1 long P2L = P2 long

➔ For thicker flanges please contact Lindapter.

Type LS

Cast Stainless Steel Grade 316
 US Design Patent No: US D597,393 S.
 US Patent No: US8459624
 Multiple International Design Patents Pending

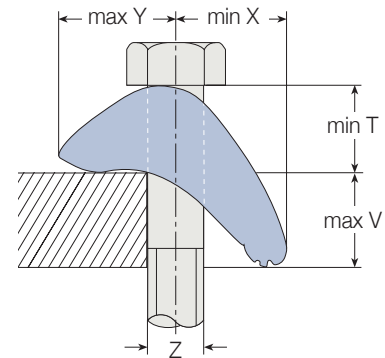
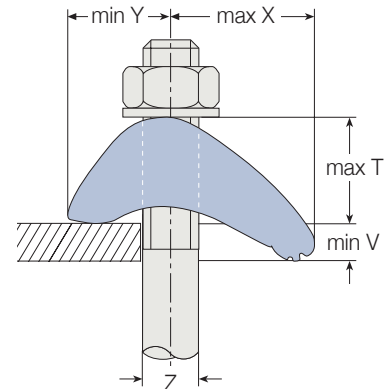
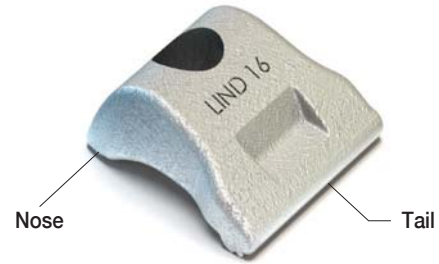
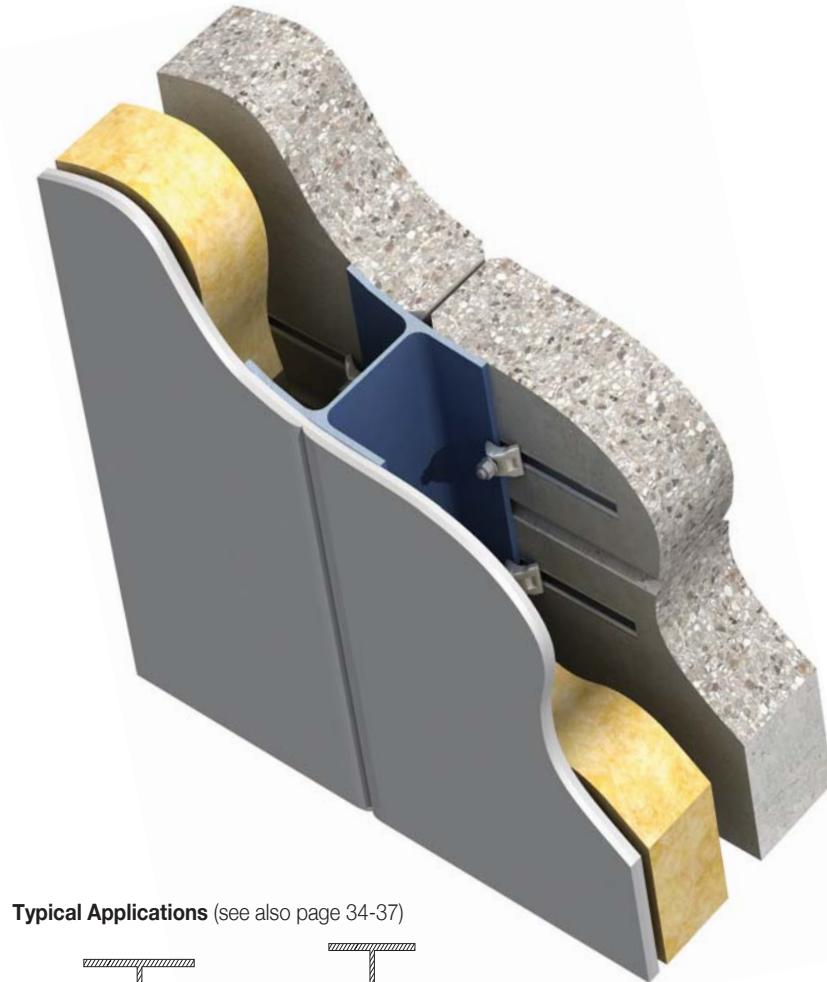

Typical Applications (see also page 34-37)

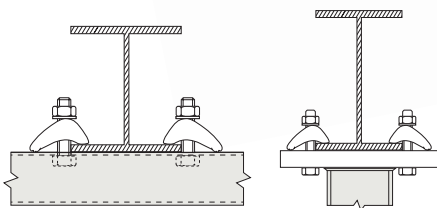

A self adjusting clamp for various flange thicknesses and slopes up to 10°. The special serrations on the tail prevent the clamp rotating during installation. The LS tail spans over slotted holes. For thicker flanges, packings LSP2 are available. For correct packing combinations please see page 25.

Product Code	Bolt A4-70 Z	Safe Working Load (5:1) Factor of Safety (2:1)		Tightening Torque ft lb	Clamping Range V	Y	Dimensions		
		Tensile / 1 Bolt lbs	Frictional ¹⁾ / 2 Bolts lbs				X	T	Width
LLS037	3/8"	675	337	30	1/8" - 9/16"	5/8" - 3/4"	11/16" - 15/16"	5/8" - 13/16"	11/2"
LLS050	1/2"	1574	450	60	1/8" - 13/16"	5/8" - 7/8"	11/16" - 11/8"	5/8" - 7/8"	19/16"
LLS062	5/8"	2248	675	148	1/8" - 1"	7/8" - 1"	11/16" - 17/16"	3/4" - 11/8"	23/16"
LLS075	3/4"	4047	1124	295	1/8" - 13/16"	15/16" - 11/4"	1" - 15/8"	7/8" - 11/4"	23/8"

1) Frictional loads calculated against slip (movement exceeding 0.004" / 0.1mm).

Order example: LLS037

Type LSP2

Stainless Steel Grade 316

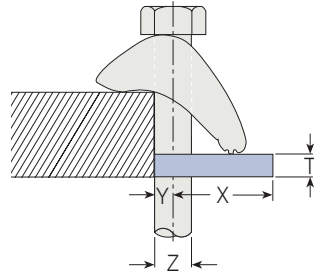

Product Code	Grd. 5 Bolt Size Z	Dimensions			
		Y	X	T	Width
LLS037P2	3/8"	3/16"	11/8"	3/8"	19/16"
LLS050P2	1/2"	1/4"	15/16"	3/8"	19/16"
LLS062P2	5/8"	5/16"	19/16"	3/8"	2"
LLS075P2	3/4"	3/8"	15/8"	3/8"	23/16"

A packing used to adjust the tail length of the clamp to meet differing beam flange thicknesses.

Order example: LLS050P2

Location and End Plates

- L_1 = Plate length
- L_2 = Plate width
- l_{1M}, l_{2M} = Hole centers
- b_1, b_2 = Flange width
- d = Hole \emptyset
- s = Plate thickness

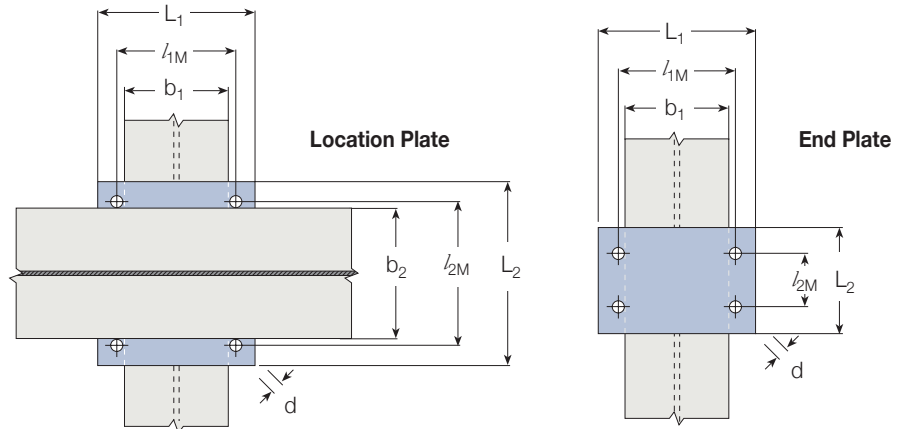

Plate Dimensions

Material: ASTM 304 or 316 Stainless Steel

Bolt Z	Hole \emptyset d	Location Plate			End Plate ¹⁾				
		Plate Thickness s	Hole Centers l_{1M}, l_{2M}	Length/Width min $L_1, \min L_2$	Plate Thickness s	Hole Center l_{1M}	Length min L_1	Hole Center min l_{2M}	Width min L_2
3/8"	7/16"	1/2"	$b + 7/16"$	$b + 23/4"$	5/8"	$b + 7/16"$	$b + 23/4"$	31/8"	$l_{2M} + 23/8"$
1/2"	9/16"	5/8"	$b + 9/16"$	$b + 31/8"$	3/4"	$b + 9/16"$	$b + 31/8"$	31/8"	$l_{2M} + 23/8"$
5/8"	11/16"	7/8"	$b + 11/16"$	$b + 4"$	1"	$b + 11/16"$	$b + 4"$	43/8"	$l_{2M} + 31/8"$
3/4"	13/16"	1"	$b + 13/16"$	$b + 51/8"$	1-1/4"	$b + 13/16"$	$b + 51/8"$	43/4"	$l_{2M} + 39/16"$

1) Depending on type of connection and associated end plate use, the thickness may need to be modified to comply with accepted local design codes.

Calculation of bolt length see page 10

Packing Combinations for Type LS

For beams up to and including 5° slope

Flange Thickness	Type LS			
	3/8"	1/2"	5/8"	3/4"
1/2"	-	-	-	-
9/16"	-	-	-	-
5/8"	1	-	-	-
11/16"	1	-	-	-
3/4"	1	-	-	-
13/16"	1	1	-	-
7/8"	1	1	-	-

Flange Thickness	Type LS			
	3/8"	1/2"	5/8"	3/4"
15/16"	1	1	-	-
1"	1	1	-	-
11/16"	2	1	1	-
11/8"	2	1	1	-
13/16"	2	1	1	-
11/4"	2	2	1	1

➔ For thicker flanges please contact Lindapter.

Type BR

Malleable iron, bright zinc plated / hot dip galvanized

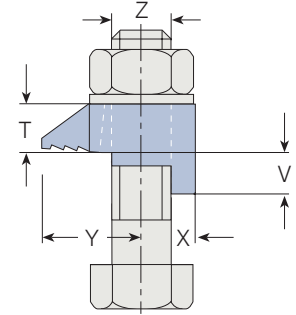
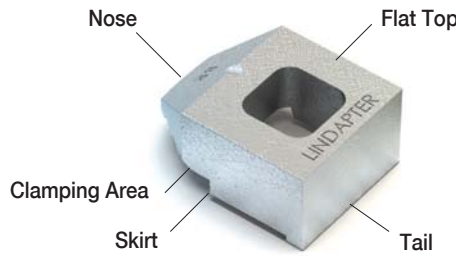

A versatile clamp for steel beams or rails. The skirt prevents the clamp from rotating during installation. The BR tail spans slotted holes. Suitable for flanges up to 8".

Product Code	Grd. 5 Bolt Size Z	Safe Working Loads (5:1 Factor of Safety)		Tightening Torque ft lb	Y	X	Dimensions			
		Tensile / 1 Bolt lbs	Frictional / 2 Bolts lbs				Tail Length V		T	Width
LBR050	1/2"	1300	157	50	1"	1/2"	3/16"	1/4"	1/2"	11/8"
LBR062	5/8"	1640	337	108	13/16"	5/8"	1/4"	5/16"	5/8"	13/8"
LBR075	3/4"	3300	674	210	13/8"	3/4"	5/16"	3/8"	3/4"	15/8"
LBR100	1"	4430	1012	362	17/8"	1"	3/8"	1/2"	1"	21/8"

Order example: LBR050S

Type RC

Forged steel, corrosion protection as required

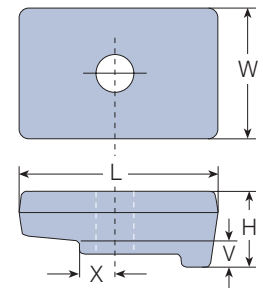
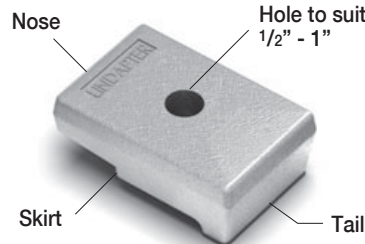

A special clamp to secure rails or steel beams of 3/8" or greater. Packings are available for thicker flanges. The RC tail spans slotted holes. Suitable for flanges up to 5". The product will be drilled to suit hole size and position requirements of the application.

Product Code	Grd. 5 Bolt Size Z	Min. Safe Working Load ¹⁾ (5:1 Factor of Safety) Tensile / 1 Bolt lbs	Tightening Torque ft lb	Tail Length V	X	Dimensions		
						L	H	Width W
RCS050	1/2"	585	50	3/8"	1/4" - 11/16"	3"	11/8"	2"
RCS062	5/8"	900	108	3/8"	3/8" - 1"	3"	11/8"	2"
RCS075	3/4"	2160	210	3/8"	7/16" - 7/8"	3"	11/8"	2"
RCS100	1"	2765	362	3/8"	1/2" - 3/4"	3"	11/8"	2"

¹⁾ The safe working load depends on the position of the bolt hole. The greater dimension X the lower the load.

Order example: RCS050 HDG with position of hole center i.e. dimension X = _____ (inch)

Type CW - Clipped Washer

Mild Steel, bright zinc plated, hot dip galvanized



A packing used to adjust the tail length of the clamp to meet differing beam flange thicknesses.

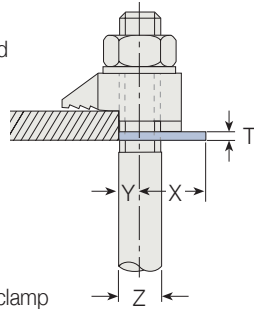

Product Code	Bolt Size Z	Dimensions			
		Y	X	T	Width
LCW050	1/2"	1/4"	3/4"	1/8"	1 1/4"
LCW062	5/8"	5/16"	11/16"	1/8"	1 1/2"
LCW075	3/4"	3/8"	7/8"	3/16"	1 3/4"
LCW100	1"	1/2"	1 1/8"	3/16"	2 1/4"

Order example: LCW050 BZP

Type P1 short / P2 short

Mild Steel, malleable iron, bright zinc plated / hot dip galvanized



A packing used to adjust the tail length of the clamp to meet differing beam flange thicknesses.

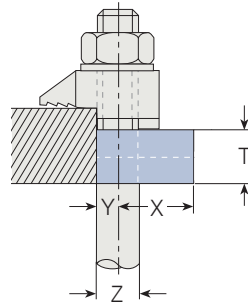

Product Code (P1)	Product Code (P2)	Bolt Size Z	Dimensions				Width
			Y	X	T (P1)	T (P2)	
LP1050S	LP2050S	1/2"	1/4"	5/8"	1/4"	1/2"	13/16"
LP1062S	LP2062S	5/8"	5/16"	13/16"	5/16"	5/8"	13/8"
LP1075S	LP2075S	3/4"	3/8"	15/16"	3/8"	3/4"	111/16"
LP1100S	LP2100S	1"	1/2"	1 1/4"	1/2"	1"	2 1/8"

Order example: LP1050S BZP

For Type BR Location and End Plates, see the 'Plate and Packing Details for Type A and B' on page 15. To calculate bolt length see page 10.

Tail Length / Packing Combinations for Types BR

For rails up to and including 8° slope

Flange Thickness	Type BR															
	1/2"				5/8"				3/4"				1"			
	BR	CW	P1S	P2S	BR	CW	P1S	P2S	BR	CW	P1S	P2S	BR	CW	P1S	P2S
3/16"	s	-	-	-	■	-	-	-	■	-	-	-	■	-	-	-
1/4"	m	-	-	-	s	-	-	-	s	-	-	-	■	-	-	-
5/16"	m	1	-	-	m	-	-	-	s	-	-	-	■	-	-	-
3/8"	s	2	-	-	s	1	-	-	m	-	-	-	s	-	-	-
7/16"	m	2	-	-	m	1	-	-	s	1	-	-	m	-	-	-
1/2"	s	1	1	-	s	2	-	-	s	1	-	-	m	-	-	-
9/16"	m	1	1	-	s	-	1	-	m	1	-	-	s	1	-	-
5/8"	s	2	1	-	m	-	1	-	s	2	-	-	m	1	-	-
11/16"	m	2	1	-	s	1	1	-	s	-	1	-	s	2	-	-
3/4"	s	1	-	1	m	1	1	-	s	3	-	-	s	2	-	-
13/16"	m	1	-	1	s	2	1	-	m	-	1	-	m	2	-	-
7/8"	s	-	1	1	m	2	1	-	m	3	-	-	s	-	1	-
15/16"	m	-	1	1	m	-	-	1	m	1	1	-	m	-	1	-
1"	s	1	1	1	s	1	-	1	s	2	1	-	s	1	1	-
11/16"	m	1	1	1	m	1	-	1	s	-	-	1	s	1	1	-
11/8"	s	-	-	2	s	2	-	1	m	2	1	-	m	1	1	-
13/16"	m	-	-	2	m	2	-	1	m	-	-	1	s	2	1	-
1 1/4"	s	1	-	2	m	-	1	1	s	1	-	1	m	2	1	-

s = short m = medium P1S = P1 short P2S = P2 short ■ = Type not applicable

➤ Type BR is only available with tail length 'short' or 'medium'.

➤ For thicker flanges please contact Lindapter.

➤ NB: The flange thickness refers to t_1 .

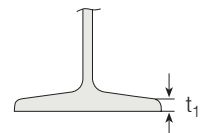

Type HD

Malleable iron, SG iron, corrosion protection as requested



Type HD Hard / Soft Clip

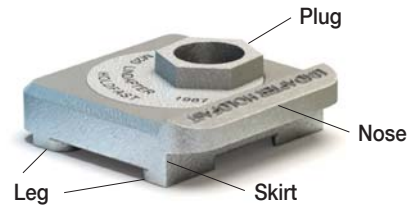

Type HD Spring Clip

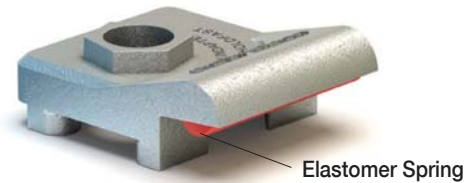

The Type HD rail clamps facilitate the precise alignment of rails by allowing a high degree of stepless lateral adjustability. Three variants are available (see opposite page).

Technical Data

Suitable for all rails with tapered flanges and crane speeds of up to 200ft/min. For wheel loads above 90,000 lbs or lateral loads higher than wheel loads please contact Lindapter.

Product Code	Clip Type	Grd. 5 Bolt Size Z	Normal		High		Leg V	Stud Length H	Dimensions		Distances		Width W
			Lateral Conditions SWL ¹⁾ lbs	Torque ft lb	Lateral Conditions SWL ¹⁾ lbs	Torque ft lb			Lateral Adjustm. max L	Plate Width min A	X ³⁾	Y ³⁾	
LHD075H	Hard	3/4"	5060	136	10340	332	F -5/16"	F +1 1/2"	±7/16"	B + 53/8"	13/16"	11/16"	215/16"
LHD075S	Soft	3/4"	5060	136	10340	332	F -3/16"	F +19/16"	±7/16"	B + 53/8"	13/16"	11/16"	215/16"
LDHD075SP	Spring	3/4"	5060	136	10340	332	F -5/16"	F +19/16"	±7/16"	B + 53/8"	13/16"	11/16"	27/8"
LHD075S-P	Soft & Pad	3/4"	5060	136	10340	332	F ¹⁾	F +1 3/4"	±7/16"	B + 53/8"	13/16"	11/16"	215/16"
LHD075SP-P	Spring & Pad	3/4"	5060	136	10340	332	F -1/16" ²⁾	F +1 3/4"	±7/16"	B + 53/8"	13/16"	11/16"	27/8"
LHD100H	Hard	1"	9000	236	13500	560	F -5/16"	F +1 5/8"	±5/16"	B + 51/8"	13/16"	11/16"	215/16"
LHD100S	Soft	1"	9000	236	13500	560	F -3/16"	F +1 11/16"	±5/16"	B + 51/8"	13/16"	11/16"	215/16"
LHD100SP	Spring	1"	9000	236	13500	560	F -3/16"	F +1 11/16"	±5/16"	B + 51/8"	13/16"	11/16"	27/8"
LHD100S-P	Soft & Pad	1"	9000	236	13500	560	F +1/16" ²⁾	F +1 7/8"	±5/16"	B + 51/8"	13/16"	11/16"	27/8"
LHD100SP-P	Spring & Pad	1"	9000	236	13500	560	F -1/16" ²⁾	F +1 7/8"	±5/16"	B + 51/8"	13/16"	11/16"	27/8"

1) Lateral Safe Working Load (4:1 Factor of Safety)

2) Based on 3/16" thick resilient pad.

3) Based on plug set at 3 o'clock position.

NB: Leg length V for use with rail sections only with tapered base. For parallel sections please refer to Lindapter.

■ Order example: LHD075H HDG for rail reference or dimensions B____ and F____ (inch)

Type HD Hard Clip

Leg length V should be selected to clamp rail down tightly and allow no vertical rail movement. Not to be used when the rail is supported by a resilient pad.

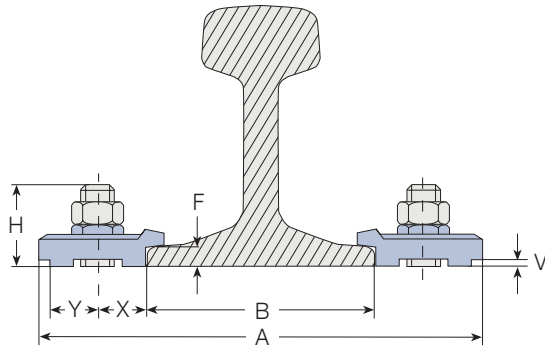

Type HD Soft Clip

Leg length V should be selected to allow vertical rail movement caused by rail wave, whilst holding the rail in precise alignment laterally. Rail ends need to be fixed.

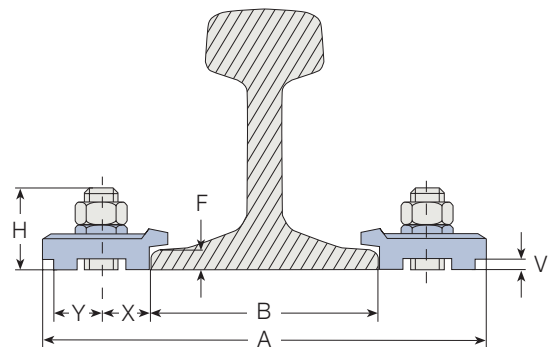

Type HD Spring Clip

The spring clip version incorporates an elastomer spring into the nose of the product, designed to provide some vertical restraint to the rail whilst still allowing the rail to lift with rail wave.

The elastomer spring is manufactured from high density synthetic polymer which has a Shore A hardness of 94.97. The spring is unaffected by salt water and most chemicals and has a high resistance to abrasion.

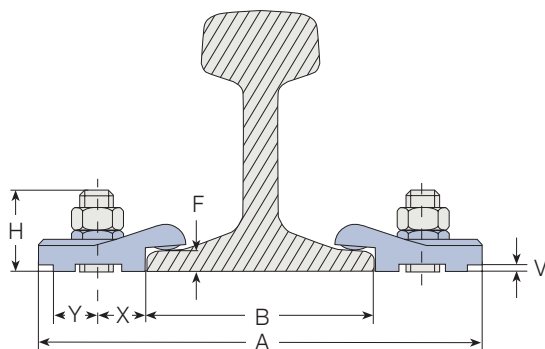

Resilient Pad

Both the spring and soft clips can be used with a resilient pad to decrease track running noise / structural vibration, level out irregular contact between surface and rail and to spread wheel load evenly over a wider area.

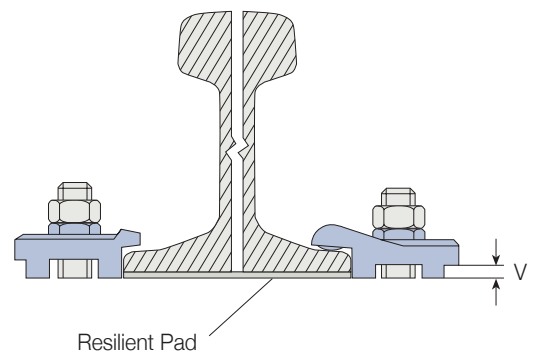

INSTALLATION

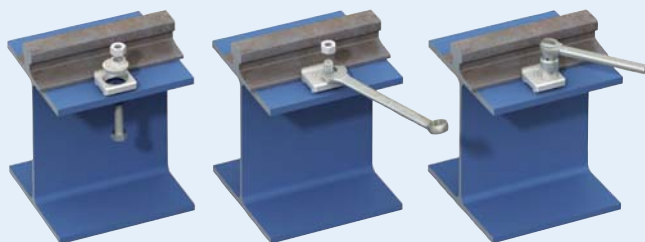

1. Position clip on bolt or stud. Place the plug in 3 o'clock position and tighten the nut.
2. Rotate the built in nut profile in a clockwise direction from the 3 o'clock position to locate the clip against the rail and laterally adjust the rail if required.

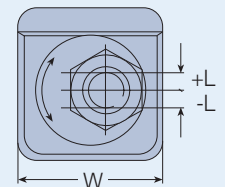

3. Apply the recommended tightening torque to the hexagon nut.

Type BSNT

Malleable iron, bright zinc plated / hot dip galvanized

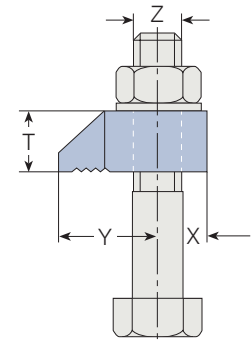
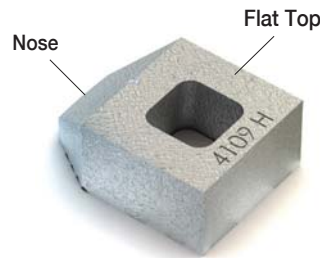

A special clamp for installation of beams flange to flange. The location plate is substituted by a connecting frame made of steel flats equalling the flange thicknesses in height. The clamps are welded to this frame.

Product Code	Grd. 5 Bolt Size Z	Safe Working Loads (5:1 Factor of Safety) Tensile / 1 Bolt lbs	Tightening Torque ft lb	Dimensions			
				Y	X	T	Width
LBSNT050	1/2"	1300	50	1"	1/2"	5/8"	11/8"
LBSNT062	5/8"	1640	108	13/16"	1/2"	3/4"	13/8"
LBSNT075	3/4"	3300	210	17/16"	3/4"	1"	15/8"
LBSNT100	1"	4430	362	17/8"	1"	1 1/4"	2 1/8"

Order example: LBSNT050

Type BSLN

Malleable iron, bright zinc plated / hot dip galvanized

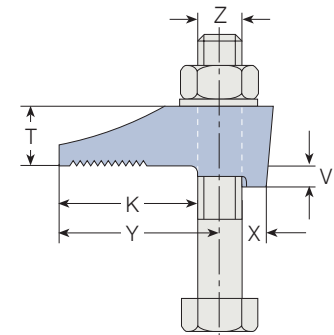
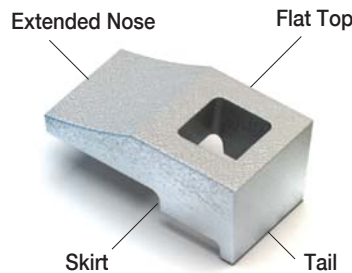

A special clamp designed with longer nose to extend the contact area with the steel section. For parallel flanges only. Can be used with Types CW, P1 short and P2 short.

Product Code	Grd. 5 Bolt Size Z	Safe Working Load (5:1 Factor of Safety) Tensile / 1 Bolt lbs	Tightening Torque ft lb	Dimensions				
				Y	X	Tail Length V	T	Width
LBSLN050	1/2"	1300	50	1 13/16"	5/8"	1/4"	11/16"	11/8"
LBSLN062	5/8"	1640	108	1 3/4"	11/16"	7/16"	5/8"	1 1/4"

Type F9

Malleable iron, bright zinc plated / hot dip galvanized

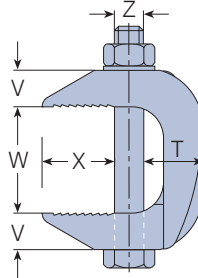
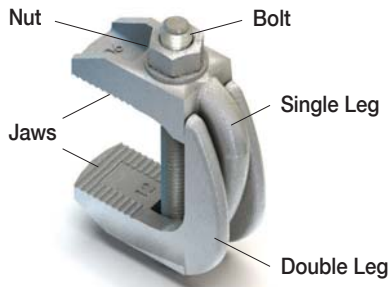

A flange clamp for connecting parallel running steel sections with flanges of the same width. The clamps can be used with bolts or alternatively with threaded rod.

➤ **Not suitable for tapered flanges.**

Product Code with Bolt	Product Code without Bolt	Bolt Size Z	Safe Working Loads (5:1 Factor of Safety) Tensile / 1 Bolt lbs	Tightening Torque ft lb	X	Dimensions		V	T	Width
						W min	W max			
LF9037WB	LF9037NB	3/8"	440	15	1"	3/4"	111/16"	1/2"	3/4"	15/16"
LF9050WB	LF9050NB	1/2"	630	29	13/8"	1"	23/8"	11/16"	15/16"	13/16"
LF9062WB	LF9062NB	5/8"	1260	69	111/16"	11/8"	23/4"	13/16"	11/8"	13/8"
LF9075WB	LF9075NB	3/4"	1880	131	2"	11/4"	31/4"	1"	13/8"	13/4"
LF9100WB	LF9100NB	1"	3147	173	3"	13/4"	33/4"	11/2"	23/16"	21/2"

Order example: LF9037WB

Type HW/HC

Malleable iron, bright zinc plated / hot dip galvanized

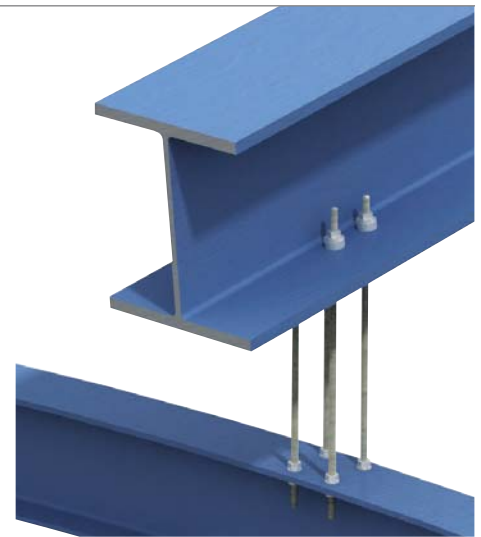
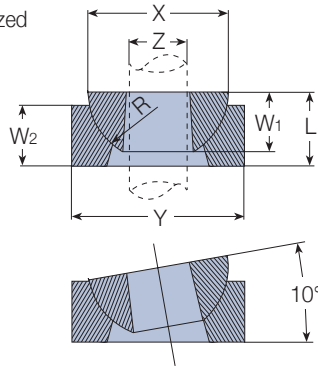
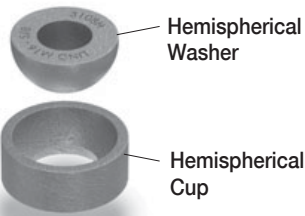

For vertical suspension on angled surface of up to 10° swing either side of the vertical. The hemispherical washer (HW) can be used without the cup. Loads are subject to applications. Please contact Lindapter for more information.

Washer	Product Code		Rod Size Z	Washer		Dimensions Cup		Washer & Cup	
	Washer	Cup		X	W ₁	Y	W ₂	R	L
LHW037	LHC037	LHC037	3/8"	1"	1/2"	11/4"	1/2"	1/2"	9/16"
LHW050	LHC050	LHC050	1/2"	11/8"	1/2"	13/8"	1/2"	9/16"	5/8"
LHW062	LHC062	LHC062	5/8"	13/8"	5/8"	15/8"	5/8"	11/16"	3/4"
LHW075	LHC075	LHC075	3/4"	13/4"	3/4"	21/8"	3/4"	7/8"	15/16"
LHW100	LHC100	LHC100	1"	21/4"	1"	25/8"	1"	11/8"	11/4"

Order example: LHW037 + LHC037

Type SC and LP

Material and corrosion protection as required

Lindapter manufactures **customized** Shackle Clamps and Lifting Points to meet individual customer requirements. Three examples of popular requests are shown below. These custom connections are designed to specific application requirements, such as vertical loads, loads at an angle and rotation of up to 360°. Please provide details of your loading, rotation, angle and beam dimensions and Lindapter's Engineers will design your connection solution.

Type SC

The Shackle Clamp is available in various configurations with vertical SWL (Safe Working Loads) **up to 13.5kip**.

Typical Configuration

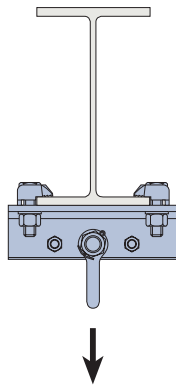

Type SC Shackle Clamp with 4 bolts

Loading: up to 13.5kip
 Directions: vertical lift
 Angle: ± 10°

Type LP

Lifting Points utilize Lindapter's high strength Type AF clamps for heavy loads, various configurations are available **up to 44kip SWL**. The product designation, i.e. LP(#) determines the number of AF clamps, for example the LP6 has 6 AF clamps to create a Safe Working Load of 22.5kip. The Type LP can be supplied with either an Eye Bolt or Load Ring. Please state your requirement when ordering.

Typical Configurations

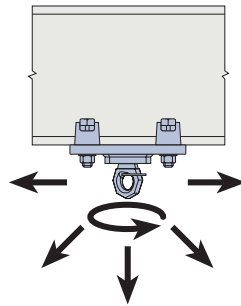
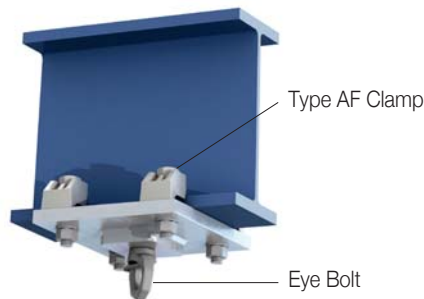

Type LP4 Lifting Point with 4 Bolts

Loading: up to 10kip
 Directions: 360° rotation
 Angle: 0 - 90°

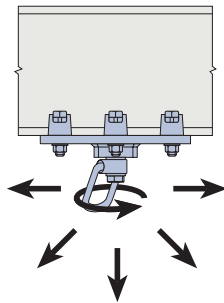
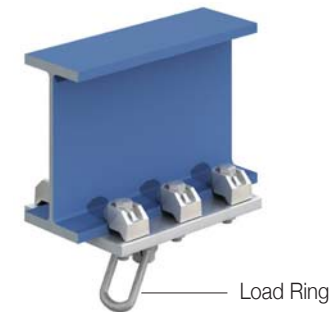

Type LP6 Lifting Point with 6 Bolts

Loading: up to 22.5kip
 Directions: 360° rotation
 Angle: 0 - 90°

Order details: Loading, rotation, angle and beam dimensions

➤ All loads are subject to suitability of supporting section. The supplied D Shackle, Eye Bolt or Load Ring may differ in appearance from the above examples, please contact Lindapter to discuss the available options.

Type FC - Flush Clamp

Forged steel, bright zinc plated plus JS500

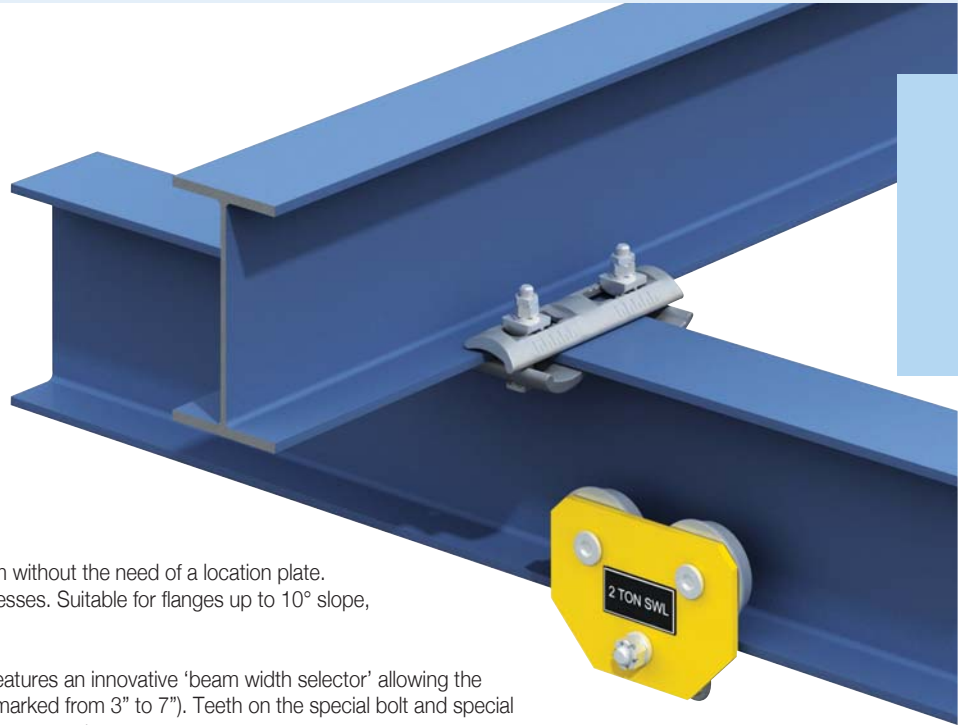

The Flush Clamp is a highly adjustable Girder Clamp System without the need of a location plate. Suitable for connecting beams of varying widths and thicknesses. Suitable for flanges up to 10° slope, ideal for S-beams.

For convenience and ease of installation, the Flush Clamp features an innovative 'beam width selector' allowing the installer to quickly adjust the clamp to the required setting (marked from 3" to 7"). Teeth on the special bolt and special washer engage teeth on the body of the clamp, preventing movement.

Product Code	Special Bolt Size Z	Safe Working Loads (5:1 Factor of Safety)		Tightening Torque ft lb	Clamping Range		Dimensions	
		Tensile / 4 Bolts lbs	Frictional / 4 Bolts lbs		Flange Thickness V	Flange Width ¹⁾ b	T	B
LFCM16	5/8"	6744	1686	108	3/16" - 3/4"	3" - 7"	7/8" - 11/16"	12"

1) Depending on beam connection angles (see table below).

Order example: LFCM16

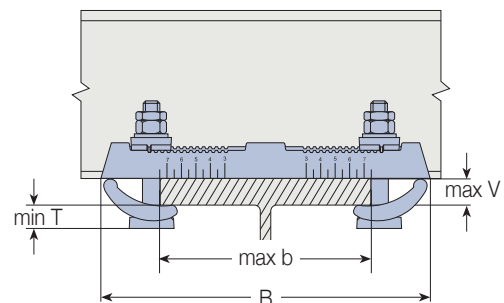
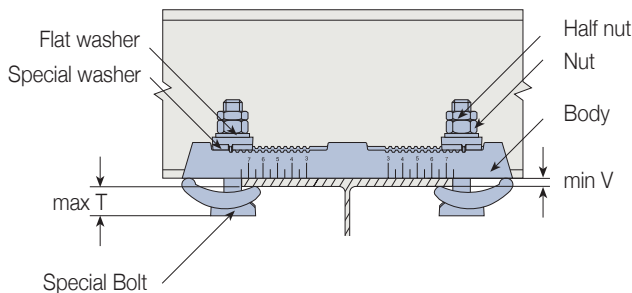

Minimum Possible Beam Connection Angles

Bottom Beam Flange Width	Top Beam				
	3"	4"	5"	6"	7"
3"	45°	50°	55°	65°	75°
4"	50°	50°	55°	65°	75°
5"	55°	55°	55°	65°	75°
6"	65°	65°	65°	65°	75°
7"	75°	75°	75°	75°	80°

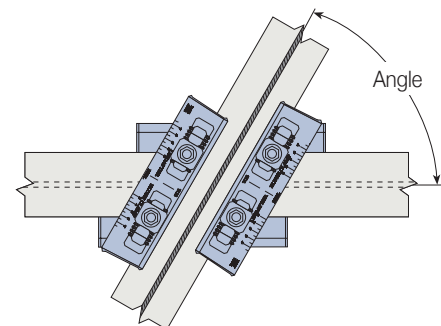

A selection of popular connection examples are shown below. Lindapter will design a custom configuration to suit your unique requirement; simply advise Lindapter of your beam dimensions and load conditions.

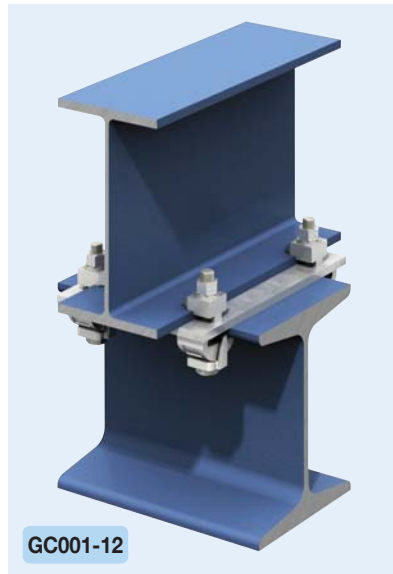
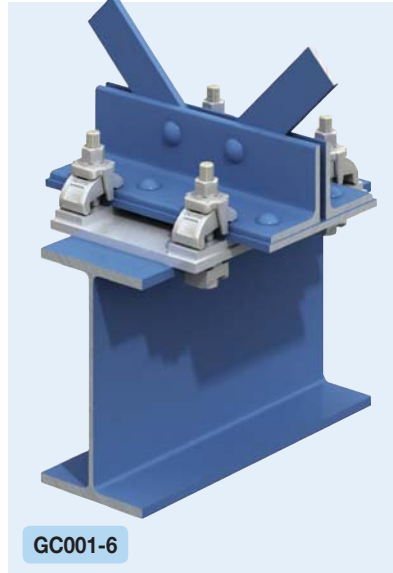
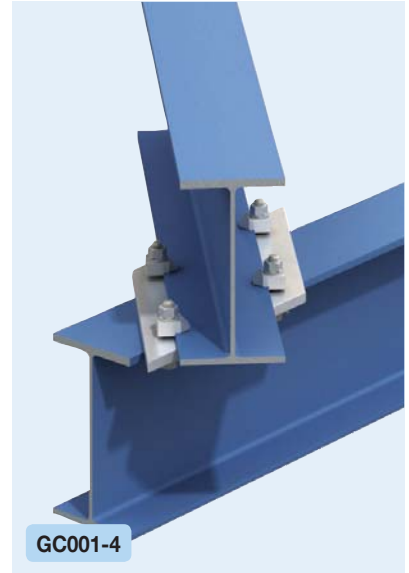
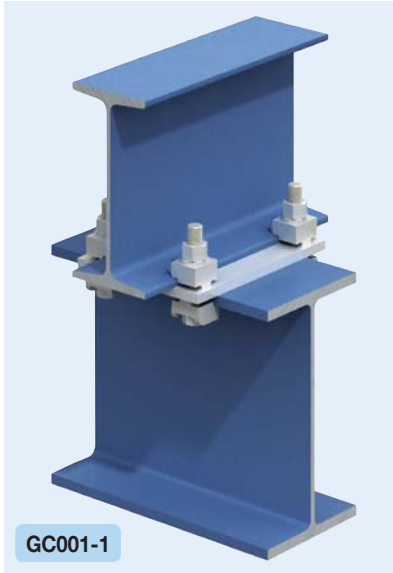

A selection of popular connection examples are shown below. Lindapter will design a custom configuration to suit your unique requirement; simply advise Lindapter of your beam dimensions and load conditions.

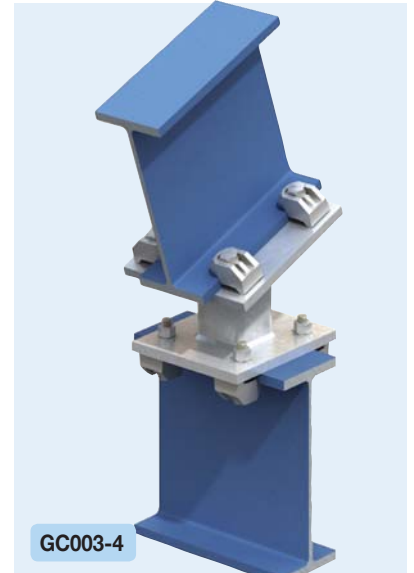
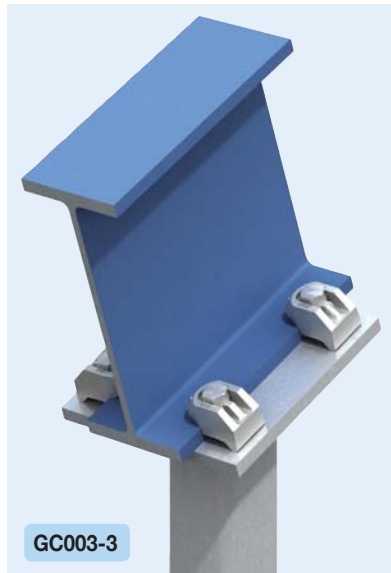
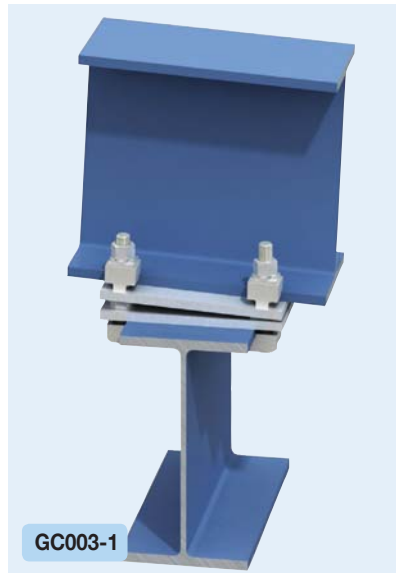
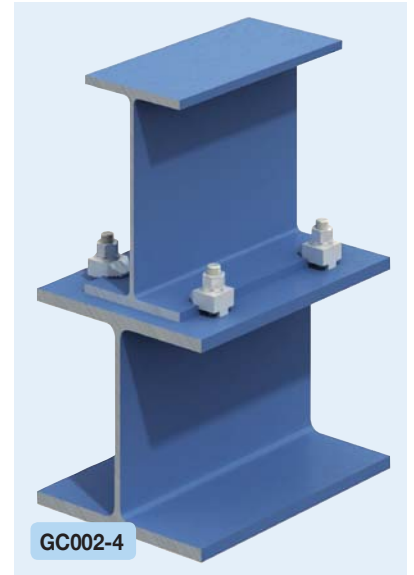
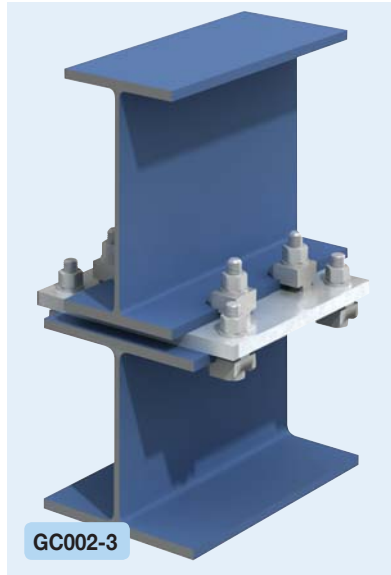
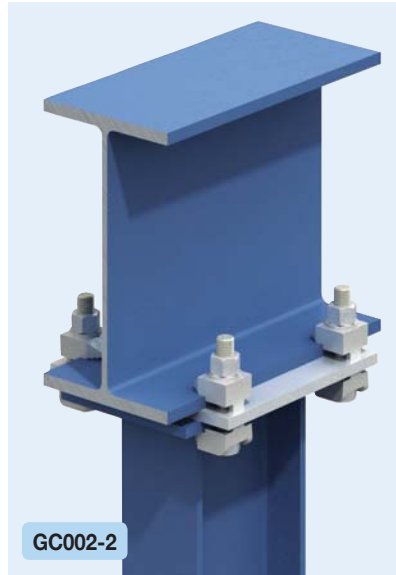

A selection of popular connection examples are shown below. Lindapter will design a custom configuration to suit your unique requirement; simply advise Lindapter of your beam dimensions and load conditions.

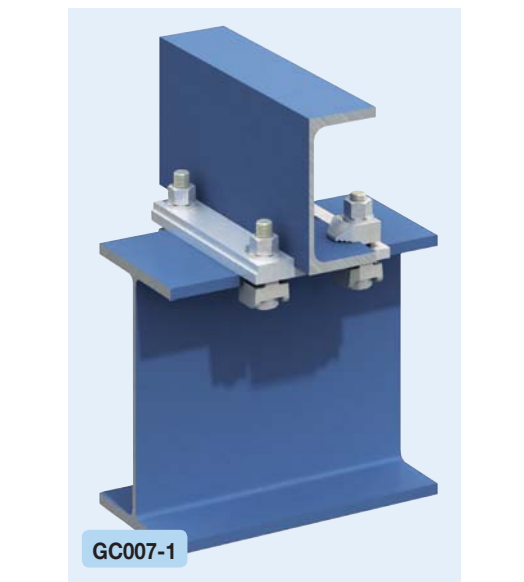
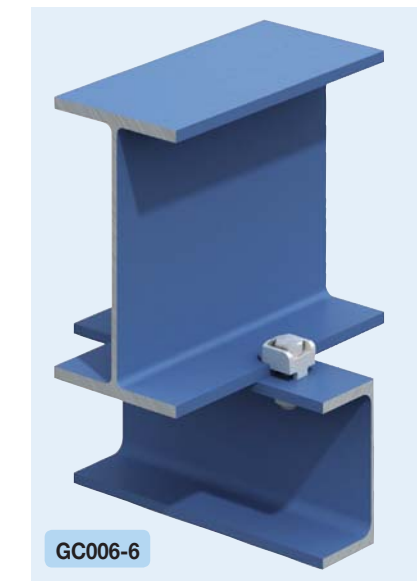
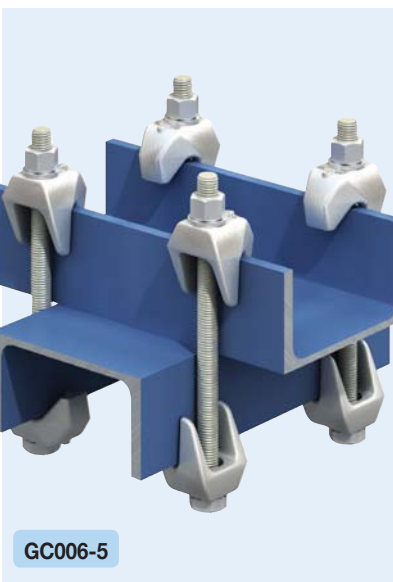
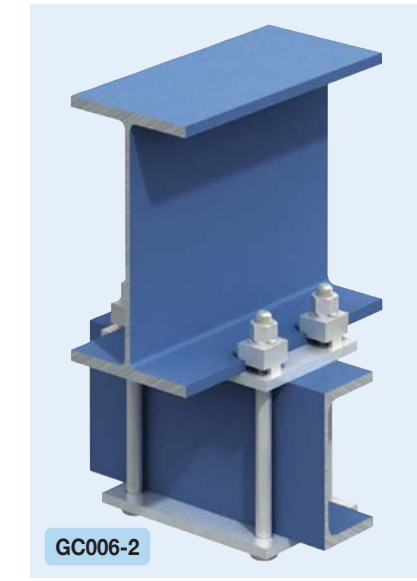
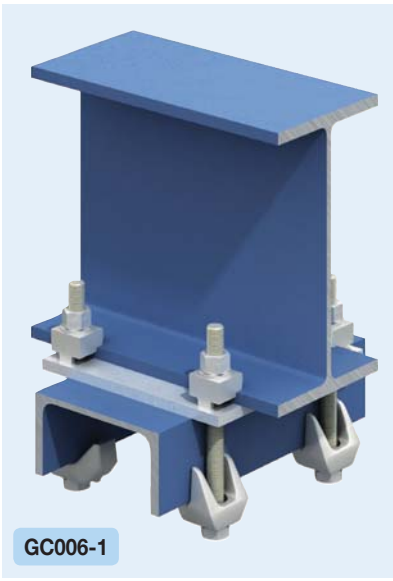
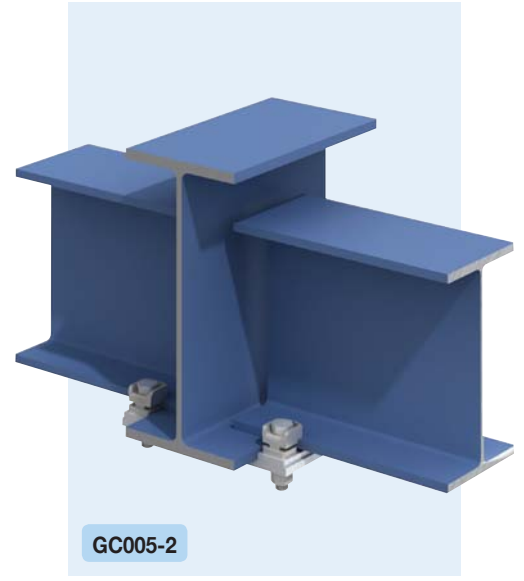

A selection of popular connection examples are shown below. Lindapter will design a custom configuration to suit your unique requirement; simply advise Lindapter of your beam dimensions and load conditions.

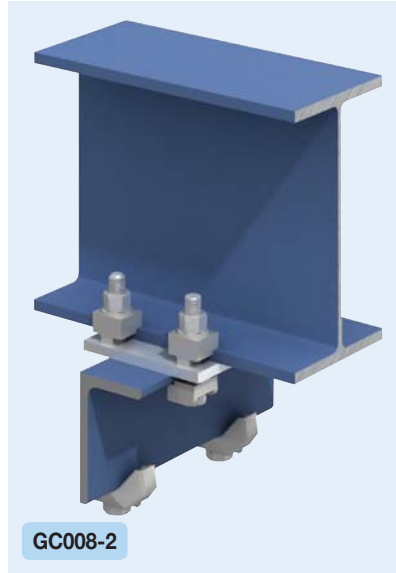

GC008-2

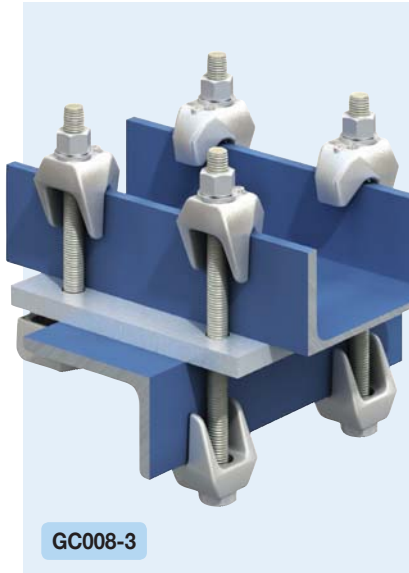

GC008-3



GC008-4

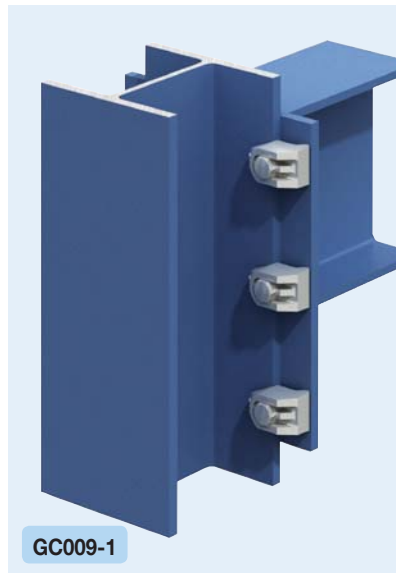

GC009-1

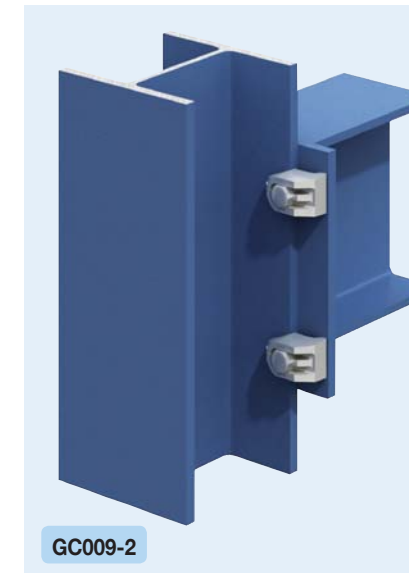

GC009-2



GC010-1



GC011-1



GC011-2

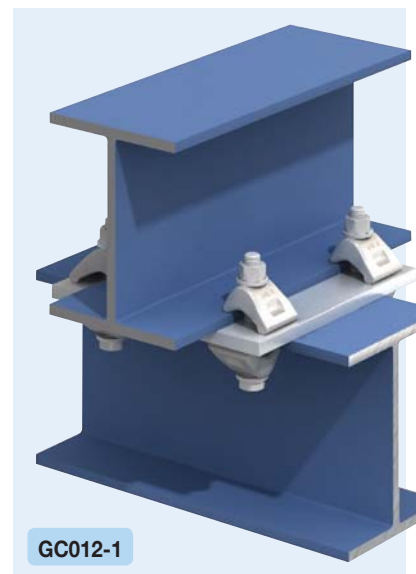

GC012-1

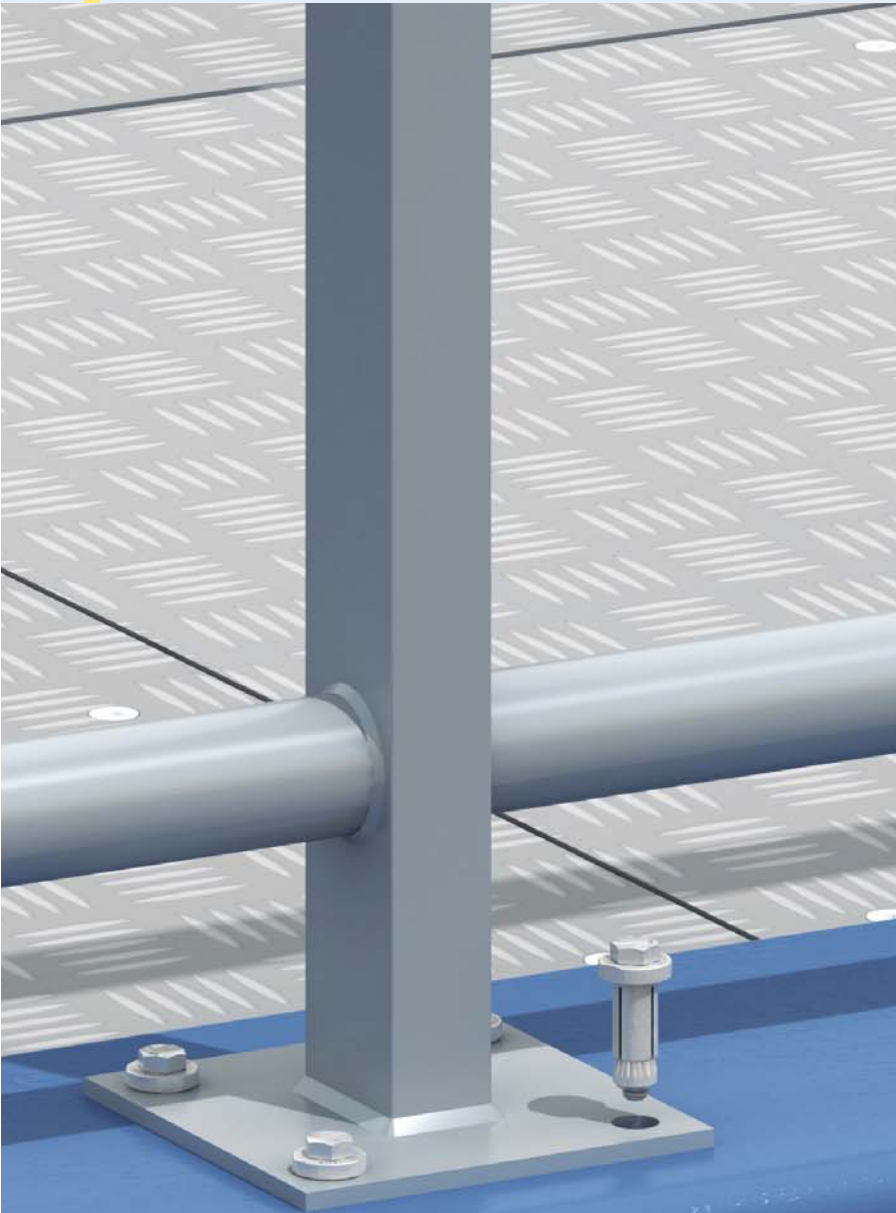

Hollow Section (HSS) Connections

The Holo-Bolt® and Lindibolt™ eliminate the need for conventional through-bolting or welding of hollow structural section (HSS) or any steel structure where access is only available from one side.

Both the Lindibolt and Holo-Bolt enable fast, safe construction and can be swiftly installed by simply inserting the product into pre-drilled holes, then tightening to the recommended tightening torque using hand tools.

In the late 1940s, Lindapter revolutionized 'blind connections' with the development of the original Lindibolt, for situations where access to both sides of the steel was restricted. Following the introduction and wide acceptance of HSS, the Holo-Bolt was invented to suit virtually any type of hollow section, including square, rectangular, circular and oval profiles. As with all Lindapter products, the R&D department has continued to develop the range with the rapid expansion in diameters, lengths, finishes and head types.

Following comprehensive testing, The Steel Construction Institute (SCI) and British Constructional Steelwork Association (BCSA) recognize the Holo-Bolt as a primary structural connection, in the design guide 'Joints in Steel Construction – Simple Connections'. The American Institute of Steel Construction (AISC) also recognizes the Holo-Bolt as a HSS connection in the Steel Construction Manual.

Typical Holo-Bolt applications include:

- Primary Connections
- Secondary Connections
- Bridges
- Cladding
- Balconies
- Towers and masts
- Staircases and handrails
- Glazing and roofs



CE Marking

In addition to Lindapter's long standing approvals, the Holo-Bolt and Lindibolt have achieved CE marking, demonstrating Lindapter's commitment to quality manufacturing and transparency of product performance.

The CE mark confirms that Lindapter initiates independent and thorough assessments of its Factory Production Control System to ensure only premium quality products leave the production line. CE marked products are subjected to a comprehensive testing programme to verify product performance to the Eurocode 3 standard, resulting in independently published European Technical Approvals (ETA).

For more information, refer to: www.lindapter.com/about/ce

Type HB - Holo-Bolt®

- Steel, bright zinc plated plus JS 500
- Steel, sheraplex
- Steel, hot dip galvanized
- Stainless Steel Grade 316

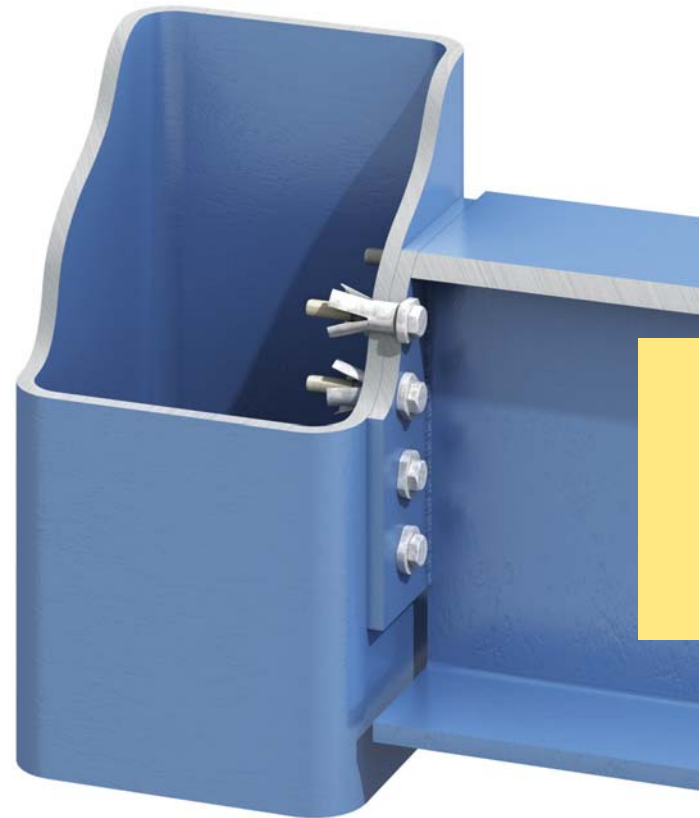

Suitable for hollow sections, tubes and where access is available from one side only. The Holo-Bolt is continuously developed to meet the requirements of Structural Engineers, with recent performance improvements including the patented High Clamping Force (HCF) version (see page 40). The Holo-Bolt is protected by multiple international patents and registered designs.

Lindapter Holo-Bolt Head Variations



Hexagonal

Visible protrusion: Regular

The Holo-Bolt collar and hexagonal head of the Grade 8.8 bolt (Grd. 5 / A325 equivalent) are evident above the surface of the steel section. This head variant is the usual choice for the majority of HSS connections, or where architects favor an 'industrial' look.



Countersunk (Bolt Head)

Visible protrusion: Minimal

This discreet midway option has a smaller protrusion for the perfect balance of appearance and convenience, and features a Grade 10.9 (A490 equivalent) countersunk bolt with a special collar designed to accommodate the entire bolt head. Drilling countersunk holes in the steel section is not required.



Flush Fit

Visible protrusion: Zero

The innovative Flush Fit Holo-Bolt is entirely concealed within a drilled countersunk hole once installed, leaving no protrusion above the surface of the steel section - the perfect solution for architects!

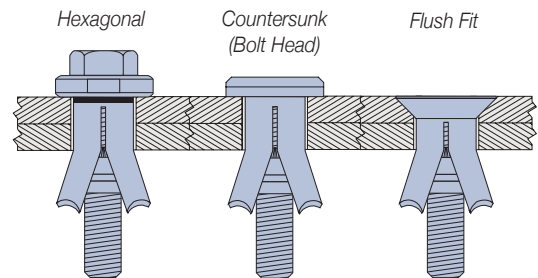

Also available: Engineered Solutions

Visible protrusion: Customized

For the rare connection requirement that an off-the-shelf Holo-Bolt cannot fulfill, Lindapter's Research & Development Facility has the capability to design and manufacture custom connection solutions. The example (left) shows the Security / Button Head. Contact Lindapter to discuss your requirement.

Availability of Head Variations

	High Clamping Force (HCF)					Bright Zinc Plated & JS500	Stainless Steel (Grade 316)	Sheraplex	Hot Dip Galvanized
	M8 (5/16")	M10 (3/8")	M12 (1/2")	M16 (5/8")	M20 (3/4")				
Hex Head	✓	✓	✓	✓	✓	✓	✓	✓	✓
Countersunk	✓	✓	✓	✓		✓	✓	✓	
Flush Fit	✓	✓	✓			✓	✓	✓	

➤ **Sizes M16 (5/8") and M20 (3/4"), known as the Holo-Bolt HCF, feature a patented High Clamping Force mechanism to produce three times more clamping force than the same sized product without the mechanism. The significance of clamping force and the superior performance of Lindapter's unique Holo-Bolt HCF is illustrated on page 40.**



Hollo-Bolt & Hollo-Bolt HCF

The Hollo-Bolt is available in two versions: the original 3-part design for general hollow section connections and the larger sized 5-part **High Clamping Force (HCF)** version, for higher strength structural connections.

Hollo-Bolt



M8 5/16"	M10 3/8"	M12 1/2"
--------------------	--------------------	--------------------

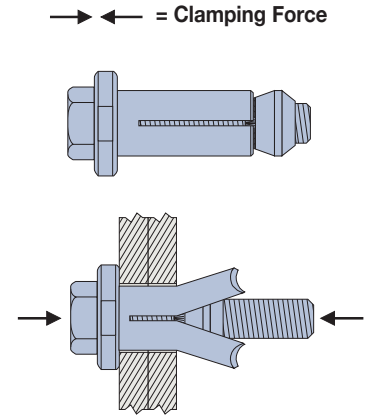

A typical connection is made by inserting the Hollo-Bolt into the pre-drilled holes of the fixture and hollow section. As the bolt head is tightened, the cone is pulled up the bolt thread, causing the legs of the sleeve to expand until the cone locks the sleeve against the inner wall of the hollow section.

At full tightening torque, a clamping action is set up between the fixture and steel section to form a secure connection.

Hollo-Bolt HCF



M16 5/8"	M20 3/4"
--------------------	--------------------

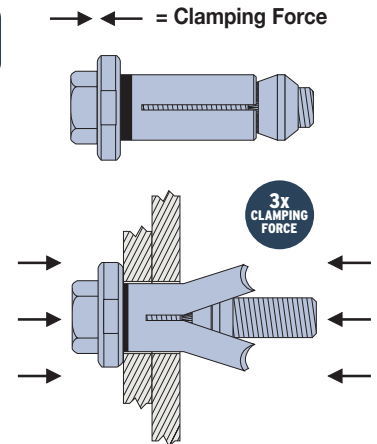

Working closely with Structural Engineers & Steel Fabricators, Lindapter identified the need for the larger M16 (5/8") & M20 (3/4") Hollo-Bolts to have an increased clamping force suitable for higher strength structural connections. Research & Development led to the invention of the patented 5-part design, optimized for superior performance.

The High Clamping Force (HCF) mechanism consists of a special washer that 'compresses' to significantly increase clamping force between the fixture and hollow section, when compared to a 3-part product of the same size, thereby reducing displacement.

Hollo-Bolt HCF
Typical Performance Increase



— With HCF Mechanism 5-Part Design (Hot Dip Galvanized, Size 2)
— Without HCF Mechanism 3-Part Design (Hot Dip Galvanized, Size 2)

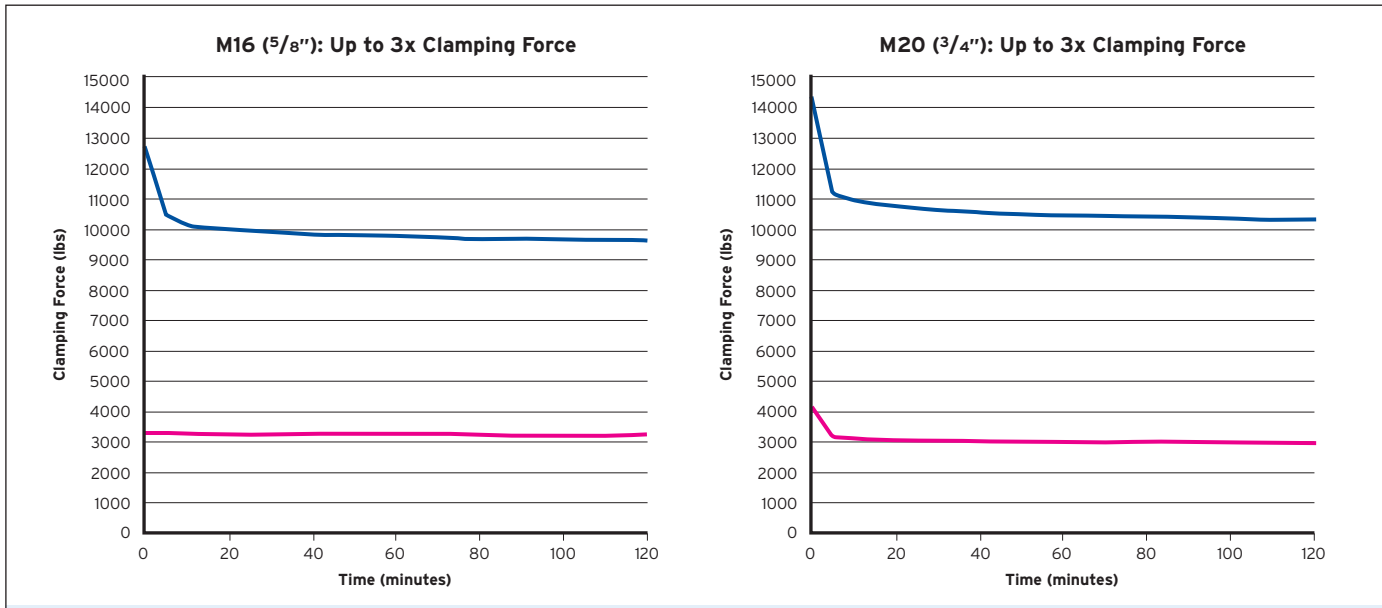

Clamping Force

As with any structural bolt, immediately after installation the bolt relaxes until a typical clamping force is reached. The typical clamping force of the Hollo-Bolt HCF is over three times higher than the same sized product without the HCF mechanism. This results in a more secure connection and a greater force that has to be overcome before displacement begins.

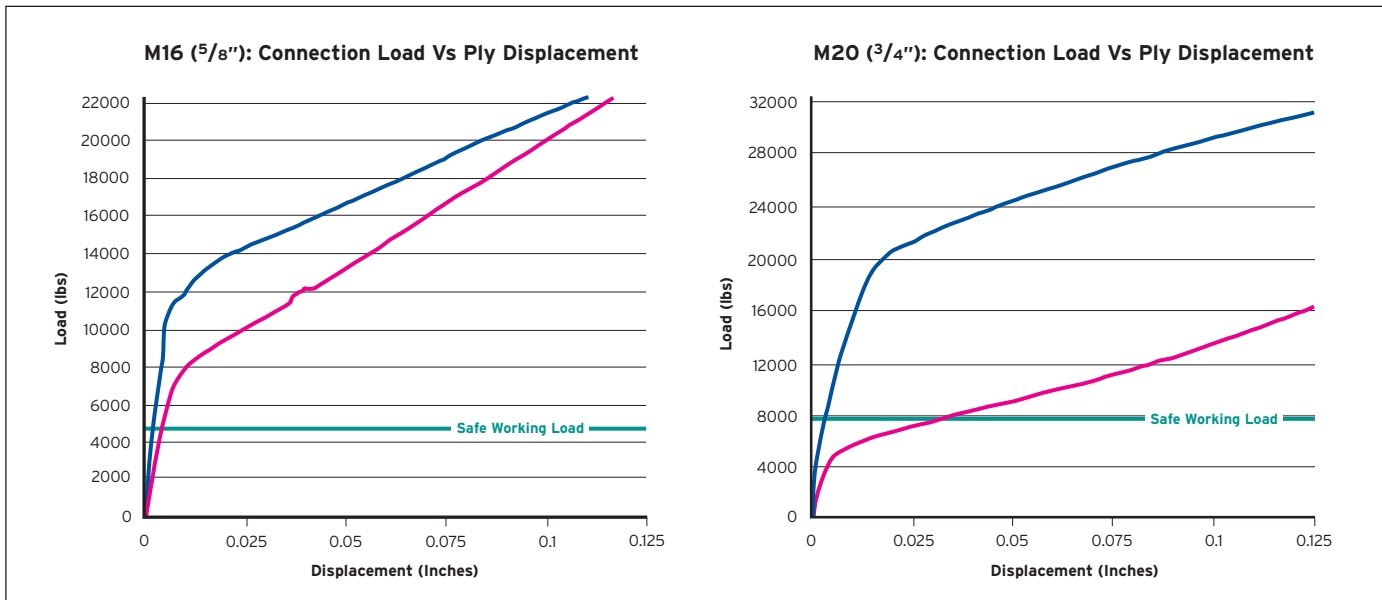

Displacement

The significance of increased clamping force is shown in the graphs above. The blue curve demonstrates the superior performance of the Hollo-Bolt HCF in contrast to M16 (5/8") & M20 (3/4") sized products without Lindapter's patented HCF mechanism (i.e. the 3-part design in these larger sizes). When using the Hollo-Bolt HCF, displacement (movement in the connection) is minimized at Safe Working Load for a safer and more secure connection.



Hollo-Bolt - Safe Working Loads

a Hexagonal

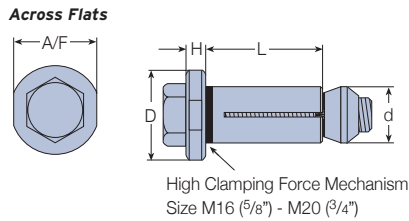

b Countersunk (Bolt Head)

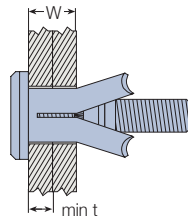

c Flush Fit

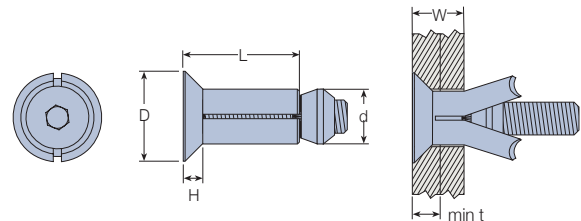

a HEXAGONAL		b COUNTERSUNK			Clamping Thickness W	Outer Ply ¹⁾ min t	Sleeve		Collar			Tightening Torque ft lb	Safe Working Loads ²⁾ (5:1 Factor of Safety)	
Product Code	Bolt	Product Code	Countersunk Bolt	Length L			Outer Ø d	Height H	D D	A/F	Tensile lbs		Single Shear lbs	
LHBM08#1	5/16" x 2"	LHBCSKM08#1	5/16" x 2"	1/8" - 7/8"	-	13/16"								
LHBM08#2	5/16" x 2 3/4"	LHBCSKM08#2	5/16" x 2 3/4"	7/8" - 1 5/8"	-	115/16"	9/16"	3/16"	7/8"	3/4"	17	899	1124	
LHBM08#3	5/16" x 3 5/8"	LHBCSKM08#3	5/16" x 3 5/8"	1 5/8" - 2 3/8"	-	211/16"								
LHBM10#1	3/8" x 2 1/4"	LHBCSKM10#1	3/8" x 2"	1/8" - 7/8"	-	13/16"								
LHBM10#2	3/8" x 3"	LHBCSKM10#2	3/8" x 3"	7/8" - 1 5/8"	-	17/8"	3/4"	1/4"	1 1/8"	1 5/16"	33	1910	2248	
LHBM10#3	3/8" x 3 5/8"	LHBCSKM10#3	3/8" x 3 5/8"	1 5/8" - 2 3/8"	-	2 5/8"								
LHBM12#1	1/2" x 2 3/8"	LHBCSKM12#1	1/2" x 2 1/4"	1/8" - 1"	-	1 3/8"								
LHBM12#2	1/2" x 3 5/8"	LHBCSKM12#2	1/2" x 3 5/8"	1" - 1 13/16"	-	2 1/4"	13/16"	1/4"	1 1/4"	1 3/16"	59	2360	3372	
LHBM12#3	1/2" x 4 1/4"	LHBCSKM12#3	1/2" x 4 1/4"	1 13/16" - 2 3/4"	-	3 1/8"								
High Clamping Force (HCF)	LHBM16#1	5/8" x 3"	LHBCSKM16#1	5/8" x 2 3/4"	1/2" - 1 1/8"	5/16"	1 5/8"							
	LHBM16#2	5/8" x 4"	LHBCSKM16#2	5/8" x 4"	1 1/8" - 2"	5/16"	2 1/2"	1 1/16"	5/16"	1 1/2"	13/8"	140	4720	6744
	LHBM16#3	5/8" x 4 3/4"	LHBCSKM16#3	5/8" x 4 3/4"	2" - 2 13/16"	5/16"	3 5/16"							
High Clamping Force (HCF)	LHBM20#1	3/4" x 3 5/8"	-	-	1/2" - 1 5/16"	5/16"	1 15/16"							
	LHBM20#2	3/4" x 4 3/4"	-	-	1 5/16" - 2 3/8"	5/16"	3"	1 5/16"	3/8"	2"	1 13/16"	221	7868	8992
	LHBM20#3	3/4" x 5 7/8"	-	-	2 3/8" - 3 3/8"	5/16"	4"							

➤ **Sizes M16 (5/8") and M20 (3/4"), known as the Hollo-Bolt HCF, feature a patented High Clamping Force mechanism to produce three times more clamping force than the same sized product without the mechanism. The significance of clamping force and the superior performance of Lindapter's unique Hollo-Bolt HCF is illustrated on page 40.**

c FLUSH FIT		Clamping Thickness W	Outer Ply min t	Sleeve		Installation Nut A/F	Tightening Torque ft lb	Safe Working Loads ²⁾ (5:1 Factor of Safety)	
Product Code	Countersunk Bolt			Length L	Outer Ø d			Tensile lbs	Single Shear lbs
LHBF08#1	5/16" x 2"	3/8" - 1 1/16"	5/16"	13/16"					
LHBF08#2	5/16" x 2 3/4"	1 1/16" - 1 3/4"	5/16"	2 1/8"	9/16"	3/4"	17	899	1124
LHBF08#3	5/16" x 3 5/8"	1 3/4" - 2 1/2"	5/16"	2 7/8"					
LHBF10#1	3/8" x 2 3/8"	1/2" - 1 1/16"	3/8"	1 3/16"					
LHBF10#2	3/8" x 3"	1 1/16" - 1 3/4"	3/8"	2 1/8"	3/4"	1 5/16"	33	1910	2248
LHBF10#3	3/8" x 3 5/8"	1 3/4" - 2 1/2"	5/16"	2 7/8"					
LHBF12#1	1/2" x 2 3/8"	1/2" - 1 3/16"	3/8"	1 3/8"					
LHBF12#2	1/2" x 3 1/8"	1 3/16" - 2 1/32"	3/8"	2 1/2"	13/16"	1 3/16"	59	2360	3372
LHBF12#3	1/2" x 4"	2 1/32" - 2 7/8"	3/8"	3 3/8"					

1) Sizes M16 (5/8") and M20 (3/4") require the thickness of the outer ply (min t) to be at least 5/16". If necessary, spacer washers should be used beneath the collar to increase the thickness to 5/16".
 2) The Hollo-Bolt can be used on a wide variety of steel hollow sections; safe working loads shown are based on use in A36 Structural Tube. The safe working loads, in both tension and shear, are applicable to the Hollo-Bolt only. Failure of the section, particularly on those with thin walls and a wide chord face, could occur at a lower figure and strength of the section should be checked by a qualified Structural Engineer.

Characteristic Values of Tensile and Shear Resistance

taken from European Technical Approval ETA-10/0416

For more information visit www.lindapter.com/about/CE



Hollo-Bolt Hexagonal

Product Code	European Code	Nominal Size	Tensile $F_{t,Rk}$ lbs	Shear $F_{v,Rk}$ lbs	Material Strength of Sleeve ksi
LHBM08	HB08	M8 ($\frac{5}{16}$ "	5193	7396	62.37
LHBM10	HB10	M10 ($\frac{3}{8}$ "	8902	12185	62.37
LHBM12	HB12	M12 ($\frac{1}{2}$ "	10296	15961	62.37
HCF LHBM16	HB16	M16 ($\frac{5}{8}$ "	18951	31248	62.37
HCF LHBM20	HB20	M20 ($\frac{3}{4}$ "	27876	47434	56.56

Hollo-Bolt Hexagonal Stainless Steel

Product Code	European Code	Nominal Size	Tensile $F_{t,Rk}$ lbs	Shear $F_{v,Rk}$ lbs	Material Strength of Sleeve ksi
LHBSTM08	HBST08	M8 ($\frac{5}{16}$ "	6025	6902	72.52
LHBSTM10	HBST10	M10 ($\frac{3}{8}$ "	10341	11465	72.52
LHBSTM12	HBST12	M12 ($\frac{1}{2}$ "	11982	14613	72.52
HCF LHBSTM16	HBST16	M16 ($\frac{5}{8}$ "	22031	28775	72.52
HCF LHBSTM20	HBST20	M20 ($\frac{3}{4}$ "	34620	46086	72.52

Hollo-Bolt Countersunk (Bolt Head)

Product Code	European Code	Nominal Size	Tensile $F_{t,Rk}$ lbs	Shear $F_{v,Rk}$ lbs	Material Strength of Sleeve ksi
LHBCSKM08	HBCSK08	M8 ($\frac{5}{16}$ "	5193	7396	62.37
LHBCSKM10	HBCSK10	M10 ($\frac{3}{8}$ "	8902	12185	62.37
LHBCSKM12	HBCSK12	M12 ($\frac{1}{2}$ "	10296	15961	62.37
HCF LHBCSKM16	HBCSK16	M16 ($\frac{5}{8}$ "	18951	31248	62.37

Hollo-Bolt Countersunk (Bolt Head) Stainless Steel

Product Code	European Code	Nominal Size	Tensile $F_{t,Rk}$ lbs	Shear $F_{v,Rk}$ lbs	Material Strength of Sleeve ksi
LHBSTCSKM08	HBSTCSK08	M8 ($\frac{5}{16}$ "	6025	6902	72.52
LHBSTCSKM10	HBSTCSK10	M10 ($\frac{3}{8}$ "	10341	11465	72.52
LHBSTCSKM12	HBSTCSK12	M12 ($\frac{1}{2}$ "	11982	14613	72.52
HCF LHBSTCSKM16	HBSTCSK16	M16 ($\frac{5}{8}$ "	22031	28775	72.52

- Sizes M16 ($\frac{5}{8}$ " and M20 ($\frac{3}{4}$ "), known as the Hollo-Bolt HCF, feature a patented High Clamping Force mechanism to produce three times more clamping force than the same sized product without the mechanism. The significance of clamping force and the superior performance of Lindapter's unique Hollo-Bolt HCF is illustrated on page 40.

Hollo-Bolt Flush Fit

Product Code	European Code	Nominal Size	Tensile $F_{t,Rk}$ lbs	Shear $F_{v,Rk}$ lbs	Material Strength of Sleeve ksi
LHBFFM08	HBFF08	M8 ($\frac{5}{16}$ "	5193	7396	62.37
LHBFFM10	HBFF10	M10 ($\frac{3}{8}$ "	8902	12185	62.37
LHBFFM12	HBFF12	M12 ($\frac{1}{2}$ "	10296	15961	62.37

Hollo-Bolt Flush Fit Stainless Steel

Product Code	European Code	Nominal Size	Tensile $F_{t,Rk}$ lbs	Shear $F_{v,Rk}$ lbs	Material Strength of Sleeve ksi
LHBSTFFM08	HBSTFF08	M8 ($\frac{5}{16}$ "	6025	6902	72.52
LHBSTFFM10	HBSTFF10	M10 ($\frac{3}{8}$ "	10341	11465	72.52
LHBSTFFM12	HBSTFF12	M12 ($\frac{1}{2}$ "	11982	14613	72.52

Hollo-Bolt Button Head / Security

Please contact Lindapter to discuss the available options.

Product Code	European Code	Nominal Size	Tensile $F_{t,Rk}$ lbs	Shear $F_{v,Rk}$ lbs	Material Strength of Sleeve ksi
LHBBH/ LHBFT/LHBPR	HBBH/HBFT /HBPR	M8 ($\frac{5}{16}$ "	5193	7396	62.37
LHBBH/ LHBFT/LHBPR	HBBH/HBFT /HBPR	M10 ($\frac{3}{8}$ "	8902	12185	62.37
LHBBH/ LHBFT/LHBPR	HBBH/HBFT /HBPR	M12 ($\frac{1}{2}$ "	10296	15961	62.37

- The characteristic values for the Hollo-Bolt listed in the above tables are for use when designing bolted connections to Eurocode 3 only, these are not standard safe working loads.

Hollo-Bolt lengths 1, 2 and 3 are covered by this ETA 10/0416. The characteristic values are used to determine the design resistance of the Hollo-Bolt. The design resistance is calculated by dividing the characteristic value by a partial factor γ_m2 . The partial factor is a nationally determined parameter (for example: $\gamma_m2 = 1.25$ in the UK, France, Germany and Italy). For Hollo-Bolt safe working loads with a factor of safety of 5:1 please refer to the Hollo-Bolt tables on page 42 of this brochure.

The characteristic values are valid for the Hollo-Bolt assembly itself, in any connection detail the design resistance of the connection may be limited to a lesser value. For example, when the thickness of the connected component is small, pull out failure may occur before failure of the Hollo-Bolt.

Design checks should be carried out on the section member to determine the static design resistance. The SCI Greenbook publication P.358 Joints in Steel construction, Simple Joints to Eurocode 3 contains a number of checks on the section. The characteristic values are only valid when the Hollo-Bolts are installed as per our installation instructions.

Hollo-Bolt Hexagonal & Countersunk (Bolt Head)

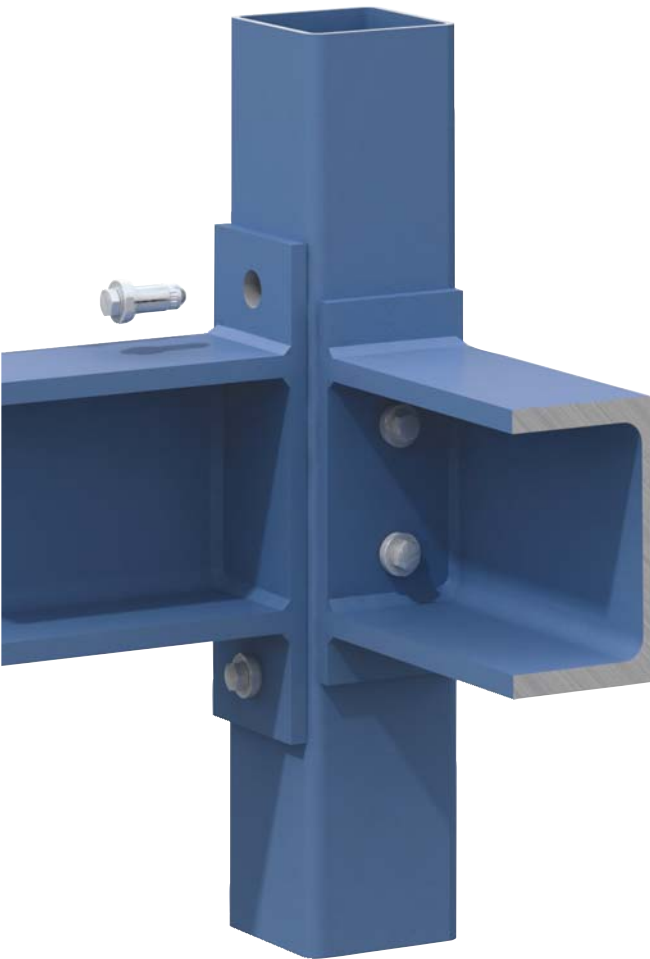

Drilling & Preparation

Ensure that holes are drilled in both the fixture and the section according to the drilling guidance below. Please note that clearance holes are slightly larger than standard bolt clearance holes to accommodate the sleeve and cone.

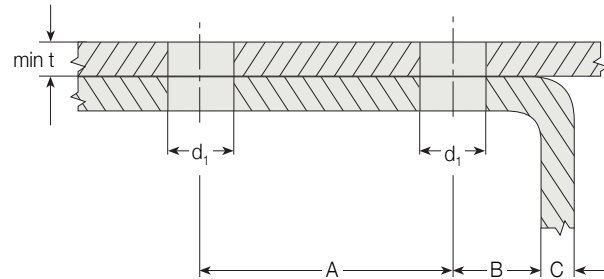

➤ Clearance holes can be drilled with a $-0 / +1/16$ " tolerance.

Hexagonal	Countersunk (Bolt Head)	Clearance Hole \varnothing d_1	Hole Distances		Edge Distances
			min A	min B	B + C
LHBM08	LHBCSKM08	9/16"	13/8"	1/2"	11/16"
LHBM10	LHBCSKM10	3/4"	19/16"	9/16"	7/8"
LHBM12	LHBCSKM12	13/16"	2"	3/4"	1"
LHBM16	LHBCSKM16	1 1/16"	2 3/16"	13/16"	1 5/16"
LHBM20	-	1 5/16"	2 3/4"	1"	1 5/16"

➤ Sizes M16 (5/8") and M20 (3/4") require the thickness of the outer ply (min t) to be at least 5/16". If necessary, spacer washers should be used beneath the collar to increase the thickness to 5/16".

INSTALLATION

1. Align pre-drilled fixture and section and insert Hollo-Bolt^{a)}.

2. Grip the Hollo-Bolt collar with an open ended wrench.

3. Using a calibrated torque wrench, tighten the central bolt to the recommended torque^{b)}.

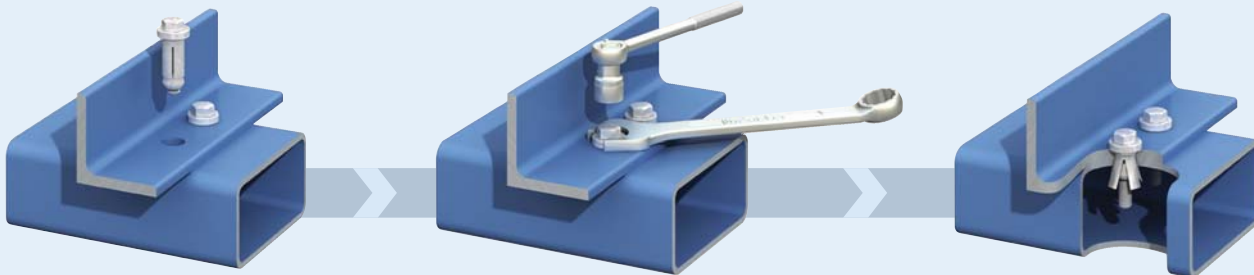

➤ a) Before tightening, ensure that the materials that are to be connected together are touching.

b) Power tools, such as an impact wrench, may be used to speed up the tightening of the Hollo-Bolt. However, when using power tools, always complete the tightening process with a torque wrench to ensure the correct torque is applied to the Hollo-Bolt.

Hollo-Bolt Flush Fit



Drilling & Preparation

Ensure that countersunk holes are drilled in the fixture, and standard holes are drilled in the section, according to the drilling guidance below. Please note that clearance holes are slightly larger than standard bolt clearance holes to accommodate the sleeve and cone.

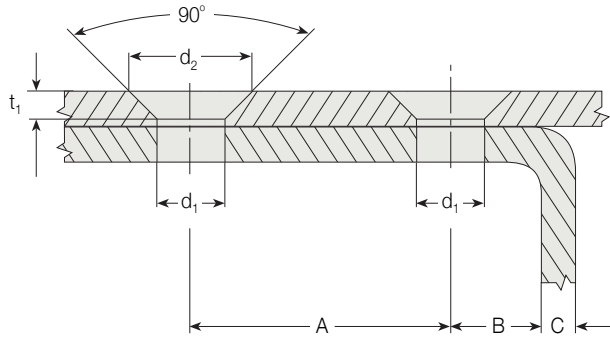

Type	Clearance Hole Ø	Countersunk Ø	Countersunk Depth	Hole Distances		Edge Distances
	d ₁	d ₂	t	min A	min B	B + C
LHBM08FF	9/16"	11/16"	1/4"	13/8"	1/2"	11/16"
LHBM10FF	3/4"	1 1/4"	1/4"	19/16"	9/16"	7/8"
LHBM12FF	13/16"	1 3/8"	5/16"	2"	3/4"	1"

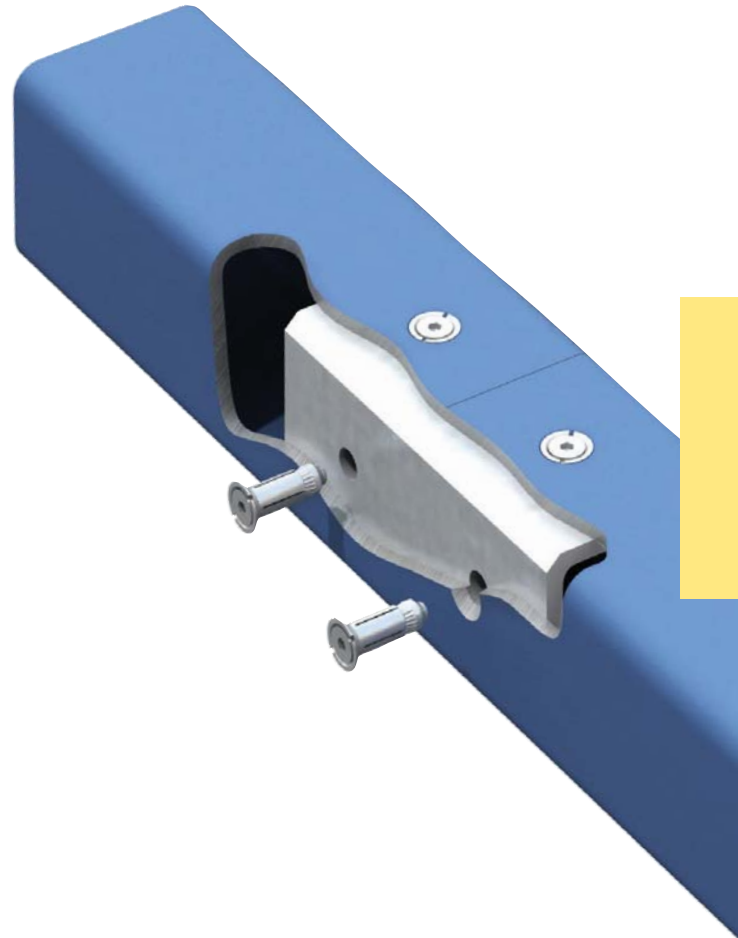

INSTALLATION

1. Align pre-drilled fixture and section and insert Hollo-Bolt[®].

2. Apply installation nut and grip with an open ended adjustable wrench.

3. Using a calibrated torque wrench, tighten the central countersunk bolt to the recommended torque^{b)}.

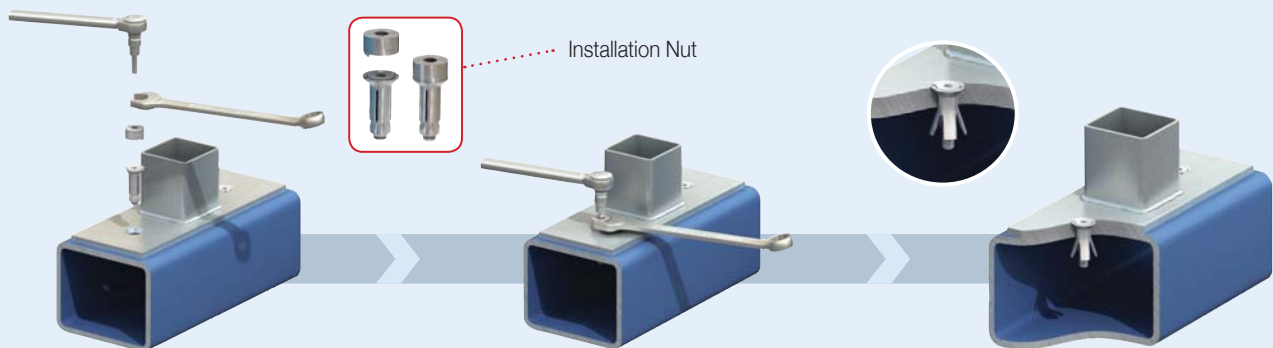

- a) Before tightening, ensure that the materials that are to be connected together are touching.
- b) Power tools, such as an impact wrench, may be used to speed up the tightening of the Hollo-Bolt. However, when using power tools, always complete the tightening process with a torque wrench to ensure the correct torque is applied to the Hollo-Bolt.

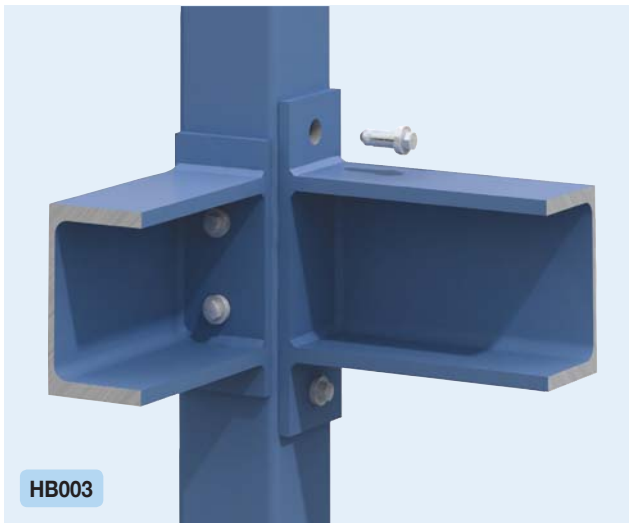
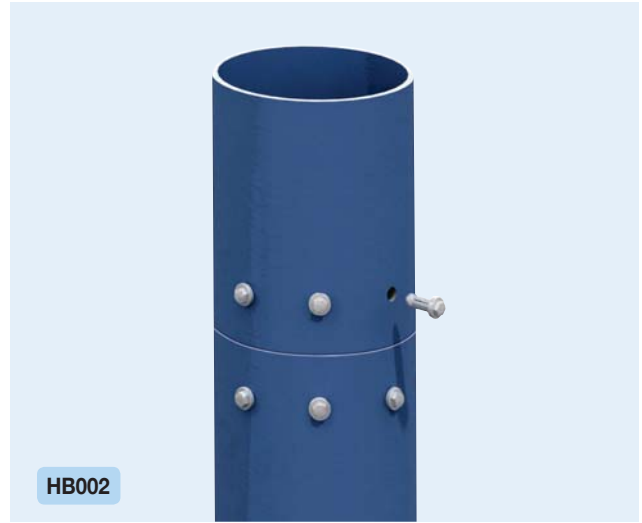
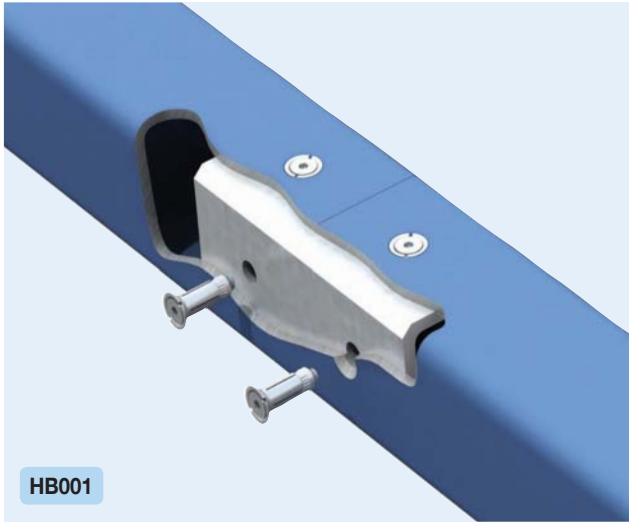

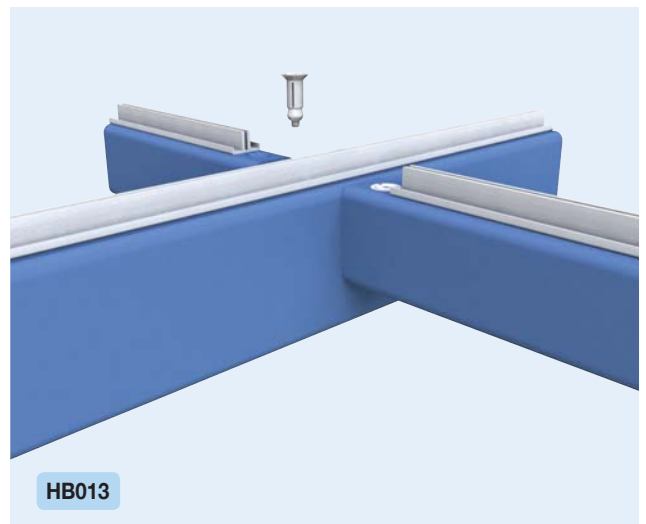
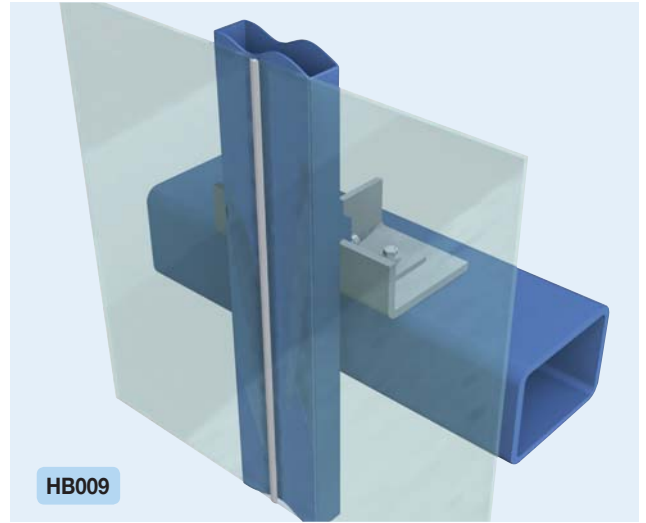
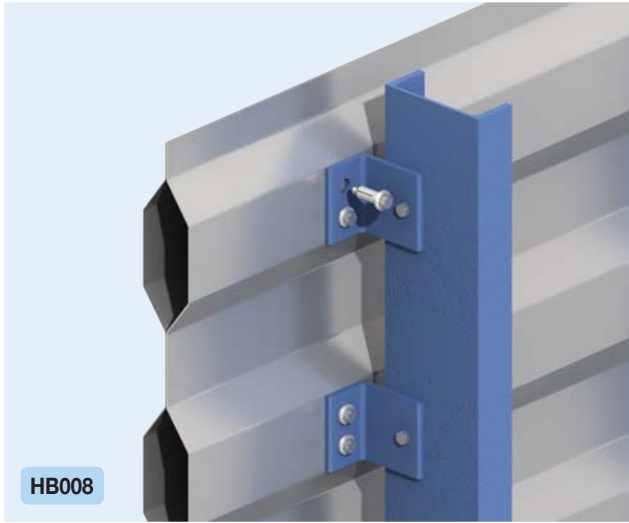

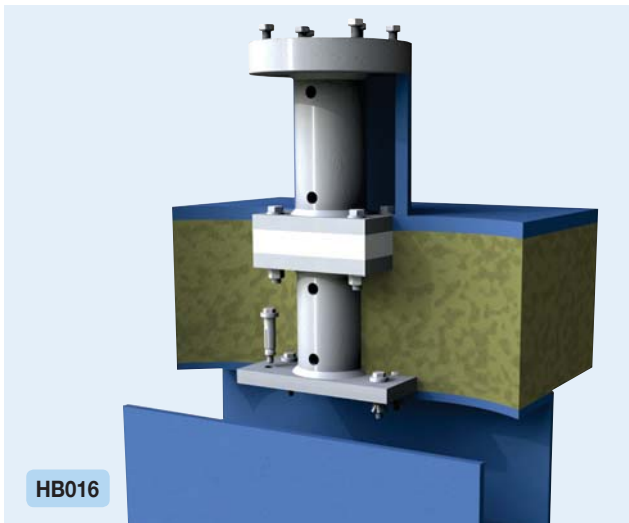

For more information on the Hollo-Bolt, including a Global Project Portfolio and FAQs, request the new Hollo-Bolt Brochure today.

To request a copy, email inquiries@LindapterUSA.com or visit the Hollo-Bolt website for a free download.



Visit the website:
www.hollo-bolt.com



Type LB2 - Lindibolt™ 2

Steel, bright zinc plated
Stainless Steel Grade 316

A self heading bolt suitable for connecting steelwork to hollow sections, tubes and where access is available from one side only. The Lindibolt 2 uses a standard clearance hole.

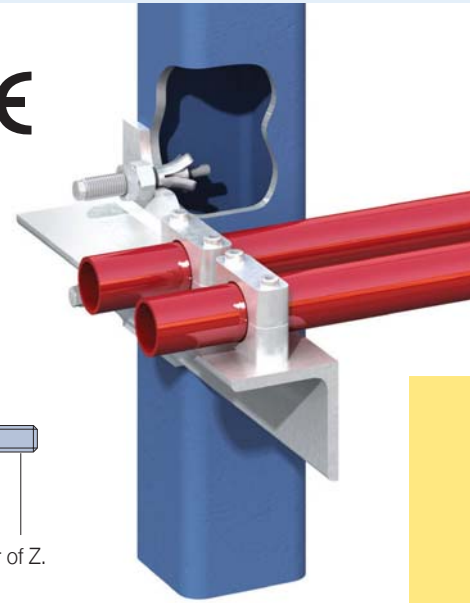
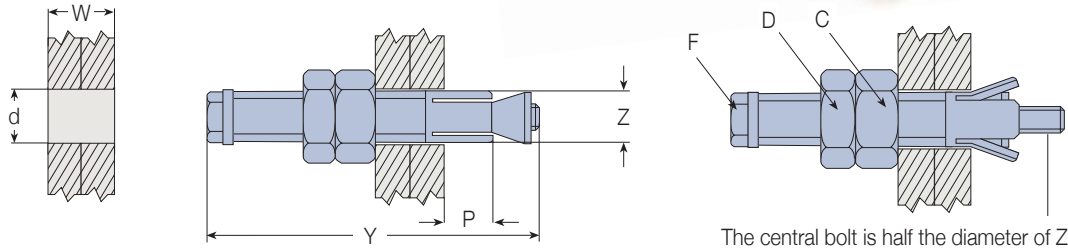

Safe Working Loads

Product Code	Lindibolt 2™		Hole Ø d	Safe Working Load ¹⁾		Clamping Length W	Projection P	Setscrew F		Nut C & Locknut D	
	Size Z	Length Y		Tensile lbs	Single Shear lbs			Torque ft lb	Nut A/F	Torque ft lb	Nut A/F
LLB037	M10 (3/8")	2 11/16"	7/16"	674	764	1/4" - 13/16"	5/16" - 3/8"	4	5/16"	15	11/16"
LLB050	M12 (1/2")	3 1/8"	9/16"	1124	1124	3/8" - 17/16"	3/8" - 1/2"	8	3/8"	23	3/4"
LLB062	M16 (5/8")	4 1/8"	11/16"	1798	2203	1/2" - 17/8"	1/2" - 5/8"	17	1/2"	60	1"
LLB075	M20 (3/4")	5"	13/16"	3147	3417	9/16" - 23/8"	9/16" - 13/16"	33	11/16"	95	1 1/4"
LLB100	M24 (1")	6 3/16"	1 1/16"	4496	5058	1 1/16" - 2 7/8"	1 1/16" - 1"	59	3/4"	150	1 7/16"

➤ The safe working loads, in both tension and shear shown above, are applicable to the Lindibolt only. Failure of the section, particularly on those with thin walls and a wide chord face, could occur at a lower figure and its strength should be checked.

Characteristic Values of Tensile and Shear Resistance

taken from ETA-11/0199 (www.lindapter.com/about/CE)

CE For designing to Eurocode 3 standard only

Lindibolt 2™

Product Code	Nominal Size	Tensile F _{t,Rk} lbs	Shear F _{v,Rk} lbs	Material Strength of Sleeve ksi
LLB037	M10 (3/8")	2698	3327	55
LLB050	M12 (1/2")	3979	4811	55
LLB062	M16 (5/8")	7756	9127	55
LLB075	M20 (3/4")	12252	14410	55
LLB100	M24 (1")	17782	20952	55

Lindibolt 2™ Stainless Steel

Product Code	Nominal Size	Tensile F _{t,Rk} lbs	Shear F _{v,Rk} lbs	Material Strength of Sleeve ksi
LLBST037	M10 (3/8")	3552	3080	73
LLBST050	M12 (1/2")	5216	4474	73
LLBST062	M16 (5/8")	10206	8543	73
LLBST075	M20 (3/4")	16119	13511	73
LLBST100	M24 (1")	23403	19626	73

➤ The Characteristic Values for the Lindibolt, listed in the tables immediately above, are for use when designing bolted connections to Eurocode 3 ONLY. These are not standard safe working loads. See page 38 for more information.

INSTALLATION

1. Set nut (C) at (W) plus projection (P). Tighten Locknut (D).
2. Align pre-drilled fixtures. Insert Lindibolt through both fixtures, cone end first.
3. Hold nut (C) with spanner and tighten bolt (F). Loosen off locknut (D) and tighten nut (C). Secure by re-tightening locknut (D).

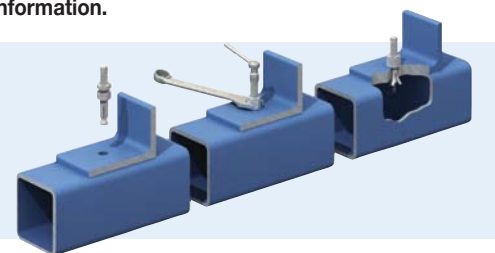



Concrete Decking Connections

Easy to install connections that allow building services, such as pipes or electrical cabling, to be suspended from pre-cast hollow core slabs or composite structural floor decking profiles.

Advantages include:

- Speed of installation
- Cost effective
- Ease of use
- No special tools required
- Adjustable and easily removable
- Approved safe working loads

It is important that the Type VN and all other Lindapter composite decking connections are installed only when the slab has been poured and the concrete reaches full strength.



Type TC - Toggle Clamp

Steel Strip, bright zinc plated

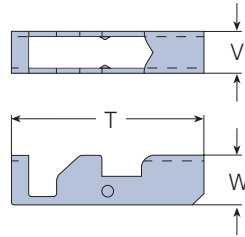

The Toggle Clamp is designed for service suspension from pre-cast hollow core slabs (minimum depth of core 3") as well as HSS, steel sheeting or purlins.

Product Code	Drop Rod Size	Hole Ø	Safe Working Load ¹⁾		Tightening Torque ft lb	Dimensions		
			(4:1 Factor of Safety)			T	W	Width V
			Tensile / 1 Rod lbs					
LTC037	3/8"	1"	550		7	2 11/16"	11/16"	9/16"

1) Subject to the strength of the concrete section.

■ Order example: LTC037

INSTALLATION

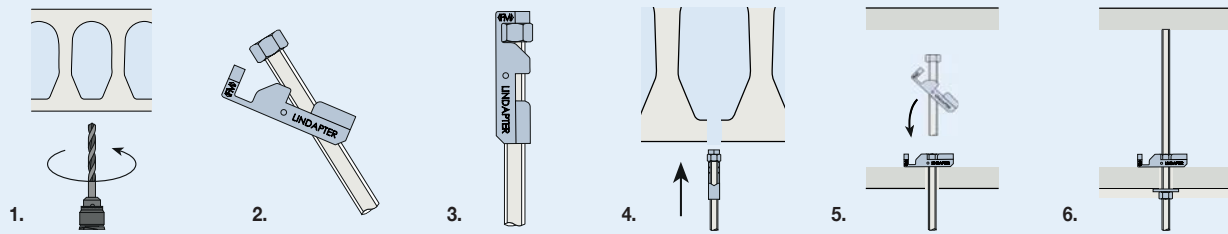

1. Drill hole. If toggle is to be used to support from pre-cast hollow core slab, ensure hole is central to hollow core.
2. Insert threaded rod through toggle, ensuring nut is flush with end of rod.
3. Align toggle parallel with rod so that nut engages into the retaining cavity.
4. Offer up the assembly, inserting the toggle body completely through the hole.
5. Shake rod so that toggle body locates horizontally across hole. Allow rod to drop down so that the nut locates in the seat in the toggle body.
6. Wind up rod to top of section as shown as high as possible. Secure the assembly with a nut and washer.

Note: The LTC037 is supplied with a special nut tapped 3/8" UNC. A standard 3/8" UNC nut will not fit.

Type VN - V-Nut

Mild steel, bright zinc plated

The V-Nut fits the re-entrant channel of several metal floor deckings.

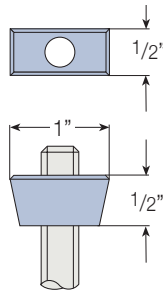

INSTALLATION

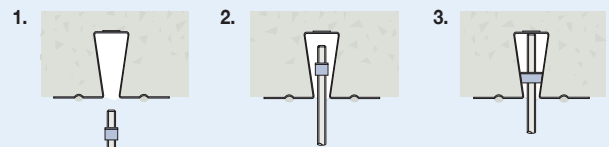

1. Screw VN onto threaded rod.
2. Insert VN and rod into re-entrant channel of decking.
3. Rotate both rod and VN through 90° so that tapered sides engage the sides of the channel.

➤ **If the decking profile is deformed/distorted, the fixing should not be installed. If in doubt, please contact Lindapter's Technical Support Department for advice.**

Product Code	Drop Rod Size (UNC)	Safe Working Load (4:1 Factor of Safety)		Tightening Torque ft lb
		Tensile / 1 Rod lbs		
LVN037	3/8"	472		7

■ Order example: LVN037



■ Pipe / Conduit Supports

Lindapter provides easy-to-install solutions for supporting building services from structural or secondary beams.

Examples include:

- The suspension of HVAC equipment
- Pipe work
- Fire protection/sprinkler systems
- Suspended ceilings
- Electrical equipment

The range of high quality connections are extremely adjustable, allowing the fast alignment of pipes and services for a quick, cost effective installation. As with all Lindapter connections, safety is paramount and where appropriate, independent approvals include VdS and FM (Factory Mutual), the American insurance organization globally recognized throughout the fire protection industry. The FM APPROVED mark, which is backed by third party scientific research and testing, verifies that Lindapter products conform to the highest standards.

Please note, for the installation of heavy duty pipe supports, such as those of the petrochemical industry, the steel connections in Section 1 of this catalog are more suitable. For more information, please contact Lindapter who will be pleased to design a connection to your specific requirement.

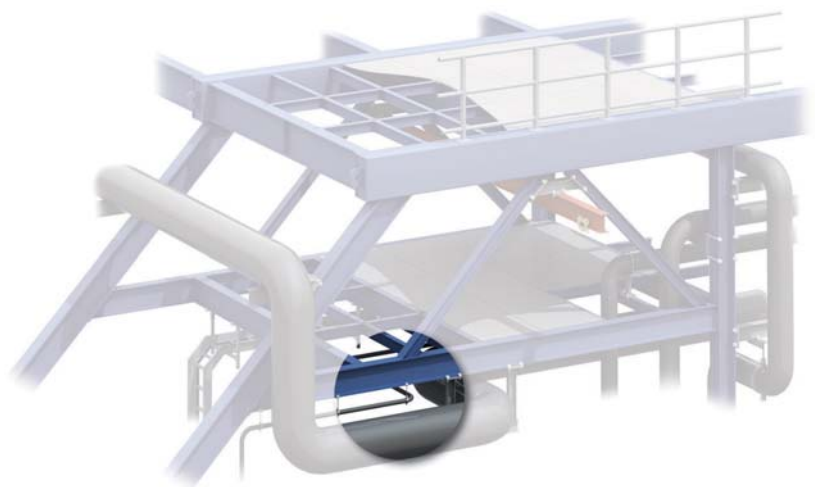

Type FLS

High Grade Alloy Steel, bright zinc plated

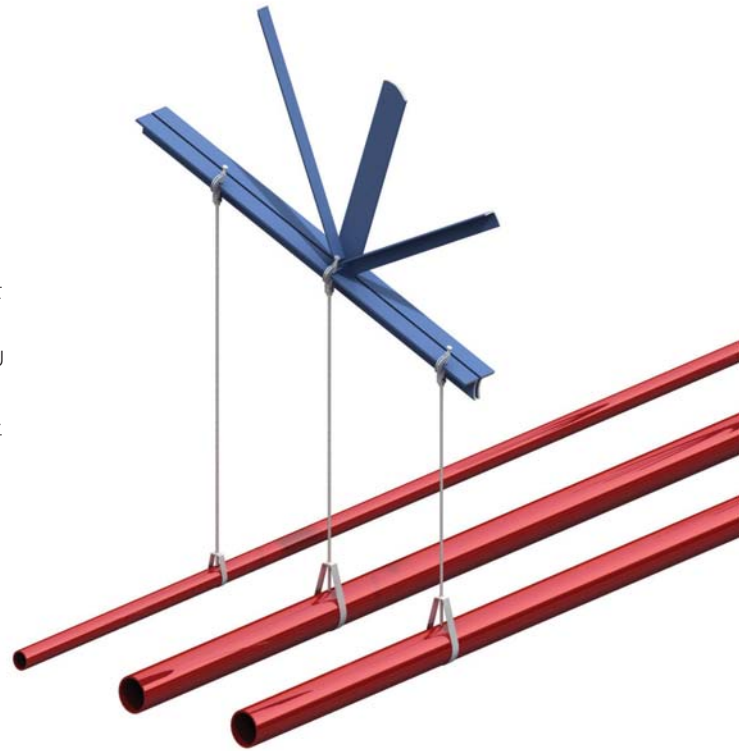
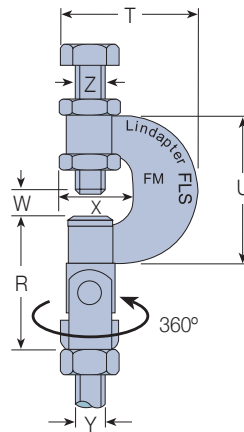

A flange clamp with swivel unit for parallel and sloping flanges. Supplied with a high tensile setscrew for secure grip.

Product Code	Thread Y	Safe Working Load (4:1 Factor of Safety)			Clamping Thickness W	Tightening Torque (ft lb)			Dimensions			
		Tensile/≤ 25° lbs	Tensile/> 25° to ≤ 45° lbs	Setscrew Z		Setscrew Z	Nut N	R	T	U	X	Width
LFLS037	3/8"	550	330	1/8" - 11/16"	M10	13	13	2 3/16"	2 1/8"	2 1/4"	1 1/16"	11/16"

Order example: LFLS037

Approved Applications

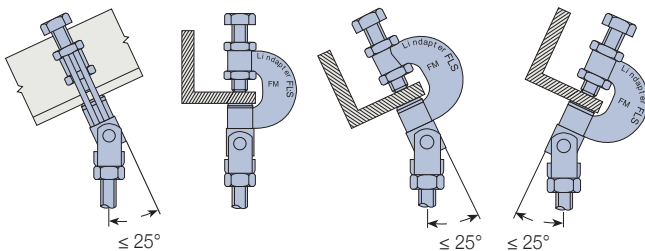

General Applications - Parallel Flanges only

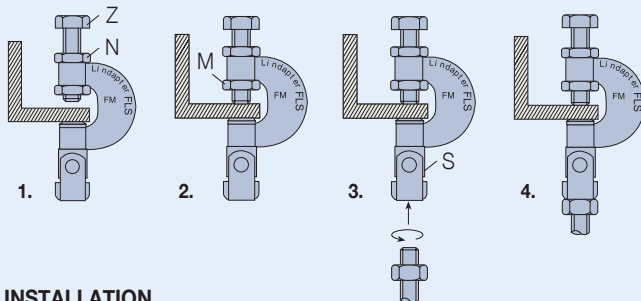
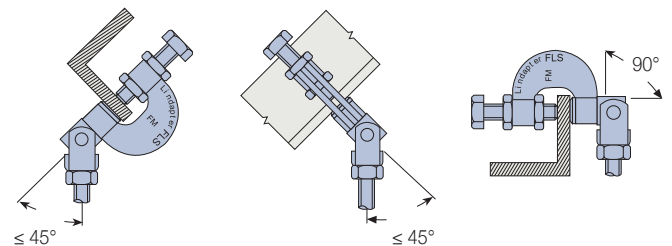

INSTALLATION

1. Locate FLS onto flange.
2. Ensuring lug on locknut locates into main body, tighten down setscrew (Z) and then tighten upper locknut (N).
3. Install threaded rod by screwing into nut located in nut basket (S). Ensure full thread capture.
4. Secure assembly in nut basket (S) from beneath using a locknut (not supplied).

➤ Ensure that the cup point setscrew always grips on the tapered side of the flange.

Type FL

Malleable iron, bright zinc plated

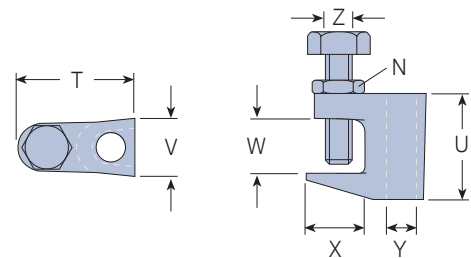
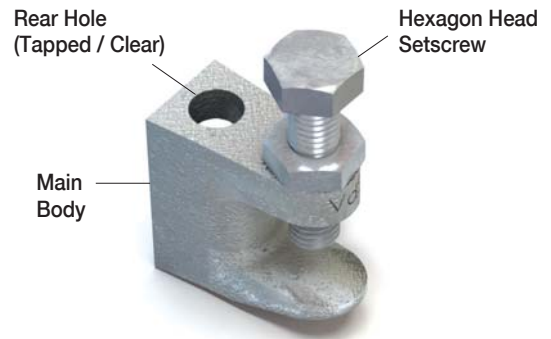
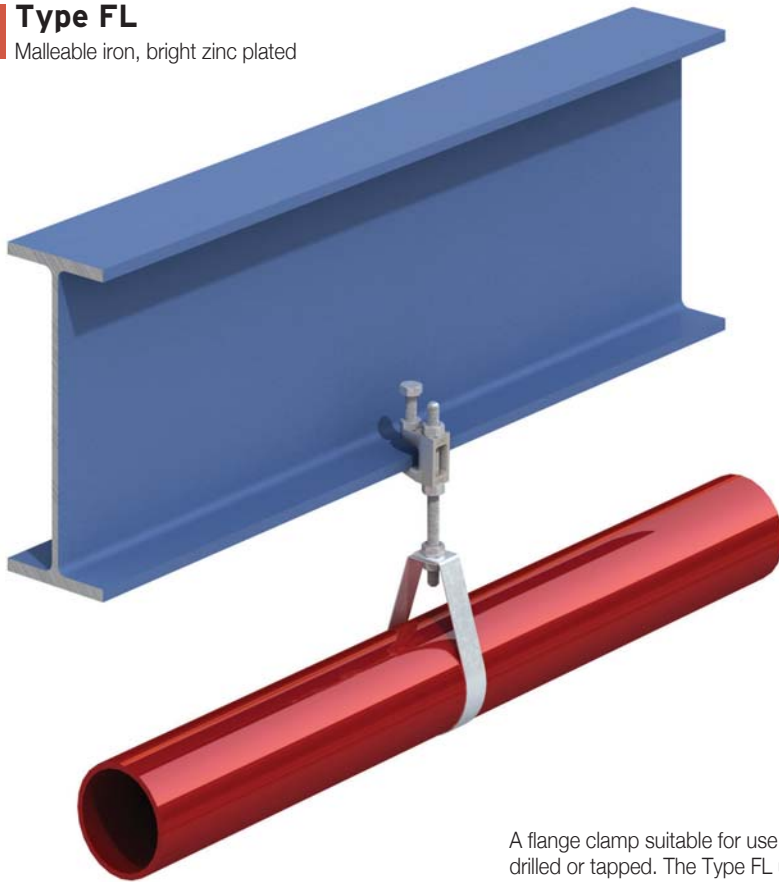

A flange clamp suitable for use with parallel or tapered flange beams, supplied with the rear hole drilled or tapped. The Type FL uses a hexagon head, high tensile cup point setscrew for secure grip. Can be used with Type SW – Swivel Unit (see page 55) when connecting to inclined sections.

Product Code	Clear Hole Ø	Safe Working Load			Clamping Thickness W	Set-screw Z	Tightening Torque		T	Dimensions		
		Clear Y	Tapped Y	(4:1 Factor of Safety) Tensile lbs			Set-screw Z ft lb	Lock-nut N ft lb		U	X	Width V
LFL037C LFL037T	7/16"	3/8"	540	1/8" - 3/4"	M10 (3/8")	6	16	13/4"	19/16"	7/8"	7/8"	
LFL050C LFL050T	1/2"	1/2"	700	1/8" - 7/8"	M10 (3/8")	6	16	2"	113/16"	11/8"	1"	

Order example: LFL037C

INSTALLATION

- Slide FL onto beam flange and tighten setscrew to the recommended torque. Guideline: tighten the setscrew finger tight and then apply a further quarter turn (90°) with spanner.
- Tighten the locknut (N) to the recommended torque.

➤ On tapered flanges, the cup point setscrew has to grip on the inside of the flange.

Type LC

Malleable iron, bright zinc plated

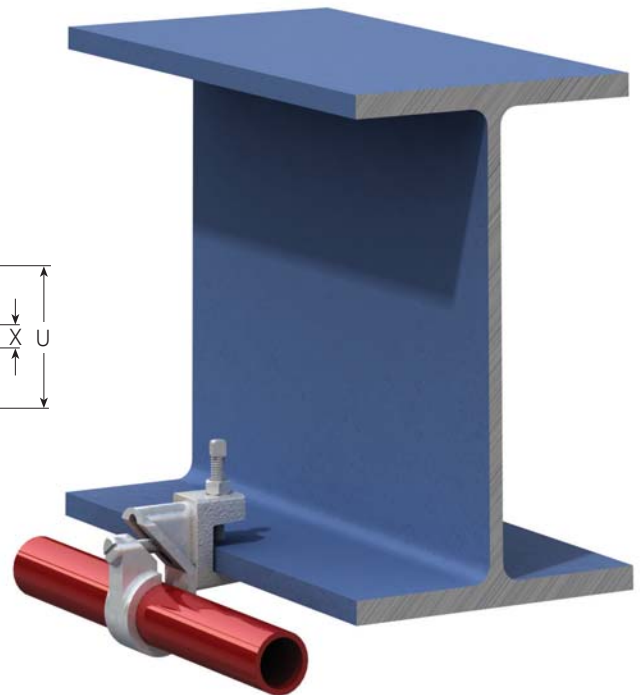
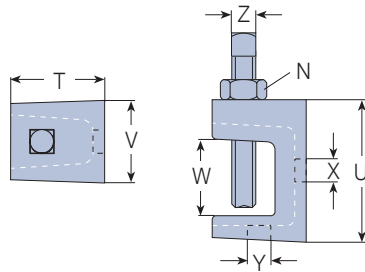
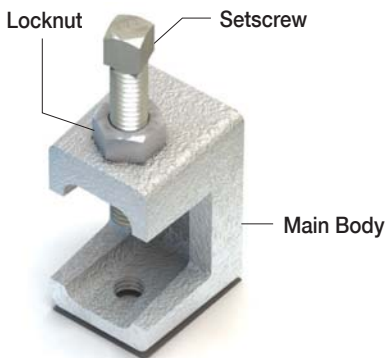

A flange clamp with tapped holes in position X and Y to accept threaded rod or cable clips. For parallel or tapered flanges. Supplied with a high tensile cup point setscrew.

▶ Installation see page 54 – Type FL

Product Code	Thread X & Y	Safe Working Load (4:1 Factor of Safety)		Clamping Thickness W	Setscrew Z	Setscrew Z	Locknut N	Tightening Torque		
		Tensile / in Pos. X lbs	Tensile / in Pos. Y lbs					Dimensions T	Dimensions U	Dimensions Width V
LLC025	1/4"	40	135	1/8" - 13/16"	M6 (1/4")	3	3	1"	17/16"	7/8"

■ Order example: LLC025

Type SW - Swivel Unit

High Grade Alloy Steel, bright zinc plated

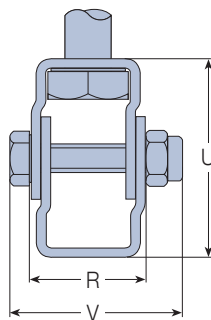

Type FL (supplied separately)

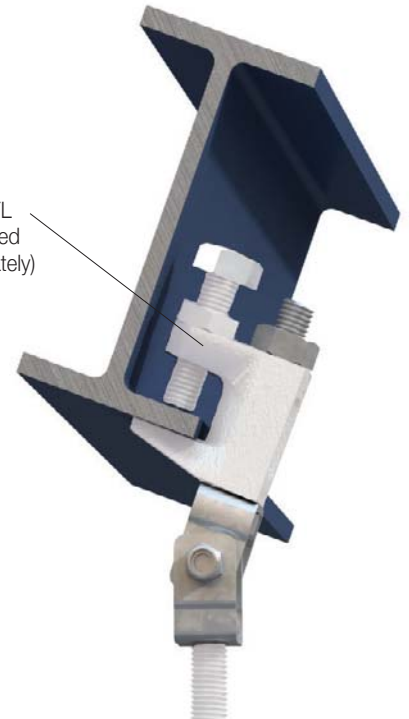

Swivel unit for applications on inclined beams. Can be used with a clear hole Type FL. Supplied complete with a high tensile M10 x 19/16" setscrew and nut.

Product Code	Drop Rod	Safe Working Load (4:1 Factor of Safety)			Tightening Torque ft lb	Dimensions		
		Tensile lbs	Max. Inclination	Rotation		U	R	With Bolt Width V
LSW037	M10 (3/8")	540	18°	360°	8	13/4"	1"	13/8"

■ Order example: LSW037

Type F3

Malleable iron,
hot dip galvanized

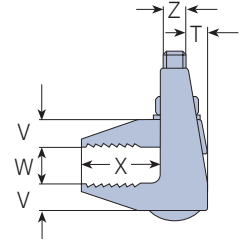
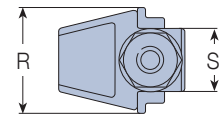
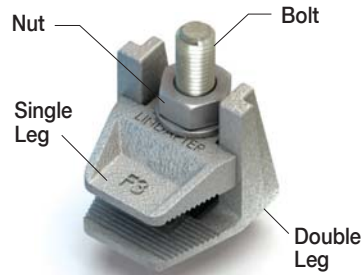

A two part flange clamp with large clamping range. The bolt can be substituted with either drop rod or J bolts. Supplied with or without bolt.

➔ For parallel flanges only.

Product Code		Bolt/Thread Z	Safe Working Load (4:1 Factor of Safety) Tensile / 1 bolt lbs	Clamping Thickness W		Tightening Torque ft lb	Dimensions				
With Bolt	No Bolt			min	max		S	T	V	X	Width R
LF3037WB	LF3037NB	M10	270	1/16"	13/16"	15	7/8"	5/16"	3/8"	1"	11/2"
LF3050WB	LF3050NB	M12	450	3/32"	19/16"	29	1 1/8"	3/8"	1/2"	13/8"	115/16"
LF3062WB	LF3062NB	M16	900	3/32"	23/16"	69	1 3/8"	1/2"	5/8"	113/16"	23/8"
LF3075WB	LF3075NB	M20	1350	5/32"	23/4"	130	1 3/4"	9/16"	3/4"	23/16"	3"

■ Order example: LF3037WB

Type F3-BICC

Malleable iron, hot dip galvanized

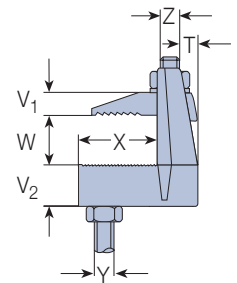
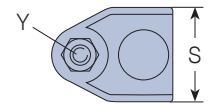
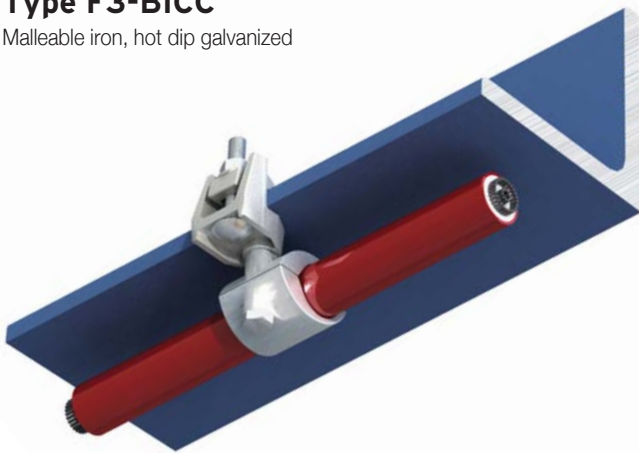

A two part flange clamp which fixes claw type cable cleats directly beneath the flange. Supplied with bolt.

➔ For parallel flanges only.

Product Code	Bolt Z	Safe Working Load (4:1 Factor of Safety) Tensile lbs	Clamping Thickness W	Thread Y	Tightening Torque ft lb	Dimensions				
						T	V ₁	V ₂	X	Width S
F3M10BICCA	M10	270	13/16"	M10	15	5/16"	3/8"	5/8"	13/16"	11/2"

■ Order example: F3M10BICCA

Type HW/HC

Malleable iron, bright zinc plated / hot dip galvanized

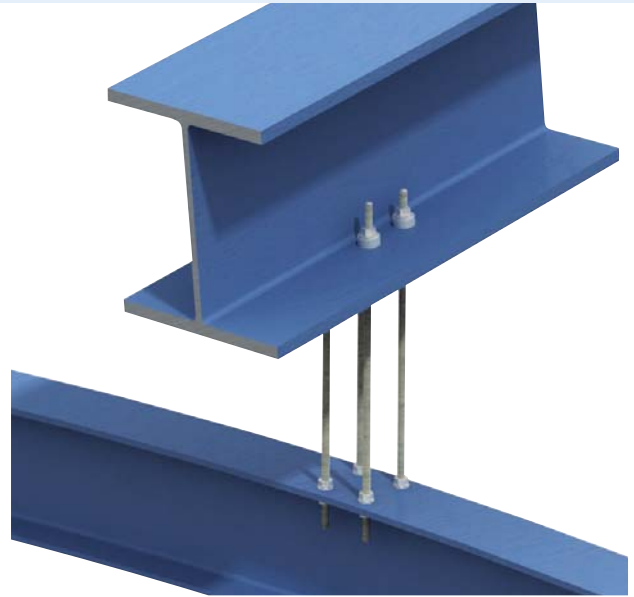
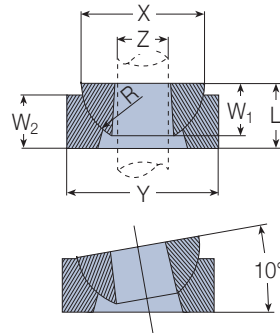
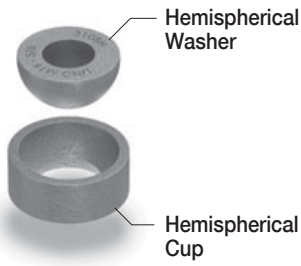

For vertical suspension on angled surface of up to 10° swing either side of the vertical. The hemispherical washer (HW) can be used without the cup. Loads are subject to applications. Please contact Lindapter.

Washer	Product Code		Rod Size Z	Washer		Dimensions Cup		Washer & Cup	
	Washer	Cup		X	W ₁	Y	W ₂	R	L
LHW037	LHC037	LHC037	3/8"	1"	1/2"	1 1/4"	1/2"	1/2"	9/16"
LHW050	LHC050	LHC050	1/2"	1 1/8"	1/2"	1 3/8"	1/2"	9/16"	5/8"
LHW062	LHC062	LHC062	5/8"	1 3/8"	5/8"	1 5/8"	5/8"	11/16"	3/4"
LHW075	LHC075	LHC075	3/4"	1 3/4"	3/4"	2 1/8"	3/4"	7/8"	15/16"
LHW100	LHC100	LHC100	1"	2 1/4"	1"	2 5/8"	1"	1 1/8"	1 1/4"

Order example: LHW037 + LHC037

Type Z10

Mild steel, bright zinc plated



A purlin clip to suit a large range of purlin sections. Can be used with Type SW – Swivel Unit (see page 55) for use on inclined purlins.

Product Code	Purlins	Rod	Safe Working Load (3:1 Factor of Safety)	
			Tensile lbs	Tightening Torque ft lb
LZ037	Kingspan Multibeam 2 & 3	3/8"	44	6
LZ037	Metsec	3/8"	22 - 44	6
LZ037	Zeta	3/8"	53	6

Order example: LZ037

INSTALLATION

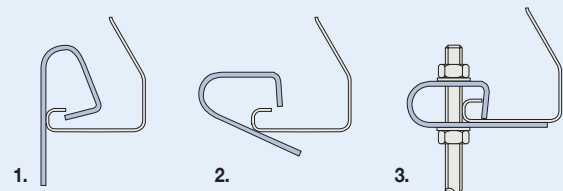

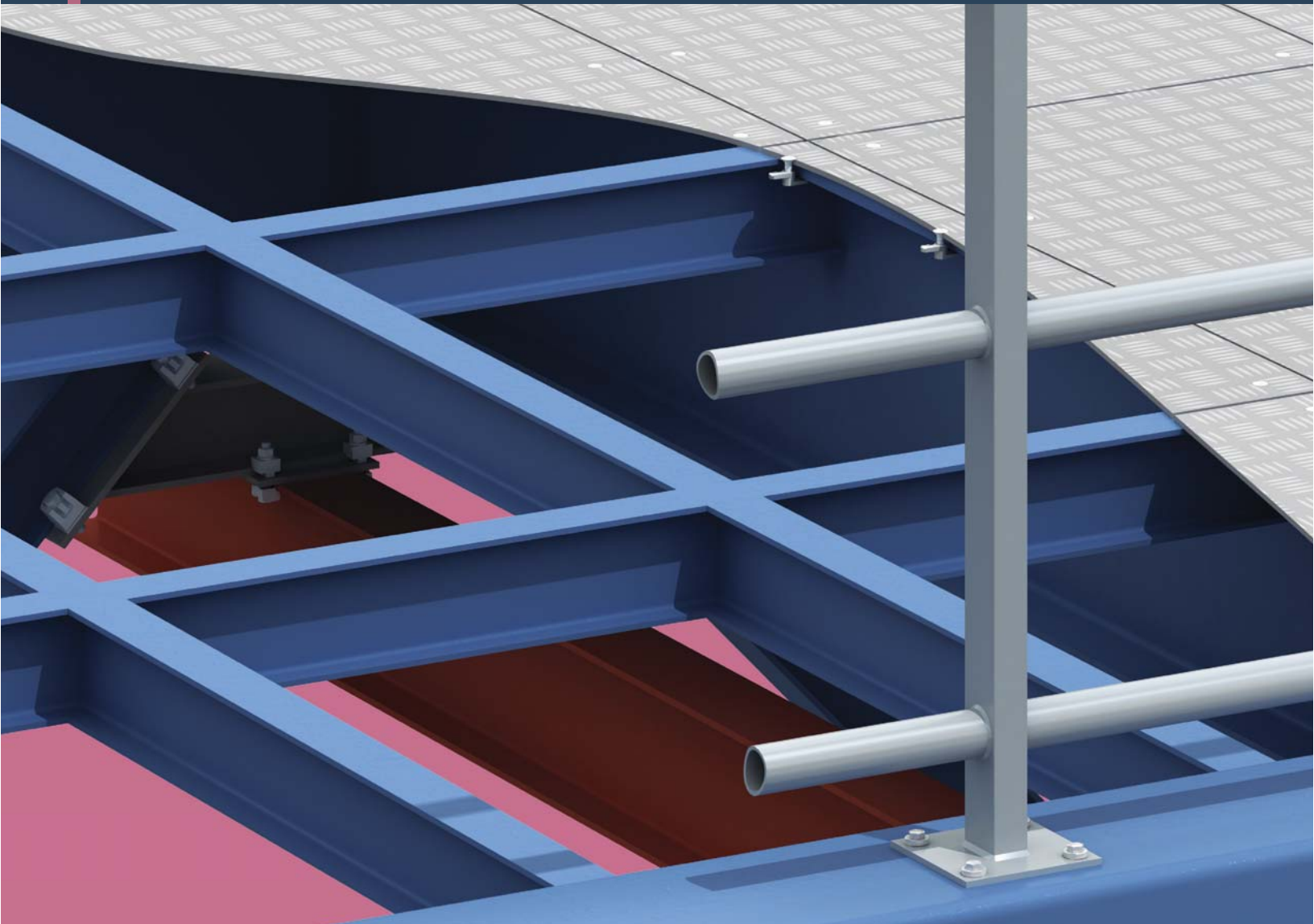

■ Steel Floor Connections

Lindapter applied its connection concept to steel flooring and invented a range of innovative products making it possible to install checker plate or open bar grating without on-site drilling or welding, for a fast, low cost operation.

Access to the underside of the flooring is not required, eliminating the need for costly scaffolding or elevated floors. Installation can be carried out quickly and safely from above, often by one person, significantly reducing installation costs.

Both the Floorfast® & Grate-Fast® carry the Lloyd's Register Type Approval in respect of their resistance to shock and vibration. Hot working is not required, creating particular benefits in hazardous environments such as petrochemical and processing industries, while a rapid and cost efficient installation is beneficial in any industry.



Type FF - Floorfast®

Malleable iron, bright zinc plated / hot dip galvanized
Stainless Steel Grade 316

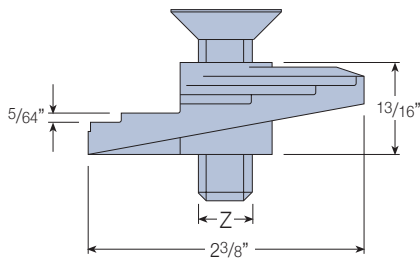
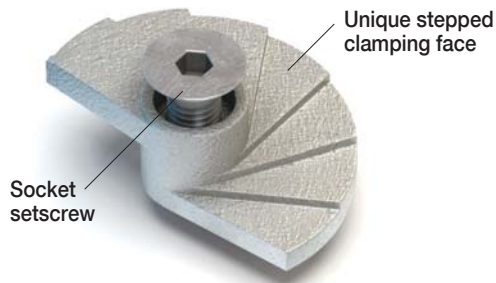

An innovative connection for securing checker plate flooring to supporting steel. The product consists of a malleable iron body casting with a countersunk socket screw. The eccentric stepped web of the casting allows it to lock under the steel, providing full face contact when torque is applied. For thicker flanges, a ferrule can be supplied. Lloyd's Register Type Approval for vibration resistance.

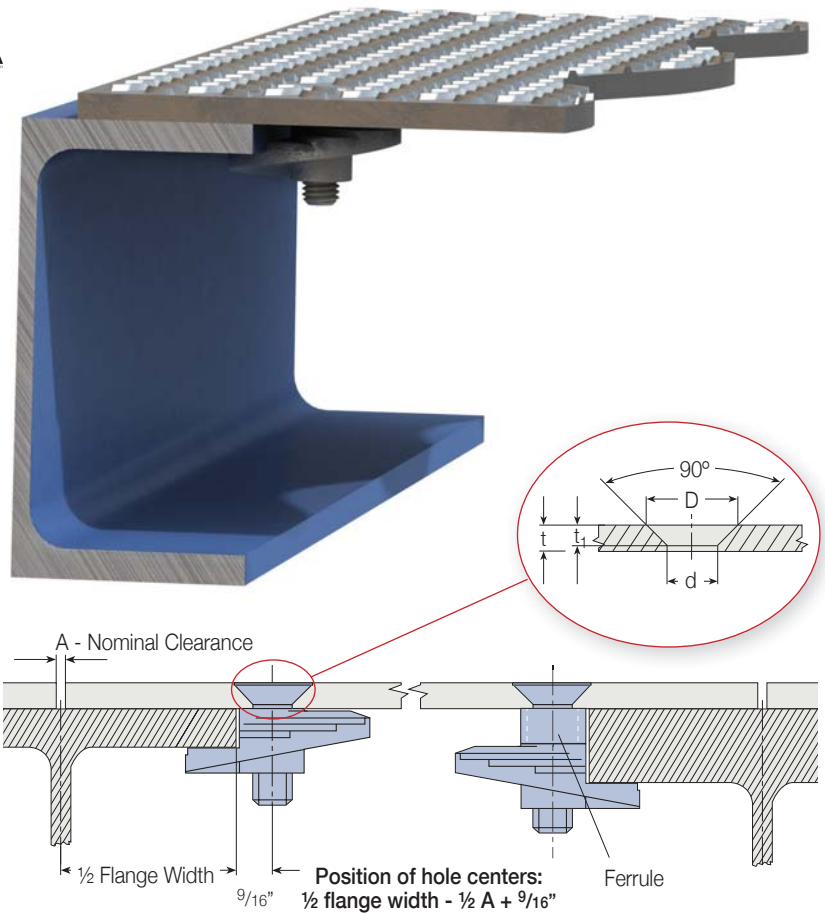

Product Code	Bolt ¹⁾ Z	Floorplate Thickness t	Flange Thickness			Hole Ø d	Countersunk				Tightening Torque ft lb	Hexagon Key inches	
			Standard	With Ferrule ²⁾			Countersunk Ø for Bolt		Countersunk Depth for Bolt				
				10mm (3/8")	20mm (3/4")		30mm (1 3/16")	BZP D	HDG	BZP t ₁			HDG
LFF031	M8	1/8" - 1/2"	1/8" - 5/8"	1/2" - 1"	15/16" - 13/8"	15/16" - 13/4"	3/8"	11/16"	-	3/16"	-	8	3/16"
LFF037	M10	3/16" - 1/2"	1/8" - 5/8"	1/2" - 1"	15/16" - 13/8"	15/16" - 13/4"	7/16"	13/16"	3/4"	3/16"	3/16"	16	1/4"
LFF050	M12	1/4" - 1/2"	1/8" - 5/8"	1/2" - 1"	15/16" - 13/8"	15/16" - 13/4"	9/16"	1"	15/16"	1/4"	3/16"	16	5/16"

1) Hot dip galvanized M10 and M12 versions are supplied with a slotted countersunk screw.

2) To order Floorfast with a ferrule, simply add ferrule size to product code (see order example right).

■ Order example: LLFF050, with 10mm ferrule

INSTALLATION

1. Pre-assemble Floorfast on underside of floorplate with stepped surface facing inwards.
2. Align castings with straight edge parallel to the edge of the plate and hand tighten.
3. Lay floorplate into position
4. Using a hexagon key, release the countersunk screw one full turn.
5. Tighten down the countersunk socket screw.

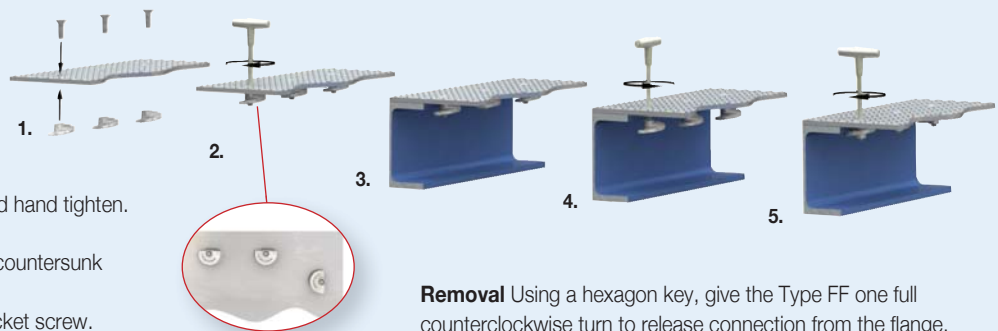

Removal Using a hexagon key, give the Type FF one full counterclockwise turn to release connection from the flange.

Type GF - Grate-Fast®

Top Hat: Stainless Steel Grade 304 (LGF031)
Mild Steel, hot dip galvanized (LGF037 (OSB) & LGF037)

Body: Malleable iron, sheraplex (LGF031)
Mild Steel, hot dip galvanized (LGF037 (OSB) & LGF037)

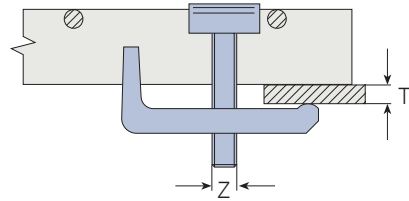
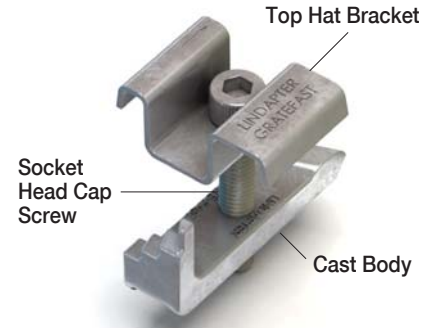
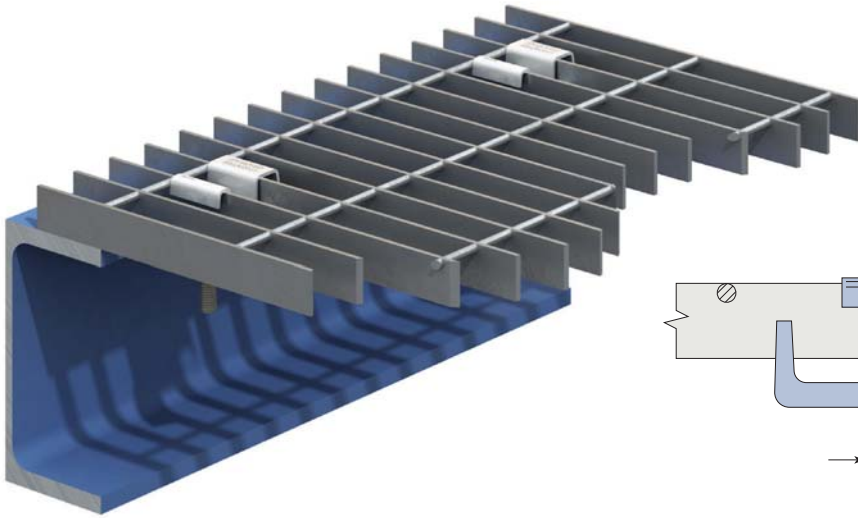

A grating connection for rectangular open bar gratings, with superior clamping force from the cast body. Lloyd's Register Type Approval for vibration resistance.

LGF031 for GRP grating with stainless steel top-hat bracket, sheraplex coated body and socket head screw.

LGF037 (OSB) features an oversized bracket to fit various grating profiles. Galvanized for corrosion resistance.

LGF037 for use with 1³/₁₆" width floor grating bars only. Galvanized for corrosion resistance.

LGF031 / LGF037 (OSB)

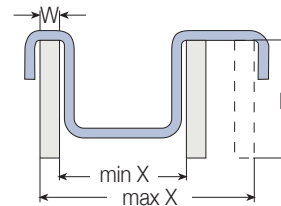

LGF037

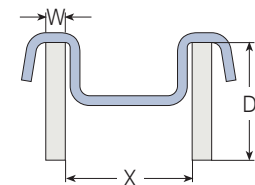

Product Code	Bolt Z	Flange T	Grating Bar Depth D	Grating Bar Width W	Bar Distance X	Body Width	Tightening Torque	Hexagon Key
LGF031	M8	1/8" - 3/4"	7/8" - 1 1/2"	3/16" - 3/8"	3/4" - 1 7/8"	5/8"	4	6mm (1/4")
LGF037 (OSB) ¹⁾	M10	1/8" - 3/4"	13/16" - 13/16"	1/8" - 1/4"	1" - 1 3/4"	3/4"	8	8mm (5/16")
LGF037 ¹⁾	M10	1/8" - 3/4"	3/4" - 1 1/4"	1/8" - 1/4"	1 3/16"	3/4"	8	8mm (5/16")

1) May be supplied with a hex head screw.

Order example: LGF031

INSTALLATION

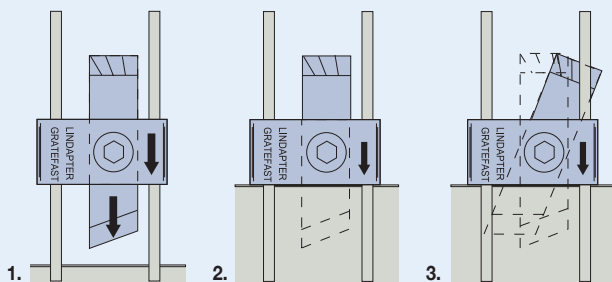

1. Position pre-assembled Grate-Fast with body between grating bars and nose pointing toward the steel. The arrows on the top hat bracket should also be pointing toward supporting steel and bracket itself resting on the bearing bars.
2. Slide Grate-Fast toward steel until nose fits under the beam flange. Where necessary, adjust body/screw to approximate flange thickness/ grating depth.
3. Tighten cap screw. The Grate-Fast body will automatically rotate until it locks under the bearing bar, with the nose under the flange. Continue tightening to the recommended torque.

C-Channel

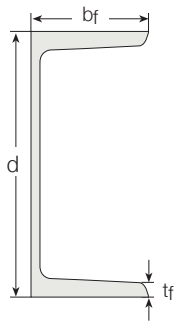

C-Channels				C-Channels				C-Channels			
Beam Designation	Depth d	Flange Width bf	Flange Edge Thickness tf	Beam Designation	Depth d	Flange Width bf	Flange Edge Thickness tf	Beam Designation	Depth d	Flange Width bf	Flange Edge Thickness tf
C15 x 50	15"	3 1/16"	3/8"	C9 x 20	9"	2 5/8"	1/4"	C6 x 8.2	6"	1 7/8"	3/16"
C15 x 40	15"	3 1/2"	3/8"	C9 x 15	9"	2 1/2"	1/4"	C5 x 9	5"	1 7/8"	3/16"
C15 x 33.9	15"	3 3/8"	3/8"	C9 x 13.4	9"	2 3/8"	1/4"	C5 x 6.7	5"	1 3/4"	3/16"
C12 x 30	12"	3 3/16"	1/4"	C8 x 18.75	8"	2 1/2"	3/16"	C4 x 7.25	4"	1 3/4"	3/16"
C12 x 25	12"	3 1/16"	5/16"	C8 x 13.75	8"	2 3/8"	3/16"	C4 x 5.4	4"	1 9/16"	1/8"
C12 x 20.7	12"	2 15/16"	5/16"	C8 x 11.5	8"	2 1/4"	1/4"	C3 x 6	3"	1 5/8"	3/16"
C10 x 30	10"	3 1/16"	1/4"	C7 x 12.25	7"	2 3/16"	3/16"	C3 x 5	3"	1 1/2"	1/8"
C10 x 25	10"	2 7/8"	1/4"	C7 x 9.8	7"	2 1/16"	1/4"	C3 x 4.1	3"	1 3/8"	1/8"
C10 x 20	10"	2 3/4"	1/4"	C6 x 13	6"	2 3/16"	3/16"				
C10 x 15.3	10"	2 5/8"	1/4"	C6 x 10.5	6"	2 1/16"	1/4"				

S-Beam

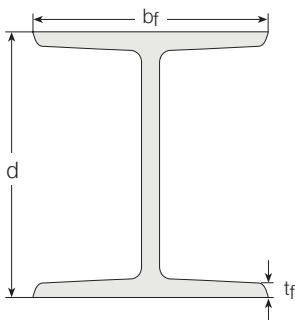

S-Beams				S-Beams				S-Beams			
Beam Designation	Depth d	Flange Width bf	Flange 'tf' to nearest 1/16"	Beam Designation	Depth d	Flange Width bf	Flange 'tf' to nearest 1/16"	Beam Designation	Depth d	Flange Width bf	Flange 'tf' to nearest 1/16"
S24 x 121	24 1/2"	8"	3/4"	S15 x 50	15"	5 5/8"	3/8"	S7 x 15.3	7"	3 5/8"	1/4"
S24 x 106	24 1/2"	7 7/8"	3/4"	S15 x 42.9	15"	5 1/2"	3/8"	S6 x 17.25	6"	3 5/8"	3/16"
S24 x 100	24"	7 1/4"	9/16"	S12 x 50	12"	5 1/2"	7/16"	S6 x 12.5	6"	3 3/8"	3/16"
S24 x 90	24"	7 1/8"	9/16"	S12 x 40.8	12"	5 1/4"	7/16"	S5 x 14.75	5"	3 1/4"	3/16"
S24 x 80	24"	7"	9/16"	S12 x 35	12"	5 1/8"	7/16"	S5 x 10	5"	3"	3/16"
S20 x 96	20 1/4"	7 1/4"	5/8"	S12 x 31.8	12"	5"	5/16"	S4 x 9.5	4"	2 3/4"	3/16"
S20 x 86	20 1/4"	7"	5/8"	S10 x 35	10"	5"	5/16"	S4 x 7.7	4"	2 5/8"	3/16"
S20 x 75	20"	6 3/8"	1/2"	S10 x 25.4	10"	4 5/8"	5/16"	S3 x 7.5	3"	2 1/2"	1/8"
S20 x 66	20"	6 1/4"	1/2"	S8 x 23	8"	4 1/8"	1/4"	S3 x 5.7	3"	2 3/8"	1/8"
S18 x 70	18"	6 1/4"	7/16"	S8 x 18.4	8"	4"	1/4"				
S18 x 54.7	18"	6"	7/16"	S7 x 20	7"	3 7/2"	1/4"				

W-Beam

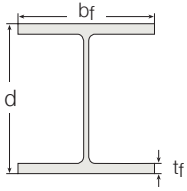

W-Beams				W-Beams				W-Beams			
Beam Designation	Depth d	Flange Width bf	Flange Edge Thickness tf	Beam Designation	Depth d	Flange Width bf	Flange Edge Thickness tf	Beam Designation	Depth d	Flange Width bf	Flange Edge Thickness tf
W44 x 335	44"	153/4"	13/4"	W36 x 135	351/2"	12"	13/16	W24 x 492	295/4"	141/8"	39/16"
W44 x 290	435/8"	157/8"	19/16"	W33 x 354	351/2"	161/8"	21/16"	W24 x 408	281/2"	133/4"	3"
W44 x 262	435/16"	153/4"	17/16"	W33 x 318	351/8"	16"	17/8"	W24 x 335	271/2"	131/2"	21/2"
W44 x 230	4215/16"	153/4"	11/4"	W33 x 291	347/8"	157/8"	13/4"	W24 x 279	263/4"	131/4"	21/16"
W40 x 593	43"	163/4"	31/4"	W33 x 263	341/2"	153/4"	19/16"	W24 x 250	263/8"	131/8"	17/8"
W40 x 503	421/16"	167/16"	23/4"	W33 x 241	341/8"	157/8"	13/8"	W24 x 229	26"	131/8"	13/4"
W40 x 431	411/4"	161/4"	23/8"	W33 x 221	337/8"	153/4"	11/4"	W24 x 207	253/4"	13"	19/16"
W40 x 372	405/8"	161/16"	21/16"	W33 x 201	335/8"	153/4"	11/8"	W24 x 192	251/2"	13"	17/16"
W40 x 321	401/16"	157/8"	13/4"	W33 x 169	337/8"	111/2"	11/4"	W24 x 176	251/4"	127/8"	15/16"
W40 x 297	397/8"	157/8"	15/8"	W33 x 152	331/2"	115/8"	11/16"	W24 x 162	25"	13"	11/4"
W40 x 277	393/4"	157/8"	19/16"	W33 x 141	331/4"	111/2"	15/16"	W24 x 146	243/4"	127/8"	11/16"
W40 x 249	393/8"	153/4"	17/16"	W33 x 130	331/8"	111/2"	7/8"	W24 x 131	241/2"	127/8"	15/16"
W40 x 215	39"	153/4"	11/4"	W33 x 118	327/8"	111/2"	3/4"	W24 x 117	241/4"	123/4"	7/8"
W40 x 199	385/8"	153/4"	11/16"	W30 x 477	341/4"	157/8"	3"	W24 x 104	24"	123/4"	3/4"
W40 x 174	381/4"	153/4"	13/16"	W30 x 391	331/4"	155/8"	27/16"	W24 x 103	241/2"	9"	1"
W40 x 466	427/16"	125/8"	215/16"	W30 x 326	323/8"	153/8"	21/16"	W24 x 94	241/4"	91/8"	7/8"
W40 x 392	419/16"	123/8"	21/2"	W30 x 292	32"	151/4"	17/8"	W24 x 84	241/8"	9"	3/4"
W40 x 331	4013/16"	123/16"	21/8"	W30 x 261	315/8"	151/8"	15/8"	W24 x 76	237/8"	9"	11/16"
W40 x 278	403/16"	12"	113/16"	W30 x 235	311/4"	15"	11/2"	W24 x 68	233/4"	9"	9/16"
W40 x 264	40"	12"	13/4"	W30 x 211	31"	151/8"	15/16"	W24 x 62	233/4"	7"	9/16"
W40 x 235	393/4"	117/8"	19/16"	W30 x 191	305/8"	15"	13/16"	W24 x 55	235/8"	7"	1/2"
W40 x 211	393/8"	113/4"	17/16"	W30 x 173	301/2"	15"	11/16"	W21 x 201	23"	125/8"	15/8"
W40 x 183	39"	113/4"	11/4"	W30 x 148	305/8"	101/2"	13/16"	W21 x 182	223/4"	121/2"	11/2"
W40 x 167	385/8"	113/4"	1"	W30 x 132	301/4"	101/2"	1"	W21 x 166	221/2"	123/8"	13/8"
W40 x 149	381/4"	113/4"	13/16"	W30 x 124	301/8"	101/2"	15/16"	W21 x 147	22"	121/2"	11/8"
W36 x 848	421/2"	181/8"	41/2"	W30 x 116	30"	101/2"	7/8"	W21 x 132	217/8"	121/2"	11/16"
W36 x 798	42"	18"	45/16"	W30 x 108	297/8"	101/2"	3/4"	W21 x 122	215/8"	123/8"	15/16"
W36 x 650	401/2"	175/8"	39/16"	W30 x 99	295/8"	101/2"	11/16"	W21 x 111	211/2"	123/8"	7/8"
W36 x 527	391/4"	171/4"	215/16"	W30 x 90	291/2"	103/8"	9/16"	W21 x 101	213/8"	121/4"	13/16"
W36 x 439	381/4"	17"	27/16"	W27 x 539	321/2"	151/4"	39/16"	W21 x 93	215/8"	83/8"	15/16"
W36 x 393	371/4"	167/8"	23/16"	W27 x 448	313/8"	15"	3"	W21 x 83	213/8"	83/8"	13/16"
W36 x 359	373/8"	163/4"	2"	W27 x 368	303/8"	145/8"	21/2"	W21 x 73	211/4"	81/4"	3/4"
W36 x 328	371/8"	165/8"	17/8"	W27 x 307	295/8"	141/2"	21/16"	W21 x 68	211/8"	81/4"	11/16"
W36 x 300	363/4"	165/8"	111/16"	W27 x 258	29"	141/4"	13/4"	W21 x 62	21"	81/4"	5/8"
W36 x 280	361/2"	165/8"	19/16"	W27 x 235	285/8"	141/4"	15/8"	W21 x 57	21"	61/2"	5/8"
W36 x 260	361/4"	161/2"	17/16"	W27 x 217	283/8"	141/8"	11/2"	W21 x 55	203/4"	81/4"	1/2"
W36 x 245	361/4"	161/2"	13/8"	W27 x 194	281/8"	14"	15/16"	W21 x 50	207/8"	61/2"	1/2"
W36 x 230	357/8"	161/2"	11/4"	W27 x 178	273/4"	141/8"	13/16"	W21 x 44	205/8"	61/2"	7/16"
W36 x 256	373/8"	121/4"	13/4"	W27 x 161	275/8"	14"	11/16"	W18 x 311	223/8"	12"	23/4"
W36 x 232	371/8"	121/8"	19/16"	W27 x 146	273/8"	14"	1"	W18 x 283	217/8"	117/8"	21/2"
W36 x 210	363/4"	121/8"	13/8"	W27 x 129	275/8"	10"	11/8"	W18 x 258	211/2"	113/4"	25/16"
W36 x 194	361/2"	121/8"	11/4"	W27 x 114	271/4"	101/8"	15/16"	W18 x 234	21"	115/8"	21/8"
W36 x 182	363/8"	121/8"	13/16"	W27 x 102	271/8"	10"	13/16"	W18 x 211	205/8"	111/2"	115/16"
W36 x 170	361/8"	12"	11/8"	W27 x 94	267/8"	10"	3/4"	W18 x 192	203/8"	111/2"	13/4"
W36 x 160	36"	12"	1"	W27 x 84	263/4"	10"	5/8"	W18 x 175	20"	113/8"	19/16"
W36 x 150	357/8"	12"	15/16"								

W-Beam

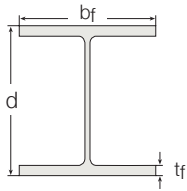

W-Beams				W-Beams				W-Beams			
Beam Designation	Depth d	Flange Width bf	Flange Edge Thickness tf	Beam Designation	Depth d	Flange Width bf	Flange Edge Thickness tf	Beam Designation	Depth d	Flange Width bf	Flange Edge Thickness tf
W18 x 158	193/4"	111/4"	17/16"	W14 x 159	15"	155/8"	13/16"	W12 x 19	121/8"	4"	3/8"
W18 x 143	191/2"	111/4"	15/16"	W14 x 145	143/4"	151/2"	11/16"	W12 x 16	12"	4"	1/4"
W18 x 130	191/4"	111/8"	13/16"	W14 x 132	145/8"	143/4"	1"	W12 x 14	117/8"	4"	1/4"
W18 x 119	19"	111/4"	11/16"	W14 x 120	141/2"	145/8"	15/16"	W10 x 112	113/8"	103/8"	11/4"
W18 x 106	183/4"	111/4"	15/16"	W14 x 109	143/8"	145/8"	7/8"	W10 x 100	111/8"	103/8"	11/8"
W18 x 97	185/8"	111/8"	7/8"	W14 x 99	141/8"	145/8"	3/4"	W10 x 88	107/8"	101/4"	1"
W18 x 86	183/8"	11"	3/4"	W14 x 90	14"	141/2"	11/16"	W10 x 77	105/8"	101/4"	7/8"
W18 x 76	181/4"	11"	11/16"	W14 x 82	141/4"	101/8"	7/8"	W10 x 68	103/8"	101/8"	3/4"
W18 x 71	181/2"	75/8"	13/16"	W14 x 74	141/8"	101/8"	13/16"	W10 x 60	101/4"	101/8"	11/16"
W18 x 65	183/8"	75/8"	3/4"	W14 x 68	14"	10"	3/4"	W10 x 54	101/8"	10"	5/8"
W18 x 60	181/4"	71/2"	11/16"	W14 x 61	137/8"	10"	5/8"	W10 x 49	10"	10"	9/16"
W18 x 55	181/8"	71/2"	5/8"	W14 x 53	137/8"	8"	11/16"	W10 x 45	101/8"	8"	5/8"
W18 x 50	18"	71/2"	9/16"	W14 x 48	133/4"	8"	5/8"	W10 x 39	97/8"	8"	1/2"
W18 x 46	18"	6"	5/8"	W14 x 43	135/8"	8"	1/2"	W10 x 33	93/4"	8"	7/16"
W18 x 40	177/8"	6"	1/2"	W14 x 38	145/8"	63/4"	1/2"	W10 x 30	101/2"	53/4"	1/2"
W18 x 35	173/4"	6"	7/16"	W14 x 34	14"	63/4"	7/16"	W10 x 26	103/8"	53/4"	7/16"
W16 x 100	17"	103/8"	1"	W14 x 30	137/8"	63/4"	3/8"	W10 x 22	101/8"	53/4"	3/8"
W16 x 89	163/4"	103/8"	7/8"	W14 x 26	137/8"	5"	7/16"	W10 x 19	101/4"	4"	3/8"
W16 x 77	161/2"	101/4"	3/4"	W14 x 22	133/4"	5"	5/16"	W10 x 17	101/8"	4"	5/16"
W16 x 67	163/8"	101/4"	11/16"	W12 x 336	167/8"	133/8"	215/16"	W10 x 15	10"	4"	1/4"
W16 x 57	163/8"	71/8"	11/16"	W12 x 305	163/8"	131/4"	211/16"	W10 x 12	97/8"	4"	3/16"
W16 x 50	161/4"	71/8"	5/8"	W12 x 279	157/8"	131/8"	21/2"	W8 x 67	9"	81/4"	15/16"
W16 x 45	161/8"	7"	9/16"	W12 x 252	153/8"	13"	21/4"	W8 x 58	83/4"	81/4"	13/16"
W16 x 40	16"	7"	1/2"	W12 x 230	15"	127/8"	21/16"	W8 x 48	81/2"	81/8"	11/16"
W16 x 36	157/8"	7"	7/16"	W12 x 210	143/4"	123/4"	17/8"	W8 x 40	81/4"	81/8"	9/16"
W16 x 31	157/8"	51/2"	7/16"	W12 x 190	143/8"	125/8"	13/4"	W8 x 35	81/8"	8"	1/2"
W16 x 26	153/4"	51/2"	3/8"	W12 x 170	14"	125/8"	19/16"	W8 x 31	8"	8"	7/16"
W14 x 808	227/8"	181/2"	51/8"	W12 x 152	133/4"	121/2"	13/8"	W8 x 28	8"	61/2"	7/16"
W14 x 730	223/8"	177/8"	415/16"	W12 x 136	133/8"	123/8"	11/4"	W8 x 24	77/8"	61/2"	3/8"
W14 x 665	215/8"	175/8"	41/2"	W12 x 120	131/8"	123/8"	11/8"	W8 x 21	81/4"	51/4"	3/8"
W14 x 605	207/8"	173/8"	43/16"	W12 x 106	127/8"	121/4"	1"	W8 x 18	81/8"	51/4"	5/16"
W14 x 550	201/4"	171/4"	313/16"	W12 x 96	123/4"	121/8"	7/8"	W8 x 15	81/8"	4"	5/16"
W14 x 500	195/8"	17"	31/2"	W12 x 87	121/2"	121/8"	13/16"	W8 x 13	8"	4"	1/4"
W14 x 455	19"	167/8"	33/16"	W12 x 79	123/8"	121/8"	3/4"	W8 x 10	77/8"	4"	3/16"
W14 x 426	185/8"	163/4"	31/16"	W12 x 72	121/4"	12"	11/16"	W6 x 25	63/8"	61/8"	7/16"
W14 x 398	181/4"	165/8"	27/8"	W12 x 65	121/8"	12"	5/8"	W6 x 20	61/4"	6"	3/8"
W14 x 370	177/8"	161/2"	211/16"	W12 x 58	121/4"	10"	5/8"	W6 x 15	6"	6"	1/4"
W14 x 342	171/2"	163/8"	21/2"	W12 x 53	12"	10"	9/16"	W6 x 16	61/4"	4"	3/8"
W14 x 311	171/8"	161/4"	21/4"	W12 x 50	121/4"	81/8"	5/8"	W6 x 12	6"	4"	1/4"
W14 x 283	163/4"	161/8"	21/16"	W12 x 45	12"	8"	9/16"	W6 x 9	57/8"	4"	3/16"
W14 x 257	163/8"	16"	17/8"	W12 x 40	12"	8"	1/2"	W5 x 19	51/8"	5"	7/16"
W14 x 233	16"	157/8"	13/4"	W12 x 35	121/2"	61/2"	1/2"	W5 x 16	5"	5"	3/8"
W14 x 211	153/4"	153/4"	19/16"	W12 x 30	123/8"	61/2"	7/16"	W4 x 13	41/8"	4"	3/8"
W14 x 193	151/2"	153/4"	17/16"	W12 x 26	121/4"	61/2"	3/8"				
W14 x 176	151/4"	155/8"	15/16"	W12 x 22	121/4"	4"	7/16"				

Steel Connections

Project: Alexander Hamilton Bridge Refurbishment
Location: Route 95, New York
Product: Type AF
Application: Temporary support connections



image: bridgeandturne.com

Hollow Section (HSS) Connections

Project: Salt River Fields Spring Training Facility
Location: Scottsdale, Arizona
Product: Type HB - Hollo-Bolt HCF Hexagonal
Application: Structural connections of floodlighting frames

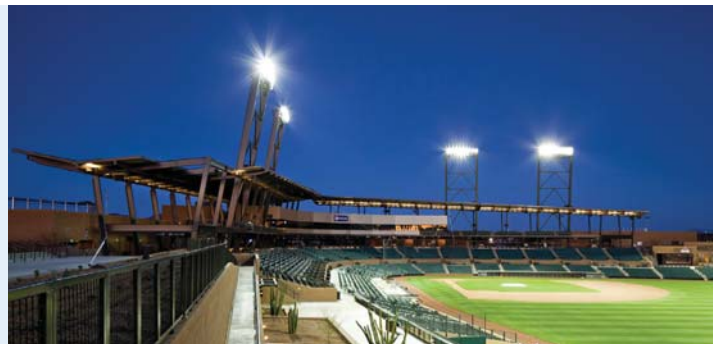

Pipe / Conduit Supports

Project: Manhattan Bridge
Location: New York City
Product: Type F3
Application: Pipe supports



Steel Floor Connections

Project: Hartfield-Jackson Airport
Location: Atlanta
Product: Type GF – Grate-Fast
Application: Securing maintenance walkway

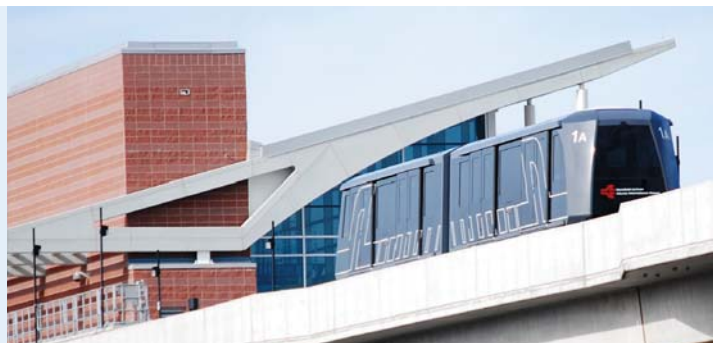

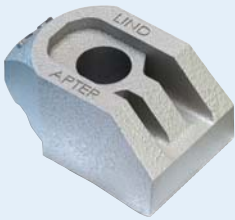

Lindapter Type AF connections were used on the major refurbishment and widening of the Alexander Hamilton Bridge to connect temporary support systems for cantilevered roadways. Type AF clamps were ideal for the varying connection angles of the application due to their high performance in friction and tensile.

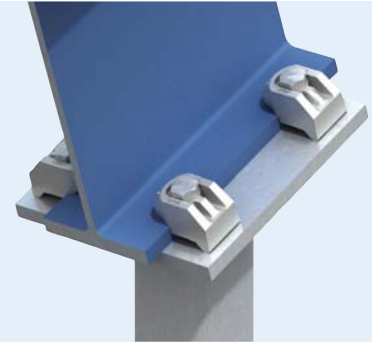

Lindapter Holo-Bolts were used to connect the large end plates of the horizontal structural tube cross beams to the vertical tubular frame of the lighting rigs. The M20 (3/4") structural steel expansion bolts featured Lindapter's patented High Clamping Force (HCF) mechanism to increase clamping force by up to three times for a more secure connection.

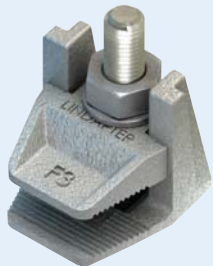

Lindapter Pipe Support connections are often specified for securing pipework due to the ease of installation and high adjustability. In this case, the Type F3 was used to connect piping carrying fibre optic cable for high-speed internet. No drilling, welding or power was required, simplifying the installation across the 1480ft span of the iconic Manhattan Bridge.

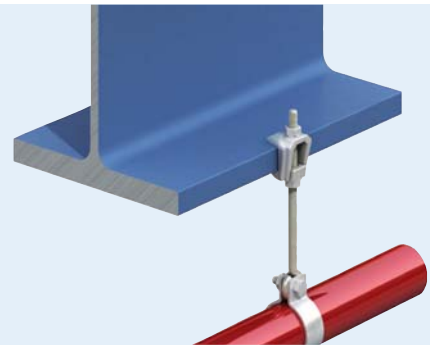

Lindapter Grate-Fast connections were used to secure open bar grating maintenance walkways along 1.5 miles of light rail track running between three new stations at the Hartfield-Jackson Airport. The Grate-Fast floor connector enabled the flooring to be attached to the supporting steel members in a matter of seconds without requiring specialist tools or skilled labor, saving time and money in comparison to traditional bolted connections.

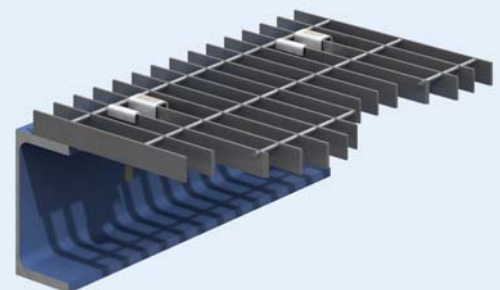

Steel Connections

Project: Target Field Ballpark
Location: Minneapolis, Minnesota
Product: Type LR
Application: Secured the canopy soffit



Image: Wayne Krudva / Minnesota Twins

Hollow Section (HSS) Connections

Project: Kimmel Center for the Performing Arts
Location: Philadelphia, Pennsylvania
Product: Type HB - Hollo-Bolt Hexagonal
Application: Structural connections on the steel framed roof



Image: Jeff Goldberg/Festo, courtesy of Kimmel Center

Pipe Supports (Heavy Duty)

Project: ExxonMobil Refinery
Location: Houston, Texas
Product: Type LR
Application: Pipe supports



Steel Floor Connections

Project: Benjamin Franklin Bridge
Location: Philadelphia, Pennsylvania
Product: Type GF – Grate-Fast
Application: Securing maintenance platforms





The stadium features a 1,988 ton steel sunshade canopy that sweeps around the stadium, with an 80,000 ft² glistening soffit safely suspended overhead with Lindapter steel connections. The adjustable Type LR clamp allowed contractors to quickly connect the soffit framework to the structural sections, despite the variations in beam size and connection angle.



Lindapter Hollo-Bolts connect the arched trusses that form the 150ft high barrel vault roof. The connection design consisted of splice joints inside the adjoining pre-drilled hollow sections, allowing the Hollo-Bolts to be simply inserted and tightened with a torque wrench for a rapid installation. The design also eradicated the possibility of tube deformation that can be associated with through-bolting if the bolts are over tightened.



In addition to the Pipe / Conduit Supports product line, Lindapter's Steel Connections are often used for heavy duty pipe supports. At this major refinery in Houston, Type LR clamps were used to secure a new pipeline, spanning several thousand feet to existing cantilever beams. As drilling or welding was not required, potential fire hazards and the associated hot work permits were avoided. Lindapter's connection enabled pipe guides to be installed in a continuously operational facility, with no interference to the refinery's productivity.

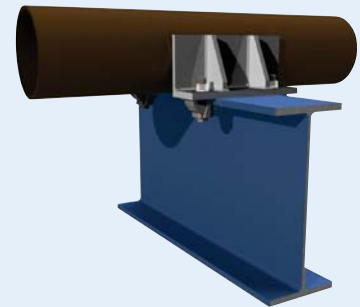

Grate-Fast steel floor connections were used for the installation of open bar grating platforms to provide maintenance access to accent lighting equipment on Philadelphia's Benjamin Franklin Bridge. The Grate-Fast connections allowed the platforms to be installed by a single person using standard hand tools.

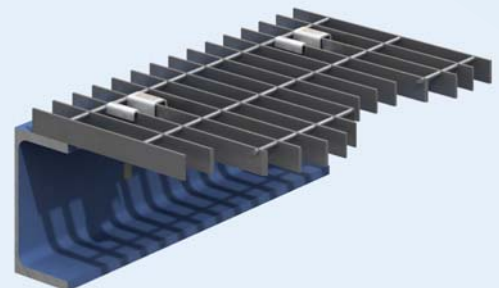



General Inquiries:
inquiries@LindapterUSA.com

Technical Inquiries:
support@LindapterUSA.com

Website:
www.LindapterUSA.com

Edge Construction Supply



Authorized Lindapter Distributor

<p>1</p> <p>Spokane, WA</p> <p>1503 East Riverside Ave. Phone: (800) 348-4808 or (509) 535-9841 Fax: (509) 534-3139</p>	<p>2</p> <p>Yakima, WA</p> <p>812 East Mead Ave. Phone: (800) 243-5582 or (509) 248-1144 Fax: (509) 575-4696</p>	<p>3</p> <p>Boise, ID</p> <p>2000 Century Way Phone: (800) 528-5118 or (208) 377-0158 Fax: (208) 377-0978</p>
<p>4</p> <p>Eugene, OR</p> <p>490 S. Bertelsen Phone: (800) 944-0165 or (541) 342-3641 Fax: (541) 343-1753</p>	<p>5</p> <p>Medford, OR</p> <p>1789 Sage Road Phone: (800) 871-3919 or (541) 779-0187 Fax: (541) 773-4599</p>	<p>6</p> <p>Idaho Falls, ID</p> <p>760 West Broadway Phone: (208) 522-7082 Fax: (208) 529-5456</p>
<p>7</p> <p>Billings, MT</p> <p>120 Moore Lane Phone: (800) 272-7196 or (406) 248-7196 Fax: (406) 248-7269</p>	<p>8</p> <p>Gillette, WY</p> <p>105 Warren Avenue Phone: (800) 670-6851 or (307) 682-8522 Fax: (307) 682-8576</p>	<p>Find your nearest Lindapter stocking distributor above...</p> <p>For more details visit: www.edgecs.com</p>