



Construction Supply

www.edgecs.com

Product Catalog № 11

*Serving the
Construction Industry
Since 1949*

Spokane

Billings

Boise

Idaho Falls

Eugene

Gillette

Medford

Yakima



UNISTRUT®

A PART OF **atkore**
INTERNATIONAL



There is only one Unistrut Metal Framing System. Take advantage of the most complete and flexible support system available, by contacting our national network of distributors and service centers. See for yourself how to work faster, easier, and smarter with the one and only framing system.



***Solutions available
24 hours a day at
www.unistrut.com***

UNISTRUT®

The one you know,
the one you trust,
the one you ask for
by name.



***NEW
Product Catalog!
Order online at
www.unistrut.com***

- ◆ Complete technical data section
- ◆ Downloadable CAD drawings for all components
- ◆ Advanced search functions & cross-referencing capabilities
- ◆ Extensive literature library
- ◆ Ability to generate submittals personalized for your clients

800-348-4808

www.unistrut.com

To Our Valued Customers:

Edge Construction Supply is proud to present our new product catalog. This catalog is the culmination of over 60 years of being in business and servicing the construction and industrial markets. It's hard to believe we started back in 1949 as a scaffolding company in Spokane, Washington under the name of Safway Supply. In 2007, we sold our scaffold division and changed our name to Edge Construction Supply. While the name changed, the large majority of our business has remained the same and we continue to be privately held. Over the years we've grown to become a dominant regional distributor with eight locations across the five northwest states of Washington, Oregon, Idaho, Montana, and Wyoming.

We have built our reputation by providing the best selection of high quality tools and supplies from the industry's leading manufacturers. Edge prides itself on stocking large inventories of tools and supplies that our customers have come to expect and need to satisfy tight schedules and large projects. We offer over 60,000 items that we buy direct from over 300 manufacturers. Inside this newest catalog you will find over 600 pages of our most popular products. We want you to use this catalog as a buying guide and reference tool to assist in your purchasing needs.

Our highly trained sales staff knows the construction business and is eager to help you with your project and make sure you get the right tool or product for the job. If you do not see an item you are looking for, give us a call and our experienced staff can locate most any product and provide you with a solution. We pride ourselves on being the best problem solvers in the industry. We have the flexibility to quickly order or stock specialty tools, supplies, and engineered products to meet all your construction and manufacturing needs. This catalog is primarily a reference tool and only provides a summary of the most important product features, so contact our staff for help in putting together submittal packages and gathering the most up-to-the-date manufacturer's specifications to fulfill any detailed requirements you have.

Thank you for over 60 years of business and trust that you have placed in us. We value our relationship and look forward to many more years of serving you. We will continue to work hard to make Edge Construction Supply your supplier of choice and one-stop-shop!

Sincerely,

Eric Grabowski

Eric Grabowski
President

Rick Thomas

Rick Thomas
Chairman

So, come to the Edge, and let us be your supplier of choice and integral business partner.

Edge Customer Service Policies

Pricing & Quotations

Prices have been omitted from this catalog because of frequent changes by manufacturers. However, as a customer you may be fully confident that our prices will be competitive with current market quotations. Prices are typically net distribution prices and are subject to change without notification. Quotations are available upon request. Quotations are good for immediate acceptance unless otherwise noted, and are subject to change without notice.

Sales Tax

Edge is required to charge state and local tax for which sales tax exemption certification has not been provided. Please provide sales tax exemption certification before ordering.

Terms of Sale

For customers with established credit, payment terms are Net 30. All orders are subject to the approval of the Credit Department. Payments should be mailed to the remit to address on the invoice. A service charge will be added to all amounts not paid within 30 days.

Cash Payment

We accept cash and most major credit cards.

Returns & Cancellations

We desire to handle all returns in a fair and flexible manner. Please contact a customer service representative prior to returning any merchandise for approval. Edge requires original invoice on all returned merchandise and will charge a restocking fee or handling charge. Special order or custom manufactured items may not be returned or cancelled. Products with an expiration date may not be returned if close to or after the expiration date. Products with traceability or certification requirements may not be returned without all necessary documentation. Products with damaged boxes and missing proper identification may not be returned. Cancellation of orders may not be made without our consent.

Delivery & Freight

We offer flexible freight and delivery options. Ask about the most effective way to get your products to your jobsite or location in the timeframe you require. We have delivery vehicles to service local delivery needs. Edge also contracts with UPS, common carriers, and flatbed haulers to provide freight options for all the products we carry to any location requested. Special delivery requests, direct shipments from the manufacturer, UPS and common carrier from our warehouse are F.O.B. shipping point unless otherwise noted. All merchandise becomes the property of the purchaser upon delivery to the carrier. In the event merchandise is damaged or lost in transit, claims should be submitted to the carrier.

Warranty

Products in this catalog are warranted to the final consumer by the manufacturer. Each manufacturer's or product's warranty is specific and unique. Copies of such warranties are either supplied with product, are available from the manufacturer, or can be requested.

Responsibility

It is our policy to represent only top line manufacturers who supply quality merchandise. Nevertheless, some products may occasionally prove to be defective. Our liability is limited to the value of the defective material. We will not allow claims for consequential damages, labor or other expenses.

Specifications

Edge has made a diligent effort to illustrate and describe the products in this catalog accurately. However, the product data and specifications are for reference only. Descriptions and specifications are subject to change at any point in time. If you require manufacturer's specifications for a product or for a submittal, contact Edge. Edge is happy to provide manufacturer's specifications for submittals. We assume no responsibility for descriptions and specifications as a result of this reprint.

OVER 60 YEARS OF SERVICE TO CONSTRUCTION AND INDUSTRY!

Branch Locations



SPOKANE, WA

1503 E. Riverside Ave.
Spokane, WA 99202
Phone: (800) 348-4808 or (509) 535-9841
Fax: (509) 534-3139
Hours: 7:00 AM - 5:00 PM, Monday to Friday

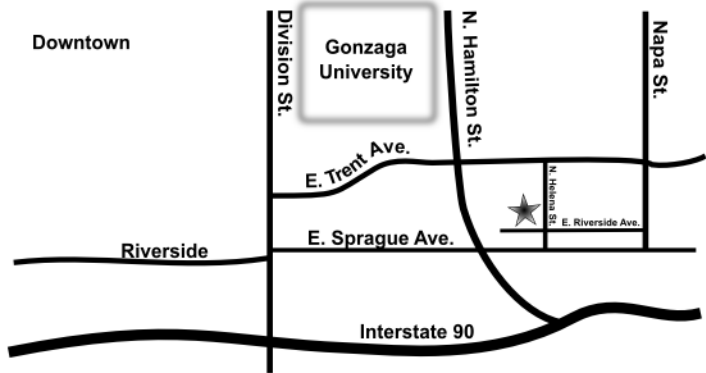

YAKIMA, WA

812 E. Mead Ave.
Yakima, WA 98903
Phone: (800) 243-5582 or (509) 248-1144
Fax: (509) 575-4696
Hours: 7:00 AM - 5:00 PM, Monday to Friday

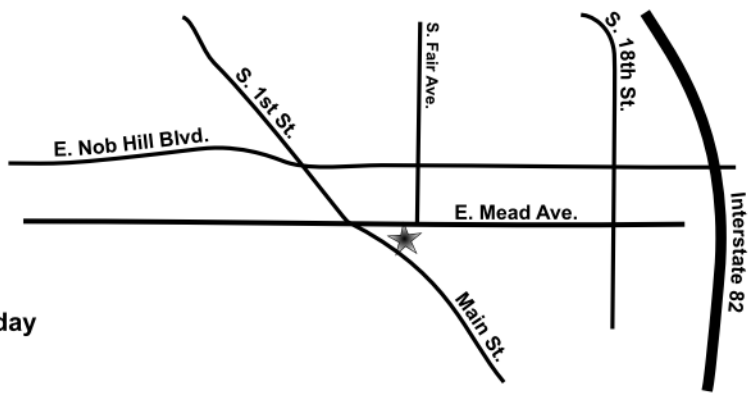

GILLETTE, WY

105 Warren Ave.
Gillette, WY 82716
Phone: (800) 670-6851 or (307) 682-8522
Fax: (307) 682-8576
Hours: 7:30 AM - 5:00 PM, Monday to Friday

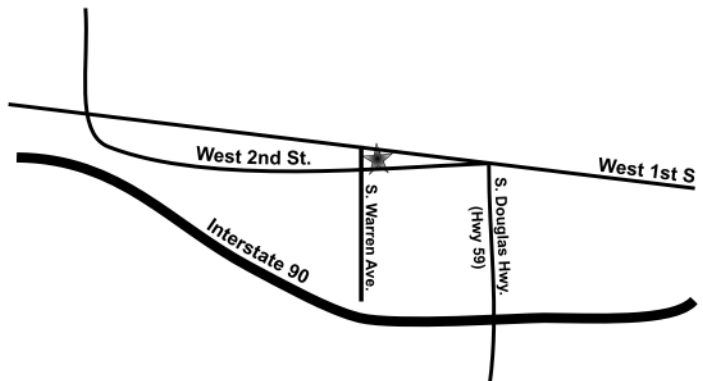

BILLINGS, MT

120 Moore Ln.
Billings, MT 59101
Phone: (800) 272-7196 or (406) 248-7196
Fax: (406) 248-7269
Hours: 7:30 AM - 5:00 PM, Monday to Friday

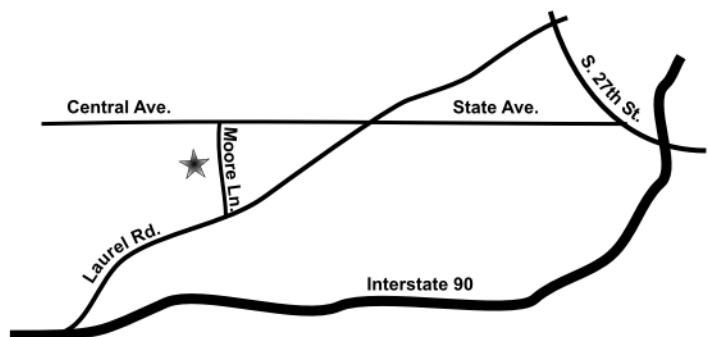



Branch Locations

EUGENE, OR

490 S. Bertelsen
 Eugene, OR 97402
 Phone: (800) 944-0165 or (541) 342-3641
 Fax: (541) 343-1753
 Hours: 7:00 AM - 5:00 PM, Monday to Friday

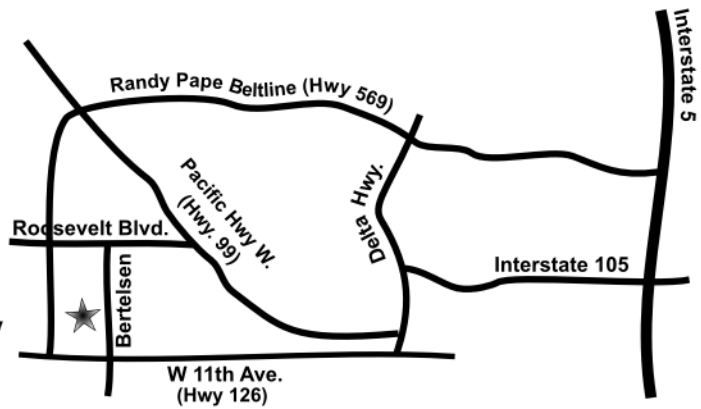

MEDFORD, OR

1789 Sage Rd.
 Medford, OR 97501
 Phone: (800) 871-3919 or (541) 779-0187
 Fax: (541) 773-4599
 Hours: 7:00 AM - 5:00 PM, Monday to Friday

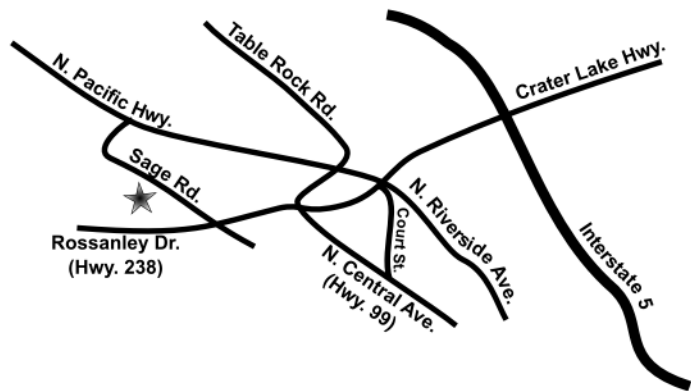

BOISE, ID

2000 Century Way
 Boise, ID 83709
 Phone: (800) 528-5118 or (208) 377-0158
 Fax: (208) 377-0978
 Hours: 7:00 AM - 5:00 PM, Monday to Friday

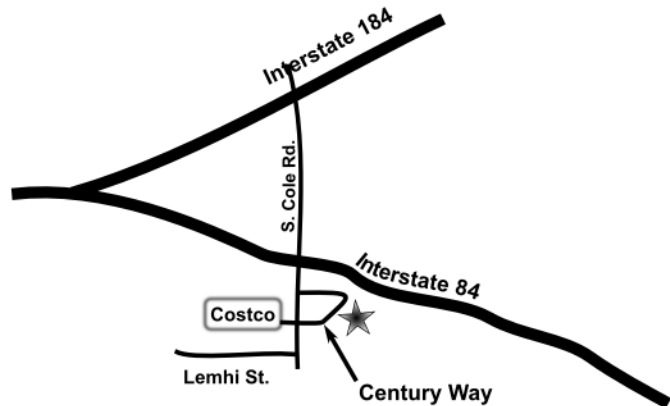

IDAHO FALLS, ID

760 West Broadway
 Idaho Falls, ID 83402
 Phone: (208) 522-7082
 Fax: (208) 529-5456
 Hours: 7:00 AM - 5:00 PM, Monday to Friday

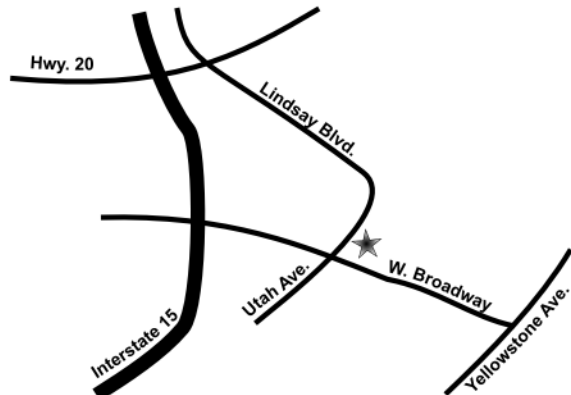

Table of Contents



COME TO THE EDGE FOR ALL YOUR SUPPLY NEEDS

Rental, Repair, Engineered Systems, Services

Power Tools & Accessories

Mechanical & Electrical Work Equipment

Access Equipment, Material Handling, & Storage

Hand Tools

Safety, Jobsite Protection, & Clothing

Airtools & Construction/ Heavy Industrial Equipment

Concrete Tools & Supplies

Lasers, Marking, & Measuring

Lighting & Power Distribution

Strut, Hangers, & Fittings

Anchors & Fastener Systems

Abrasives

Firestop, Caulk, Paint, & Chemicals

Telespar & Signposts

General Construction & Maintenance Supplies

Index

Miscellaneous Information

Edge Construction is a proud member of the *Evergreen Supply Network*

We work with the best, so you get the best.

A NETWORK OF SELECT CONSTRUCTION & INDUSTRIAL SUPPLY DISTRIBUTORS & LEADING MANUFACTURERS

We are proud to be members of The Evergreen Supply Network. Evergreen is a group of focused industrial and construction distributors serving the United States and Canada that provides you with

- Leading products
- Competitive prices
- Cutting edge product & application knowledge
- Superior customer service
- Highly trained sales professionals

Founded in 1989, Evergreen is a select partnership of leading distributors and manufacturers located across North America. Today, Evergreen is a fast-growing network of more than 70 distributors with 260 locations and 90 manufacturers.

Together, Evergreen distributors generate annual revenues of more than \$1 billion, stock hundreds of millions of dollars of inventory and consistently achieve above average growth. Collectively, Evergreen members have more than 1,300 highly trained sales people able to serve as product and application consultants. Evergreen manufacturers are among the nation's premier-brand industrial manufacturers.

Not every distributor or manufacturer is invited to be part of Evergreen. Rather, Evergreen looks for leaders in each market or product category and then helps them work together to provide industrial buyers and contractors with a higher level of service and support. As a result, Evergreen members work together to satisfy the requirements of contractors and industrial buyers locally, regionally and nationally. If you are looking for the scope and reach of a national organization but with the service and support of an independent locally owned and operated supplier dedicated to the markets they serve, look no further than a member of the Evergreen Supply Network. Evergreen is focused on providing its distributor

members with training programs that are unmatched in the industry. Evergreen leverages the resources of the group to provide several levels of product and application training that are simply not available to other distributors. As a result, when you do business with an Evergreen member, you are working with the industry's best-trained, most knowledgeable professionals. Dealing with seasoned, application-savvy individuals saves you time, increases your productivity and helps you make intelligent product decision.

Evergreen invests more than \$1 million each year in training and education for our distributor members.

We maintain an 11,000-square-foot training center in the Dallas/Ft.

Worth area and conduct 20 or more classes each year, including product & application training and best business practice seminars. Evergreen developed these programs because people in construction and industry prefer to do business with informed and educated professionals.

When you work with a member of the Evergreen Supply Network, you are working with a business that is committed to providing you with

- High-quality, name-brand products
- Exceptional customer service and value-added support
- In-depth product and application knowledge

Evergreen members have invested for the long-run in their people and their ability to serve you by joining the Evergreen Network.

Distributors who are a part of Evergreen offer you more than just tools and supplies. They offer you a relationship with a network of the finest construction and industrial distributors and manufacturers across North America.





STAFDA

The Specialty Tools and Fasteners Distributors Association (STAFDA) is an educational trade association to encourage legal, ethical, and friendly business relations and to maintain and enhance competition within the industry.



AGC

The Associated General Contractors of America (AGC) was established in 1918 and is the nation's largest and oldest construction trade association. It is an organization of qualified construction contractors and industry related companies dedicated to skill, integrity, and responsibility. The association provides a full range of services satisfying the needs and concerns of its members, thereby improving the quality of construction and protecting the public interest.



ABC

The Associated Builders and Contractors (ABC) was founded in 1950 to create an association based on the shared belief that construction projects should be awarded on merit to the most qualified and responsible low bidders. It is now a national association representing all specialties within the U.S. construction industry and is comprised primarily of firms that perform work in the industrial and commercial sectors of the industry.



NAWIC

The National Association of Women in Construction (NAWIC) originally began as Women in Construction of Fort Worth, Texas. It was founded in 1953 by 16 women working in the construction industry. Knowing that women represented only a small fraction of the construction industry, the founders organized NAWIC to create a support network. Women in Construction of Fort Worth was so successful that it gained its national charter in 1955 and became the National Association of Women in Construction.



Rental Service

From scissor lifts to fastening, baker scaffolding to span planks, and breaking concrete to woodworking, our rental department really does "**rent what we sell.**" We also help you identify what tools work best for your specific job in your unique environment.

Rental Policies

• Rate Structure

1 day = 8 hours

1 week = 5 days

1 month = 4 weeks

• **Billing** occurs either every 28 days or upon return of equipment

• **Delivery** charges vary based on type of equipment, length of rental, and travel distance



Some Reasons our Customers Rent

- Conservation of **Capital**: Renting frees capital for a contractor or company. Capital can potentially be used for more profitable business.
- Warehousing & **Maintenance**: Rental equipment does not require long-term warehouse space or maintenance. Renting allows contractors to operate with less overhead.
- Correct **Equipment** for the job: Ownership of equipment can cause inefficiency by using the wrong type or size of equipment for any given job. Renting ensures the right equipment for the job. Additionally, customers don't have obsolete equipment in their inventory if they rent.
- **Cost Control**: It is easier to control cost when you rent equipment. Knowing the true cost of owned equipment is difficult. Rented equipment offers one accountable cost figure that is shown on the rental invoice.



-- Call for Specific Brands, Sizes, and Availability --



**Bending
Equipment**



**Pulling
Equipment**



**Threading
Equipment**

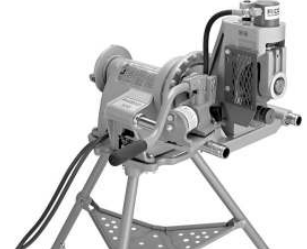

**Grooving
Equipment**



**Lifting and
Hauling**



Chain Hoists



**Hilman
Rollers**



Core Drills



**Concrete
Cutting**



Compactors



**Rotary
Hammers**



**Powder and
Gas Tools**



Pump Jacks



**Utility
Scaffold**



Planks



Scissor Lifts

Don't see what you are looking for? Then give us a call.

-- Call for Specific Brands, Sizes, and Availability --



Pneumatic Tools



Compressors



Generators



Power Distribution



Heaters



Hydraulic Rams/Pumps



Air Tools and Breakers



Blowers and Fans



Confined Space Equip.



Gas Monitors



Lasers



Power Tools



Ladders



Mag Drills



Tow Behind Compressors



Trash Pumps

Don't see what you are looking for? Then give us a call.



Repair and Service

Our technicians service virtually all makes of equipment. We accomplish quick turnaround and efficient tracking of our customer's tool repairs from start to finish. We repair, stock, and service parts from our extensive tool and equipment inventory. We are a factory warranty station for most vendors below.

AIRMAN COMPRESSORS	GREENLEE FAIRMONT	PASLODE
ATLAS COPCO	GUARDIAN	PLS LASERS
BIO-SYSTEMS	HITACHI	PNEUTEK
BLACK & DECKER	HOMELITE GENERATORS	PIONJAR GAS DRILLS
BOMAG	HOUGEN	PORTER CABLE
BOSCH	HUSQVARNA	POWERS/RAWL
BURNDY	INGERSOLL RAND	RAMSET
CEP ELECTRICAL	ITW BUILDEX	REED
CHICAGO PNEUMATIC	JENNY COMPRESSORS	RIDGID
CM HOIST	JET	ROLAIR
COLEMAN CABLE	KETT	ROTHENBERGER
CST BERGER	LUG-ALL	SUMNER
CURRENT	LUMIDOR	SHOP VAC
DBI/SALA	M.K. MORSE	SIMPLEX HYDRAULICS
DEWALT	MAKITA	SKIL
DIAMOND PRODUCTS	MARSON	SKYCLIMBER
DIMAS	MASTER HEATERS	SIMPSON QUICKDRIVE
DUOFAST	MBW	SIOUX
EDCO	METABO	STOW
EMGLO	MILLER FALL PROTECTION	TARGET
ENERPAC	MILWAUKEE TOOL	UPRIGHT
FEIN	MOTOROLA RADIO	UNIVERSAL HEATERS
GARDNER BENDER	MULTIQUIP	WEKA/CORE DRILLS
GENIE	NITTO-KOHKI	WHEELER REX
GOLO	OZTEC	WOBBLE LIGHT
GREENLEE	PARTNER	YAMAHA GENERATORS

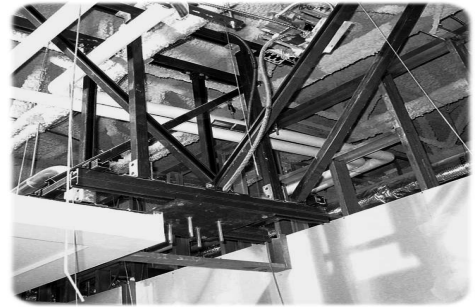

Medical Equipment Mounts

- X-ray equipment support systems
- Flexible patient lift support
- Rigid surgical boom supports
- Universal grids available for future expansion
- Variety of options for surgical light supports
- Adjustable telespar drops available
- Designs can include seismic requirements based on local jurisdiction

Laboratory Supports and Shelving

- Laboratory shelving, overhead supports, island shelving, . . .
- Providing custom powder coated Unistrut for laboratory applications
- Providing custom sheet metal parts to match Unistrut
- Ask about overhead supports and equipment suspended from ceiling structures for lab use
- Uses include high schools, colleges, biomed, medical, . . .



Architectural Grids



- Foyers, hallways, lobbies, lecture halls, art rooms, waiting areas, convention centers, . . .
- Custom colors and finishes available
- Can double as structural support for conduit, acoustic panels, plumbing, cable trays, . . .
- Can attach to virtually any overhead structure including a sloped structure
- Can design grid with slope and different elevations

Overhead Support Grid

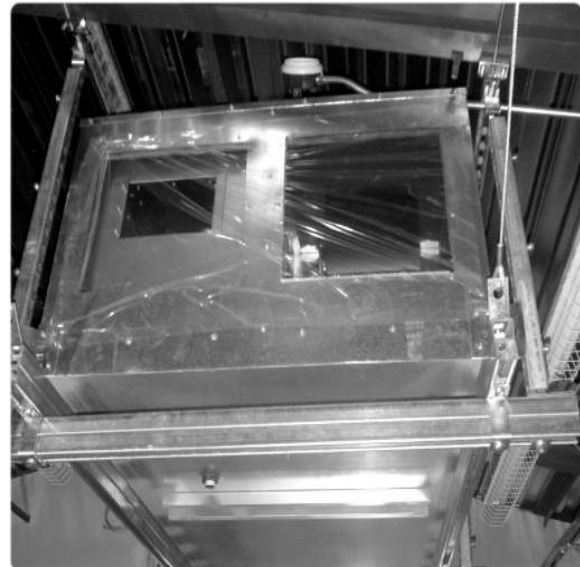

- Used to festoon tools, hang art, hang department store signage, for school shop equipment, assembly cells, electrical data services, . . .
- Unistrut frames can be used on roof tops as wind blocks and to hide equipment
- Seismic bracing also available



Walkways and Platforms



- Rooftop non-skid, grated walkways
- Overhead, suspended catwalks
- Work platforms surrounding rooftop equipment
- Custom guardrails using Unistrut framing

Other Applications and Engineered Systems

- Call today to speak to an expert about your application and see how Edge can solve your problem
- Engineered Permanent Fall Protection Systems
 - Rooftop fall protection lines and anchors
 - Ladder fall protection systems
 - Industrial applications
- Aluminum Railings
 - Flexible designs with ability to modify existing designs
 - Finishes: Mill, anodized, or powder coated
 - Highly corrosive-resistant
 - No welding required
- Solar Panel Framing
 - Call for engineering or material quotes





Right products for the right job

- Ask about options for having an on-site warehouse to fulfill your job or manufacturing material needs.
- Edge can work with you to provide materials, consumables, tools, and other items available for your project both when you need it and where you need it. You don't have to spend valuable time traveling to your local Edge store when it's conveniently located in your facility or project. This can be especially valuable for remote job-sites and hard-to-access locations.
- Different than a keep-fill system, Edge's NOS Box program is typically jointly managed between the customer and a sales representative. This has two benefits: to keep the costs reasonable and to make sure you have the right products during the right phases of your project.

Customization for your company

- **Size of Box/Container:** Box sizes can vary from a small jobsite box to a large conex. Edge can even place one box per floor if the job is large enough to warrant it.
- **Inventory Type & Amount:** We work with you to get it right. Ask about recommending trade specific products for mechanical, plumbing, electrical, and other work. Typical items include Unistrut fittings, fasteners, anchors, spring clips, abrasives, carbide bits, saw blades, safety items, . . .
- **Billing:** Negotiated whether the inventory is purchased up-front or consigned. Invoicing will occur either every time new product is added or monthly.
- **Management:** Typically the customer will designate one responsible person for keeping control of the inventory. This person would have a key to the lock and be readily available to open or close the box.

Flexibility toward your needs

- Flexibility is key with the NOS Box program. While many customers utilize a clam-shell style box with common consumable items, you might well have different needs. Edge is always open to discussing your needs and providing a solution that works for your specific requirements.





18V Hammerdrill/Drill/Driver

1/2" Li-Ion
DeWalt



- DeWalt® 18V XRP Li-Ion Batteries offer long battery life & durability
- Patented 3-speed all-metal transmission
- LED worklight provides increased visibility in confined spaces

Includes: Drill, (2) XRP Li-Ion batteries

- 450 unit watts of power
- Max RPM: 1200

Item #

DTDCD970KL

18V Cordless Drill/Driver Kit

1/2"
DeWalt



Specifications:

- Voltage: 18 V
- 450 unit watts of power
- Max RPM: 0-500/0-1,200/0-2,000
- Clutch Settings: 22
- Chuck Size: 1/2"
- Includes: 1 hour charger, (2) 18V XRP™ batteries, 360° side handle kit box

Item #

DTDCD940KX

18V Cordless Hammerdrill/Drill/Driver Kit

1/2"
DeWalt



- Voltage: 18 V
- 450 unit watts of power
- Max RPM: 0-500/0-1,200/0-2,000
- Max BPM: 0-8,500/0-21,250/0-34,000
- Includes: drill, (2) XRP Nicad batteries, case

Item #

DTDCD950KX

18V Cordless

1/2" Compact Drill
DeWalt



- Compact size: Allows users to fit into tight spaces
- Lightweight design (4.8 lbs.) minimizes user fatigue
- 1/2" single sleeve ratcheting chuck reduces bit slippage
- Dual speed range 0-500/0-1,700 rpm delivers optimal performance
- High performance frameless motor delivers maximum power of 410 unit watts out
- LED work light provides increased visibility in confined spaces
- Voltage: 18 V
- Max Power: 410 UWO
- # of Speed Settings: 2
- Max RPM: 1,700
- Clutch Settings: 17; Chuck Size: 1/2 "
- Chuck Type: plastic, single sleeve
- Includes: 1 hour charger, (2) 18V batteries, screwdriver bit, heavy-duty kit box

Item #

DTDC720KA

18V Cordless XRP Li-Ion Drill/Driver Kit

1/2"



- XRP™ Li-Ion extended run-time batteries provide superior ergonomics, long run-time & battery life
- Patented 3-speed all-metal transmission matches the tool to task for fastest application speed and improved run time
- Heavy-Duty 1/2" metal ratcheting chuck helps prevent bits from slipping and falling out
- LED Worklight provides increased visibility in confined spaces
- High power, high efficiency motor delivers 450 unit watts out of max power for superior performance in all drilling and fastening applications
- Best in class length improved balance and better control
- Includes: 1 hour charger, (2) 18V XRP™ Li-Ion batteries, 360° side handle, kit box

Item #	Max Power	Max RPM	Clutch Settings	Tool Wt. (lbs.)
DTDCD960KL	450UWO	0-500/0-1250/ 0-2000	22	5.25

18V Compact Drill/Driver Kit

1/2" Li-Ion
DeWalt



- Dual speed range 0-500/0-1700 rpm
- Lightweight design (4.0 lbs.); LED worklight
- Includes: Drill, (2) 18v Li-Ion batteries, Charger, handle, case

Item #

DTDCD760KL



18V Cordless Drywall/Deck Screwdriver Kit

DeWalt



- Dual speed ranges (0-900/0-2,900 rpm); high speed for drywall, low speed for decking
- Depth-sensitive, "set and forget" nose-piece for consistent fastener depth

Specifications:

- Capacity (CRS): 12 ga.
- Drive Size: 1/4" Hex in.
- Includes: Screwgun, 1 hour charger, (2) 18V XRP™ batteries, bit tip magnetic holder, drywall nosepiece, TEKS® nosepiece, kit box

Item #

DTDC520KA

18V Cordless Framing Screwdriver Kit

DeWalt



- Versa-Clutch® torque adjustment system "dials in" the proper torque needed to efficiently drive fasteners without stripping or breaking fastener

Specifications:

- No Load Speed: 0-900/0-2,700 rpm
- Capacity (CRS): 12-28 ga.
- Drive Size: 1/4" Hex in.
- Includes: 1 hour charger, (2) 18V XRP™ batteries, #2 Phillips screwdriver bit, 5/16" nut runner, kit box

Item #

DTDC668KA

18V Cordless Impact Wrench Kit

1/2"



- 300 ft-lbs of maximum torque
- 1,650 rpm/2,600 ipm
- Preferred rocker switch design for fast and easy forward and reverse
- Durable magnesium gear case and all-metal transmission for extended durability
- Includes: Impact wrench, (2) 18v Nicad batteries, charger, case

Item #

DTDW059K-2

18V Cordless Impact Wrench Kit

1/2"

DeWalt



- No Load Speed: 0-2,400 rpm
- Impacts/Min: 0-2,700 bpm
- Compact size & weight allow access into tighter areas and reduces user fatigue
- Durable magnesium gear case and all metal transmission
- Heavy-duty impacting mechanism directs torque
- Drive Size: 1/2" square with detent pin retention in
- Includes: Impact, 1 hour charger, (2) 18V XRP™ batteries, heavy-duty kit box

Item #

DTDC820KA

18V Impact Driver Kit

1/4"

DeWalt



- Drive Size: 1/4" hex shank quick release in
- No Load Speed: 0-2,400 rpm
- Impacts/Min: 0-2,700 bpm
- Includes: 1 hour charger, (2) 18V XRP™ batteries, heavy-duty kit box

Item #

DTDC825KA

18V Cordless 1/4" Impact Driver Kit

1/4" Li-Ion

DeWalt



- 0-2,400 rpm/0-2,700 ipm
- Heavy-duty impacting mechanism directs torque to fastener without kickback
- DeWalt® exclusive NANO™-phosphate lithium ion cells offer long battery life & durability
- Drive Size: 1/4" hex shank quick release in
- Includes: Impact, 1 hour charger, (2) 18V batteries with Nano™ technology, heavy-duty kit box

Item #

DTDC827KL



18V Cordless Right Angle Grinder

3/8"
DeWalt



- 2 speed ranges 0-500/0-1,500 rpm for increased user flexibility providing a wide range of applications
- Multi-grip trigger
- Variable speed and reversing

Specifications:

- Chuck Size: 3/8"; RPM: 0-500/0-1,500
- Includes: Drill, 1 hour charger, (2) 18V batteries, kit box

Item #

DTDW960K-2

18V Cordless SDS Rotary Hammer Kit

1"
DeWalt



- Shocks™ - Active Vibration Control reduces vibration up to 70%, increasing user comfort and productivity
- Compact L-shape design allows access in tight spaces, while providing optimal balance for the user

Specifications:

- Concrete Optimum: 5/32"-1/2"
- No Load Speed: 0-1,100 rpm; Beats/Min: 0-4,100 bpm
- 1.7 ft/lb impact energy
- Includes: Rotohammer, 1 hour charger, (2) 18V XRP™ batteries, 360° side handle, depth rod, kit box

Item #

DTDC212KA

18V Cordless SDS Rotary Hammer Kit

7/8", Li-Ion



- Shocks™ - Active Vibration Control significantly reduces vibration and increases user comfort and productivity
- Compact L-shape design
- Variable speed, reversing switch delivers versatility in all applications
- Factory-set clutch reduces sudden, high torque reactions if bit jams
- 360° side handle for better control and ease of use in tight spaces
- 1.7 ft/lb impact energy
- Includes: Rotohammer, (2) 18V Li-Ion batteries, charger, handle, case

Item #

DTDC212KL

18V Cordless Reciprocating Saw Kit

1-1/8" Stroke
DeWalt



- 1-1/8" stroke length for faster cutting speed
- 0-3,000 spm for faster cutting speed
- 4-position blade clamp
- Keyless lever-action blade clamp

Specifications:

- Strokes/Min: 0,3000 spm
- Includes: Saw, 1 hour charger, 18V XRP™ battery, kit box

Item #

DTDC385K

18V Cordless Speed Jig Saw Kit

w/Keyless Blade Change
DeWalt



- Keyless lever-action blade clamp for quick and easy blade changes
- 4 position orbital action provides control of aggressiveness of cut and speed

Specifications:

- Strokes/Min: 0-3,000 spm
- Stroke Length: 1"
- Dust Blower: Yes
- Includes: Jigsaw, 1 hour charger, 18V XRP™ battery, jig saw blades, kit box

Item #

DTDC330K

18V Cordless Pencil Vibrator Kit

DeWalt



- 1-1/8" diameter vibrator delivers maximum consolidation power
- 4 foot long flexible shaft for easy use and long reach

Specifications:

- Vibrator Size: 1-1/8"
- Vibrations Per Minute: 14,000 VPM
- Includes: Vibrator, 1 hour charger, (2) 18V XRP™ batteries, soft-side bag for batteries and charger

Item #

DTDC530KA



18V Swivel Head Shear Kit

18 Gauge
DeWalt



- Head swivels 360°
 - Cuts 7/32" strip which continuously curls out of the cutting area
- Specifications:
- Strokes/Min: 0-2,300 spm
 - Minimum Cutting Radius: 5.5"
 - Capacity In Steel: 18-28 ga.
 - Includes: Shear, 1 hour charger, (2) 18V XRP™ batteries, blade wrench, kit box

Item #
DTDC490KA

18V Cordless Adhesive Dispenser

- 360° rotateable cartridge holder fits
- Tool delivers up to 650 pounds pushing force
- Auto-reverse feature helps reduce drips, waste, and clean-up
- Set-and-Forget variable speed control for consistent flow rates and bead control



Specifications:

- Max Speed: 25 in/min
- Includes: Gun, 18V battery, 1 hour charger

Item #	Cap.
DTDC545K	10 oz, 1/10 gal, & 300 ml-310 ml cartridges
DTDC546K	29 oz, & quart size cartridges

18V Cordless Adhesive Dispenser DeWalt



- 360° rotateable cartridge holder fits 300 ml and 600 ml sausage pak
- Tool delivers up to 650 pounds pushing force
- Auto-reverse feature helps reduce drips, waste, and clean-up
- Set-and-Forget variable speed control for consistent flow rates and bead control

Specifications:

- Max Speed: 25 in/min
- Includes: Gun, 18V battery, 1 hour charger

Item #
DTDC547K

18V Cordless 6-Tool Combo Kit

XRP™



- DCD950 18V XRP™ cordless hammerdrill
- DC390 18V circular saw with 6-1/2" carbide blade
- DC385 18V cordless reciprocating saw with keyless blade clamp
- DC825 18V impact driver with 1,330 in-lbs of maximum torque
- DC411 18V cut-off tool with 6,500 rpm
- DW919 18V flexible floodlight
- 450 unit watts of power
- Includes: (2) 18V XRP™ batteries, 1 hour charger, 360° side handle, carbide tipped blade, type 1 guard and wheel, wrench, backing flange, 2-position side handle, contractor bag

Item #
DTDCK655X

18V Cordless 6-Tool Combo Kit

XRP™ Li-Ion



Kit Contains:

- DCD970 18V XRP™ cordless hammerdrill
- DC827 18V impact driver delivers 1,330 in-lbs of torque and 0-2,400 rpm
- DC385 18V reciprocating saw with 4-position keyless blade clamp
- DC411 18V cut-off tool with 6,500 rpm
- DW059 18V 1/2" high torque impact wrench with 300 ft-lbs of maximum torque
- DW919 18V flexible floodlight
- 450 unit watts of power
- Includes: (2) 18V XRP batteries, charger, handle, carbide tipped blade, bag

Item #
DTDCK675L

18V Cordless 4-Tool Combo Kit

XRP™



Kit Contains:

- DCD950 18V XRP™ cordless hammerdrill
- DC390 18V circular saw with 6-1/2" carbide blade
- DC385 18V cordless reciprocating saw with keyless blade clamp
- DW919 18V flexible floodlight
- 450 unit watts of power
- Includes: (2) 18V XRP batteries, charger, carbide tipped blade, case

Item #
DTDCK450X



18V Cordless 4 Tool Combo Kit

XRP™



Kit Contains:

- DCD950 18V XRP™ cordless hammerdrill
- DC825 18V Impact Driver delivers 1,330 in-lbs of torque and 0-2,400 rpm
- DC385 18V reciprocating saw with 4-position keyless blade clamp
- DW919 18V flexible floodlight
- 450 unit watts of power
- Includes: (2) 18v Nicad batteries, charger, bag

Item #

DTDCK455X

18V 4 Tool Combo Kit

XRP™ Li-Ion



Kit Contains:

- DCD970 18V XRP™ cordless hammerdrill
- DC827 18V impact driver delivers 1,330 in-lbs of torque and 0-2,400 rpm
- DC385 18V reciprocating saw with 4-position keyless blade clamp
- DW919 18V flexible floodlight
- 450 unit watts of power
- Includes: (2) 18v Li-Ion batteries, charger, bag

Item #

DTDCK475L

18V Hammerdrill/Reciprocating Saw Combo Kit

XRP™



Kit Contains:

- DCD950 18V XRP™ cordless hammerdrill
- DC385 18V cordless reciprocating saw with keyless blade clamp
- 450 unit watts of power
- Includes: (2) 18v XRP Nicad batteries, charger, bag

Item #

DTDCK251X

18V Hammerdrill/Impact Driver Combo Kit

XRP™ Li-Ion



Kit Contains:

- DCD970 18V XRP™ cordless hammerdrill
- DC827 18V impact driver delivers 1,330 in-lbs of torque and 0-2,400 rpm
- 450 unit watts of power
- Includes: (2) 18v Nicad batteries, charger, bag

Item #

DTDCK275L

18V Cordless Hammerdrill/Impact Driver Combo Kit

XRP™



Kit Contains:

- DCD950 18V XRP™ cordless hammerdrill
- DC825 18V impact driver delivers 1,330 in-lbs of torque and 0-2,400 rpm
- 450 unit watts of power
- Includes: (2) 18v Nicad batteries, charger, bag

Item #

DTDCK255X

18V Cordless

Flexible Floodlights
DeWalt



- Wide-angle beam is brighter than traditional flashlights
- Flexible neck allows for hands-free operation and light to be projected in any direction whether it is standing on its base, wrapped around a pipe, or hanging from rafters overhead

Specifications:

- Bulb: Xenon
- Brightness: 325 Lumens
- Bulb Life: 110 hrs.
- Run-Time: 3 hrs.

Item #

DTDW919

18V Battery Pack - Li-Ion

DeWalt



- Compatible with DeWalt® 18 Volt tools
- DeWalt® exclusive Nano™-phosphate lithium ion cells offer long battery life & durability: 2,000 recharges
- Compatible with Entire line of DeWalt® 18 Volt tools

Item #

DTDC9180



18 Volt Compact Battery Pack

DeWalt

- High capacity XRP™ battery has 40% more run-time than standard batteries
- Powers entire DeWalt® line of 18V tools allowing users to run multiple tools off of the same battery pack



Specifications:

- Compatible with: Entire line of DeWalt® 18 Volt tools

Item #

DTDC9096

Cordless Wet/Dry Portable Vacuum

12V-18V

DeWalt



Specifications:

- Tank Size: 2 gal.
- Hose diameter: 1-1/4"
- Hose length: 5'
- Voltage (DC Operation): 12-18V
- Blower
- Includes 5' heavy-duty rubber hose, crevice tool and wide nozzle

Item #

DTDC500

1 Hour Battery Charger

7.2V-18V NiCd/NiMH/Li-Ion

DeWalt

- Charges all DeWalt® 7.2V - 18V NiCd/ NiMH/Li-Ion batteries (except Univolt batteries)
- Charges the battery in 1 hour
- The DeWalt® 3-stage charging system provides maximum run-time and extends overall life of the battery
- Voltage: 7.2V-18 V



Item #

DTDC9310

Wet & Dry Vacuum

Portable

DeWalt



Specifications:

- Tank Size: 1/2 gal.
- Hose diameter: 1-1/4"
- Hose length: 2.5'
- Voltage (DC Operation): 18V
- Includes: (1) 18V Nicad battery

Item #

DTDC515K

1 Hour Vehicle Charger

7.2V-18V, NiCd/NiMH/Li-Ion

DeWalt

- Charges 7.2V-18V NiCd/NiMH/Li-Ion DeWalt® batteries (except Univolt®) from a vehicle's power outlet
- Charges in 1 hour or less
- Automatic shut-off protects excessive discharge of vehicle's battery



Item #

DTDC9319

Worksite Charger/Radio

- 1 hour charger for 7.2V to 18V DeWalt battery packs (except Univolt®)
- Runs off of 7.2V to 18V DeWalt batteries making it a cordless radio
- The DeWalt 3 - stage charging system provides maximum run-time and extends overall life of the battery
- Power outlets offer more versatility for jobsite power
- AM/FM Digital Tuner with LCD display, built-in clock, and 15 station memory presets
- High efficiency weather resistant speakers with dual bass ports for maximum bass and range
- Auxiliary port allows connection to CD Players, MP3 Players, and portable satellite receivers
- Dual pivoting 11" flexible antenna provides more durability and better reception



Item #

DTDC012

1 Hour Dual Port Battery Charger

7.2V-18V NiCd/NiMH/Li-Ion

DeWalt

- Charges (2) DeWalt® 7.2V - 18V NiCd/NiMH/Li-Ion batteries (except Univolt batteries)
- Charges the battery in 1 hour or less thus minimizing downtime
- The DeWalt® 3-stage charging system provides maximum run-time and extends overall life of the battery



Item #

DTDC9320



20V MAX* Lithium Ion Compact Drill/Driver Kit (1.5 Ah)

- Compact, lightweight design fits into tight areas
- High speed transmission delivers 2 speeds (0-600 & 0-2,000 rpm) for a range of fastening and drilling applications
- Ergonomic handle delivers comfort and control
- Heavy-duty 1/2" ratcheting chuck provides superior bit gripping strength
- 3 Year Limited Warranty
- Includes: 1/2" Drill Driver, (2) 20V MAX* Lithium Ion Battery Packs, 30 Minute Fast Charger, Belt Hook, On-Board Bit Holder, Kitbox



Item #	Max Power	Max RPM	Clutch Settings	Tool Wt. (lbs.)	Tool Length (in.)
DTDCD780C2	350UWO	2000	15	3.4	7.5

20V MAX* Lithium Ion 1/4" Impact Driver Kit (1.5 Ah)

- Compact (5.55" front to back), lightweight (2.8 lbs) design fits into tight areas
- Three (3) LED lights with 20 second delay after trigger release, provide visibility without shadows
- One-handed loading 1/4" hex chuck accepts 1" bit tips
- Belt hook included for portability
- Includes: 1/4" Impact Driver, (2) 20V MAX* Lithium Ion 1.5 Ah Battery Packs, 30 Minute Fast Charger, Belt Hook, Kitbox



Item #	Voltage	No Load Speed RPM	Impacts/Min	Max Torque (in/lbs)	Max Torque (ft./lbs.)	Tool Wt. (lbs.)	Tool Length (in.)
DTDCF885C2	20V MAX*	2800	3200	1400	117	2.8	5.55

20V MAX* Lithium Ion Premium 3-Speed Hammerdrill Kit (3.0 Ah)

- DeWalt® 20V Max* Lithium Ion batteries offer longer tool runtime & enhanced durability
- 3-speed all-metal transmission matches the tool to task for fastest application speed and improved run time
- Heavy-duty 1/2" metal ratcheting chuck with carbide inserts provides superior bit gripping strength
- LED light with 20 second delay after trigger release
- High power, high efficiency motor delivers 535 unit watts out of max power for superior performance in all drilling and fastening applications
- Includes: 1 Hour Charger, (2) 20V MAX* Lithium Ion Batteries, 360° Side Handle, Kit Box



Item #	Max Power	# Of Speed Settings	Max RPM	Max BPM	Clutch Settings	Tool Wt. (lbs.)
DTDCD985L2	535UWO	3	0-575/0-1350/0-2000	0-9775/0-22950/0-34000	22	5.2

20V MAX* Lithium Ion Premium 3-Speed Drill/Driver Kit (3.0 Ah)

- DeWalt® 20V MAX* Lithium Ion batteries offer longer tool runtime & enhanced durability
- 3-speed all-metal transmission matches the tool to task for fastest application speed and improved run time
- Heavy-duty 1/2" metal ratcheting chuck with carbide inserts provides superior bit gripping strength
- High power, high efficiency motor delivers 535 unit watts out of max power for superior performance in all drilling and fastening applications
- Includes: 1 Hour Charger, (2) 20V MAX* Lithium Ion Batteries, 360° Side Handle, Kit Box



Item #	Max Power	# Of Speed Settings	Max RPM	Clutch Settings	Tool Wt. (lbs.)	No Load Speed	Tool Length (in.)
DTDCD980L2	535UWO	3	0-575/0-1350/0-2000	22	5.2	RPM	9%



20V MAX* Lithium Ion 4-Tool Combo Kit (3.0 Ah)



- DCD985 20V MAX* hammerdrill with patented 3-speed all-metal transmission & 1/2" all metal ratcheting chuck delivers 535 units watts out of maximum performance, faster application speed, & superior bit retention
- DCS381 20V MAX* reciprocating saw with keyless blade clamp allows for quick blade change without touching blade or reciprocating shaft
- DCF885 20V MAX* 1/4" impact driver features 3 LED lights with 20 second delay to provide visibility without shadows
- DCL040 20V MAX* LED work light has 110 lumens of light output
- Includes: 1/2" Hammerdrill, Reciprocating Saw, 1/4" Impact Driver, LED Work Light, (2) 20V MAX* Lithium Ion 3.0 Ah Battery Packs, Fast Charger, 360° Side Handle, Belt Hook, Contractor Bag

Item #	Shipping Weight (lbs.)
DTDCK490L2	20.9

20V MAX* Lithium Ion 1/4" Impact Driver Kit (3.0 Ah)



- Compact (5.55" front to back), lightweight (3.4 lbs) design fits into tight areas; belt hook included for portability
- Three (3) LED lights with 20 second delay after trigger release, provide visibility without shadows
- One-handed loading 1/4" hex chuck accepts 1" bit tips
- No Load Speed: 2800 RPM; Impacts/Min.: 3200
- Includes: 1/4" Impact Driver, (2) 20V MAX* Lithium Ion 3.0 Ah Battery Packs, Fast Charger, Belt Hook, Kitbox

Item #	Max Torque (in/lbs)	Max Torque (ft./lbs.)	Tool Wt. (lbs.)	Tool Lgth. (in.)
DTDCF885L2	1400	117	3.4	5.55

20V MAX* Lithium Ion 5-Tool Combo Kit (3.0 Ah)



- DCD985 20V MAX* hammerdrill with patented 3-speed all-metal transmission & 1/2" all metal ratcheting chuck delivers 535 units watts out of maximum performance, faster application speed, & superior bit retention
- DCS381 20V MAX* reciprocating saw with keyless blade clamp allows for quick blade change without touching blade or reciprocating shaft
- DCF885 20V MAX* 1/4" impact driver features 3 LED lights with 20 second delay to provide visibility without shadows
- DCS393 20V MAX* circular saw with 6-1/2" carbide blade can cut 2x4's at a 45° angle in a single pass
- DCL040 20V MAX* LED work light has 110 lumens of light output
- Includes: 1/2" Hammerdrill, Reciprocating Saw, 1/4" Impact Driver, 6-1/2" Circular Saw, LED Work Light, (2) 20V MAX* Lithium Ion 3.0 Ah Battery Packs, Fast Charger, 360° Side Handle, Belt Hook, Carbide Tipped Blade, Contractor Bag

Item #	Shipping Weight (lbs.)
DTDCK590L2	29.9

20V MAX* Lithium Ion Reciprocating Saw Kit (3.0 Ah)



- 4-Position Blade Clamp allows for flush cutting and increased positional versatility with tool free blade changes
- 1-1/8" stroke length delivers a fast cutting speed
- Variable speed trigger with 0-3000 spm provides increased blade control and faster cut speeds; pivoting adjustable shoe extends blade life and allows depth of cut control
- Rubber over molded comfort grip delivers optimal comfort and control; double oil sealed shaft resists contamination and increases durability
- Includes: Reciprocating Saw, (1) 20V MAX* Lithium Ion 3.0 Ah Battery Pack, Fast Charger, Kitbox

Item #	Stroke Length (in.)	Tool Wt. (lbs.)
DTDCS380L1	1 1/8	7.35

20V MAX* Lithium Ion 6-1/2" Circular Saw Kit (3.0 Ah)



- Powerful 460 MWO, 3700 rpm motor delivers power and speed to make the most demanding cuts with ease
- High strength and lightweight magnesium shoe provides jobsite durability for long-term cut accuracy; optimized rubber overmolded comfort grip delivers optimal balance and control
- 0°-50° bevel capacity allows for aggressive bevel cuts for a multitude of applications; 6-1/2" carbide tipped blade for cutting 2x material at 90° and 45° and more cuts per charge
- 20V MAX* Lithium Ion 3.0 AH battery
- Includes: 6-1/2" Circular Saw, (1) 20V MAX* Lithium Ion 3.0 Ah Battery Pack, Fast Charger, 6-1/2" Carbide-tipped Blade, Kit Box

Item #	No Load Speed RPM	Arbor Size (in.)	Depth of Cut at 45° (in.)	Depth of Cut at 90° (in.)	Tool Wt. (lbs.)
DTDCS391L1	3700	5/8	1 5/8	2 1/4	8.0

20V MAX* Lithium Ion 3 Mode SDS Rotary Hammer Kit (3.0 Ah)



- Shocks™ - Active Vibration Control significantly reduces vibration and increases user comfort and productivity
- 1.7 ft-lbs impact energy provides corded power without the cord; 360° side handle for better control and ease of use in tight spaces
- LED worklight provides increased visibility in confined spaces; compact L-shape design allows access in tight spaces while providing optimal balance
- Variable speed, reversing switch delivers versatility in all applications; factory-set clutch reduces sudden, high torque reactions if bit jams
- No Load Speed: 0-1100 RPM; Vibration Measurement: 8.0 m/s²
- 20V MAX* Lithium Ion 3.0 AH battery
- Includes: 1 Hour Charger, (2) 18V Li-Ion batteries, 360° Side Handle, Depth Rod, Kit Box

Item #	Concrete Optimum	Beats/Min. (BPM)	Tool Length (in.)	Tool Wt. (lbs.)
DTDCH213L2	5/32 - 1/2"	0-4100	10.5	6.4



20V MAX* Lithium Ion Battery Pack (3.0 Ah)



- 3.0 Ah extended run-time battery provides long run-time & battery life
- No memory and virtually no self-discharge for maximum productivity and less downtime
- Weighs 1.6 lbs allowing user maximum runtime and a light weight battery
- Compatible with entire line of DeWalt® 20V MAX* tools

Item #

DTDCB200

12V MAX* - 20V MAX* Lithium Ion Battery Charger



- Charges all DeWalt® 12V - 20V MAX* Li-Ion batteries
- Charges the battery in 1 hour or less thus minimizing downtime
- Diagnostics with LED indicator communicates battery charge status: charged, charging, power line problem, replace pack, and battery too hot or too cold

Item #

Tool Wt. (lbs.)

DTDCB101

1.23

1/4" Screwdriver Kit 12V

12V MAX* Lithium Ion Tools

Dewalt



- 0-1,050 RPM
- Compact, lightweight, only 2.2 lbs. design fits into tight areas
- 3 LED Lights
- One-handed loading 1/4" hex chuck accepts 1" bit tips
- Includes: (2) 12v Lithium-Ion batteries, charger, belt hook, case

Item #

DTDCF610S2

3/8" Drill Driver Kit 12V

12V MAX* Lithium Ion tools

Dewalt



- Two speed transmission for optimal speed and torque control; 0-400 / 0-1,500 rpm
- Compact, lightweight, only 2.4 lbs., fits into tight areas
- 3/8" single sleeve keyless chuck
- LED light
- Includes: (2) 18v Lithium-Ion batteries, charger, belt hook, case

Item #

DTDCD710S2

1/4" Impact Driver 12V

12V MAX* Lithium Ion Tools

Dewalt



- 0-2450 RPM
- Compact, lightweight, 2.3lbs.
- 3 LED Lights
- One-handed loading 1/4" hex chuck accepts 1" bit tips
- Includes: (2) 12v Lithium-Ion batteries, charger, belt hook, case

Item #

DTDCF815S2

3/8" Impact Wrench Kit 12V

12V MAX* Lithium Ion Tool

Dewalt



- Compact, lightweight, 2.3 lbs.
- 3 LED Lights
- 3/8" Hog ring anvil
- 1150 in/lbs of torque
- Includes: (2) 12v Lithium-Ion batteries, charger, case

Item #

DTDCF813S2

Inspection Camera 12V

12V MAX* Lithium Ion Tool

Dewalt



- Removable wireless screen for ease of viewing when in tight areas
- Photo and video capturing on micro SD card to help with documentation (SD card sold separately)
- Hook and magnet accessories included to aid in retrieval
- 3.5" screen for increased visibility; 3x zoom capability for better visibility
- Includes: 3 ft. cable, (1) 12v Lithium-Ion battery, charger, case

Item #

DTDC410S1

Infrared Thermometer Kit 12V

12V MAX* Lithium Ion Tool

Dewalt



- Non-contact temperature measurements (-20°F to 932°F) for ease of use over distance and accuracy
- LED hot (red) & cold (blue) indicator for visual and/or audio alarm for quickly locating trouble spots
- Data storage for recording max, min, and average temperatures
- Adjustable emissivity improves accuracy across a wide range of materials
- Includes: (1) 12v Lithium-Ion battery, charger, case

Item #

DTDC414S1



LED Worklight 12V

12V MAX* Lithium Ion
Dewalt

- Bright LED output - 130 Lumens
- Powerful magnet - hands free use in multiple placements
- Kick stand - hands free use in multiple placements
- Head rotates 360° and pivots



Item #
DTDCL510

12V MAX* Fastcharger

12V MAX* Lithium Ion Tools
Dewalt

- Charges all DeWalt® 12V MAX* Li-Ion batteries; charges the battery in 40 minutes or less
- Diagnostics with LED indicator communicates battery charge status: charged, charging, power line problem, replace pack, and battery too hot or too cold



Item #
DTDCB100

12V MAX* Lithium Ion Battery Pack

12V MAX* Lithium Ion Tools
Dewalt

- Compact, light weight design; quick 40 minute charge time
- No memory and virtually no self-discharge for maximum productivity and less downtime
- Requires 12V MAX* compatible charger (DCB100)



Item #
DTDCB120

Screwdriver/Impact Driver Combo Kit 12V

12V MAX* Lithium Ion
Dewalt

- DCF610 12V MAX* screwdriver features 1/4" one hand loading hex chuck
- DCF815 12V MAX* 1/4" impact driver features 3 LED lights to provide visibility without shadows
- Includes: (2) 12v Lithium-Ion batteries, charger, case



Item #
DTDCK210S2

Drill Driver/Impact Driver Combo Kit 12V

12V MAX* Lithium Ion Tool
Dewalt

- DCD710 12V MAX* 3/8" drill/driver features two speed transmission (0-400 / 0-1,500)
- DCF815 12V MAX* 1/4" impact driver features 3 LED lights to provide visibility without shadows



Item #
DTDCK211S2

12V Cordless Drill/Driver Kit

1/2"
DeWalt

- XRP™ extended run-time batteries provide long run-time and battery life
- Patented 3-speed all-metal transmission



Specifications:

- # of Speed Settings: 3
- Max RPM: 0-425/0-1,200/0-1,800
- Clutch Settings: 22
- Chuck Size: 1/2"
- Includes: 1 hour charger, (2) 12V XRP™ batteries, kit box

Item #
DTDCD910KX

12V Cordless Impact Wrench Kit

1/4"
DeWalt

- 1,150 in-lbs of torque
- 0-2,400 rpm/0-2,700 ipm



Specifications:

- Voltage: 12 V
- Drive Size: 1/4" hex shank quick release in
- No Load Speed: 0-2,400 rpm
- Impacts/Min: 0-2,700 ipm
- Includes: 1 hour charger, (2) 12V XRP™ batteries, kit box

Item #
DTDC845KA

Dust Extractor Telescope w/ Hose for SDS Rotary Hammers

DeWalt

- Dust extractor telescope and side-handle fits DeWalt corded and cordless SDS rotary hammers



Item #
DTD25301D



HEPA Dust Extraction for L-Shape SDS Hammer

DeWalt



- For use with D25303, D25304, D25313, D25314, D25323, and D25324 hammers
- HEPA filter delivers 95% efficiency at 0.3 microns
- Built-in motor keeps performance high while drilling
- 2-second power-off delay allows dust extraction to continue after drill is switched off

Item #

DTD25300DH

14.4V Cordless 1/2" Drill/Driver Kit

DeWalt



- High power, high efficiency motor delivers 285 unit watts out of max power

Specifications:

- # of Speed Settings: 3
- Max RPM: 0-425/0-1,200/0-1,800
- Clutch Settings: 22
- Chuck Size: 1/2"
- Includes: 1 hour charger, (2) 14.4V XRP™ batteries, kit box

Item #

DTDCD920KX

14.4V Cordless Impact Wrench Kit

1/4"
DeWalt



- 0-2,400 rpm/0-2,700 ipm for faster application speed

Specifications:

- Drive Size: 1/4" hex shank quick release in
- No Load Speed: 0-2,400 rpm
- Includes: 1 hour charger, (2) 14.4V XRP™ batteries, kit box

Item #

DTDC835KA

14.4V Cordless Flashlight

Pivoting Head
DeWalt



- Pivoting head rotates 90°; wide-angle beam
- Extra-bright Xenon bulb (DW9063); spare bulb inside lens cover

Item #

DTDW906

14.4V Cordless Swivel Head Shears Kit

18 Gauge
DeWalt



- 14.4 volt 18 gauge
- 0-2300 SPM, 5.1 lbs.
- Swivel head rotates 360°; fan cooled motor with electric brake
- 1,200 cycle XR pack™
- Includes: (1) 14.4v battery, charger, case

Item #

DTDW941K-2

6.5 Amp Reciprocating Saw Kit

1-1/8" Stroke Length
DeWalt



- 1-1/8" Stroke length
- Variable speed, 0-2,400 spm
- Includes: saw, metal blade, case

Item #

DTDW304PK

13.0 Amp Reciprocating Saw

Variable Speed
DeWalt



- Orbital action for fast wood cutting applications
- Powerful 13.0 amp motor
- Keyless blade clamp; keyless adjustable shoe
- Variable speed dial matches the correct speed with the application for increased versatility and control
- Includes: Saw, Metal Blade, Case

Item #

DTDW311K

Worm Drive Circular Saw

7-1/4"
DeWalt



- 13.8 lbs. Lightweight magnesium construction; durable cast magnesium footplate provides a tough and solid cutting platform
- Extra wide saw hook accepts material up to 2-1/2" wide
- Toughcord™ Cord Protection System
- 53° Bevel capacity; Bevel detents at 22.5° and 45°
- Dual rip ports to accept available DWS5100 12" Dual Port Rip Guide
- Top-accessible spindle lock

Item #

DTDWS535



15 Amp Circular Saw

Heavy-Duty, 8-1/4"
DeWalt



- 15.0 Amp, high-torque motor
 - Electric brake stops blade after use
 - Heavy-gauge, high-strength aluminum alloy base
- Specifications:

- No Load Speed: 5,800 RPM
- Spindle Lock: Yes; Electric Brake: Yes

Item #
DTDW384

7-1/4" Circular Saw Kit

15 Amps
DeWalt



- 9.5 lb. light weight tool ergonomically designed
- 15 Amp, 2,200 MWO motor powerful enough for the toughest applications
- 56° beveling capacity

Item #
DTDW369CSK

15 Amp Circular Saw

7-1/4"
DeWalt



- 120V, 5800 RPM, high torque motor
- Two-second electric brake
- 100% ball and roller bearings; 50% bevel capacity
- Shoe provides 1-1/2" edge distance that matches dimensional lumber thickness

Item #
DTDW364

Lightweight Circular Saw

7-1/4"
DeWalt



- 15 Amp, 2,200 MWO motor
 - 56° beveling capacity with stops at 45° and 22.5°
 - Magnesium shoe designed for increased durability; clear line of sight aids in blade visibility from any angle
 - Lower guard design improves performance when making bevel cuts and cutting shims
- Specifications:

- No Load Speed: 5,800 RPM; Blade Diameter: 7-1/4"

Item #
DTDW368

Jig Saw Kit

Variable Speed
DeWalt



- Accepts only T-shank blades for optimal holding power ion
- Stroke Length: 1"
- Keyless Blade Clamp: Yes
- Dust Blower: Yes
- Orbital Action: 4-position
- 6.5 amps
- Includes: Saw, Metal Blade, Case

Item #
DTDW331K

Compact Jig Saw Kit

DeWalt



Specifications:

- Amps: 5.5 Amps
- Strokes/Min: 0-3,100 spm
- Stroke Length: 1"
- Keyless Blade Clamp: Yes
- Dust Blower: N/A
- Orbital Action: 4-position

Item #
DTDW317K

1.3 Amp Scroll Saw

20"
DeWalt



- 3/4" Stroke length
- Double parallel-link arm
- Exclusive tool-free blade holders
- On-off switch, electronic variable speed, flexible dust blower and blade-tensioning lever are all located on the front upper arm
- Arm design moves the tool's pivot points from the back of the saw to the front, shortening the arm movement for smoother, quieter operation
- Unique arm design keeps the blade perpendicular to the work
- SPM: 400-1,750
- Max. Depth of Cut: 2"
- 1.3 amps

Item #
DTDW788



Single-Bevel Compound Miter Saw

10"
DeWalt

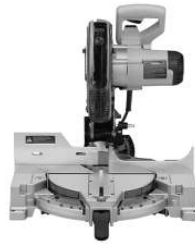

- Stainless steel detent plate with 11 positive stops provides repeatable accuracy and jobsite durability
- Cam miter lock for quick and accurate miter table positioning
- Miter detent override for fine adjustment and precise miter angles
- 0-50° left and right miter capacity
- Bevels 3°-48°
- Laser compatible, designed for use with the DWS7085 LED work-light

Specifications:

- Amps: 15 Amps; No Load Speed: 5,000 RPM
- Blade Diameter: 10"; Arbor Size: 5/8"

Item #
DTDW713

Single-Bevel Compound Miter Saw

12"
DeWalt



- Adjustable stainless steel miter detent plate with 11 positive stops improves productivity and ensures cutting
- Bevels 0°-48° to the left and 0°-3° to the right
- 0°-50° left and right miter capacity
- Cam lock miter handle with detent override deliver quick and accurate miter angles
- 4 Hardened Steel Bevel Stops at 0°, 33.9°, 45° and 48°

Specifications:

- Amps: 15 Amps; No Load Speed: 4,000 RPM
- Blade Diameter: 12"; Arbor Size: 5/8" or 1"

Item #
DTDW715

Double-Bevel Sliding Compound Miter Saw

10"
DeWalt



- Exclusive bevel detent system - 7 positive stops; adjustable stainless steel miter detent plate with 11 positive stops
- Dual horizontal steel rails with innovative clamping mechanism and linear ball bearings
- Cross cut capacity 12" at 45° angle using back fence design
- Miter capacity left 60° and right 52°; bevels 0-48° for increase cut capacity

Specifications:

- Amps: 15 Amps; No Load Speed: 4,000 RPM
- Blade Diameter: 10"; Arbor Size: 5/8"

Item #
DTDW717

Double-Bevel Sliding Compound Miter Saw

12"
DeWalt



- Adjustable stainless steel miter detent plate with 10 positive stops
- Innovative gearbox and belt-drive design increases vertical cutting capacity
- Single lever action double bevel design easily bevels left and right 0° - 48° with positive stops at 0°, 22.5°, 33.9° and 45° in both directions
- Exclusive Back Fence Design cuts up to 2x16 dimensional lumber at 90° and 2x12 at 45°; miters 60° to the left and 50° to the right

Specifications:

- Amps: 15 Amps; No Load Speed: 3,600 RPM
- Blade Diameter: 12"; Arbor Size: 5/8" or 1"

Item #
DTDW718

Jobsite Compact Table Saw

10"
DeWalt



- Rack and pinion fence rails make fence adjustments fast, smooth and accurate; telescoping fence rails retract to create a small, portable package
- 16" of rip; 24T carbide blade enhances cut quality
- Dust port allows for 2-1/2" vacuum hook up

Specifications:

- Amps: 15 Amps; No Load Speed: 3,850 rpm
- Blade Diameter: 10"; Arbor Size: 5/8"
- Dust Port Diameter: 2-1/2"

Item #
DTDW745



6-1/2" Track Saw Kit

w/59" Track
DeWalt



- Zero clearance TrackSaw™ cutting system delivers precise, straight, splinter-free cuts
- For use with TrackSaw™ dual-edged tracks for perfectly straight cuts in both directions
- On-track cut depth: 2-1/8" @ 90°, 1-5/8" @ 45°; depth scale accurately indicates exact depth of cut accounting for track thickness
- Straight Plunge Mechanism
- Universal 1-1/4" Dust Port for 90% efficient dust collection with vacuum

Specifications:

- Power: 12 Amp; No Load Speed: 1750 - 4000 RPM
- Blade Diameter: 6-1/2" (165 mm)

Item #
DTDWS520SK

Miter Saw Stand

Heavy-Duty
DeWalt



- Universal design works with all brands of miter saw
- Lightweight aluminum construction (35 lbs.) allows for easy transport to and from the jobsite
- 5-1/2' beam extends to support up to 16 ft. of material and up to 400 lbs.
- Includes: 2 convertible work supports/stops

Item #
DTDW723

Table Saw Stand

Portable
DeWalt



- All-metal construction
- Folds up for easy storage; lightweight and durable

Item #
DTDW7440

Scroll Saw Stand

All-Metal Construction
DeWalt



- All-metal construction
- Adjustable legs

Item #
DTDW7880

1/2" VSR Mid-Handle Grip Drill

w/Keyless Chuck
DeWalt



- 10.0 Amp motor delivers high performance in heavy-duty applications
- Specifications:
- Chuck Size: 1/2"; Keyless Chuck: yes
 - Amps: 10.0 Amps; No Load Speed: 0-1,200 RPM
 - Capacity In Wood: 1-1/2"; Capacity In Steel (Twist Bit): 1/2"
 - Includes: 360° locking side handle with soft grip

Item #
DTDWD215G

7.2 Amp 1/2" Hammerdrill

Keyed Chuck
DeWalt



- Variable speed 120 V, 0-1,100/0-2,700 rpm; 0-19,000/0-46,000 BPM
- Dual mode: hammerdrill/drill for wood, steel or masonry applications

Bit Capacity:

- Concrete: Optimum - 3/16"-3/8"; Maximum - 1/2"
- Wood: 1/2" (low); Steel: 3/8" (low)

Item #
DTDW505

7.8 Amp 1/2" Electric Drill

Keyed Chuck With Side Handle
DeWalt



- 0-850 rpm with ground plug

Wood applications:

- Spade bit - 1-1/2"

Steel applications:

- Twist bit - 1/2"

Item #
DTDW235G

7.8 Amp 1/2" Electric Drills

w/Side Handle
DeWalt



- Variable speed 0-600RPM
- DW246: Keyless chuck with spindle lock
- DW245 Keyed Chuck

Wood applications:

- Spade bit - 1-1/2"

Steel applications:

- Twist bit - 3/4"

Item #
DTDW245
DTDW246



7.8 Amp 1/2" Electric Drill

Keyless Chuck
DeWalt



- VSR 0-850 RPM
- Wood applications:
- Spade bit - 1-1/2"
- Steel applications:
- Twist bit - 1/2"

Item #
DTDW236

1/2" VSR Stud & Joist Drill

w/Clutch and Bind-up Control®
DeWalt



- Bind-Up Control™ stall-sensing technology for increased control of reactionary torque
- Mechanical clutch in low speed delivers increased gear protection

Specifications:

- Chuck Size: 1/2"
- No Load Speed: 0-330/0-1300 rpm
- Amps: 11.0 Amps
- Clutch: Yes
- Capacity In Wood (Spade Bit): 1-1/2"
- Capacity In Wood (Self-Feed): 4-5/8"
- Capacity In Wood (Hole Saw): 6"
- Capacity In Wood (Auger Bit): 1-1/2"
- Capacity In Steel (Twist Bit): 1/2"
- Capacity In Steel (Hole Saw): 5"
- Includes: Chuck key with holder, 2-position side handle, bail handle

Item #
DTDW460

7 Amp 1/2" Spade Handle Drill

Keyed Chuck
DeWalt



- 120V AC/DC, forward/reverse rocker switch, 450RPM
- 5/8" spindle for durability in high torque applications
- Wood applications:
- Spade bit - 1-1/2"
- Steel applications:
- Twist bit - 1/2"

Item #
DTDW130V

3/8" VSR Mid-Handle Drill Kit

With Keyless Chuck
DeWalt



- 8.0 Amp motor
- 0-2,500 RPM, VSR trigger
- Mid-handle grip design with soft grip offers increased balance and comfort
- Capacity In Wood (Spade Bit): 1"
- Capacity In Wood (Hole Saw): 1-1/8"
- Capacity In Steel (Twist Bit): 3/8"
- Includes: Heavy-duty kit box

Item #
DTDWD115K

3/8" VSR Pistol Grip Drill Kit

W/Keyless Chuck
DeWalt



- 7.0 Amp motor
- 3/8" All-metal ratcheting keyless chuck
- 0-2,500 RPM, VSR trigger N/A; (Hole Saw) 1-1/8"; (Auger Bit) N/A;
- Capacity In Steel (Twist Bit) 3/8"; (Hole Saw) N/A
- Includes: Heavy-duty kit box

Item #
DTDWD112

6.7 Amp 3/8" VSR Drill

Heavy-Duty
DeWalt



- Amps: 6.7
- No Load Speed (rpm): 0 - 1,500
- Chuck (in.): 3/8

Item #
DTDW222

3.7 Amp 3/8" Right Angle Drill

Keyed Chuck
DeWalt



- Compact right-angle design for easy access in tight places
- Paddle switch; Spindle Lock

Specifications:

- Chuck Size: 3/8"; Keyless Chuck
- Amps: 3.7 Amps; No Load Speed: 0-1,200 RP,
- Capacity In Wood (Spade Bit): 1-1/8"; Capacity In Steel (Twist Bit): 3/8"
- Includes: Chuck key with holder

Item #
DTDW160



6.0 Amp 3/8" Pistol Grip Electric Drill

DeWalt

- Built-in two-way level for drilling accurate vertical and horizontal holes
- Chuck Size: 3/8"
- No Load Speed: 0-2,500 RPM; Amps: 6.0 Amps
- Gear Reduction: Single
- Capacity In Wood (Spade Bit): 1"
- Capacity In Wood (Hole Saw): 1-1/8"
- Capacity In Steel (Twist Bit): 3/8"
- Includes: Chuck key with holder



Item #

DTD21002

7 Amp 1/4" Electric Drill

Keyless Chuck

DeWalt

Wood applications:

- Spade bit - 1-1/4"
- Hole saw - 2-1/8"

Steel applications:

- Twist bit - 3/8"
- Hole saw - 1-1/2"
- 6.7 amps



Item #

DTDW217

Screwdriver

DeWalt

- Depth sensitive
- 6.0 Amps, 0-4,000 rpm, 60 in. lbs. Amps/RPM Torque



Item #	Max. Fastener Size
DTDW252	#8

DTDW252

#8

6.2 Amp All-Purpose Screwdriver Kit

Heavy-Duty, VSR

DeWalt

- High-power, multi-purpose kit for self-drilling fasteners in steel, deck/subfloor installation and drywall applications
- Depth sensitive, "set and forget" nose-piece for consistent fastener depth
- Amps: 6.2; No Load Speed (RPM): 0 - 2,500
- Standard clutch



Item #

DTDW260K

6.3 Amp VSR Drywall Screwdriver

Heavy-Duty

DeWalt

- Metal gear housing for increased durability
- Depth-sensitive, "set and forget" nose-piece

Specifications:

- Amps: 6.3; No Load Speed: 0-4,000 rpm
- Clutch: Standard



Item #

DTDW272

6.5 Amp VSR Screwdriver

Heavy-Duty

DeWalt

- Versa-Clutch® system to "dial" the proper torque needed to efficiently drive fasteners without stripping or breaking fastener with override capability

- Amps: 6.5; No Load Speed: 0 - 2,000 RPM



Item #

DTDW268

1/2" Impact Wrench

w/Detent Pin Anvil

DeWalt

- 1/2" detent pin anvil; AC/DC forward/reverse rocking switch

Specifications:

- Amps: 7.5 Amps; No Load Speed: 2,100 rpm
- Max. Torque: 345 ft-lbs; Impacts/Min: 2,700 ipm



Item #

DTDW292

3/4" Impact Wrench

w/Detent Pin Anvil

DeWalt

- 3/4" detent pin anvil
- AC/DC forward/reverse rocking switch

Specifications:

- Amps: 7.5 Amps; No Load Speed: 2,100 RPM
- Max. Torque: 345 ft-lbs
- Impacts/Min: 2,700 ipm



Item #

DTDW294



3/4" Impact Wrench

DeWalt

- Easy forward or reverse, can run on AC or DC current
- Specifications:
- Amps: 7.5 Amps
 - No Load Speed: 1,600 RPM
 - Max. Torque: 434 ft-lbs
 - Impacts/Min: 1,800 ipm



Item #

DTDW297

Rotary Hammer Kit

7/8" SDS

- 6.9 amp motor provides high performance: (0-1,550 RPM, 0-4,550 BPM)
- Variable speed trigger controls speed from 0 to dialed setting
- Mode selector allows for usage in rotary hammer, rotary only, and chiseling applications
- Reversing feature helps release tool from bind up situations
- Integral clutch reduces sudden, high torque reactions if bit jams
- 360-degree side handle adjusts easily
- D-handle design offers preferred balance



Item #

DTD25023K

Rotary Hammer

1" SDS

DeWalt

- Reverse feature assists in the removal of fasteners
- Variable speed allows for precise hole placement on work surface
- Amps: 8.0 Amps
- Chipping: Yes
- Loaded Speed: 0-850 rpm
- Blows/Min: 0-4,300 bpm



Item #

DTD25213K

Rotary Hammer

1" SDS

- 8 amp motor provides high performance: 0-1,150 RPM, 0-4,300 BPM
- Variable speed trigger controls speed from 0 to dialed setting
- Delivers 2.5 ft. lbs. of Impact Energy
- SHOCKS – Active Vibration Control® reduces vibration up to 50%
- Mode selector allows for usage in rotary hammer, rotary only, and chiseling applications
- Reversing feature helps release tool from bind up situations
- Integral clutch reduces sudden, high torque reactions if bit jams
- 360 degree side handle adjusts easily



Item #

DTD25223K

SDS Max Rotary Hammer

1-3/4"

DeWalt

- 13.5 Amp high-performance motor provides high performance; 210-415 rpm; 1430-2840 bpm
- 9.5 ft-lbs. of Impact Energy provides fast drilling and powerful chipping
- Shocks - Active Vibration Control® reduces vibration up to 50%
- Complete Torque Control (CTC)® - Patented 2-Stage clutch provides maximum control in bind up situations
- Rear handle mount increases user comfort
- Trigger lock-on reduces user fatigue while chipping



Item #

DTD25602K

Three Mode SDS Hammer

1" L-Shape

DeWalt

- L-Shape design offers superior balance and control
 - At only 11-1/2" this hammer is the most compact in the market
 - Light weight design (6.5 lbs) provides comfort for extended use
- Specifications:
- Optimal Concrete Drilling: 5/32" - 5/8"
 - Amps... 8.0 Amps
 - Blows/Min: 0-4,300 bpm
 - Clutch: Yes - Factory Set



Item #

DTD25313K



Rotary Hammer

1" L-Shape



- 8 amp motor provides high performance and overload protection: 0-1,150 RPM, 0-4,300 BPM
- Variable speed trigger allows user to instantly control speed from 0 to dialed setting
- Delivers 2.5 ft lbs. of Impact Energy, providing fast drilling and powerful chipping
- SHOCKS – Active Vibration Control® reduces vibration up to 50% while increasing user comfort and productivity
- Mode selector allows for usage in rotary hammer, rotary only, and chiseling applications; Reversing feature helps release tool from bind up situations, and assists with removal of fasteners
- Integral clutch reduces sudden, high torque reactions if bit jams; 360 degree side handle adjusts easily for preference or use in tight spaces
- Dust Extraction Connection allows the use of the D25300DH dust collection system

Item #
DTD25323K

SDS Max Combination Hammer

1-7/8"

DeWalt



- SHOCKS – Active Vibration Control® reduces vibration up to 50%
- Complete Torque Control (CTC)® - Patented 2 Stage clutch provides maximum control in bind up situations
- 13 Amp motor provides maximum performance; 210-415 rpm; 1430-2840 bpm; 11.7 ft lbs. of Impact Energy
- Rear handle mount means less bending over when using tool in downward chipping applications; Trigger Lock On provides increased user comfort in extended use chipping applications

Item #
DTD25712K

SDS Max Combination Hammer

2"

DeWalt



- SHOCKS – Active Vibration Control® reduces vibration by up to 50%
- Complete Torque Control (CTC)® utilizes patented 2-stage clutch for maximum control in bind-up situations
- 15 Amp motor provides maximum overload protection & power; 15 ft-lbs of impact energy provides maximum performance in drilling & chipping
- Rear handle mount means less bending over when using tool in down drilling applications; Lock-on slide switch provides increased user comfort in extended use applications

Item #
DTD25762K

SDS Max Demolition Hammer

22 lb., w/Shocks

DeWalt



- Active Vibration Control AVC™ reduces vibration
- SDS max tool holder with rubber dampers absorbs energy providing longer life

Specifications:

- Amps: 14 Amps
- Loaded Speed (bpm): 1,020-2,040 bpm

Item #
DTD25901K

Spline Rotary Hammer Kit

1-3/4"

DeWalt



- 13.5 Amp motor Provides maximum performance & overload protection
- 9.5 ft-lbs. Impact Energy provides fast drilling and powerful chipping
- Complete Torque Control (CTC)® - Patented 2 Stage clutch provides maximum control in bind up situations
- Shocks – Active Vibration Control® reduces vibration up to 50% while increasing user comfort and productivity
- Electronic variable speed allows the user to control the speed of drilling and chipping while maintaining speed under load
- Rear handle mount means less bending over when using tool in down drilling applications
- Trigger Lock On provides increased user comfort in extended use chipping applications

Item #
DTD25651K

Rotary Hammer Kit

1-9/16" Heavy-Duty

DeWalt



- 12.0 Amp motor high performance and overload protection, 490 rpm, 3300 bpm
- 8.0 ft-lbs of impact energy provides fast drilling and powerful chipping
- Rear handle mount for increased user comfort in down drilling applications
- Rubber grip helps reduce the level of vibration felt by the user
- Factory-set clutch reduces sudden, high torque reactions if bit jams

Item #	Chuck Type
DTD25553K	Spline



Pavement Breaker - Electric

w/ Hammer Truck and Steel
DeWalt



- Hammer truck provides easy transportation of pavement breaker

Specifications:

- Impact Energy: 61 ft-lbs
- Amps: 15 Amps
- Loaded Speed (bpm): 900 bpm
- Chisel Rotation
- Includes: Hammer truck, flat foot plate for hammer truck, pegged foot plate for hammer truck, (1) bull point chisels, (1) 1" cold chisel, (1) 3" wide chisel

Item #
DTD25980K

13 AC Amp Straight Grinder

4-1/2", Heavy-Duty
DeWalt



Specifications:

- Amps: 13.0 AC Amps
- No Load Speed: 11,000 rpm
- Spindle Thread: 5/8"-11
- Switch Type: Slide
- Includes: 2-position side handle, depressed center wheel, keyless adjustable guard, wrench

Item #
DTD28131

7.0 Amp Angle Grinder

4-1/2", Heavy-Duty
DeWalt



- 120V, AC/DC
- 10,000 rpm motor provides high power and speed for all 4 1/2" grinding applications
- Spindle lock for quick and easy wheel changes
- 5/8"-11 Spindle Thread
- 7.0 amps
- Includes: 2 position side handle, depressed center wheel, keyless adjustable guard, wrench

Item #
DTD28110

4-1/2"/5" High Performance Grinder

With Trigger Grip
DeWalt



- Quick-Change wheel release provides tool free wheel removal; Keyless adjustable guard provides tool free guard adjustments increasing productivity

Specifications:

- Amps: 13.0 Amps; No Load Speed: 9,000 rpm
- Spindle Lock: Yes; Spindle Thread: 5/8"-11
- Includes: 2-position side handle, 5" keyless adj. guard, wrench

Item #	Desc.
DTD28115	With Lock on Trigger Grip

13 Amp 4-1/2" Angle Grinder

11,000rpm
DeWalt

- 3.0 Amp/ 11,000 rpm
- Dust Ejection System™
- Keyless adjustable guard provides tool free guard adjustments increasing productivity
- Includes: 2 position side handle, depressed center wheel, wrench



Item #
DTD28114

4-1/2" Small Angle Grinder

Heavy-Duty
DeWalt

- 10.0 Amp AC/DC 11,000 rpm motor
- Dust Ejection System(TM); Quick-Change(TM) Wheel Release

Specifications:

- No load speed: 11,000 rpm; Use wheels RPM above: 12,000 rpm
- Spindle lock: yes; Spindle thread: 5/8"-11
- Includes: 2 position handle, depressed center wheel



Item #
DTD28402

12 Amp 5" Angle Grinder

Heavy-Duty
DeWalt

- 10,000 rpm motor provides high power and speed for all 5" grinding applications
- 120V AC/DC capacity works off welding machines and generators
- 5/8"-11 Spindle Thread
- Includes: 2 position side handle, 5" guard, wrench



Item #
DTDW831



High Performance Grinder

5"/16", w/Trigger Guard

DeWalt

- Dust Ejection System™; Quick-Change™ Wheel Release

Specifications:

- Amps: 13.0 AC/DC Amps; No Load Speed: 9,000 RPM
- Spindle Thread: 5/8"-11
- Includes: 2-position side handle, 5" keyless adjustable guard, 6" keyless adjustable guard, wrench



Item #

DTD28065

6" High Performance Cut-Off Grinder

DeWalt

Specifications:

- Amps: 13.0 AC Amps; No Load Speed: 9,000 RPM
- Spindle Thread: 5/8"-11; Switch Type: Paddle w/ lock-on
- Includes: 2-position side handle, Type 27 depressed center wheel, Type 27 keyless adjustable guard, Type 1 cutting wheel, Type 1 keyless adjustable guard, wrench



Item #

DTD28144

6" High Performance Cut-Off Grinder

DeWalt

Specifications:

- Amps: 13.0 AC Amps; No Load Speed: 9,000 RPM
- Spindle Thread: 5/8"-11; Switch Type: Slide
- Includes: 2-position side handle, Type 27 depressed center wheel, Type 27 keyless adjustable guard, Type 1 cutting wheel, Type 1 keyless adjustable guard, wrench



Item #

DTD28140

15 Amp 7" Angle Grinder

Heavy-Duty

DeWalt

- 6,000 RPM motor provides high power and speed for all 7" grinding applications
- Spindle lock for quick and easy wheel changes; 5-11 Spindle thread



Item #

DTD28499X

7" Large Angle Grinder

8,000 RPM - with Guard & Wheel

DeWalt

Specifications:

- Spindle Lock; 2 Finger switch
- 7" Keyless Guard & Wheel Included



Item #

DTD28474W

13 Amp 7" Angle Grinder

Heavy-Duty

DeWalt

Specifications:

- 120V AC/DC
- 8000 RPM No Load Speed
- Spindle lock; 5/8"-11 Spindle Thread



Item #

DTDW840

9" Large Angle Grinder

DeWalt

Specifications:

- Amps: 15.0 AC/DC Amps; No Load Speed: 5,000 rpm
- Spindle Lock: Yes; Spindle Thread: 5/8"-11
- Includes: 9" guard, 5 position side handle



Item #

DTD28493N

Grinder Pad Attachment

Rubber Backing

DeWalt

High quality raw materials.

- 6-1/2"; 8,500 max rpm



Item #

DTDW4947

3 Amp Straight Grinder

1-1/2", Heavy-Duty

DeWalt

- 25,000 RPM
- Motor provides high power and speed for all 1-1/2" grinding applications
- 120V AC/DC capacity works off welding machines and generators for increased productivity and versatility



Item #

DTDW887



5 Amp Straight Grinder

2", Heavy-Duty
DeWalt

- 19,000 RPM
- Motor provides high power and speed for all 2" grinding applications
- 120V AC/DC capacity works off welding machines and generators for increased productivity and versatility



Item #

DTDW888

4 Amp Bench Grinder

Heavy-Duty, 6"
DeWalt

- Powerful 5/8 HP induction motor for heavy-duty grinding operations
- Industrial cast iron base and motor housing provide durability and prolong life



Specifications:

- Motor runs at 3,450 rpm for high speed material removal
- Amps (AC): 4.0
- No Load Speed: 3,450 rpm
- Wheel Diameter: 6 in.
- Spindle Diameter: 1/2 in.

Item #

DTDW756

4.2 Amp Bench Grinder

Heavy-Duty, 8"
DeWalt

- 3/4 HP induction motor provides superior power for industrial grinding applications



Specifications:

- Amps: 4.2 AC
- No Load Speed: 3,600 rpm
- Wheel Diameter: 8 in.
- Spindle Diameter: 5/8 in.

Item #

DTDW758

Variable Speed Polisher

7"/9"
DeWalt



- Variable speed dial allows user to vary speed for specific materials and various applications (100-350 spm)

Specifications:

- Amps: 7.0 AC Amps
- No Load Speed: 0-1,750 rpm
- Spindle Thread: 5/8"-11
- Spindle Lock: Yes
- Includes: Side handle, rubber backing pad

Item #

DTDW847

8 Amp Electronic Variable Speed Polisher

Heavy-Duty, 7"/9"
DeWalt



- Electronic module maintains specified speed even under load
- Conveniently located variable speed dial lets user set maximum speed from 1,000 to 3,000 for different materials and applications
- Variable speed trigger allows user to instantly control speed from 0 to dialed setting

Specifications:

- Amps: 8.0 AC
- No Load Speed: 0-1000/0-3000 rpm
- Spindle Thread: 5/8 - 11 in.
- Spindle Lock: Yes
- Includes: Side handle, rubber backing pad

Item #

DTDW849

Deep Cut Band Saw Kit

DeWalt



- Industry best 5" deep cut capacity for round or rectangular stock
- LED sight light
- Integrated hang hook
- Variable speed dial

Specifications:

- Amps: 10 AC Amps
- Ft./Min.: 100-350 fpm
- Max Capacity (Round): 5"
- Max Capacity (Rectangular): 5" x 4-3/4"
- LED Light: Yes
- Includes: Case, blade

Item #

DTDWM120K



6.5 Amp Heavy-Duty Shears

12 Gauge
DeWalt

Heavy-duty 12 Gauge Shear

- Paddle switch for convenient operation
- Four-edge blade design provides four times the life of standard blades
- Cuts radius as small as 1"
- Amps 120V AC/DC: 6.5
- Strokes/Min.: 1,950
- Cutting Speed (ft./min.): 26-39
- Capacity Mild Steel (ga.): 12
- Capacity Stainless Steel (ga.): 14



Item #
DTDW893

3 Amp Heavy-Duty Nibblers

16/18 Gauge
DeWalt

- No Load Speed 2100 SPM
- Round punch allows 360° pivot while cutting
- Rotating head allows changing cutting directions as desired
- Mild Steel: 16 ga
- Stainless Steel: 18 ga



Item #
DTDW896

14" Chop Saw

15 AMP, 5.5 HP
DeWalt

- Powerful 15.0 Amp motor provides more overload capacity, increasing performance and durability
- Quick-Change Blade Change System increases productivity
- Ergonomically designed "D" handle
- Large cutting capacity (5" round / 4-1/2" x 6-1/2" rectangle) provides the ability to cut a wide variety of materials

Specifications:

- 4,000 RPM
- Spindle lock and Quick lock device
- Includes: Blade, wrench



Item #
DTD28715

14" Chop Saw

15 AMP, 4.0 HP
DeWalt

- 15.0 Amp motor provides overload protection, increasing performance and durability
 - Ergonomically designed horizontal "D" handle
 - Quick-lock vise allows for fast clamping
- Specifications:

- 3800 no load speed
- Spindle lock
- Quick lock vise
- Wheel arbor 1"
- Wheel dia. 14"
- Includes: Blade, wrench



Item #
DTD28700

5 Amp Cut-Out Tool

Heavy-Duty
DeWalt

- Tool-free bit change
- Removable shoe
- Turn-on, bump-off switch
- Accepts 1/8" and 1/4" shank cut-out bits
- Amps: 5.0
- No Load Speed (rpm): 30,000
- Collets (in.): 1/4 and 1/8



Item #
DTDW660

4.3 Amp Random Orbit Sanders

6", Right Angle
DeWalt

- Controlled Finishing System™ maintains controllable pad speed and minimizes gouging
- Paper Size/Type: 6", 6-hole Hook and Loop™

Specifications:

- Amps: 4.3
- OPM: 4,300 - 6,800
- Includes: Dust bag



Item #
DTDW443



Palm Grip Sander

1/4 Sheet
DeWalt

- Textured anti-slip top and body grip provides ultimate comfort and control during use
- Dust-Sealed Switch
- High capacity dust bag with built-in vacuum adapter



Specifications:

- Amps: 2.4 Amps
- Orbits/Min: 14,000 opm; Orbit Diameter: 1/16"
- Paper Size/Type: 1/4 Sheet
- Includes: Dust bag with vacuum adapter, sandpaper punch

Item #

DTD26441

Random Orbit Sander Kit

5"
DeWalt

- High capacity dust bag with built-in vacuum adapter
- Accepts 5", 8-hole hook & loop paper



Specifications:

- Amps: 3.0 Amps
- Orbits/Min: 12,000 opm; Orbit Diameter: 3/32
- Paper Size/Type: 5", 8-hole hook & loop
- Includes: Dust bag with vacuum adapter, case

Item #

DTD26451K

3"x21" Belt Sander

DeWalt

- Three wheel design delivers lowest center of gravity and longest 3" X 21" platen available
- Dust collection shut-off valve eliminates dust stream toward user when collector is not in use



Specifications:

- Amps: 8.0: Amps
- Paper Size/Type: 3" x 21"
- SFPM: 1,400
- Includes: Sanding belt

Item #

DTDW432

3"x21" Variable Speed Belt Sander

DeWalt

- Three wheel design delivers lowest center of gravity and longest 3" x 21" platen available
- Variable speed dial allows user to vary speed for specific materials and various applications (100-350 spm)
- Dust collection shut-off valve eliminates dust stream toward user when collector is not in use



Specifications:

- Amps: 8.0: Amps
- Paper Size/Type: 3" x 21"
- SFPM: 8,500 - 1,400
- Includes: Sanding belt, dust bag

Item #

DTDW433

Fixed Base Router

1-3/4 HP (Maximum Motor HP)

DeWalt

- 1-3/4 HP (maximum motor HP), 11.0 Amp motor provides the power to rout smoothly through the toughest hardwoods
- Micro-fine depth adjustment ring provides precise depth adjustments in 1/64" increments and adjusts vertically for a constant switch/cordset location
- Clear, Lexan sub-base provides enhanced base durability, bit visibility



Specifications:

- Amps: 11.0 Amps; No Load Speed: 24,500 rpm
- Collet Diameter: 1/2", 1/4"
- Base Dimension: 6"

Item #

DTDW616

10 Amp Electronic Plunge Routers

Heavy-Duty, 2HP

DeWalt

- Full wave electronic variable speed motor with soft start runs at 8000-24000 rpm with constant speed under load to ensure quality finish in all materials
- Rack and pinion depth adjuster, with micro-fine adjusting allows quick, accurate set ups
- Only plunge router with built-in dust extraction through the column, removes 95% of the dust



Specifications:

- Amps: 10.0; Horsepower: 2 HP
- No Load Speed: 8,000-24,000 rpm
- Collet Diameter: 1/4", 1/2" Plunge Stroke: 2-1/8"
- Spindle Lock: Yes

Item #

DTDW621



15 Amp Heavy-Duty Router

3 HP
DeWalt



- 15 Amp 120V motor uses state of the art circuitry for soft starts and smooth operation
- Electronic variable speed motor runs at 8,000-22,000 rpm with constant speed under load to ensure a quality finish in all materials
- 8000 to 22,000 RPM no load speed
- 2-7/16 Plunge Stroke

Item #
DTDW625

Fixed Base / Plunge Router Combo Kit

1-3/4 HP (Maximum Motor HP)
DeWalt



- Micro-fine depth adjustment ring provides precise depth adjustments in 1/64" increments and adjusts vertically for a constant switch/cord-set location

Specifications:

- Amps : 11.0 Amps
- Horsepower: 1-3/4 HP
- No Load Speed: 24,500 rpm
- Collet Diameter: 1/2", 1/4"
- Plunge Stroke: 2-1/2"
- Depth Stop: Micro-fine depth adjustment ring
- Base Dimension: 6"
- Includes: Fixed base, plunge base, case, 1/4" and 1/2" collets, wrench

Item #
DTDW616PK

6.5 Amp Plate Joiner Kit

Heavy-Duty
DeWalt



- 6 tooth carbide blade
- Motor provides power for the hardest woods
- Dual rack and pinion fence ensures blade and fence are always parallel, for accurate joints every time
- Retractable, anti-slip pins help hold work in place
- Preset depth stops for all common biscuit sizes

Item #
DTDW682K

Palm Nailer

Lightweight
DeWalt



- Lightweight, compact design (Only 2.65 lbs.)
 - Will drive all jobsite required fasteners (6d - 16d bulk nails)
 - Magnetic tip for easy nail placement
- Specifications:
- Nail Diameter: 6d-16d gauge

Item #
DTD51180



MILWAUKEE ELECTRIC TOOL CORP.

1/2" High Performance Drill Driver Kit

M18™ Cordless



- Peak Torque: 650 in-lbs
- RPM: 450/1,800
- Chuck Type: 1/2" Metal Single Sleeve w/ Carbide Jaws
- Length: 9-1/4"
- 5 Year Warranty
- Includes: (2) M18™ XC High Capacity Lithium-Ion Batteries, 1-Hour Charger, Side Handle, Carrying Case

Item #
MI2610-24

MILWAUKEE ELECTRIC TOOL CORP.

Volt Hammer Drill Kit With Impact Driver

M18™



- 18V XC High Capacity Lithium-ion battery delivers longer life and run-time
- Variable speed trigger

Hammer Drill:

- 1/2" single sleeve ratcheting metal chuck with carbide jaws
- On-board Battery Fuel Gauge displays remaining run-time
- Built-in LED light illuminates work surface
- Includes: (2) M18 Lithium-Ion batteries, charger, side handle, case

Item #
MI2611-24



MILWAUKEE ELECTRIC TOOL CORP.
1/4" Hex Compact Impact Driver Kit

M18™ Cordless

- Torque: 1,400 in lbs.
- RPM: 0-2,200; IPM: 0-3,200
- 18V XC High Capacity Lithium-Ion battery
- 1/4" Hex Quick Change Chuck
- Milwaukee® 4-Pole Frameless Motor
- Battery Fuel Gauge displays remaining run-time
- Built-in LED Light
- Includes: Driver, (2) 18V XC LITHIUM-ION Batteries, Charger, Belt Clip, Carrying Case



Item #
MI2650-22

MILWAUKEE ELECTRIC TOOL CORP.
1/2" High Torque Impact Wrench Kit

M18™ Cordless

The M18™ Cordless Lithium-Ion 1/2" High Torque Impact Wrenches provide industry leading power in a compact size. Built with a Milwaukee® 4-pole motor and a powerful impact mechanism, the 2662-22 and 2663-22 deliver 450 ft-lbs of torque. A variable speed trigger provides speed control between 0-1900 RPM & 0-2200 IPM. The 2662-22 has a 1/2" anvil with detent pin to achieve superior socket retention, while the 2663-22 has a 1/2" anvil with friction ring for quick and easy one-handed socket changes.



- Milwaukee® Designed Impact Mechanism: Delivers 450 ft- lbs of torque
- Compact Size Lightweight: 8-7/8" Length and 6.7 lbs
- Milwaukee® 4-Pole Frameless Motor: Delivers maximum run-time
- 1/2" Anvil w/Friction Ring: Provides quick and easy, one-handed socket changes

Includes:

- (2) M18™ XC High Capacity Lithium-Ion Batteries, 1-Hour Charger, Carrying Case

Item #	Peak Torque (ft/lbs)	RPM/IPM	Anvil	Weight (lbs.)	Length
MI2663-22	450	1900/2200	1/2" Friction Ring	6.7	8 7/8

MILWAUKEE ELECTRIC TOOL CORP.
Compact Drill Driver Kit

M18™ Cordless

- 1/2" Ratcheting chuck with plastic sleeve
- Heavy-duty 2-speed metal gear box: 0-350/0-1,400 rpm
- Compact length (7-3/4 in.) fits in tight areas
- Compact motor delivers 400 in.-lbs. of maximum torque
- Built-in LED light illuminates work surfaces
- Belt Hook frees up both hands for work positioning before fastening
- Lightweight 4.0 lbs.
- Voltage: 18 DC
- Chuck Size: 1/2 in.
- No Load Speed: 0-350/0-1,400 RPM
- Torque: 400 in.-lbs.
- Chuck Type: Keyless
- Reversible Battery: No
- No. of Batteries Included: 2
- Amp Hours: 1.4
- Spindle Lock: Yes
- Clutch Settings: 21
- Capacity in Steel: 1/2 in.
- Capacity in Wood: 1 in.
- Length: 7-3/4 in.
- Includes: Two batteries, charger, carrying case



Item #	Peak Torque (in/lbs)	RPM	Chuck Type	Weight (lbs.)	Length (in.)
MI2601-22	400	350/1400	1/2" Single Sleeve	3.9	7 3/4

MILWAUKEE ELECTRIC TOOL CORP.
Expansion Tool Kit

M18™ Cordless Propex®

- Speed: 45 SPM
- Head Rotation: Built-In Auto-Rotator
- Capacity: 3/8" - 1-1/2"
- Compatibility: 3/8" - 1" M12™, 1" - 1-1/2" M18™/Uponor®
- LED Light
- 5 Year Warranty
- Includes: (2) M18™ Compact Lithium-Ion Batteries, 30-Minute Charger, 1" Expansion Head, 1-1/4" Expansion Head, 1-1/2" Expansion Head, Grease, Carrying Case



Item #
MI2632-22



MILWAUKEE ELECTRIC TOOL CORP.

Band Saw Kit

M18™ Cordless



- SFPM: 480
- Capacity: 3-1/4" x 3-1/4"
- Weight: 10.25 lbs.
- Material Guide: Tool-Free
- Blade Ejection System
- 5 Year Warranty
- Includes: (2) M18™ XC High Capacity Lithium-Ion Batteries, 1-Hour Charger, Blade, Carrying Case

Item #
MI2629-22

MILWAUKEE ELECTRIC TOOL CORP.

Recip Saw Kit

M18™ Cordless Sawzall®



Truly an over achiever, this cordless Lithium-Ion Sawzall® powered by an 18V XC High Capacity Redlithium™ battery offers up to 75 more cuts per charge and is designed to cut up to 30% faster with less vibration. The Sawzall® M18™ Cordless Lithium-Ion Recip Saw features a patented gear-protecting clutch, which absorbs impact and extends the life of the tool. The Quik-Lok™ blade clamp provides quick and efficient blade changes while the variable speed trigger optimizes speed for different applications. Weighing only 7.9 lbs., the saw is designed for maximum power, operator comfort and convenience, including an on-board fuel gauge that displays the remaining run-time.

- 18V XC High Capacity Redlithium™ battery delivers longer life and run-time
- Patented Gear-Protecting Clutch extends the life of the tool
- Lever Action Quik-Lok™ Blade Clamp
- Battery fuel gauge displays remaining run-time
- Variable Speed Trigger
- Includes: Sawzall® M18™ Cordless Lithium-Ion Recip Saw, (2) 18V XC High Capacity Redlithium™ battery (48-11-1828), 18V Charger (48-59-1801), (1) General Purpose Sawzall® Blade, Carrying Case

Item #	Stroke Length (in.)	Strokes/Min.	Length (in.)	Tool Wt. (lbs.)
MI2620-22	1	0-3200	17¾	7.9

MILWAUKEE ELECTRIC TOOL CORP.
Lithium-Ion ProPex®
Expansion Tool - Bare Tool



M18™ Cordless

- Features an auto-rotating head for convenient one-handed operation
- Speed: 45 spm
- Capacity: 3/8" - 1-1/2"

Features:

- Built-in Auto Rotate Mechanism for Effortless, One-Handed Use
- "D"-Handle Design for Added Durability from Impact
- LED Work Light Illuminates Work Space in Dark Locations
- Battery Fuel Gauge Displays Remaining Run-Time
- Compatible with Both Compact and XC M18™ Redlithium™ Batteries

Specifications:

- Voltage: 18V
- Expander Mechanism: Quick Cam w/ Quick Return
- Auto-Rotation: Built-In
- LED Light: Yes
- Battery Fuel Gauge: Yes

Item #
MI2632-20

MILWAUKEE ELECTRIC TOOL CORP.

Compact Lithium-Ion Battery

M18™ Cordless

- 1.4 amp-hour
- Battery Type: Lithium-Ion
- 2 Year Warranty



Item #
MI48-11-1815

MILWAUKEE ELECTRIC TOOL CORP.

XC High Capacity Lithium-Ion Battery

M18™ Cordless

- 3.0 amp-hour
- Battery Type: Lithium-Ion
- 5 Year Warranty



Item #
MI48-11-1828



MILWAUKEE ELECTRIC TOOL CORP.
Lithium-Ion 6-1/2" Circular Saw

M18™ Cordless

- Heavy-Duty Magnesium Guards
- Electronic brake; Aircraft aluminum shoe
- Battery fuel gauge displays remaining run-time
- Voltage: 18V
- Battery: 18V XC High Capacity Lithium-Ion Battery
- Speed: 3,500 RPM
- Arbor: 5/8"; Blade: 6-1/2" 24T Carbide Tipped
- Includes: (2) 18V XC High Capacity Lithium-Ion Battery Packs, 1-Hour Charger, Contractor Bag



Item #

MI2630-22

MILWAUKEE ELECTRIC TOOL CORP.
Lithium-Ion Work Light

M18™ Cordless

- Ergonomic, compact, and lightweight design for operator comfort
- Fold-away utility hook; 135 degree rotating head
- Utilizes both the 18V Compact Redlithium™ battery and the 18V XC High Capacity Redlithium™ battery to provide longer run-time
- Features a Xenon incandescent bulb



Item #

MI49-24-0171

MILWAUKEE ELECTRIC TOOL CORP.
Power-Plus Batteries

Heavy-Duty

- 18 volt, 2.4 A-H
- Delivers the most run time, is compatible with 18 volt Milwaukee tools and work lights



Item #

MI48-11-2230

MILWAUKEE ELECTRIC TOOL CORP.
Lithium-Ion Battery Charger

M18™

- Charge Time: (48-11-1815) 30 minutes, (48-11-1828) 1-hour
- 5 Year Warranty



Item #

MI48-59-1801

MILWAUKEE ELECTRIC TOOL CORP.
Lithium-Ion AC/DC Wall and Vehicle Charger

M18™

Dual function design:

- AC Wall Charger and DC Vehicle Charger quickly charges all M18™ batteries:
- 48-11-1815 - 30 minute charge time
- 48-11-1828 - 1 hour charge time

Charger communicates with battery pack to manage:

- Individual Cell Voltage; Temperature; Charge Status



Item #

MI2710-20

MILWAUKEE ELECTRIC TOOL CORP.
Battery Charger

18V-28V Universal

- Milwaukee's Universal Charger charges both Lithium-Ion And NiCd Milwaukee Batteries From 18V to 28V
- High visibility LED light displays charge status from across the room
- Charges Li-Ion Batteries in 1 hour or less; Charges NiCd Batteries in 40 minutes or less



Item #

MI48-59-2818

MILWAUKEE ELECTRIC TOOL CORP.
Lithium-Ion Screwdriver

M12™ Cordless

- Quick Bit-Loading 1/4 in. Hex Chuck
- Battery Fuel Gauge for displaying remaining run-time; Built-in LED for illumination of dark work spots
- Variable Speed Trigger; Over-mold Side and Grip for secure grip and work surface protection
- Includes: 2401 M12™ Cordless Lithium-Ion Screwdriver, (2) 12V Redlithium™ Batteries (48-11-2401), 12V Charger (48-59-2401), Compact Driver Storage Bag (48-55-2401)



Item #

Desc.

MI2401-22

Subcompact Impact Driver Kit

MILWAUKEE ELECTRIC TOOL CORP.
Lithium-Ion 1/4" Hex Impact Driver

M12™ Cordless

- 12V Redlithium™ battery offers longer run-time and lighter weight; Battery Fuel Gauge displays remaining run-time
- 0-2,000 RPM variable speed trigger; Built-in LED Light
- Includes: 2450-22 M12™ Cordless Lithium-Ion™ Hex Impact Driver, (2) 12V Redlithium™ Batteries 48-11-2401, 12V Charger 48-59-2401, Carrying Case



Item #

MI2450-22



MILWAUKEE ELECTRIC TOOL CORP.
3/8" Drill Driver Kit

M12™ Cordless

The M12™ Cordless Lithium-Ion 3/8" drill driver delivers 250 in-lbs of torque in a compact light weight design. The only tool in its class with an all metal locking chuck, the 2410-22 drills and fastens up to 35% faster than the competition. The on board fuel gauge displays remaining run-time, while a built in LED illuminates work surface.



- 2-Speed all metal gear box - up to 35% faster drilling/fastening and Milwaukee durability
- Powerful Motor: Delivers 250 in/lbs of torque - Up to 25% more torque
- 3/8" Single sleeve ratcheting metal chuck - increased bit retention and durability
- Lightweight and compact - tool belt portable at only 2.5 lbs. and 7-3/8"
- Integrated LED and fuel gauge - increased productivity and decreased frustration
- Includes: (2) M12™ Lithium-Ion batteries, 30-minute charger, carrying case

Item #	Peak Torque (in/lbs)	RPM	Chuck Type	Length (in.)	Weight (lbs.)
MI2410-22	250	0-400/0-1500	3/8" Metal Single Sleeve	7 3/8"	2.5

MILWAUKEE ELECTRIC TOOL CORP.
Lithium-Ion Multi-Tool Kit

M12™ Cordless

The M12™ Cordless Lithium-Ion Multi-Tool is one of the most versatile jobsite tools. This 12V cordless oscillating tool is ideal for remodelers, flooring contractors, maintenance repair technicians, and electricians that tackle awkward applications on jobsites. The M12™ Cordless Lithium-Ion Multi-Tool runs 5,000 to 20,000 OPM and allows the user to match the speed to the application. The 12V Oscillating Tool has the versatility to perform a variety of applications; flush or plunge cuts, removing grout or grinding thinset, sanding or scraping. In addition, the new M12™ Redlithium™ battery and Milwaukee's M12™ XC Lithium-Ion battery provide additional run time for the user. The universal adaptor (included in each kit) allows the M12™ Cordless Lithium-Ion to be compatible with most competitive accessories on the market today.



- Application Versatility: Cuts, grinds, sands and scrapes
- Compatible: M12™ Lithium-Ion System with over 25 cordless tools
- Accessory Adaptor (Included): Compatible with most competitive accessories
- Run Time: Redlithium™ batteries offer extended run time
- Durability: All metal gear case
- Variable Speed Dial: Match speed to application
- On board Fuel Gauge: Displays remaining run time
- Includes: 2426 M12™ Cordless Lithium-Ion Multi-Tool, Adapter, Wood Cutting Blade, Sanding Pad, (5) Assorted Sanding Sheets, (2) M12 Redlithium™ Batteries, 30-Minute Charger and Contractor Bag

Item #	Variable Speed	OPM	Length (in.)	Tool Wt. (lbs.)
MI2426-22	12 Settings	5000-20000	10 7/8"	2.1



MILWAUKEE ELECTRIC TOOL CORP.
**Lithium-Ion ProPEX®
Expansion Tool Kit**



M12™ Cordless

- Built-in Auto Rotate Mechanism for Effortless, One-Handed Use
- Compact, Right Angle Design for Use in Tight Locations
- Paddle Trigger for Easy Reach in Confined Spaces; LED Work Light
- Battery Fuel Gauge Displays Remaining Run-Time; Compatible with Both Compact and XC M12™ Lithium-Ion Batteries
- Includes: 2432 M12™ Cordless Lithium-Ion ProPEX® Expansion Tool, (2) M12™ RedLithium™ Batteries, 30-Minute Charger, 1/2", 3/4", 1" Heads, Grease, Carrying Case

Item #
MI2432-22

MILWAUKEE ELECTRIC TOOL CORP.
Lithium-Ion Recip. Saw

**M12™ Cordless
Hackzall™**



- Only 11" and 2.6 lbs. for cutting in tight spaces
- Keyless Quik-Lok™ Blade Clamp allows for quick and easy blade changes
- Variable Speed Trigger
- Battery Fuel Gauge displays remaining run-time
- Accepts both Hackzall™ and Sawzall® style blades
- 12V Lithium-Ion Battery; Built-In LED Light
- Includes: 2420-20 Hackzall™ M12™ Cordless Lithium-Ion Recip. Saw, (2) 12V Lithium-Ion Batteries (48-11-2401) Packs, 30-Minute Charger (48-59-2401), (2) Hackzall™ Blades, Carrying Case

Item #
MI2420-22

MILWAUKEE ELECTRIC TOOL CORP.
Detection Tool Kit



**M12™ Cordless
Sub-Scanner™**

- Detects Rebar in Concrete
- Depth (Metal): 6"; Depth (Wood, Metal Stud): 1-1/2"
- Stud Edges & Center
- 5 Year Warranty
- Includes: (1) M12™ Lithium-Ion Battery Pack, 30-Minute Charger, Carrying Case, Manual

Item #
MI2290-21

MILWAUKEE ELECTRIC TOOL CORP.
Digital Multimeter



The Milwaukee Digital Multimeter is a heavy-duty True-RMS meter for professional residential, commercial and industrial applications. The perfect tool for the professional electrician, the 2217-20 offers rugged over-molding for increased durability and grip, a large white on black display for clearer readings, a slide rail system to add proprietary accessories and over-molded dial for easy one handed use. In addition, the new model meets the safety specifications required by the electrical user. Covered by Milwaukee 5-Year Warranty.

- Wide Voltage range to 600 volts AC/DC
- Auto Range to millivolts
- True-RMS for accurate measurement in all applications
- Lo-Z measurement to eliminate ghost voltage
- Frequency measurements from 10Hz to 50kHz
- Contact temperature measurement from -40 to 752°F
- Current Measurement to 10 amps AC/DC
- High Contrast, White on Black Display with Backlight for easy reading
- Rugged over-molding increases durability and user grip
- Includes: Electrical Test Lead Set, Dual Banana Thermocouple, (2) AA Batteries, Manual

Item #	Voltage Range	Safety Rating	Current Range	Contact Temp. Range
MI2217-20	6mV to 600V AC 600mV to 600V DC	CAT III 600V	0.040A to 10.00A AC/DC	-40° F to 752° F

MILWAUKEE ELECTRIC TOOL CORP.
Fork Meter



Alkaline Battery

- Current Range: 200A AC
- Voltage Range: 1,000V AC/DC
- Lo-Z
- Safety Rating: CAT IV 600V/CAT III 1,000V
- Fork Opening: 0.63"
- TRMS
- 5 Year Warranty
- Includes: Electrical Test Lead Set, (2) AA Batteries, Manual

Item #
MI2205-20



MILWAUKEE ELECTRIC TOOL CORP.
Clamp Meter

The Milwaukee Clamp Meter is a heavy duty True-RMS electrical current tester for professional residential, commercial, and industrial applications. The perfect tool for the professional electrician, the 2237-20 Clamp Meter provides a wide 1.3" jaw opening to easily handle large conductors, a thin jaw profile for access to tight spaces and a high contrast white-on-black display for clearer readings. In addition, the Milwaukee Clamp Meter was designed with embedded non-contact voltage detection and an LED work light to increase end user productivity. Covered by Milwaukee 5-Year Warranty.



- Measures up to 600 amps AC/DC, Large 1.30" jaw opening; Thin Jaw Profile for easier wire measurement in panels or in bundles
- Wide Voltage range to 600 AC/DC volts; True-RMS for accurate measurement in all applications
- Built-In Voltage Detector and LED Work Light; Frequency Measurement
- High Contrast, White on Black Display with Backlight for easy reading; Rugged over-molding increases durability and user grip
- CAT III 600V for increased safety
- Includes: Electrical Test Lead Set, (2) AA Batteries, Manual

Item #	Current Range	Voltage Range	Safety Rating
MI2237-20	600A AC/DC	600V AC/DC	CAT III 600V

MILWAUKEE ELECTRIC TOOL CORP.
Clamp Meter for HVAC/R

The Milwaukee Clamp Meter for HVAC/R is a heavy-duty True-RMS electrical current tester for professional residential, commercial, and industrial applications. The perfect tool for the professional HVAC/R technician, the 2236-20 Clamp Meter provides a wide 1.3" jaw opening to easily handle large conductors, a thin jaw profile for access to tight spaces and a high contrast white-on-black display for clearer readings. In addition, the Milwaukee Clamp Meter for HVAC/R was designed with embedded non-contact voltage detection and an LED work light to increase end user productivity. Covered by Milwaukee 5-Year Warranty.



- Measures up to 600 amps AC, Large 1.30" jaw opening; Thin Jaw Profile for easier wire measurement in panels or in bundles
- Wide Voltage range to 600 AC/DC volts
- True-RMS for accurate measurement in all applications; Built-In Voltage Detector and LED Work Light
- Thermocouple (dual banana) input for contact temperature measurement; 600 uA DC for Flame Rectification
- High Contrast, White on Black Display with Backlight for easy reading; Rugged over-molding increases durability and user grip
- Includes: Electrical Test Lead Set, Dual Banana Thermocouple, (2) AA Batteries, Manual

Item #	Current Range	Voltage Range	Safety Rating	Contact Temp. Range
MI2236-20	600A AC	600V AC/DC	CAT III 600V	-40° F to 752° F

MILWAUKEE ELECTRIC TOOL CORP.
Laser Distance Meter

Alkaline Battery

- Distance Range: 0.16' (0.05m) to 197' (60m)
- Basic Accuracy: $\pm 0.059"$ ($\pm 1.5\text{mm}$)
- Display Resolution: 000' 00 in 1/8, 000.00', 00.000 m
- Arithmetic Functions
- 5 Year Warranty
- Includes: (2) AAA Batteries, Carrying Case, Manual



Item #
MI2280-20

MILWAUKEE ELECTRIC TOOL CORP.
Laser Temp-Gun™

- Temperature Range: -20° F to 932° F
- Basic Accuracy: 1.50%
- Distance to Spot: 12 to 1
- Contact Temperature Range: -22° F to 842° F
- 5 Year Warranty
- Includes: (3) AA Batteries, Manual



Item #
MI2266-20

MILWAUKEE ELECTRIC TOOL CORP.
Lithium-Ion Copper Tubing Cutter

M12™ Cordless

- Close quarter rotating cutting head cuts pipe in confined spaces
- Automatic adjustment from 3/8" - 1" tubing
- Auto Locking Mechanism delivers up to 200 cuts per charge
- Battery Fuel Gauge displays remaining run-time
- Built-in LED
- 12V Lithium-Ion battery
- Includes: 2471 M12™ Cordless Lithium-Ion Copper Tubing Cutter, (2) 12V Lithium-Ion Batteries, 30-Minute Charger, Carrying Case



Item #
MI2471-22



MILWAUKEE ELECTRIC TOOL CORP.

Lithium-Ion Digital Inspection Camera

*M12™ Cordless
M-Spector™*

- Digital technology delivers superior image quality
- Large, 2.4", high-resolution (320X240) color LCD display; Exclusive adjustable image zoom (2x)
- 3 Stage LED Brightness Control w/ Digital Glare Reduction
- Up front camera controls for true one-hand operation
- Rugged, detachable 3' water-tight flexible shaft; Small camera head and shaft diameter fit into holes as small as 3/4"
- 3' extension cables (Recommended maximum extension is 9')
- Model 2310-21 Includes 12V Lithium-Ion battery, 30-min charger, hard case



Item #

MI2310-21

MILWAUKEE ELECTRIC TOOL CORP.

Compact Lithium-Ion Battery

M12™ Cordless

- Battery Type: Compact Lithium-Ion
- 2 Year Warranty



Item #

MI48-11-2401

MILWAUKEE ELECTRIC TOOL CORP.

XC High Capacity Lithium-Ion Battery

M12™ Cordless

- Battery Type: Lithium Ion
- 2 Year Warranty
- Over-molded Base



Item #

MI48-11-2402

MILWAUKEE ELECTRIC TOOL CORP.

Lithium-Ion Battery Charger

M12™

- Charge Time: (48-11-2401) 30 minutes, (48-11-2402) 1-hour
- 5 Year Warranty



Item #

MI48-59-2401

MILWAUKEE ELECTRIC TOOL CORP.

Lithium-Ion 28 Volt 1/2 in. Hammer-Drill

M28™ Cordless

- 1/2" all-metal, single-sleeve, ratcheting chuck with all carbide jaws; Up to 2x run-time of 18V tools
- 600 in.-lbs. of maximum torque
- Chuck type: keyless, metal
- Amp hours: 3.0, Clutch settings: 20, Capacity in steel: 1/2"; Capacity in wood: 2-9/16"; Length: 10-1/2"
- Includes: (2) M28 Lithium-Ion batteries, charger, side handle, case



Item #

MI0726-22

MILWAUKEE ELECTRIC TOOL CORP.

Lithium-Ion 1/2" Impact Wrench Kit

M28™ Cordless

- 325 ft. lbs. of maximum torque
- Variable speed: 0-1450 rpm, 0-2450 ipm
- Up to 2x run-time of 18V tools
- Torque: 3,900 in.-lbs./325 ft.-lbs.
- No load Speed: 0-1,450 RPM
- No load BPM: 0-2,450
- Includes: Two 28V batteries, one hour charger, carrying hanger bracket, quick change detent kit



Item #

MI0779-22

MILWAUKEE ELECTRIC TOOL CORP.

Lithium-Ion Compact 1" SDS Rotary Hammer Kit

M28™ Cordless

- 28 Volt high power reversible motor delivers 4,700 BPM and 2.1 ft.-lbs. of impact energy
- Optimal drilling range in concrete is from 3/16" to 3/4" with a 1" solid bit capacity and 2-1/2" thin wall core bit capacity
- Includes: (2) M28 Lithium-Ion batteries, charger, case



Item #

MI0756-22

MILWAUKEE ELECTRIC TOOL CORP.

Lithium-Ion 6-1/2" Circular Saw Kit

M28™ Cordless

- 4200 RPM
- Electric brake, Spindle lock
- Includes: Two 28V batteries, one hour charger, carrying case, circular saw blade, rip fence, Allen key



Item #

MI0730-22



MILWAUKEE ELECTRIC TOOL CORP.
Lithium-Ion Band Saw Kit

M28™ Cordless

- 4-3/4" x 4-3/4" capacity
- LED light
- Includes: Two 28V batteries, one hour charger, carrying case, band saw blade



Item #

MI0729-21

MILWAUKEE ELECTRIC TOOL CORP.
**Lithium-Ion Sawzall®
Reciprocating Saw Kit**

M28™ Cordless

- 0-2000/0-3000 SPM for metal or wood cutting
- Quik-Lok™ blade clamp for quick tool-free blade changes
- Keyless shoe adjustment quickly adjusts blade depth
- Includes: Two 28V batteries, One hour charger, Carrying case, Two super Sawzall® blades



Item #

MI0719-22

MILWAUKEE ELECTRIC TOOL CORP.
Work Light

M28™ Cordless

- Clip-Lok™ System ready
- Over 5-hours of run-time on a single charge
- 140° Pivoting Head



Item #

MI49-24-0185

MILWAUKEE ELECTRIC TOOL CORP.
Power-Plus Batteries

Heavy-Duty

- 14.4 volt, 2.4 A-H
- Compatible with all 14.4 volt Milwaukee tools and work lights



Item #

MI48-11-1024

MILWAUKEE ELECTRIC TOOL CORP.
4-Pc. Combo Kit

V28™ Cordless

- 1/2" Hammer-Drill with all-metal, single-sleeve, ratcheting chuck with all carbide jaws
- Sawzall® Recip saw with 1-1/8" stroke length
- 6-1/2" circular saw cuts 2 x 4's at 45°
- Includes: 28V Sawzall® Recip saw, 28V Hammer-Drill, 28V Circular saw, 28V Work light, Two 28V batteries, One hour charger, No. 2 phillips bit, Two Sawzall® blades, Circular saw blade, Rip fence, Clip-Lok™ system, Contractor bag



Item #

MI0928-29

MILWAUKEE ELECTRIC TOOL CORP.
14.4V Caulk/Adhesive Gun

With 10 oz. Carriage Kit

- Powerful 620 lbs. pushing force to dispense highest viscosity materials
- Remote speed dial and trigger switch allow for optimal bead control
- Voltage: 14.4 DC
- No Load Speed: 23 in./min.
- Carriage: 10 oz.
- Includes: One Hour NiCd AC Charger, One 14.4 Volt Battery Pack, 10 oz. Caulk Carriage, Plunger Rod for 10 oz. Caulk Carriage - Sausage Style & Tube



Item #

MI6562-21

MILWAUKEE ELECTRIC TOOL CORP.
Caulk Carriage

Quart Size

For the larger job, this quart size carriage will provide longer run time between tube changes. It fits on all 6560 and 6562 series Milwaukee cordless caulk and adhesive guns. For replacement plunger rod use Milwaukee 49-52-0650.



Item #

MI48-08-1080

MILWAUKEE ELECTRIC TOOL CORP.
Lithium-Ion Battery Pack

M28™

- 3.0 amp hour
- Fuel gauge
- Non-slip grip surface
- Born-on-date and performance optimizing circuit



Item #

MI48-11-2830



MILWAUKEE ELECTRIC TOOL CORP.
Orbital Super Reciprocating Saw
Super Sawzall®

- 13 amp Milwaukee built motor
- Orbital cutting action
- Variable speed trigger, 0-3000 SPM
- 1-1/4" stroke
- Quik-Lok™ blade clamp
- Includes: Saw, blade, case



Item #
MI6536-21

MILWAUKEE ELECTRIC TOOL CORP.
Orbital Reciprocating Saws

360° Rotating Handle
Super Sawzall®

- 360° Rotating Handle
- 13 Amp Milwaukee Built Motor
- Orbital Cutting Action
- Variable Speed Trigger, 0-3000 SPM
- 1-1/4" Stroke
- Quik-Lok™ Blade Clamp
- Dial Speed Control
- Includes: Carrying Case for 13 Amp Orbital Super Sawzall® Reciprocating Saws, Two Super Sawzall® Blades



Item #
MI6523-21

MILWAUKEE ELECTRIC TOOL CORP.
Reciprocating Saw Kit
Sawzall®

- Powerful 12 Amp Motor: Delivers 0-3,000 SPM
- 3/4" Stroke Length:
- Gear Protecting Clutch: Extends gear and motor life by absorbing high impact forces caused by blade lock-ups
- Counter Weighted Mechanism: Provides reduced vibration for smoother operation
- Quik-Lok™ Blade Clamp: Provides fast, tool-free blade changes
- Includes: Sawzall® Recip Saw, Carrying Case



Item #
MI6509-31

MILWAUKEE ELECTRIC TOOL CORP.
10-1/4" Circular Saw

- Powerful 15 Amp, 5,200 RPM Motor
- 3-13/16" Depth of Cut Capacity – Provides enough capacity to cut 4" material
- Aircraft Aluminum Shoe
- Electric Brake - increases productivity by stopping the blade in seconds
- 60° Bevel Capacity
- Includes: Circular Saw, Steel Case, Rip Fence



Item #
MI6470-21

MILWAUKEE ELECTRIC TOOL CORP.
Circular Saw Kits

Heavy-Duty
Tilt-Lok™

- Exclusive adjustable main handle - The 8-position locking handle adjusts to the cutting application for maximum comfort and control
- 15.0 Amp, 3-1/4 maximum horsepower motor
- Includes: Saw with Tilt-Lok handle, carbide blade, hex blade wrench and impact resistant carrying case



Item #
MI6390-21

MILWAUKEE ELECTRIC TOOL CORP.
5.5 Amp 1/2" Hole-Shooter Drill

Heavy-Duty
Magnum®

- Powerful 5.5 AMP motor
- Heavy-duty industrial chucks
- Trigger speed control reversing switches
- 1/2" capacity in steel, 0-850 no load rpm, double gear train



Item #
MI0234-6

MILWAUKEE ELECTRIC TOOL CORP.
7 Amp 3/8" Heavy-Duty Drill

Variable Speed

- Powerful 7.0 amp Milwaukee motor
- Variable speed control
- Capacity in Steel: 3/8"



Item #
MI0200-20



MILWAUKEE ELECTRIC TOOL CORP.
8 Amp 1/2" Heavy-Duty Drill

Variable Speed

- Powerful 8.0 amp Milwaukee motor
- Variable speed control, 0-850 RPM
- Capacity in Steel: 1/2"



Item #

MI0299-20

MILWAUKEE ELECTRIC TOOL CORP.
1 1/2" Magnum® Drill, 0-850 RPM with All Metal Chuck and Quik-Lok® Cord

- Powerful 8.0 amp motor, 0 to 850 rpm, variable speed control
- Grip strength - exclusive, all metal ratcheting chuck with carbide jaws
- All metal gear case
- 8 ft. 3-wire Quik-Lok® rubber cord
- 360° locking side handle
- Ergonomic tactile grip and two finger trigger for user comfort and balance



Item #	Length (in.)
MI0302-20	12.3

MILWAUKEE ELECTRIC TOOL CORP.
3/8" Hammer-Drills

*Heavy-Duty
Magnum®*

- Chuck Size: 3/8"
- Amps: 7.0, No Load Speed: 0-2,500 RPM, Chuck Type: Keyless, Metal



Item #

MI0201-20

MILWAUKEE ELECTRIC TOOL CORP.
1/4" Electric Pistol Drill

Magnum®

- For bits 1/4" in diameter or less, speed adds to productivity and quality of performance
- Powerful 7.0 amp motor, 0 to 4000 rpm, variable speed control
- Heavy-duty keyed chuck; Chuck Size: 1/4"
- Includes: Chuck Key with Holder



Item #

MI0101-20

MILWAUKEE ELECTRIC TOOL CORP.
1/2" Compact and Super Hole-Shooter Drills

Heavy-Duty

- Extra long switch handle and pipe handle allow maximum leverage for drilling, reaming large holes and added control
- Capacity in Steel: 1/2"; Volts: 120 VAC, Current Rating: 7.0 amps, RPM at No Load: 650, Gear Train: Double, Spindle Diameter and Thread: 5/8" - 16



Item #

MI1610-1

MILWAUKEE ELECTRIC TOOL CORP.
7 Amp 1/2" Compact Drills

Heavy-Duty

- Extra long switch handle and pipe handle allow maximum leverage for drilling, reaming large holes and added control
- Capacity in Steel: 1/2"; Volts: 120 AC Only, Amps: 7, No Load RPM: 900



Item #

MI1630-1

MILWAUKEE ELECTRIC TOOL CORP.
7 Amp 1/2" Compact

Hole-Shooter Drill

- Extra long switch handle and pipe handle afford maximum leverage for drilling or reaming large holes
- 1/2" capacity in steel, 7 amps, No Load RPM: 450, Gear Train: Triple



Item #

MI1660-6

MILWAUKEE ELECTRIC TOOL CORP.
10 Amp 3/4" Super Hole-Shooter Drills

Heavy-Duty

- Extra long switch handle and pipe handle afford maximum leverage for drilling or reaming large holes
- 3/4" capacity in steel
- 10 amps, 350 no load rpm, triple gear train



Item #

MI1854-1



MILWAUKEE ELECTRIC TOOL CORP.
1/2" Heavy-Duty Drills

Hole-Hawg®

- Reversing; 2 speed gear shift; Built-in hi-tech electronic switching and speed control components
- Power and torque, reversing, compact design for drilling between studs and joists; Triple reduction gearing handles up to 4-5/8" self-feed bits
- Capacity in Steel: 1/2"; Current Rating: 7.5 amps, RPM at No Load: 300/1200



Item #
MI1675-6
MI1676-6

MILWAUKEE ELECTRIC TOOL CORP.
1/2" Electric Right Angle Drill

Super-Hawg®

- The 1/2" Super Hawg™ has power and speed for drilling holes of all sizes in wood frame construction
- The 13 amp motor has two operating speeds of 1750 and 450 rpm with a clutch in the low gear range
- 90° left-right, Roto-Lok® handle for maximum operating comfort
- Chuck Size: 1/2"; Chuck Type: Keyed; Self-Feed Bit Capacity: 1"-4-5/8", Length: 22"



Item #
MI1680-20

MILWAUKEE ELECTRIC TOOL CORP.
1/2" Heavy-Duty Drills

Super-Hawg®

- 2 speed; 1750 rpm, 450 rpm
- 13 amp motor; Low speed clutch protects gear train
- Rotating handle - Roto-Lok® 90° left/right rotation for most comfortable grip position
- Capacity in Steel: 1/2"



Item #
MI1680-21

MILWAUKEE ELECTRIC TOOL CORP.
1/2" D Handle Drills

Heavy-Duty

- 1/2" trigger speed control reversing; 7.0 amp Milwaukee motor
- Capacity in Steel: 1/2"; Current Rating: 7.0 amps, Spindle Diameter and Thread: 1/2" - 20



Item #	No Load RPM	Gear Reduction
MI1107-6	0 - 500	Triple
MI1250-1	0 - 1000	Double

MILWAUKEE ELECTRIC TOOL CORP.
1/2" Right Angle Drills

Heavy-Duty

- 1/2" trigger speed control reversing; 7 amp Milwaukee motors
- Helical cut, heat treated gears
- Capacity in Steel: 1/2"; Volts AC Only: 120



Item #	No Load Drill Only RPM	Gear Train	RPM W/ Rad Low Side	RPM W/ Rad High Side
MI3107-6	0-500	Quadruple	0-335	0-750

MILWAUKEE ELECTRIC TOOL CORP.
1/2" Right Angle Drill Kits

- 1/2" trigger speed control reversing
- Variable speed, control reversing except (single speed reversing)
- Head and handle swivel 360°



Item #	Amps	Low Side RPM with Rad	High Side RPM with Rad
MI3002-1	7.0	0 - 400	0 - 900

MILWAUKEE ELECTRIC TOOL CORP.
3/8" Angle Drills

- Metal framed gear train for longer gear life
- Chuck Size: 3/8; Amps: 3.5
- No Load Speed: 0-1,300 RPM
- Chuck Type: Keyed; Chuck Key W/ Holder



Item #
MI0370-20

MILWAUKEE ELECTRIC TOOL CORP.
Electric Screwdriver

General Purpose

- Powerful 6.5 amp motor, 0 to 2500 rpm, variable speed control; Ramp-off depth locator for easy depth adjustments
- Includes: Tek Locator Assembly, 5/16" Magnetic Hex Socket, Belt Clip



Item #
MI6790-20

MILWAUKEE ELECTRIC TOOL CORP.
6.5 Amp General Purpose Screwdrivers

Heavy-Duty

- Powerful 6.5 amp Milwaukee motor; 2 Ramp-off depth locators for drywall and self-drill fasteners
- Amps: 6.5, No Load RPM: 0-2500, Bit Shank Size: 1/4 hex in.



Item #
MI6791-21



MILWAUKEE ELECTRIC TOOL CORP.
Impact Wrenches

Heavy-Duty



- 7.0 amps
- Square drive, double insulated, reversing
- Forward/reverse rocker switch (AC/DC) is ideal when frequent reversing is necessary
- Variable speed switch offers added control for drilling in wood or driving lag bolts
- Trigger speed control switch includes speed limiting dial for setting desired speed/torque
- Size: 1/2"; Impacts Per Minute: 2600, RPM at No Load: 1800, Torque: 300 ft.-lbs.

Item #
MI9070-20

MILWAUKEE ELECTRIC TOOL CORP.
3/4" Impact Wrench

With Rocker Switch



- 7.0 AMPS
- 1,750 RPM
- 2500 IPM
- 380 ft/lbs torque
- 3/4" Impact Wrench with rocker switch and detent pin socket retention
- AC/DC rocker switch for quick selection of forward and reverse

Item #
MI9075-20

MILWAUKEE ELECTRIC TOOL CORP.
4-1/2" Angle Grinders

7.5 AMP - Paddle Switch



- 7.5 Amp, 825 Max Watts Out Motor
- 25% Longer Lasting Epoxy Protection - extends motor life by protecting the copper wire from abrasion
- Multi-Port Exhaust - reduces motor burn-up by efficiently venting hot air out of the grinder
- X-Large Paddle Switch
- Tool Free, Burst Resistant Guard
- Speed RPM: 10,000
- Includes: Side handle, 4-1/2" wheel, guard, wrench, flanges

Item #
MI6140-30

MILWAUKEE ELECTRIC TOOL CORP.
4-1/2" Angle Grinders

10.0 AMP - Paddle Switch
With Contractor Bag



- 10.0 Amp, 1250 Max Watts Out Motor
- Multi-Port Exhaust - reduces motor burn-up by efficiently venting hot air out of the grinder
- 25% Longer Lasting Epoxy Protection - extends motor life by protecting the copper wire from abrasion
- Soft-Grip 3-Position Handle; Tool Free, Burst Resistant Guard
- Speed RPM: 10,000
- Includes: Slide Handle, 4-1/2" Wheel, Type 27 Guard, Spanner Wrench, Flanges, Contractor Bag

Item #	Desc.
MI6148-30	Paddle w/Lock-on

MILWAUKEE ELECTRIC TOOL CORP.
12 Amp 4-1/2"/5" Small Angle Grinder



- 12.0 Amp, 1490 MWO Motor
- Advanced Electronics - includes ESO: Electronic Shut-Off, CPT: Constant Power technology, OLP: Overload Limit Protection
- ESO: Electronic Shut-Off -shuts down the grinder when the wheel is stalled in a pinch providing greater control and reduced tool damage
- 10,000 RPM
- Soft Grip 3-Position Handle; Tool Free, Burst Resistant Guard
- 4-1/2" & 5" Type 27 Guard Included- for added productivity
- Includes: Side Handle, 4-1/2" & 5" Type 27 Guard, Spanner Wrench, Flanges

Item #	Desc.
MI6116-30	Paddle w/Lock-on

MILWAUKEE ELECTRIC TOOL CORP.
12 Amp 4-1/2"/5" Small Angle Grinder- Paddle (Non Lock-on)



- 12.0 Amp, 1490 MWO Motor
- Advanced Electronics - includes ESO: Electronic Shut-Off, CPT: Constant Power technology, OLP: Overload Limit Protection
- ESO: Electronic Shut-Off - shuts down the grinder when the wheel is stalled in a pinch providing greater control and reduced tool damage
- 10,000 RPM
- Soft Grip 3-Position Handle-provides optimal control during various applications
- Tool Free, Burst Resistant Guard
- 4-1/2" & 5" Type 27 Guard Included
- Includes: 6116-31, Side Handle, 4-1/2" & 5" Type 27 Guard, Spanner Wrench, Flanges

Item #
MI6116-31



MILWAUKEE ELECTRIC TOOL CORP.
7" Angle Grinder

- Powerful 4.0 maximum horse-power, 15 amp motor
- 7" or 9" capacity, 6000 RPM, 120 volts AC-DC
- Two-finger lock-on switch
- Angled handles for more natural hand positions
- Grinder may be converted to sander by using the proper backing pad assembly



Item #

MI6088-20

MILWAUKEE ELECTRIC TOOL CORP.
Guard for Grinding Discs

Type 27

- This guard can be rotated around the gear case shoulder to offer optimum protection to the operator
- No tools required to change/adjust guard



Item #

Size (in.)

MI49-12-0365

4½

MILWAUKEE ELECTRIC TOOL CORP.
4.5 Amp Die Grinder

2", Heavy-Duty

- 2" diameter powerful and smooth running
- For mounted wheels and points up to 1-5/8"
- Reinforced wheels up to 2"
- 4.5 amp, 21,000 rpm



Item #

MI5192

MILWAUKEE ELECTRIC TOOL CORP.
4.5 Amp Die Grinder

2", Double Insulated

- 2" diameter powerful and smooth running
- For mounted wheels and points up to 1-5/8"
- Reinforced wheels up to 2"
- 4.5 amp, 21,000 rpm



Item #

MI5194

MILWAUKEE ELECTRIC TOOL CORP.
3" Diameter Straight Grinder

- 14,500 no-load rpm, 11 amp
- 3 in. diameter wheel
- Coated spindle housing for cool gripping surface
- Hinged face plate for quick easy wheel replacement
- Includes: 3" Diameter Straight Grinder, Wheel Guard, 9/16" Wrench, 1" Wrench



Item #	Length (in.)	Wheel Size (in.)	Hole Dia. (in.)	Spindle Thrd. Size
MI5211	21	½ x 3	¾	¾"-24

MILWAUKEE ELECTRIC TOOL CORP.
Band File

Heavy-Duty

- Double Insulated with on/off paddle switch
- Grind, Deburr, Blend, Clean, Polish, Surface, Condition
- 5.5 Amp Motor
- 1/2" x 18" Contact Arm
- 180° Adjustable Head



Item #

MI6101-6

MILWAUKEE ELECTRIC TOOL CORP.
Dial Speed Control Polishers

- Dial speed control - Exclusive Milwaukee electronic speed control in powerful 11 amp polishers, ideal for clearcoat finishes



Item #	Pad Dia.	Amps	Speed (No Load)
MI5460-6	7/8	11	0 - 1750
MI5540	7	11	0-2800

MILWAUKEE ELECTRIC TOOL CORP.
Heavy-Duty Polishers

- 11.0 Amps
- 0-1750 RPM
- Single speed
- Includes: Side handle, one 7" rubber backing pad, disc nut and nylon washer



Item #

MI5455



MILWAUKEE ELECTRIC TOOL CORP.

Deep Cut Band Saw

- Industry Leading 10.5 Amp Motor
- 0-420 SFPM
- 4-7/8" Cutting Capacity
- Variable Speed Dial & Trigger - adjusts the speed for different materials
- Multi-Grip T-Handle
- Rear Blade Guard
- Adjustable Material Guide - durable steel guide that is adjustable for different materials
- 2-Finger Variable Speed Trigger
- Case included with MI6232-6N



Item #

MI6230N

MI6232-6N

MILWAUKEE ELECTRIC TOOL CORP.

Deep Cut Band Saw -AC/DC

- Industry Leading 10.5 Amp AC/DC Motor
- 420/320 SFPM
- 4-7/8" Cutting Capacity
- Hi/Lo Speed Switch
- Multi-Grip T-Handle
- Rear Blade Guard - 30% thicker steel
- Adjustable Material Guide
- Case included with 6238N



Item #

MI6236N

MI6238N

MILWAUKEE ELECTRIC TOOL CORP.

Compact Band Saw

- 45% Lighter than Deep Cut - 9.5 Lbs compact light weight design for cutting overhead and in tight places
- 200-360 SFPM Variable Speed Dial
- 3-1/4" Cut Capacity – cuts most common materials for Electrician, Plumber and Mechanical cutting applications, single pass cut on 3" copper, 3" angle iron, 2-1/2" conduit
- Tool-Free Adjustable Material Shoe
- LED Work Light
- Blade Ejection System-Quickly change the blade
- Drop Resistant Pulley Guard
- Cast Aluminum Gear Case



Item #

MI6242-6

MILWAUKEE ELECTRIC TOOL CORP.
Portable Drilling Machine Kit

Magnetic

Compact Model No. 4270-21

- Powerful 1.1 max HP - 9.0 Amp
- Milwaukee Motor - enables drilling with up to 1-1/2" diameter annular cutter and 2" depth of cut (D.O.C.)
- Accepts 3/4" diameter shank annular cutters; 1/2" dia. twist bit capacity with a 4-1/4" D.O.C.
- Two position tool-less feed handle can be easily mounted to either side to allow for optimum drilling positions
- High strength magnet; Speed: 450 RPM



Item #

MI4270-21

MILWAUKEE ELECTRIC TOOL CORP.

3/4" Motor for Electromagnetic Drill Press

- 12.5 Amps maximum rating; Solid state electronic switching
- Feedback speed control; Computer controlled reverse
- Line Lock-Out prevents tools from operating should voltage be restored to an interrupted line when switch is locked in the "on" position
- Motor/Magnet interlock; Automatic base/chip de-mag; Soft-start



Item #

MI4262-1

MILWAUKEE ELECTRIC TOOL CORP.

Electromagnetic Base

12.5 Amp, Fixed Position

- Base only fixed position, variable speed base 9" drill travel
- Feedback speed control; Computer controlled reverse
- Line Lock-Out prevents tools from operating should voltage be restored to an interrupted line when switch is locked in the "on" position
- Automatic base/chip de-mag



Item #

MI4202

MILWAUKEE ELECTRIC TOOL CORP.

Electromagnetic Drill Presses

Heavy-Duty

- Base control panel includes variable speed adjusting for motor; Automatic base/chip de-mag, automatic electronic soft start
- Line lock-out - Prevents tool from operating should voltage be restored to an interrupted line when switch is locked in the "on" position
- 3 jaw chuck, 350 RPM
- Includes 4262-1 motor and 4202 base



Item #	Drill (in.)	*Drill Point Pressure (lbs.)
MI4210-1	3/4	1630



MILWAUKEE ELECTRIC TOOL CORP.

18 Gauge Shears

- 6.8 amp Milwaukee motor, trigger speed control: 0-2,500 rpm spindle speed
- 360° swivel head
- Capacity - in Steel: 18 Ga., in Stainless: 20 Ga.
- Trigger Lock, Minimum Cutting Radius: 7"



Item #

MI6852-20

MILWAUKEE ELECTRIC TOOL CORP.

Electric Nibbler

16 Gauge

- Cutter can be set in 8 positions to make cutting easier
- Can cut 16 gauge steel and 18 gauge stainless
- Amps: 4.0, Capacity: in Steel - 16 Ga.; in Stainless - 18 Ga.



Item #

MI6890

MILWAUKEE ELECTRIC TOOL CORP.

14" Dry-Cut Saw

15 Amps

- Powerful 4.8 max HP motor, 15 amp motor (1,500 rpm)
- Tool-free fence and vise system
- Bevel Capacity: 45°, Capacity in O.D. Pipe: 5-3/8", Capacity in Square Stock: 5", Maximum Opening: 8"



Item #

MI6190-20

MILWAUKEE ELECTRIC TOOL CORP.

Cut-Off Machine Saws

14" Abrasive

- Powerful 15 amp motor designed for maximum cutting efficiency
- 5" pipe cutting capacity
- Quick Release Locking Vise:



Item #

MI6176-20

MILWAUKEE ELECTRIC TOOL CORP.

8" Circular Saw

For Metal Cutting

- Dry-cut technology provides faster, cleaner, more affordable metal cutting
- Durable blade shield with integral chiptank deflects/collects hot chips and sparks
- 2-9/16" cut depth
- Powerful 13.0 amp, 3,700 rpm motor
- Premium cermet-tipped blades cut faster, cleaner, and longer



Item #

MI6370-21

MILWAUKEE ELECTRIC TOOL CORP.

Heat Gun

- Unique impact resistant heating element
- Rotate rear housing to select temperature ranges 140 degrees F-1040 degrees F
- 11.6 amps, 14.8 air volume cu. ft. min.



Item #

MI8977-20

MILWAUKEE ELECTRIC TOOL CORP.

Heavy-Duty Heat Gun

- Dual temperature 570°F and 1000°F
- 3 position rocker switch - off, high and low
- Impact resistant heating element
- Current Rating: 11.6 A, Air Volume: 14.8 cu. ft. min.



Item #

MI8975-6

MILWAUKEE ELECTRIC TOOL CORP.

11.6 Amp Heavy-Duty Heat Gun Kit

- Impact resistant heating element
- Dual temperature 570° F and 1000° F
- Amps: 11.6, Air Volume Cu. Ft. Min.: 14.8, Air Temperatures deg. F: 570 and 1000



Item #

MI8980

MILWAUKEE ELECTRIC TOOL CORP.

Right Angle Attachment

- Compact design allows work in tight areas
- Durable all metal housing and steel gears
- Accepts standard 1/4" hex shank bits



Item #

MI49-22-8510



MILWAUKEE ELECTRIC TOOL CORP.
33° Angle Drive Kit

- Stretches drilling reach up to 30"
- Allows drilling up to 2-9/16" diameter holes
- Use 33° angle drive with 30" extension only



Item #
MI48-06-2860

MILWAUKEE ELECTRIC TOOL CORP.
30" Right Angle Drive Extension

- Comes complete with 30" extension tube, drive shaft with hex socket on both ends, two clamping collars and a side handle
- 30" extension



Item #
MI48-95-0400



MAKITA USA
18V Impact Hammer DriverDrill Kit

LXT Lithium-Ion Hybrid™

- Capacity: Hex Shank 1/4"
- Impact: No Load RPM 0-2,300; Impacts/Min.(IPM) 0-3,200; Torque (in.-lbs.) 1,280
- Hammer Drill Blows/Min.(BPM): Low 0-2,300; High 0-27,600
- Drill No Load RPM: Low 0-700; High 0-2,300
- Driver: Clutch Settings 16
- Hybrid™ 4-function tool
- Includes: 2 LXT Lithium-Ion 3.0 Ah Batteries (194205-3), 45-minute Optimum Charger (DC18SC), Tool Case (8247535)



Item #
MABTP140

MAKITA USA
18V Impact Driver

LXT Lithium-Ion

- LXT Lithium-Ion
- Capacity: Hex Shank 1/4"
- No Load RPM: 0-2,300; Impacts/Min.(IPM): 0-3,200
- Torque (in.-lbs.): 1,330
- Ergonomic shape fits like a glove with even pressure and easy control
- Built-in LED light
- 30-minute rapid optimum charge
- Includes: 2 Lithium-Ion 3.0 Ah batteries (BL1830), 1 Rapid Optimum Battery Charger (DC18RA), Tool Case (824753-5), Rugged Tool Belt Hook (324705-1), Plastic Battery Cover (450128-8)



Item #
MABTD141

MAKITA USA
18V 1/2" Driver-Drill Kit

LXT Lithium-ion

- Chuck (metal): 1/2"
- Capacity: Steel: 1/2"; Wood: 2-9/16"
- No Load RPM: Low: 0-300; Mid: 0-600; High: 0-1,700
- LXT Lithium-Ion
- Two built-in LED lights
- 3-Speed design produces 25% faster working speed with more efficiency in a wider range of applications
- Shift-Lock™ drive system quickly shifts from "hammer drill" to "driver" mode



Includes:

- 2 LXT Lithium-Ion 3.0 Ah Batteries (194205-3)
- 45-Minute Optimum Charger (DC18SC)
- Screwdriver Bits (784637-8)
- Carrying Case (824754-3)

Item #
MABDF451

MAKITA USA
18V 1/2" Hammer Driver-Drill Kit

LXT Lithium-Ion

- Capacity: In Steel - 1/2"; In Wood - 2-9/16"; In Masonry - 5/8"
- 2-Speed all metal transmission (0-400 / 0-1,700 RPM)
- Shift-Lock™ drive system quickly shifts between modes
- 2 Trigger-forward built-in LED lights
- Includes: 2 ea. 18V LXT Lithium-Ion 3.0 Ah Battery (BL1830), 1 Rapid Optimum Battery Charger (DC18RA), Tool Case (824753-5), Tool Belt Clip (324705-1), Side Handle (450651-3), Depth Gauge (322223-3), Bit Holder (419276-2), Screwdriver Bits (784637-8), Plastic Battery Cover (450128-8)



Item #
MABHP454



MAKITA USA
18V Compact 1/2" Driver-Drill Kit



- Capacity: Steel 1/2"; Wood 1-1/2"
- No Load RPM: Low 0-450; High 0-1,500
- Max Torque (in.-lbs.): 450; PT1 Torque (in.-lbs.): 285
- More compact design at only 8" long
- Makita Lithium-Ion provides longer run time, 5x lower self-discharge (for use any time) & 16 firm holding contact terminals (for constant high power)
- Built-in LED light illuminates the work area
- Accepts all Lithium-Ion slide-style batteries
- Includes: 2 Compact Lithium-Ion Batteries (194309-1), 15-Minute Rapid Charger (DC18RA), Tool Case (824774-7)

Item #
MABDF452HW

MAKITA USA
18V 1/2" Impact Wrench Kit

Lithium-Ion



- Capacity: Square Drive 1/2"
- No Load RPM: 1,600
- Impacts/Min.(IPM): 2,200
- Makita-built motor delivers 325 ft. lbs. of torque
- Large rocker switch for easier tool usage
- Single LED light
- Includes: Tool Hook and Screw (345736-7 & 251314-2), Contractor Bag (821007-X), 2 Lithium-Ion 3.0Ah Batteries (BL1830), 1 Rapid Optimum Battery Charger (DC18RA), Plastic Battery Cover (450128-8)

Item #
MABTW450

MAKITA USA
18V Impact Driver Kit

LXT Lithium-Ion



- Capacity: Hex Shank 1/4"
- No Load RPM: 0-2,300; Impacts/Min.(IPM): 0-3,200
- Torque (in.-lbs.): 1,280
- 15-minute rapid optimum charger and battery
- 15-minute rapid optimum charger has a built-in fan to cool the battery to produce more lifetime work
- Built-in LED light
- Compact Lithium-Ion Batteries (194309-1), 15-Minute Rapid Charger (DC18RA), Tool Case (824774-7)

Item #
MABTD142HW

MAKITA USA
18V 5-3/8" Metal Cut Saw

Lithium-Ion



- Blade Diameter: 5-3/8"
- Arbor: 5-8"
- No Load RPM: 3,400
- Max. Cutting Depth: 2"
- Cuts Unistrut® all thread, channel, corrugated, conduit, pipe, sheet metal, square tubing, steel and more
- Built-in LED lights
- Includes: 2 LXT Lithium-Ion 3.0 Ah Batteries (194205-3), Rapid Charger (DC18RA), Carbide-Tipped 30T Blade (A-94518), Tool Case

Item #
MABCS550

MAKITA USA
18V Portable Band Saw Kit

LXT Lithium-Ion



- Maximum cutting capacities: Round Workpiece: 4-3/4"p; Rectangular Workpiece: 4-3/4" X 4-3/4"p
 - Makita-built motor, 6-setting variable speed dial at 275 - 530 ft./min.
 - Adjustable foot protects material & provides positive support for accurate cuts
 - Two built-in LED lights
 - Built-in protective rubber bumpers
 - Built-in skyhook
- Specifications:
- No load speed: 275-530 Ft./Min.p
 - Watt hours: 54.0p
 - Battery: 18VDC (3.0Ah)p
 - Overall length: 20-5/8"
 - Includes: 2 LXT Lithium-Ion 3.0Ah Batteries (194205-3), 45-Minute Optimum Charger (DC18SC), Blade (792559-8), Tool Case (824766-6)

Item #
MABPB180

MAKITA USA
18V Recipro Saw

LXT Lithium-Ion



- Max. Cutting Depth : Pipe 5-1/8"; Wood (w/12" blade) 10"
- Length of stroke: 1-1/8"
- Strokes/Min.(SPM): 0-2,900
- Two built-in LED lights
- One-handed, fast tool-less blade changes and shoe adjustments
- Retractable hook allows tool to remain close-by, but never in the way
- Includes: 2 LXT Lithium-Ion 3.0Ah Batteries (194205-3), 45-Minute Optimum Charger (DC18SC), Blade, Carrying Case (8247608)

Item #
MABJR181



MAKITA USA
18 Volt 3/8" Angle Drill

LXT Lithium-Ion

- Variable speed (0-1,800 RPM)
- 3/8" keyed metal chuck
- Built-in LED light
- Easy to handle large paddle switch with soft grip
- Includes: 2 ea. 18V LXT Lithium-Ion 3.0 Ah Battery (BL1830), 1 Rapid Optimum Battery Charger (DC18RA), Contractor Bag (821007-X), Plastic Battery Cover (450128-8), Chuck Key Holder (450688-0), Chuck Key (763415-9)



Item #
MABDA350

MAKITA USA
18 Volt Jig Saw Kit

LXT Lithium-Ion

- Accepts "T" (Tang) shank blades
- Length of stroke: 1"
- Max. Cutting Capacity: Wood 5-5/16"; Steel 3/8"
- Cut Settings: 3 Orbital +, Straight Cutting
- Strokes/Min.: 0 - 2,600 SPM
- Bevel Capacity: 45°
- Low vibration and noise level for more control and comfort
- 4-Pole Position cut settings (3 Orbital and 1 Straight)
- Built-in LED lights
- "Tool-less" push-in lock system for extremely fast blade installation and removal
- Includes: 2 Lithium-Ion batteries, charger, blade set, bag



Item #
MABJV180

MAKITA USA
18V Grinder-Tool Only

LXT Lithium-Ion

- * BARE TOOL ONLY
- Makita built produces 50% faster grinding with an impressive 10,000 RPM
 - Built-in electronic control circuit with LED warning lights for overload protection
 - Slide switch with lock-on



Item #
MABGA452Z

MAKITA USA
18V Rechargeable Flashlights

LXT Lithium-Ion

- 4-position head pivots for greater versatility
- High illumination emits high power at 4,500 Lux; New Xenon bulb for extra brightness
- Uses LXT Lithium-Ion battery



Item #
MABML185

MAKITA USA
18V 2-Piece Combo Kit

LXT Lithium-Ion

- 18V LXT Hammer Drill BHP454
- 18V LXT Impact Driver BTD141
- 2-Speed 1/2" hammer drive-drill (0-400/0-1,700 RPM) with Makita - built 4-pole motor delivers 560 in. lbs. of torque; Variable speed impact driver (0-2,300 RPM) provides 1,330 in. lbs. of torque
- 30-minute rapid optimum charger
- Includes: 2 ea. LXT Lithium-Ion 3.0Ah batteries (BL1830), 1 rapid optimum battery, charger (DC18RA), tool case (8248125-5)



Item #
MALXT218

MAKITA USA
18V Compact 2-Piece Combo Kit

Lithium-Ion

- 1/2" Drill BDF452
- Impact BTD142
- 1/2" driver-drill delivers 450 in. lbs. of torque; Impact driver provides 1,280 in. lbs. of maximum torque
- Includes: 2 Lithium-Ion 1.5Ah batteries (BL1815), 5-minute rapid charger (DC18RA), contractor bag (831274-0)



Item #
MALCT200W

MAKITA USA
18V Compact 2-Piece Combo Kit

Lithium-Ion

- 18V LXT Impact Driver BTD141
- 18V 1/2" LXT Hammer Driver-Drill BHP452
- 2-Speed 1/2" hammer driver-drill (0-400 / 0-1,500 RPM) with Makita-built 4-pole motor delivers 450 in. lbs. of torque
- Variable speed impact driver (0-2,300 RPM) provides 1,330 in. lbs. of torque
- Includes: 2 ea. LXT Lithium-Ion 3.0 Ah Batteries (BL1830), 1 30 Min. Rapid Optimum Battery Charger (DC18RA), Tool Case (824812-5)



Item #
MALXT211



MAKITA USA

18V 4-Piece Combo Kit

Lithium

- 1/2" Drill BHP452
- Impact BTD141
- Sawsall BJR1822
- 1/2" hammer driver-drill has a new 4-pole motor for 450 in. lbs. of torque
- Impact driver is 40% more compact, 1,280 in. lbs. of torque with 0-3,200 IPM
- Reciprocating saw with tool-less blade changes & shoe adjustments, skyhook
- 4-position flashlight with Xenon bulbs
- Includes: 2 LXT Lithium-Ion 3.0Ah batteries (BL1830), 30-minute rapid charger (DC18RA), contractor bag



Item #

MALXT407

MAKITA USA

18V 6-Piece Combo Kit

LXT Lithium-Ion

- 1/2" Hammer Drill BHP452
- Impact BTD141
- 6-1/2" Circular Saw BSS611
- Sawsall BJR182
- 4-1/2" Grinder BGA452
- 1/2" hammer driver-drill has a new 4-pole motor for 560 in. lbs. of torque
- 6-1/2" circular saw has a D35 high torque motor, built-in blower
- Recipro saw with tool-less blade changes and shoe adjustments, skyhook
- Impact driver is 40% more compact, 1,280 in. lbs. of torque with 0-3,200 IPM
- 4-1/2" cordless cut-off/angle grinder
- 4-position flashlight with Xenon bulbs
- Includes: 2 LXT Lithium-Ion 3.0Ah batteries (194205-3), 45-minute optimum charger (DC18SC), contractor bag with wheels



Item #

MALXT601

MAKITA USA

18V 7-Piece Combo Kit

- 18V LXT 1/2" Hammer Driver-Drill BHP452
- 18V LXT 6-1/2" Circular Saw BSS611
- 18V LXT Recipro Saw BJR182
- 18V LXT Impact Driver BTD141
- 8V LXT 4-1/2" Cut-Off/Angle Grinder BGA452
- 8V LXT Flashlight BML185
- FM/AM Job Site Radio BMR100W
- 1/2" hammer driver-drill has a 4-pole motor for 450 in/lbs of torque
- 6-1/2" circular saw has a D35 high torque motor
- Reciprocating saw with tool-less blade changes & shoe adjustments
- Impact driver is 40% more compact, 1,330 in. lbs. of torque with 0-3,200 IPM
- 4-1/2" cordless cut-off/angle grinder, 10,000 RPM
- 30-minute rapid optimum charger; 4-position flashlight with Xenon bulbs
- Rugged FM/AM job site radio with 10 pre-set buttons and MP3 compatible (auxiliary jack)
- Includes: 2 ea. LXT Lithium-Ion 3.0 Ah batteries (BL1830), 1 rapid optimum battery charger (DC18RA), contractor bag with wheels and telescoping handle (831269-3)



Item #

MALXT702

MAKITA USA

18V Concrete Vibrator

LXT Lithium-Ion

- Vibrator Diameter: 1"; Vibrator Length: 8-11/16"
- Shaft Length: 4' ; Overall Length: 58-1/2"
- No Load Vibrations Per Minute: 13,000
- Makita built motor produces 12,500 VPM to help increase strength of concrete
- More compact design at only 58-1/2" long and weighs only 8.2 lbs.
- Ergonomic dual directional switch to conveniently hold the tool either horizontal or vertical positions
- 45-minute optimum charger; Built-in LED light
- 1" diameter head supported by dual ball bearing
- Includes: 2 LXT Lithium-Ion 3.0 Ah batteries (194205-3), 45-minute optimum charger (DC18SC), tool case (824768-2)



Item #

MABVR450

MAKITA USA

18V LXT Lithium-Ion Battery

- LXT Lithium-Ion Batteries
- Built-in Memory Chip: Memorizes the usage history & communicates with the charger
- Anytime Charge: Lithium-Ion batteries have no memory effect and can be charged at any time
- 1.5 Amp Hour



Item #

MABL1815



MAKITA USA
18V LXT Lithium-Ion Battery
BL1830



- Charging at any time will have no effect on the battery; built-in shock absorbing features protect the battery
- Battery's built-in memory chip communicates with the charger to maximize battery life using 3 active controls (Current, Voltage & Thermal)

Item #
MABL1830

MAKITA USA
9.6V Cordless Reciprocating Saw



- 9/16" Stroke; Speed: 2700 SPM
- Uses special blade for maximum efficiency
- Cuts wood, mild steel and more; compact and lightweight for easy handling
- MODEL 4390DW includes: battery, charger, 1 ea. blade (792540-9, 792541-7), hex wrench
- Cutting Capacities: Soft wood-15/16"; Hard wood-1/2"; Pipe: 1-5/8"x5/64"

Item #
MA4390DW

MAKITA USA
7.2V Cordless Impact Driver Kit

Lithium-Ion



- 2,300 RPM and 3,000 IPM
- Convenient 1/4" hex chuck for quick bit changes ; built-in LED light; operates in straight or pistol grip positions
- Includes: 2 7.2V batteries, charger, bit set, holster, bag

Item #
MATD020DSEW

MAKITA USA
Reciprocating Saws



- Anti-Vibration Technology (AVT) gives unmatched comfort
- Clutch: The clutch protects the gears should the blade bind adding life to the tool; orbital action
- Variable Speed Preset Dial: 6 different preset speeds to match the speed of the saw to the application
- Electronic Speed Control: The blade can be inserted with one hand and ejected without touching the hot blade

Item #	Amps
MAJR3070CT	15

MAKITA USA
10" Dual Slide Compound Miter Saw



- Built-in laser with micro fine adjustments clearly indicates line of cut; independent switch allows laser to be seen independently of blade rotation
- Dual steel rails supported by linear ball bearings ensure stable, accurate cutting
- Powerful, direct drive 15 AMP motor
- Bevel positive stops at 33.9° and 45° left with 45° right
- Long slide track and wide pivot angle allow cross cuts up to 4x12 material
- Blade Diameter: 10"; Arbor: 5/8"; No Load RPM: 3,700

Item #
MALS1016L

MAKITA USA
12" Dual Slide Compound Miter Saw



With Laser

- 15.0 Amps
- Large cutting capacity for up to 8" crown molding (nested), 6-1/2" baseboard (vertical), and 15" crosscut at 90°
- Compact design with a patented 4-Steel Rail Sliding System further increases rigidity to produce superior cuts
- Exclusive 5-1/2" tall dual sliding fence system features versatile upper and lower fence adjustments for more precise miter and bevel cuts
- Miters 0°-52° left and 0°-60° right, with positive stops at 0°, 15°, 22.5°, 31.6° and 45° (left and right)
- Bevels 0°-45° (left and right) with positive stops at 0°, 22.5°, 33.9° and 45° (left and right)

Item #
MALS1216L

MAKITA USA
15 Amp Table Saw



- Right extension table allows for greater cutting capacity with the capability to rip 4X8 sheets of plywood
- Large cutting capacity (3-5/8" at 90° and 2-1/2" at 45°)
- Powerful 15 AMP motor delivers 4,800 RPM and has electric brake
- Extended capacity with up to 25" ripping
- Saw blade enclosed underneath the table to protect the blade during transport
- Dead-on cam-locking rip fence and bevel locking handle for fast and easy adjustments

Specifications:

- Blade Diameter: 10"; Arbor: 5/8"
- Max. Cutting Capacity: 90° - 3-5/8", 45° - 2-1/2"
- No Load RPM: 4,800
- AMPS: 15.0

Item #
MA2705X1



MAKITA USA
7-1/4" Circular Saw

- Powerful 15 AMP motor for a high power-to-weight ratio
- Bevel cuts 0-45° with a 45° cutting capacity of 1-3/4"
- Conveniently located shaft lock for easy blade replacement

Specifications:

- Blade diameter: 7-1/4" p
- Arbor: 5/8"
- No load speed: 5,800 RPM

Item #
MA5007NK



MAKITA USA
16-5/16" Circular Saw
w/ Electric Brake

- Large capacity blade cuts 6-1/4" at 90° and 4-3/16" at 45°
- Electric brake for maximum productivity
- Blade stabilizer for stable blade rotation and superior cutting performance
- Large depth control lever for convenience and secure adjustments

Specifications:

- Blade Diameter: 16-5/16"
- Arbor: 1"
- Max. Cutting Capacity: at 90° - 6-1/4", at 45° - 4-3/16"
- No Load RPM: 2,200
- Watts out: 1,800
- AMPS: 15

Item #
MA5402NA



MAKITA USA
7-1/4" Hypoid Saws

- Efficient hypoid gears deliver more power with greater surface contact than worm drive gears
- Retractable hook allows tool to remain close-by
- Blade-left design improves visibility and provides a clear view of the cut line for accuracy
- Powerful 15 AMP motor
- 0° - 50° bevel cutting capacity is ideal for truss and rafter cut-outs
- Blade Diameter: 7-1/4"
- Arbor: 5/8"
- Max. Cutting Capacity - at 90° 2-3/8"; at 45° 1-3/4"; at 50° 1-9/16"
- No Load RPM: 4,300

Item #
MA5477NB



MAKITA USA
7-1/4" Magnesium Hypoid Saw

- Magnesium components create a lightweight saw (13.0 lbs.) that is well-balanced and jobsite tough
- Retractable hook allows tool to remain close-by

Specifications:

- Blade Diameter: 7-1/4"
- Arbor: 5/8"
- Max. Cutting Capacity: at 90° - 2-3/8", at 45° - 1-3/4"
- No Load Speed: 4,500 RPM
- AMPS (120V): 15.0

Item #
MA5377MG



MAKITA USA
1/2" Electric Drill

Variable Speed, Reversible

- Powerful 7 AMP motor for heavy duty industrial performance
- Large trigger switch is conveniently located
- Capacity: Steel 1/2"; Wood 1-1/2"
- No Load RPM: 0 - 900

Item #
MADP4000



MAKITA USA
1/2" Angle Drill

2-Speed, Reversible Sidewinder

- 2-Speed selector switch for high speed drilling (1,200 RPM) or low speed (300 RPM) for large diameter
- Torque limiter disengages motor should the bit bind (low speed only)
- Powerful 10 AMP motor for improved performance
- Adjustable top handle with hex wrench storage for easy positioning

Item #
MADA4031



MAKITA USA
2.8 Amp Right Angle Drill

3/8", Keyed Chuck

- 4.0 Amps
- VSR 0-1400 RPM
- Variable speed with reverse for easy starting and fastening screws; paddle switch for easy one hand operation
- Compact design for tight fits and close quarter drilling
- Capacities: Steel - 3/8"; Wood - 5/8"

Item #
MADA3010F





MAKITA USA

3/4" Impact Wrench

Reversible



- Powerful 9 AMP motor for heavy-duty applications
- Rocker type reversing switch for easy one-handed forward or reverse operation
- Includes: Side Handle, Steel Tool Case
- Capacity - Square Drive: 3/4"; Bolt Drive: 5/8" - 7/8"
- Impacts/min. (IPM): 1,600; No Load RPM: 1,700
- Torque (ft.-lbs.): 433

Item #

MA6906

MAKITA USA

1" Rotary Hammer

SDS-Plus, Variable Speed, Reversible



- Impact Energy 2.4 Joules
- Powerful 7.0 AMP motor delivers 0-1,100 RPM & 0-4,500 BPM for the most demanding applications
- Torque limiting clutch engineered to prevent gear damage by automatically disengaging gears if the bit binds

Item #

MAHR2475

MAKITA USA

1-9/16" Rotary Hammer

SDS Max, Variable Speed



- Powerful 11 AMP motor; efficient 1,350 - 2,750 BPM
- One touch sliding chuck accepts SDS-Max hammer steel
- 2-mode switch for "hammering only" or "hammering with rotation"
- Preset variable speed dial with 5 settings
- LED power light indicates switch failure or cord breakage; LED service light indicates carbon brushes need to be replaced
- Includes: Side Handle, D-Handle, Depth Gauge, Bit Grease, Tool Case
- Capacity-Concrete (with core bits): 4-1/8"
- No Load RPM: 235 - 480

Item #

MAHR4001C

MAKITA USA

11 Lb. Demolition Hammer



- Unique anti-vibration spring is positioned between tool body and rear handle for reduced operator fatigue
- Accepts same shank demolition bits as spline shank rotary hammers; One-touch tool retainer action for easy accessory installation and removal
- 2,900 BPM; AMPS: 8.3

Item #

MAHM0810B

MAKITA USA

70 Lb. Breaker Hammer



- Powerful 15 AMP motor; efficient 1,100 BPM to tackle the most demanding jobs
- Accepts popular 1-1/8" hex hammer steel
- Cylindrical tool holder enables new bolt holes to be drilled should the original bolts break
- Warning lamp indicates trouble with the cord; AC/DC switch for use with alternative power sources

Item #

MAHM1810X

MAKITA USA

14" Power Cutter

73cc



- Engine: Displacement (cu. in.) 4.5; Max. Power (HP) 5.6; No Load RPM 9,350
- Five-stage, foam-paper-nylon system with advanced directional air flow provides very clean air for better saw performance
- Improved ignition system with larger flywheel and rare earth magnets
- Cutting arm position simply changes from center position to flush (outboard) position allowing cuts directly adjacent to curb edges, walls or directly above the ground
- Cushioned operator grips with 4 vibration-absorption rubber buffers for increased operator comfort
- Water kit is assembled to saw and can be used with garden hose, gravity tank or pressure tank
- Includes: 14" Cut-off Wheel (965-210-222), Universal Wrench (941-719-140), Torx Wrench (940-827-000), Screwdriver (944-340-001), Adaptor Ring (22 mm to 1") (394-228-120)

Item #

MADPC7331

MAKITA USA

4-1/2" Angle Grinder

with Paddle Switch



- Powerful 7.5 AMP motor
- Small diameter barrel grip (only 2-1/2")
- Lock-on/off feature for continuous operation; AC/DC switch for use with alternative power source
- Extra large paddle switch for comfortable operation

Item #

MA9557PB



MAKITA USA
4-1/2" Angle Grinder

with Aluminum Case, Diamond Blade & Grinding Wheels



- Small diameter barrel grip (only 2-1/2")
- Extra large paddle switch for easy operation; lock-on/off feature for continuous operation
- 7.5 AMP motor
- AC/DC switch for use with alternative power sources
- Includes: Grinder, diamond blade, grinding wheel, case

Item #
MA9557PBX1

MAKITA USA
4-1/2" Angle Grinder

- Small circumference barrel grip (only 2.5")
- Rotatable gear housing rotates 90° for cutting applications
- No Load Speed: 11,000 RPM
- AMPS (120V): 6.0
- Spindle Thread: 5/8-11



Item #
MAGA4530

MAKITA USA
5" Angle Grinder

9.0 Amp - Heavy-Duty

- 10,000 RPM; Powerful 9 Amp motor
- Removable side handle can be installed on either side
- Shaft lock for easy accessory changes
- Standard 5/8"-11 UNC spindle
- Double insulated



Item #
MA9005B

MAKITA USA
6" Cut-Off/Angle Grinder

Industrial

- Improved 12 AMP motor; 5-stage variable speed control dial (4,000-9,000 RPM)
- Electronic limiter stops the motor and prevents accidental motor overload and burnout
- Cut-Off Wheel: 6"; Sanding Disc: 6"; Wire Cup Brush: 3"
- No Load RPM: 4,000-9,000
- Spindle Thread (11 UNC): 5/8"



Item #
MA9566CV

MAKITA USA
15 Amp 9" Motor Angle Grinder



- 15 AMP motor
- Great for welders, fabricators, masons, maintenance/repair etc.
- Grinding Wheel: 9"
- Wire Cup Brush: 6"
- Sanding Disc: 7"
- No Load RPM: 6,000
- Spindle Thread (11 UNC): 5/8"

Item #
MAGA9020

MAKITA USA
1/4" Die Grinder



- 3.5 AMPS
- High speed motor (25,000 RPM)
- AC/DC switch for use with alternative power source
- Stepped neck of solid aluminum housing for added durability
- Collet: 1/4"
- No Load RPM: 25,000

Item #
MAGD0601

MAKITA USA
1/4" Die Grinder



- High power 6.6 AMP motor
- Electronic speed control maintains constant speed under load
- Speed control dial for setting the optimal speed for various materials
- Double insulated
- Collet: 1/8" - 1/4"
- No Load RPM: 7,000 - 28,000

Item #
MAGD0800C

MAKITA USA
10 Amp 7" Electronic Sanders & Polisher



- 7" Electronic Sander-Polisher (variable speed)
- Pre-set speed setting dial (600 - 3,000 RPM) for maximum control
- Electronic speed control maintains constant speed under load

Item #
MA9227C



MAKITA USA

Portable Band Saws

- Large 4-3/4" x 4-3/4" capacity for round or rectangular stock
- Built-in fluorescent job light
- 5 preset speeds allows the user to match the speed of the saw to the material needed to be cut
- Variable speed of 200 – 350 ft/min. for more accurate cuts
- Heavy-duty 6.5 AMP motor for all jobsite applications



Item #

MA2107FK

MAKITA USA

5 Amp Belt Sander

Variable Speed

- Variable belt speed (656 - 3,280 ft./min.)
- Narrow belt and exposed front pulley for use on irregular shapes
- Multi-position side handle for easy and comfortable operation
- Connects to dust collector for a cleaner work environment



Item #

MA9031

MAKITA USA

15 Amp 14" Abrasive Chop Saw

- 15.0 AMPS
- D-shape handle for easy gripping
- Lock-off button
- Guide plate adjusts 45° right and left - 3 locations for various sizes of materials
- Quick release vise for secure stock retention and fast repeat cuts
- Max. cutting capacities: 90°- 4-1/2", 45°- 4-1/2"



Item #

MA2414NB

MAKITA USA

3" x 21" Belt Sander

7.8 Amp, 1180 Ft/Min

- 8.8 AMPS
- Speed 1180 SFPM
- Powerful hi-tech motor for maximum production
- Efficient dust collector for reduced sawdust
- Extended base allows flush sanding



Item #

MA9903

MAKITA USA

11 Amp Belt Sander

4" x 24" With Dust Bag

- 11 Amps
- 4" wide belt with a speed of 1,640 ft./min
- Unique design allows flush sanding to walls
- Large front grip is positioned for operator comfort
- Dust bag swivels 360° for more convenient operation



Item #

MA9403

MAKITA USA

Wheel Sander

- Powerful 7.8 AMP motor delivers 3,500 RPM for fast and efficient paint and rust removal; brings out wood grain
- Unique design allows smooth and even surface removal
- Adjustable front roller for uniform pressure to work piece
- Well balanced with a low center of gravity for easy operation
- Electric brake for fast stopping of the wheel
- Wheel size (width x diameter): 4-3/4" x 4"
- No Load RPM: 3,500



Item #

MA9741

MAKITA USA

Belt Sander

Variable Speed

- 8.8 AMPS
- Auto-tracking belt system tracks belt without adjustment
- Dust bag for a cleaner work environment
- Belt Size: 3" x 21"; Belt Speed (ft/min): 690 - 1,440



Item #

MA9903

MAKITA USA

4 Amp Professional Planer Kit

5,000 RPM

- High power-to-weight ratio (4 AMP; 5.5 lbs.)
- Simple blade setting system for fast blade installation
- Precision machine aluminum base for planing accuracy
- Double edged carbide blades for long life and smooth cutting
- Planing Width: 3-1/4"; Planing Depth: 1/32"; No Load Speed: 15,000 RPM, AMPS (115V): 4.0,



Item #

MAKP0800K



MAKITA USA
Fiber Cement Shear Kit

Variable Speed

- 6.5 AMPS
- Cuts fiber cement quickly while producing less dust
- Solid steel blades cut clean, straight lines with a maximum cutting capacity up to 5/16"
- Retractable tool hook allows user to work in tight spaces
- Strokes/min.(SPM): 0 - 2,500



Item #

MAJS8000

MAKITA USA

5" Concrete Planer

- Powerful 10.0 AMP motor
- For smooth finishes on concrete surfaces or leveling of seams
- Electronic Speed Control engineered to maintain constant speed under load
- Electronic Current Limiter helps protect the motor from overloading
- Easy to install/remove dust bag for cleaner operation
- LED power light serves as a pilot light as well as indicates anti-restart function



Item #

MAPC5000C

MAKITA USA

Cordless Tool Battery

*Pod Style Rechargeable
Nickel-Cadmium*

- 2.4 AMP Hours



Item #	NiCad Series	Volt	Wt
MA192827-3	1822	18	2.5

MAKITA USA
Batteries

- Cell type: NiMH

Item #	Volts
MA193890-9	9.6
MA193159-1	18



MAKITA USA
**Cordless Tool
Battery Charger**

- Charging Technology: Controls current, voltage & temperature to maximize battery life
- Forced Air Cooling Fan: Cools the battery by forcing cool air through the battery's built-in air vents
- Cell Type: Lithium Ion
- Amp Hour: 1.3 - 3.3



Item #

MADC18RA

MAKITA USA

Battery Charger

- Cell Type: Ni-MH/Ni-Cd
- Amp Hour: 1.3 - 3.0
- Volts: 1.2 - 18



Item #

MADC1804

MAKITA USA

Automotive Battery Charger

Ni-HH & Ni-CD

- Automotive
- Amp hour: 1.3 - 3.0
- Voltage: 7.2V - 18V



Item #

MADC1822

MAKITA USA

**18V Cordless FM/AM
Job Site Radio**

LXT Lithium-Ion

- Delivers rich stereo sound from two powerful 3-1/4" side-firing speakers
- 10 Pre-Set AM/FM buttons and mp3 compatible
- Digital backlit quartz display
- Compatible with Makita 9.6V - 24V Slide-Style and Pod-Style Batteries



Item #

MABMR100W

MAKITA USA

12V Battery

1234

- Cell Type: Ni-MH
- Amp Hour: 2.6
- Style: Pod



Item #

MA193157-5



MAKITA USA
14.4V Battery
1434

- Cell Type: Ni-MH
- Amp Hour: 2.6
- Style: Pod



Item #
MA193158-3

MAKITA USA
9.6V Ni-CD Battery
B9000

- 9.6V Cordless 1.3 Ah Stick Battery
- Features 1.3 amp-hour capacity and durable plastic housing



Item #
MAB9000

MAKITA USA
7.2V Lithium Battery
BL7010

- 1/2 lb. lighter than 7.2v Ni-Cd batteries
- 1.0 amp hour



Item #
MABL7010

MAKITA USA
Steel Saw Blade

- Premium quality steel blades for longer life; Chisel grind
- Hardened steel body prevents blade warping
- Designed for faster smoother cutting; precision teeth can be easily resharpened
- Combination general purpose - General purpose blade for fast and smooth rip, crosscuts, and miters
- Max RPM: 2,760; Kerf: .093"; Plate: .062"



Item #	Desc.	Arbor (in.)	Hook (deg.)	Model
MA792116-2	16 ⁵ / ₁₆ " x 50T	25 mm	20	5402NA

MAKITA USA
Carbide-Tipped Saw Blades

Cut Cleaner

- Blade Dia.: 12"; No. of Teeth: 60
- Application: Ferrous Metal
- Model: LC1230



Item #
MAA-90532

MAKITA USA
Carbide-Tipped Saw Blades

Thin Kerf Design

- Thin kerf design for a lighter cutting load and eliminates wasted material; individually hand-hammered by skilled saw technicians for guaranteed flatness and proper tension
- 60 Precision ground teeth permit a clean cutting surface and a long blade life
- Grind: ATB



Item #	Blade Dia. (in.)	Arbor	Max. Safe Speed	Model
MA792118-8	16 ⁵ / ₁₆	25 mm	3,500	5402NA

MAKITA USA
Carbide-Tipped Saw Blades

Beam & Timber

- Description: 16-5/16" x 32T
- Arbor: 25 mm; Hook: 20°; Kerf: .109"
- Max. RPM: 3,500



Item #
MAA-90956



BLACK & DECKER
14" Abrasive Wheel

DeWalt

Double reinforced with industrial grit and glue for increased life and faster cuts.

- Diameter: 14"; Thickness: 3/32"; Arbor : 1"
- Max. RPM: 4,100



Item #	Type & Material
DTDW8001	AO General Purpose Metal
DTDW8002	AO Bar Cutter

BLACK & DECKER
Chop Saw Wheels

DeWalt

Double reinforced with two full sheets of fiber-glass for safety and performance.

Premium grain for added wheel life and speed.

Enhanced formulations provide longer life and optimal performance.

High quality resin bonds that are 100% inspected before use for product consistency and quality.

- 7/64" edge thickness; 1" arbor
- Grit A24R



Item #	Desc.	Dia.	Edge Thck.	Type 1	Max. RPM
DTDW8004	General purpose cutter	12	3/32	A24	5,095
DTDW8003	Stud cutter	14	3/32	A24	4,100



BOSCH TOOLS
Cordless Battery
10.8V Lithion™

- For use with all Bosch 10.8V Lithion tools

Item #
BAT411



BOSCH TOOLS
Cordless Battery

2.4 Amp Hour
Bluecore™

- Fully compatible with all Bosch cordless tools
- Innovative Bluecore™ cooling rods placed between battery cells to absorb heat and protect battery from damage

Item #	Volt Series
BOBAT021	24 V
BOBAT240	24 V
BAT181	18 V



BOSCH TOOLS
1 Hour Battery Charger
Bluecore™

- Checks battery status every second to prevent overheating and over-charging
- Charger Volt Range: 7.2V - 24V

Item #
BOBC004



BOSCH TOOLS
Jobsite Radio

AM/FM Stereo w/CD & Remote
Power Box™

- Watts: 3.5 watt radio amplifier
- Radio/CD run off Bosch batteries or AC power - 12V, 14.4V, 18V, 24V
- Integrated jobsite CD player with CD-R/RW and MP3 compatibility
- 4-way GFCI protected outlet Power-up jobsite tools and equipment. Meets OSHA requirements
- FM Stereo AM tuner with 20 FM and 10 AM station presets
- Charger: 12V - 24V Bosch Batteries

Item #
PB10-CD



BOSCH TOOLS
Demolition
Reciprocating Saw

- 15 AMP
- Anti-vibration System
- Lockjaw™ Blade System – Fast, extremely easy, push to insert blade and twist to eject blade
- Orbital Action
- No Load SPM: 0 - 2,900
- Stroke Length: 1-1/4"

Item #
BORS35



BOSCH TOOLS
6.5 Amp 5-1/2" Trim Saw

Left-Hand Blade
Skil

- Left-hand blade design with 5-1/2" blade
- Specifications:
- Amperage 6.5
 - Arbor Size 1/2" Round
 - Blade Diameter 5-1/2"
 - No load RPM 4,000

Item #
SLHD5510



BOSCH TOOLS
7-1/4" Circular Saw

- High-strength magnesium footplate for unmatched durability and flatness
- 56° Bevel
- Amperage: 15
- No Load RPM: 5,600
- Blade Diameter: 7-1/4"
- Arbor Size: 5/8"

Item #
CS10



BOSCH TOOLS
15 Amp 7-1/4" Worm Drive Saw

- 15.0 AMPS
- 7-1/4" Worm drive saw with rear handle
- Magnesium motor housing - Durable and light weight
- Magnesium footplate - "Waffle-design" for greater strength and stability

Item #
BO1677M





BOSCH TOOLS
13 Amp 8-1/4"

Worm Drive Circular Saw

Skil



- Exclusive 60° bevel feature with 8-1/4" blade
- Precision-machined worm drive gears

Specifications:

- Amperage 13.0; Arbor Size Diamond
- Blade Diameter 8-1/4"; No Load RPM 4,300

Item #
SLHD5860

BOSCH TOOLS

13 Amp 7-1/4"

Worm Drive Circular Saw

Skil



- Precision-machined worm drive gears with 7-1/4" blade

Specifications:

- Amperage: 13.0; Arbor Size Diamond
- Blade Diameter: 7-1/4"; No Load RPM 4,400

Item #
SLHD77

BOSCH TOOLS

**13 Amp 7-1/4" Magnesium
Worm Drive Circular Saw**

Skil



- Light magnesium housing (2 lbs. lighter) with 7-1/4" blade
- Precision-machined worm drive gears

Specifications:

- Amperage 13.0; Arbor Size Diamond
- Blade Diameter: 7-1/4"; No Load RPM 4,400

Item #
SLHD77M

BOSCH TOOLS

Top Handle Jig Saw

With Case



- Powerful 6.5-Amp Jigsaw
- Variable speed - Dial sets maximum speed and accelerator trigger controls operating speed
- Exclusive multi-directional blade clamp provides superior grip of T-shank blades. (JS365 does not accept U-shank blades.)
- Sturdy die-cast foot; Four orbital-action settings; Adjustable dust blower

Item #
BOJS365

BOSCH TOOLS

**4.6 Amp Variable
Speed Tapper**



- Variable speed with adjusting knob to match correct speed to job application
- "Push" into work for forward rotation (clockwise)
- "Pull" away from work for reverse rotation (counterclockwise)
- Self-aligning chuck coupling allows tap to straighten if started crooked

Item #
BO1462VS

BOSCH TOOLS

**7/8" 6.9 Amp
Rotary Hammer**



D-handle

- 6.9 AMPS
- Impact Energy: 1.6 ft-lbs.
- 7/8" Rotary Hammer
- D-Handle design for extra control
- Capacity: 3/16"-7/8"
- BPM: 0-6150

Item #
BO11224VSR

BOSCH TOOLS

1" Rotary Hammer



*SDS-plus® Xtreme
Bulldog™*

- 7.2 Amps
- Impact Energy: 2.2 ft/lbs.
- 0-1,300 RPM; 0-5,800 BPM
- Multi-function Selector — 3 modes of operation, rotation only, rotary hammer and hammer-only mode
- SDS-plus® bit system
- Capacity: 3/16"-1"

Item #
BO11255VSR

BOSCH TOOLS

1-9/16" Combination Hammer

SDS-Max®



- Amperage: 10
- Impact Energy: 5.2 ft/lbs
- SDS-Max® bit system tool-free bit changes with automatic bit locking
- "Combination" dual mode selector 2 modes of operation, rotary hammer and hammer only
- Max. Hole Diameter in Concrete: 1-9/16
- Max. Hole Diameter in Concrete-Core Bit: 4

Item #
BO11240



BOSCH TOOLS
1-9/16"
Combination Hammer



Spline

- Amperage: 10
- Impact Energy: 5.2 ft/lbs
- Spline/round hex bit system — tool-free bit changes, with automatic bit locking "Combination" dual mode selector — 2 modes of operation, rotary hammer and hammer only mode Vario-Lock™ positioning
- Max. Hole Diameter in Concrete: 1-9/16"
- Max. Hole Diameter in Concrete-Core Bit: 4" Max.

Item #

BO11247

BOSCH TOOLS
1-3/4" Rotary Hammer
SDS-Max®



- Amperage: 13.5
- Impact Energy: 9.6 ft/lbs
- "Combination" dual mode selector 2 modes of operation, rotary hammer and hammer only mode
- Variable speed dial for accurate bit starting and controlled chipping applications
- Max. Hole Diameter in Concrete: 1-3/4"
- Max. Hole Diameter in Concrete-Core Bit: 6"

Item #

BO11263EVS

BOSCH TOOLS
Breaker Hammer
Brute™



- Amperage: 15.0
- Impact Energy: 43 ft/lbs
- The plug-in anywhere hammer does not need a compressor
- 8" Diameter semi-pneumatic, ball bearing wheels, easy rolling over rough job sites
- Rugged 1" diameter all welded steel frame, plus heavy-duty rubber tie-down
- 2-way tool retainer accepts standard 1-1/8 hex, air tool steel with retaining collar of Bosch internal combo steel

Item #

BO11304K

BOSCH TOOLS
14" Cutoff Machine Kit

Abrasive



- AC/DC capability — Extends the versatility of the tool by working from DC outlets such as welders and generators
- Amperage: 15.0
- Depth of Cut: 4-7/8"
- No Load RPM: 4,300
- Spindle Thread: 5/8"-11
- Includes: 14" cutting wheel, wrench, case

Item #

BO1365K

BOSCH TOOLS
5" Rat Tail Grinder



- Amperage: 9.5
- AC/DC Capability extends the versatility of the tool by working from DC outlets such as welders and generators
- No Load RPM: 11,000
- Spindle Thread: 5/8"-11
- Wheel Diameter: 5"

Item #

BO1821

BOSCH TOOLS
16 Gauge Shears

4.2 Amp



- 4.2 AMPS
- Cutting Capacity: 16 gauge
- Upper/lower blades can be rotated 4x90° for new sharp edge extends blade life
- Steel deflector for hand protection
- Visible blade allows precise pattern cutting
- Easy blade adjustment when switching material thickness

Item #

BO1500C

BOSCH TOOLS
14 Gauge Nibbler



- 4.6 Amps, 2400 SPM
- Burr-free edges
- Full swivel die available — For cutting in all directions
- Corrugated, trapezoidal or full square stock — All cut efficiently with a simple cutter change
- Cutting Capacity: Mild Steel - 14 ga.

Item #

BO1530



BOSCH TOOLS
16 Gauge Nibbler

- 5 Amps, 1,700 SPM
- Ejects chips downward — away from workpiece and operator
- 3-Position head cuts forward, left & right



Item #
BO1534

BOSCH TOOLS
18 Gauge Nibbler

- Amperage: 3.2
- Unique cutting head design — For multiple types of corrugated steel
- Ejects chips downward away from operator and workpiece
- 3-Position head cuts forward, left & right



Item #
BO1529B

BOSCH TOOLS
Variable-Speed Palm Router Kit
Colt™

- 1.0 HP (Max. Tool Output) — 5.6 Amp Motor -35,000 RPM
- Rugged Aluminum Fixed Base — Durable, solid and precise; Fast & Precise Depth Adjustment System
- Enhanced Bit Capacity — Fixed Base accepts bits up to 1-5/16" in diameter
- Offset Base with Spindle Lock — Allows routing near vertical surfaces
- Tilt Base with Detents at Key Angles — Allows routing at special angles and in hard-to-reach areas
- Straight Edge Guide — Guides router along edges of workpiece or up to 3-5/8" from edge



Item #
PR20EVSNK

BOSCH TOOLS
14.3 Amp Industrial Heat Gun

750° Max Temperature

- 14.3 AMPS
- Powerful blower gives the high air volume needed for industrial applications
- Air intake regulator allows variable temperature adjustment
- Insulated nozzle provides cool exterior temperature; integral stand allows benchtop use
- Temp Settings: 750°-1100° F



Item #
BO1942

BOSCH TOOLS
Heat Gun Kit

Programmable

- 4 Easily storable temperature and airflow combinations provide one-button access to the exact settings needed for key applications
- Liquid Crystal Display - For precise setting of temperature and airflow
- 109 temperature settings - Precision temperature control with setting every 10° from 120° - 1200° F
- 10 blower air volume settings - Precision airflow control from 3.6 to 17.6 CFM (cubic feet per minute)
- Amperage: 13
- Temp. Settings: 120° - 1,200°F



Item #
BO1944LCDK

BOSCH TOOLS
Right Angle Drive Attachment
SDS-Plus®

- For SDS Rotary Hammer Models: 11224VSR, 11224VSR, 11225VSR/VSRH, 11250VSR
- Remove hammer side handle to attach
- Tool length increases by 2-3/4, but length is offset by less than the shank insertion depth into the bit holder
- Sales Pack Quantity: 1



Item #
BO1 618 580 000

BOSCH TOOLS
Chuck With Integral Shank
SDS-Plus®

- For wood, metal and fastening
- Can be used in the hammer-only mode
- For all Bosch SDS-plus® Rotary Hammers



Item #
BO1 618 571 014



FEIN POWER TOOLS, INC.
MultiMaster Select Set

- 1 Fein Multimaster FMM 250 Q, variable speed and with QuickIN quick-action system
- 1 sanding pad
- 5 grit each 60, 80, 120, 180 grit sandpaper
- 1 universal E-CUT saw blade
- 1 rigid scraper blade
- 1 key and mounting bolts
- 1 Carbide-tipped segment saw blade
- 1 HSS segment saw blade



Item #
FNFMM250QSELECT

FEIN POWER TOOLS, INC.
MultiMaster Top Set

- 1 Fein Multimaster FMM 250 Q, variable speed and with speed and with quick action system in a sturdy plastic case
- 1 Sanding pad
- 5 Grit each 60, 80, 120, 180 grit sandpaper
- 1 Universal E-CUT saw blade
- 1 Rigid scraper blade
- 1 Key and mounting bolts
- 1 Carbide-tipped segment saw blade
- 1 HSS segment saw blade
- 1 Sanding pad, perforated
- 5 of ea. type of sanding sheet, grit 60, 80, 120 and 180, perforated
- 1 Dust extraction device
- 1 Carbide rasp, perforated
- 1 Profile sanding set



Item #
ESFNFMM250QTOP

FEIN POWER TOOLS, INC.
MultiMaster Start Set

- 1 Fein Multimaster FMM 250, variable speed
- 1 sanding pad
- 5 grit each 60, 80, 120, 180 grit sandpaper
- 1 universal E-CUT saw blade
- 1 rigid scraper blade
- 1 key and mounting bolts



Item #
FNFMM250START

FEIN POWER TOOLS, INC.
**MultiMaster E-Cut
Saw Blades**



Universal Narrow

- Saws wood up to 2", plastics, sheet metal up to 14 gauge copper or aluminum pipes and profiles, flush cut capable

Item #	Size (in.)	Qty./Pkg.
FN6-35-02-151-01-8	1 1/8"	1

FEIN POWER TOOLS, INC.
**MultiMaster E-Cut
Saw Blades**



Precision Narrow

- Highest cutting speed and precision with double-row Japanese toothting
- For wood up to 2", drywall and soft plastics, flush cut capable

Item #	Size (in.)	Qty./Pkg.
FN6-35-02-126-01-3	1 3/8"	1

FEIN POWER TOOLS, INC.
**MultiMaster Segment
Cutting Blades**



Convex

- For cutting rigid materials such as plastic, linoleum, rubber, cardboard, leather, woven wire cloth, looped fabric/carpet floor coverings, and much more

Item #	Qty./Pkg.
FN6-39-03-205-01-5	1

FEIN POWER TOOLS, INC.
**MultiMaster HSS
Segment Saw Blade**



- For plastics, fiberglass, wood, putty, non-ferrous metals and sheet steel up to approx. 19 gauge
- Ideal for working in corners

Item #	Size (in.)	Qty./Pkg.
FN6-35-02-106-01-5	3 3/8"	1

FEIN POWER TOOLS, INC.
**MultiMaster Diamond
Saw Blade**



- For cutting through, epoxy grout, marble and concrete truss joints
- Low dust generation, very high service life

Item #	Size (in.)
FN6-35-02-105-01-2	2 1/2"



FEIN POWER TOOLS, INC.

MultiMaster HSS Saw Blade

- Circular, recessed, flush cut capable
- For plastics, fiberglass, wood, putty, non-ferrous metals and sheet steel up to approx. 19 gauge, level with the surface

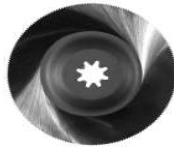

Item #	Size (in.)	Qty./Pkg.
FN6-35-02-144-01-4	3 ⁹ / ₁₆	1

FEIN POWER TOOLS, INC.

MultiMaster Segment Scraper Blades

Rigid

- For removing stubborn old paint, adhesive residues, carpeting, tile adhesive and undercoatings, caulking, and flush cut capable



Item #	Qty./Pkg.
FN6-39-03-178-01-7	1

FEIN POWER TOOLS, INC.

MultiMaster Segment Scraper Blades

Flexible

- For removing silicone or acrylic caulking



Item #	Qty./Pkg.
FN6-39-03-165-01-3	2

FEIN POWER TOOLS, INC.

MultiMaster Carbide Rasp

- For coarse sanding, filler, tile adhesive, concrete, stone and wood
- Suitable for use without or without dust extraction



Item #	Desc.	Qty./Pkg.
FN6-37-31-001-01-4	Triangular	1
FN6-37-31-002-01-7	Finger Shape	1

FEIN POWER TOOLS, INC.

MultiMaster Carbide Tipped Saw Blade

- For cutting out defective tile joints and for milling cracks in plaster, porous concrete and similar building materials
- Recessed, flush cut capable



Item #	Desc.	Size (in.)
FN6-35-02-118-01-6	Standard Blade Segment	2 ¹ / ₂

FEIN POWER TOOLS, INC.

MultiMaster Sanding Sheets

- For universal application on practically all surfaces

Item #	Grit	Qty./Pkg.
FN6-37-17-082-04-9	60	5
FN6-37-17-083-04-3	80	5
FN6-37-17-085-04-5	120	5
FN6-37-17-088-04-0	180	5
FN6-37-17-090-04-6	240	5



FEIN POWER TOOLS, INC.

MultiMaster Sanding Sheets

Dust Extraction

- For sanding with dust extraction
- Universal application on practically all surfaces
- Corundum sanding grains, fully bonded with artificial resins guarantee high sanding capacity

Item #	Grit	Qty./Pkg.
FN6-37-17-108-04-7	40	5
FN6-37-17-109-04-1	60	5
FN6-37-17-110-04-3	80	5
FN6-37-17-111-04-2	100	5
FN6-37-17-112-04-5	120	5
FN6-37-17-115-04-1	220	5
FN6-37-17-116-04-4	240	5

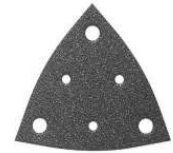

FEIN POWER TOOLS, INC.

MultiMaster Sanding Sheet Set

- 4 sanding sheets of each grit 60 / 80 / 120 / 180

Item #	Desc.
FN6-37-17-227-01-0	16 Sheets



FEIN POWER TOOLS, INC.

MultiMaster 4-1/2" Sanding Sheets

16 Packs

- Sanding sheets guarantee high quality results: dia. 4-1/2"
- Perforated for dust extraction, resin bonded for high material removal performance, hook and loop attachment

Item #	Grit
FN6-37-17-230-02-0	40
FN6-37-17-227-02-0	60
FN6-37-17-228-02-0	80
FN6-37-17-229-01-0	120
FN6-37-17-231-02-0	180
FN6-37-17-232-01-0	240





FEIN POWER TOOLS, INC.
MultiMaster Sanding Sheet Sets

Velcro



- For universal application on practically all surfaces
- Corundum sanding Grits and bonded artificial resins guarantee high sanding capacity
- 10 sheets per set, with H & L 60, 80, 120, 180, 240 grit

Item #
FN6-37-17-082-03-3

FEIN POWER TOOLS, INC.
MultiMaster Sanding Disc Sets

- 1 sanding disc, dia. 4-1/2"
- 6 sanding sheets (2 of ea. grit 60/80/180)



Item #
FN6-38-06-195-02-0

FEIN POWER TOOLS, INC.
MultiMaster Sanding Pads



Item #	Desc.	Qty./Pkg.
FN6-38-06-129-02-6	Velcro	2
FN6-38-06-136-02-9	Dust Extraction	2

FEIN POWER TOOLS, INC.
MultiMaster Profi Wood Kit

- 1 each - E-Cut saw blade 126, E-CUT saw blade 127, E-Cut saw blade 151, sanding pad
- 5 each - sanding sheets Grit 60, sanding sheets Grit 120



Item #
FN6-39-03-167-40-2

FEIN POWER TOOLS, INC.
MultiMaster Minicut & File Set

Sawing

- For cut-outs 3/8" and above
- 2 saw blades for wood and soft plastics; 2 HSS saw blades for hard plastics, fiberglass and sheet steel up to 19 gauge
- 1 each - diamond file, carbide file



Item #
FN6-39-01-025-06-0

FEIN POWER TOOLS, INC.
MultiMaster Profi Floor Kit

- 1 each - E-Cut saw blade 127, E-CUT saw blade 133, E-Cut saw blade 134, carbide rasp, rigid scraper, segment blade convex

Item #
FN6-39-03-167-41-1



FEIN POWER TOOLS, INC.
MultiMaster Profile Sanding Set

- Includes 1 holder and 6 different professional attachments
- 1 V-form for 90° angle
- 1 x trapezoidal for tongue and groove joints
- 1 for straight edges
- 1 x convex form (large), 1 x concave and 1 convex form (small)
- 5 sheets each 80, 120, 180 grit sandpaper

Item #
FN6-38-06-183-01-3



ROTOZIP
Cordless Spiral Saw®

18V Power, 30,000 RPM

- Compatible with Bosch® 18V Litheon™ Lithium-Ion batteries and chargers



Includes:

- CR18L Cordless Spiral Saw™ with collet system
- One 18-volt Bosch Litheon™ Lithium-Ion battery; 50-minute battery charger
- One drywall and one Multipurpose XBITS™
- Two collets: 1/8" and 5/32"

Item #
RZCR18L-1100

ROTOZIP
Spiral Saw System
Rotozip®

- 5.5 Amp Power; 30,000 RPM
- 50 ft. Cord - Industry 1st increases user mobility and eliminates the need for extension cords
- Soft Band Handle enhances the feel of the tool's body and provides hand comfort when using the tool for long periods of time
- Quick release foot
- Can be adjusted for cuts up to 1" deep
- 5/32" Collet System



Item #
RZRZ25



ROTOZIP
Drywall Router

6.0 Amp Magna Core™ Motor,
33,000 RPM

- DR1 drywall router with collet system
- Two drywall XBITS™
- Three collets: 1/8", 5/32", and 1/4"



Item #
RZDR01-1100

ROTOZIP
Standard Point Zip® Bits

- For basic drywall cut-outs

Item #	Desc.	Diameter (in.)
RZZB8	8 Pack	1/8"



ROTOZIP
Guidepoint™ Zip® Bits

- For drywall cut-outs around outlet boxes and framing

Item #	Desc.	Diameter (in.)
RZGP8	8 Pack	1/8"



ROTOZIP
Sabrecut™ Zip® Bits

- For a variety of materials from wood to fiberglass

Item #	Desc.	Diameter (in.)
RZSC4	4 Pack	1/8"



ROTOZIP
Window & Door Zip® Bits

- For cutting window and door openings in drywall

Item #	Desc.	Diameter (in.)
RZWD1	1 Pack	1/4"



ROTOZIP
Drywall XBITS™

- For faster, controlled drywall cut-outs from outlets to window/door openings

Item #	Desc.
RZXB-DW10	10 Pack



ROTOZIP
Fiberock® Zip® Bits

- For Fiberock® panels

Item #	Desc.	Diameter (in.)
RZFBR1	1 Pack	1/4"



ROTOZIP
Tilecut™ Zip® Bits

- For ceramic wall tile (only soft tile with glazing), cement board, stucco, and plaster

Item #	Desc.	Diameter (in.)
RZTC1	1 Pack	1/8"



ROTOZIP
ZipMate® Attachment

w/ Zip® Wheel
Rotozip®

- Cuts up to 9/16" depth with ease
- Allows you to use wheels for cutting an even wider variety of materials: ceramic floor tile, stone, slate steel, iron, aluminum brick, cement, concrete, sandstone, and more
- Allows you to make intricate cuts in very hard materials without the hassle of a wet-saw



Item #
RZM3-1100

ROTOZIP
Grout Removal Attachment Kit

For use on wall, floor, and corner grout. Quick, easy, and efficient way to remove grout for replacing broken tiles or cleaning up grout. Includes:

- 1/4" Grout Removal Zip® Bit



Item #
RZRZ-GRK

ROTOZIP
Replacement Collets and Nuts

Item #	Desc.
RZCT125	1/8" Collet & Nut
RZCT156	5/32" Collet & Nut
RZCT250	1/4" Collet & Nut





BOSCH TOOLS
Dremel Electric Engraver

- 7,200 SPM
- Engraves metal, plastic, glass and wood
- Carbide tip



Item #

BO290-01

BOSCH TOOLS
Dremel Electric Engraver Kit

- 7,200 SPM
- Engraves metal, plastic, glass and wood
- Includes: Engraver, letter/number template, carbide engraving point



Item #

BO290-KIT



KETT TOOL COMPANY
Panel/Cable Saw

- Slits thin-walled metal-clad cable to aid in stripping, and can be used on either aluminum or steel armored cable
- The KS-226 has a 2500 RPM, 5 amp electric motor and a cast aluminum saw head



Item #

KEKS-226

KETT TOOL COMPANY
18/20 Gauge Power Shear

Double-Cut

- 5.0 Amps
- Feed quickly and quietly, without warping or bending your finished piece
- Easily follows a scribed line
- Swiping action of blades seals the edge of coated metals
- Capacity Mild Steel/Stainless (ga.): 18/20
- Max RPM: 2500



Item #

KEK-200

KETT TOOL COMPANY
18 Gauge Pneumatic Shear

Double-Cut

- Double-cutting action of the P-500, cleanly cuts 18 gauge and lighter C.R. mild steel without distortion
- Variable speed trigger lets you control speed from 0 to 2200 RPM's
- Ideal for the tinner, roofer and auto body shop



Item #

KEP-500

KETT TOOL COMPANY
14/16 Gauge Power Shear Kit

Pistol-Grip

- 5.0 Amps
- KD-440 with 251-4 carrying case
- Cuts 14 gauge mild steel and most grades of stainless to 16 gauge; double-insulated, cuts at over 150 inches per minute
- Capacity Mild Steel/Stainless (ga.): 14/16
- Max RPM: 2500



Item #

KEKIT#340

KETT TOOL COMPANY
18/20 Gauge Power Shear Kit

Double-Cut

- 5.0 Amps
- Double-cut shears feed quickly and quietly, without warping or bending your finished piece; easily follows a scribed line
- Capacity Mild Steel/Stainless (ga.): 18/20
- Max RPM: 2500
- Nibbler Attachment - cuts intricate curves in 18 gauge C.R. mild steel at 40 inches per minute, cuts straight, left or right with unique swivel punch and die assembly, can be locked in any 360 degree position & cuts a clean, even line at 3/16" wide



Item #

Desc.

KEKIT#100 KD-200 w/251-4 carrying case

KEKIT#210 KD-200 shear, 1020 nibbler attachment and 251-4 carrying case

KETT TOOL COMPANY
Variable Speed

Power Shear Kit

- 5.0 Amps
- KD-442 with 251-4 carrying case
- Variable speed shear easily cuts through 16 gauge C.R. mild steel and stainless to 18 gauge
- The steel shear head has close cutting heavy duty blades that quickly cut through sheet metal, spiral pipe, metal doors and metal studs



Item #

KEKIT#342



KETT TOOL COMPANY
Fiber Cement Power Shear

- Designed to make quick work of cement board up to 1/2"
- No airborne dust for minimal clean up
- Variable cutting speeds up to 2500 RPM



Item #
KEKD-493

KETT TOOL COMPANY
Variable Speed Power Shear

- 5.0 Amps
- Cuts through 16 gauge C.R. mild steel & stainless to 18 ga.
- The steel shear head has close cutting heavy duty blades that quickly cut through sheet metal, spiral pipe, metal doors and metal studs



Item #
KEKD-442

KETT TOOL COMPANY
Shear Head

14 Gauge

- 14 gauge steel shear head - used on KD-440, P-540, P-1040 and discontinued E-140 and KC-140 shears



Item #
KE40-20

KETT TOOL COMPANY
Shear Head

16 Gauge

- 16 gauge aluminum shear head - used on KD-242, KD-442, P-542, P-1042 and discontinued K-242 and K-442 shears



Item #
KE42-20

KETT TOOL COMPANY
Shear Head

18 Gauge

- 18 gauge shear head - used on KD-200, P-500, P-1060 and discontinued B-100, K-100 and K-200 shears



Item #
KE60-20

KETT TOOL COMPANY
Shear Head

5/8" Capacity

- 5/8" capacity steel shear head
- For cutting fiber-cement



Item #
KE95-20

KETT TOOL COMPANY
Scissors Shear Head

- 24 gauge steel scissors shear head
- Used on KD-441, P-541, P-1041 and discontinued E-141 and KC-141 shears



Item #	Desc.
PKE41-20	Shear Head
PKE41-21	Center Scissors Blade
PKE41-22	Side Knife

KETT TOOL COMPANY
18 Gauge C.R. Mild Steel

Nibbler Attachment

- Cuts intricate curves in 18 gauge C.R. mild steel at 40 inches per minute, cuts straight, left or right with unique swivel punch and die assembly, can be locked in any 360 degree position and cuts a clean, even line at 3/16" wide



Item #
KE1020

KETT TOOL COMPANY
Kett Saws Blades

Item #	Desc.
KE157-24	1½X44T
KE157-26	1½X60T
KE157-54	2"X44T
KE157-56	2"X60T
KE157-58	2"X80T



KETT TOOL COMPANY
Power Shear Replacement Blades

Item #	Desc.
KE40-21	1¼ GA Shears, Center
KE60-21	18 GA Shears, Center
KE60-22L	Side Knife Left
KE60-22R	Side Knife Right
KEKIT#102	18 GA Blade Kit (KD-200)
KEKIT#106	1¼ GA Blade Kit





KETT TOOL COMPANY
Blade Kit

Heavy User

- Heavy User Blade Kit
Includes: 1 ea. 60-22R, 60-22L, 60-24, 60-25; 2 ea. 60-21, 60-27; 3 ea. 60-28



Item #
KEKIT#101

KETT TOOL COMPANY
Fiber Cement Power Shear

Replacement Blades

- Replacement blades for 1/2" fiber-cement shear



Item #	Desc.
PKE92-21	Center Blade
PKE92-22	Side Knife
PKEKIT#109	(1) 92-21 and (2) 92-22.



METABO CORPORATION
6" Angle Grinder

Electric - 1400 Watt

- 12.2 Amps
- High-powered angle grinder with extra high cooling capacity for fast work progress even under the toughest operating conditions
- Includes Metabo dust-protection technology for an extremely long device service life
- Metabo S-automatic torque limiting clutch
- Metabo "Quick" tool quick change



Item #	Rated Load Speed	Spindle Thrd. Size
MTW14-150QUICK	9000 /min	5/8" - 11 UNC

METABO CORPORATION
4-1/2" Angle Grinder

Electric - 800 Watt

- 8.0 Amps
- High-powered angle grinder with extra high cooling capacity for fast work progress even under the toughest operating conditions
- Includes Metabo dust-protection technology for an extremely long device service life
- Metabo S-automatic torque limiting clutch



Item #	Rated Load Speed	Spindle Thrd. Size
MTW8-115	10000/min	5/8" - 11

METABO CORPORATION
6" Angle Grinder

Electric - 1400 Watt

- 12.2 Amps
- Robust Metabo Marathon motor
- Spindle lock
- Rotating main handle without tools
- Additional VibraTech handle for vibration damping
- Adjustment of protective cover without tools
- Safety switch: lock against unintentional start
- Especially high torque



Item #	Rated Load Speed	Spindle Thrd. Size
MTW14-150ERGO	7300/min	5/8" - 11 UNC

METABO CORPORATION
Type 1 "Slicer-Plus" High Performance Grinding Wheels

Spec: A 60 TX---Coated Aluminum oxide formulated to provide very long life and very aggressive cool cutting action on all metals.



Item #	Size (dia. x thick. x arbor)	Application	Max. RPM
MT655996000	4 x .045 x 5/8"	Steel/Stainless Steel	15,000
MT655997000	4 1/2 x .045 x 7/8"	Steel/Stainless Steel	15,000
MT655993000	5 x .045 x 7/8"	Steel/Stainless Steel	12,225
MT655998000	6 x .045 x 7/8"	Steel/Stainless Steel	10,185



M K MORSE
14" Metal Cutting Chop Saw
Metal Devil®

- 120V/60Hz/15Amp
- No Load Speed: 1300 RPM
- Blade Diameter: 14"
- Arbor Hole: 1"



Cutting Capabilities:

- Round: 45° - 4-1/8"; 90° - 5-1/8"
- Square: 45° - 3-1/2" x 3-1/2"; 90° - 4-3/4" x 4-3/4"
- Rectangle: 45° - 3-1/8" x 4-3/8"; 90° - 3-3/4" x 7-1/4"

Features:

- 0° - 45° mitering vise
- Plexiglass safety shield
- Chip collection chamber
- Retractable blade guard

Item #
MKCSM14B



M K MORSE
**9" Metal Cutting
Circular Saw**
Metal Devil®



- 1800 Watts/120V/60Hz/15Amp
- No-load Speed: 2500 RPM
- Blade Diameter: 9"
- Arbor Hole: 1"

Cutting Capabilities:

- Maximum Cutting Reach: 3-1/4"; Maximum Thickness of Cut (Mild Steel): 3/8"; Bevel Cut: 0-45°

Features:

- Laser Guide; 0°-45° beveling; 30 min. duty cycle; Overload switch; Chip collection chamber; Retractable blade guard; Durable Carrying case

Item #	Part #
MKCSM9MB	CSM9MB

M K MORSE
**7" Metal Cutting
Circular Saw**
Metal Devil®



- 1080 Watts/120V/60Hz/9Amp
- No-Load Speed: 3500 RPM
- Blade Diameter: 7"
- Arbor Hole: 20mm

Cutting Capabilities:

- Maximum Cutting Reach: 2.36"; Maximum Thickness Cut (Mild Steel): 1/4"

Features:

- External overload switch; Chip Collection Chamber; Retractable blade guard; Durable Carrying case

Item #
MKCSM7MB

M K MORSE
Circular Saw Blades

*Metal Cutting
Metal Devil®*



- Hardened steel plate for durability
- Cut Cool; Cutting tips do not transfer heat to inner plate so you can pick up parts immediately after cutting
- Cutting tips are a unique combination of tungsten carbide and titanium carbide
- 5/8 KO fits both diamond and circular arbors

Item #	Blade Dia. (in.)	Number of Teeth	Arbor (in.)	Applications	Max RPM
MKCSM53850AC	5 3/8	50	5/8	Aluminum	4200
MKCSM1260NSC	12	60	1	Steel	2000
MKCSM1280AC	12	80	1	Aluminum	3800
MKCSM1280TSC	12	80	1	Thin Steel	2000
MKCSM1466NSC	14	66	1	Steel	1800
MKCSM1480AC	14	80	1	Aluminum	3800
MKCSM1490SSC	14	90	1	Stainless Steel	1800
MKCSM1490TSC	14	90	1	Thin Steel	1800
MKCSM53830SC	5 3/8	30	3/8 and 1/2	Steel	4200
MKCSM53850TSC	5 3/8	50	3/8 and 1/2	Thin Steel	4200
MKCSM65040SC	6 1/2	40	5/8	Steel	4200
MKCSM65048TSC	6 1/2	48	5/8	Thin Steel	4200
MKCSM72540SC	7 1/4	40	5/8 KO	Steel	5800
MKCSM72548NSC	7 1/4	48	5/8 KO	Steel	5800
MKCSM72560AC	7 1/4	60	5/8 KO	Aluminum	5800
MKCSM72568TSC	7 1/4	68	5/8 KO	Thin Steel	5800
MKCSM1080AC	10	80	5/8 KO	Aluminum	5500



WMH TOOL GROUP
9" Horizontal Bandsaw
JET



- Large handwheel and built-in gauge for easy blade tensioning
- Coolant is distributed through the blade guides
- Blade guides feature parallel double row ball bearing support; blade brush is built-in and self-propelled
- Quick-positioning vise with fully adjustable jaws swivels to 45°
- Removable chip tray for quick clean-up
- Blade is fully guarded regardless of blade guide position
- Fully adjustable hydraulic downfeed with separate on/off valve
- Automatic shut-off after cut
- Carbide blade guides with rollers
- Coolant system
- 4/6VT Bi-metal blade
- Adjustable material stop

Specifications:

- Round Capacity @ 90°: 9 in.
- Round Capacity @ 45°: 9 in.
- Rectangle Capacity @ 90°: 2 in. x 16 in. - 9 in. x 14 in.
- Rectangle Capacity @ 45°: 9 in. x 6-1/8 in.
- Blade Speeds (SFPM): 82, 132, 170, 235

Item #
JEHBS-916W

WMH TOOL GROUP
7" X 12" Horizontal/Vertical Bandsaw
JET



- UL listed motor
- Heavy cast iron bow and bed
- Hydraulic downfeed for ease of cut; hardened and ground worm gear
- Roller cabinet with built-in chip tray
- Automatic shut-off after cut

Standard Equipment:

- Vertical worktable
- Coolant system
- 3/4" Bi-metal blade
- Adjustable material stop
- Chip brush

Specifications:

- Round Capacity @ 90°: 7 in.
- Round Capacity @ 45°: 4-1/2 in.
- Rectangle Capacity @ 90°: 2 in. x 12 in. - 7 in. x 8-1/2 in.
- Rectangle Capacity @ 45°: 7 in. x 5 in.
- Blade Speeds (SFPM): 80, 130, 180, 285

Item #
JEHVBS-7MW

WMH TOOL GROUP
20" Floor Drill Press
JET



- Hinged metal belt and pulley cover coupled with quick adjustment motor mount allow rapid changing of spindle speeds
- Rotating, 45° tilting, crank-operated worktable with quick release clamp
- On/off switch located on front of the drill press head
- A 1/2" diameter external positive depth stop with three nut locking feature for quick adjustment
- Adjustable tension spindle return spring
- Spindle is supported by high quality ball bearings
- Built-in work lamp on all models, bulb not included
- Drill chuck and key included

Specifications:

- Drilling Capacity: 1 in.
- Chuck Size: 3/4 in.
- Spindle Travel: 4-5/8 in.
- Spindle Distance to Base: 46-3/4 in.; Spindle Distance to Table (max/min): 18-5/8 in. / 16-1/8 in.
- Number of Spindle Speeds: 12; Range of Spindle Speeds (RPM): 150-4,200
- Motor: 1-1/2 HP

Item #
JEJPD-20MF



C.S. UNITEC, INC.
Portable Electric Hacksaw



- Ideal for cutting of pipe, structural steel, tanks and other materials
- Compact size, ideal for cutting in confined spaces
- 2-3/8" blade stroke
- Pipe clamps for 90° cutting of up to 24" OD pipe; profile clamps for structural steel
- Optional blade guide to ensure right-angle cuts

Item #	Desc.	Amps/Volts	Stokes Per Min
UC5-1215-0070	1.5 HP, w/ trigger throttle	11/110	200-400

C.S. UNITEC, INC.
Portable Electric Bandsaws



- Capacity: 7"; 5.8 Amps
- Ideal for plumbing and mechanical contractors, as well as demolition and plant maintenance; fast on-site cutting
- Heavy-duty variable-speed motors operate on 110VAC; with stainless steel housing and planetary gearbox cut up to 7" OD
- Speed: 100-245 RPM

Item #
UC5-6047-0010



C.S. UNITEC, INC.

Pneumatic Cutoff Saw

- Hand-held 14" saw cuts concrete, asphalt, masonry, steel
- Wet or dry cutting
- Low maintenance - no belts, pistons, fuel lines or carburetors
- Accept diamond or abrasive blades
- Adjustable blade guard with built-in water connection
- In-line oiler for motor lubrication
- 1" arbor size, 1/2" NPT air connection



Item #	Power HP	Max Depth of Cut (in.)	Max. Blade Cap. (in.)	CFM @ 100 psi
UCCSH-100	5	4	14	90

C.S. UNITEC, INC.

Portable Magnetic Drill

- Drills up to 2" diameter holes with annular cutters, 7/8" diameter twist drill capacity
- Strong 10.5 Amp motor and two-speed gearbox
- HD dual-coil magnet has holding strength of 3750 lbs.
- Easy "twist and lock" keyless arbor for cutters
- Compact height of 16-1/2" allows drilling in small spaces



Item #	Power	Speed (RPM)	Arbor Bore (in.)
UCECO-50	10.5 Amp/ 110 Volt	Gear 1: 250, Gear 2: 450	3/4

C.S. UNITEC, INC.

Pneumatic Rotary Hammer

- Uses SDS-Max Shank Drill Bits
- Holes up to 1" diameter with solid carbide tipped bits
- Up to 3" diameter with carbide core bits
- Fast impact drilling of anchor holes and thru holes for concrete and masonry
- Safer than electric in hazardous atmospheres and wet environments
- Designed for use in refineries, chemical plants, utilities, construction and heavy industry



Item #	Speed RPM	BPM	Power/Consumption @ 90 PSI	Connection (in.)
UC2-2414-0010	0-625	0-3000	0.7 HP/21 CFM	1/2 I.D.

C.S. UNITEC, INC.

Heavy-Duty Concrete Grinder

With Dust Extraction



- Remove paint, epoxy, glue and other hard coatings
- Clean concrete before applying new paint or coatings
- Long power tool life due to the new motor arrangement
- Grinds into corners and edges because of removable front dust guard
- Efficient dust exhaust outlet

Item #	Dia. (in.)	Speed (RPM)	Power Consumption
UCEBS-125-D	5	10,000	14 Amps/ 1500 Watts



HOUGEN MFG., INC.

Ultra Low Profile Magnetic Drill

- Ultra Low Profile - fits in the tightest of spots. Only 6-11/16" height
- Uses RotaLoc™ cutters which requires no tools for installation or removal
- Positive slug ejection
- High torque gearing
- Feed handles lock for easy maneuverability
- Ratchet or wrench can be used in place of handles
- Rear mounted controls



Item #	Dia. (Min/Max)	Depth (in.)	Motor	Speed (RPM)
HGHMD115	1/2" - 1 1/16"	3/4"	7.2A	450

HOUGEN MFG., INC.

Low Profile Magnetic Drill

- Uses RotaLoc Plus™ cutters which requires no tools for installation or removal
- Positive slug ejection
- High torque gearing
- Lift detector safety system
- Feed handle switches easily from side to side
- Ratchet or wrench can be used in place of feed handle
- Rear mounted controls



Item #	Dia. (Min/Max)	Depth (in.)	Motor	Speed (RPM)
HGHMD150	1/2" - 1 3/8"	1	7.2A	450



HOUGEN MFG., INC.

Portable Magnetic Drills

- Positive slug ejection
- Feed handles quickly change from side to side
- Gravity fed coolant system
- Swivel Base adds even greater versatility
- Great for horizontal, overhead, tight areas, and getting out over another piece of steel



Item #	Dia. (Min/Max)	Depth (Max)	Motor	Speed (RPM)	Arbor
HGHMD904C	7/16" to 2 1/2"	2"	7.2A (120V), 3.6A (230V)	450	Spring ejected
HGHMD925	7/16" to 1 1/2" (1 1/4" Pwr. Fd.)	2"	7.2A	450	Spring
HGHMD914	7/16" to 2 1/16"	3"	10.5A	350	Spring

1/2" **Low Buck Chuck with Key**

HG10731

HOUGEN MFG., INC.

Multi-Speed Portable Magnetic Drills

HMD 505 Features:

- Two speed gear box - 250 & 450 RPM
- Positive slug ejection
- Two stage magnet. Engages full power when motor is turned on
- Feed handles quickly change from side to side
- Lift detector safety system
- Rear mounted controls
- Coolant bottle included
- Optional pressurized coolant system available



HMD915 Features:

- Interchangeable gears for up to seven speeds (120/332 RPM included), (100, 120, 142, 200, 279, 332 and 400 RPM available)
- Uses Rotabroach "42/43,000-Series" Cutters
- Can use "12,000-Series" Cutters with adapter (Included) - (Part No. 40040)
- Positive slug ejection
- Feed handles quickly change from side to side
- Coolant bottle included
- More holding power with impactor points
- Lift detector safety system
- Chip breaker

Item #	Dia. (Min/Max)	Depth (in.)	Motor
HGHMD505	7/16" - 2 3/8"	3	13A
HGHMD915	3/4" - 3 1/16"	3	10A

HOUGEN MFG., INC.
Electro Hydraulic Hole Punch
Punch-Pro™



This heavy-duty model is built for punching up to 7/8" diameter holes in materials up to 3/8" thick. The addition of eyebolts on both sides of the unit allows for easy attachment of a lift assist or a counter-balancer for improved ergonomics. Its 3-15/16" throat depth adds to its versatility covering a wide range of work pieces. Easily confirm the hole position with the jog down feature. Punch automatically returns to the starting position after the punching cycle is complete. Work stand, foot switch, 13/16" punch & (2) dies and tool kit are included

- Approximate Punching Speed: 3 seconds

Item #	Pressure (Tons)	Maximum Hole Size - Round	Maximum Hole Size - Oblong	Motor
HG75005	27.5	7/8"	1 1/16" x 1 3/16"	12.2 A

Edge rents and repairs Magnetic Drills.

We can also sharpen your annular cutters.



HOUGEN MFG., INC.
Annular Cutters

"12,000-SERIES"
Rotabroach®



- Made of hardened high speed tool steel; cutters are resharpenable
- Require less horsepower and thrust to cut, and last much longer than traditional hole-making methods
- Feature a 3/4" diameter double-flatted shank and are available in 1, 2, and 3" D.O.C.
- Made in the USA

Item #	Cutter Dia. (in.)	Decimal Equivalent
--------	-------------------	--------------------

1" Depth of Cut

HG12114	7/16	.4375
HG12116	1/2	.5000
HG12118	9/16	.5625
HG12120	5/8	.6250
HG12122	11/16	.6875
HG12124	3/4	.7500
HG12126	13/16	.8125
HG12128	7/8	.8750
HG12130	15/16	.9375
HG12132	1	1.0000
HG12134	1 1/16	1.0625
HG12136	1 1/8	1.1250
HG12138	1 3/16	1.1875
HG12140	1 1/4	1.2500
HG12142	1 5/16	1.3125
HG12144	1 3/8	1.3750
HG12146	1 7/16	1.4375
HG12148	1 1/2	1.5000
HG12150	1 9/16	1.5625
HG12152	1 5/8	1.6250
HG12154	1 11/16	1.6875
HG12156	1 3/4	1.7500
HG12158	1 13/16	1.8125
HG12160	1 7/8	1.8750
HG12162	1 15/16	1.9375
HG12164	2	2.0000

2" Depth of Cut

HG12214	7/16	.4375
HG12216	1/2	.5000
HG12218	9/16	.5625
HG12220	5/8	.6250
HG12222	11/16	.6875
HG12224	3/4	.7500
HG12226	13/16	.8125
HG12228	7/8	.8750
HG12230	15/16	.9375

Item #	Cutter Dia. (in.)	Decimal Equivalent
HG12232	1	1.0000
HG12234	1 1/16	1.0625
HG12236	1 1/8	1.1250
HG12238	1 3/16	1.1875
HG12240	1 1/4	1.2500
HG12242	1 5/16	1.3125
HG12244	1 3/8	1.3750
HG12246	1 7/16	1.4375
HG12248	1 1/2	1.5000
HG12250	1 9/16	1.5625
HG12252	1 5/8	1.6250
HG12254	1 11/16	1.6875
HG12256	1 3/4	1.7500
HG12258	1 13/16	1.8125
HG12260	1 7/8	1.8750
HG12262	1 15/16	1.9375
HG12264	2	2.0000
HG12266	2 1/16	2.0625
HG12268	2 1/8	2.1250
HG12270	2 3/16	2.1875
HG12272	2 1/4	2.2500
HG12274	2 5/16	2.3125
HG12276	2 3/8	2.3750

3" Depth of Cut

HG3-12224	3/4	.7500
HG3-12226	13/16	.8125
HG3-12228	7/8	.8750
HG3-12230	15/16	.9375
HG3-12232	1	1.0000
HG3-12234	1 1/16	1.0625
HG3-12236	1 1/8	1.1250
HG3-12238	1 3/16	1.1875
HG3-12240	1 1/4	1.2500
HG3-12242	1 5/16	1.3125
HG3-12244	1 3/8	1.3750
HG3-12246	1 7/16	1.4375
HG3-12248	1 1/2	1.5000
HG3-12250	1 9/16	1.5625
HG3-12252	1 5/8	1.6250
HG3-12254	1 11/16	1.6875
HG3-12256	1 3/4	1.7500
HG3-12258	1 13/16	1.8125
HG3-12260	1 7/8	1.8750
HG3-12262	1 15/16	1.9375
HG3-12264	2	2.0000
HG3-12266	2 1/16	2.0625
HG3-12268	2 1/8	2.1250
HG3-12270	2 3/16	2.1875
HG3-12272	2 1/4	2.2500
HG3-12274	2 5/16	2.3125
HG3-12276	2 3/8	2.3750



HOUGEN MFG., INC.

Annular Cutter Pilot Bits

Rotabroach®

- Helps to locate the holes center point
- Initiates coolant flow to the center of the tool
- Ejects the slug at the end of the cut



Item #	Depth of Cut (in.)	Used For Cutter Size
HG10531	1	7/16"
HG10533	1	1/2" - 11/16"
HG10527	1	3/4" - 23/8"
HG10532	2	7/16"
HG10534	2	1/2" - 11/16"
HG10528	2	3/4" - 23/8"
HG24131	3	3/4" - 23/8"



BLACK & DECKER

12 Gallon Dust Extractor with VCS

Dewalt

- Tank Size: 12 gal.
- Amps: 9 Amps
- Max. CFM: 129 CFM
- Water Lift: 83"
- Automatic Filter Clear
- Decibel: 70 dBA
- Variable-Speed Dial
- Power Cord: 21 ft.
- Hose Diameter: 1-1/4"; Hose Length: 14'



Item #

DTD27904

BLACK & DECKER

10 Gallon Dust Extractor Vacuum

- Tank Size: 10 gal.
- Amps: 9 Amps
- Max. CFM: 129 CFM
- Water Lift: 83"
- Decibel: 70 dBA
- Variable-Speed Dial
- Power Cord: 21 ft.
- Hose Diameter: 1-1/4"; Hose Length: 14'



Item #

DTD27905

BLACK & DECKER

Dust Extractor 5 Piece Accessory Kit

Dewalt

- Enables you to get full use out of your DeWalt® Dust Extractor Vacuum
- Includes floor squeegee, crevice tool, 2 extension wands, curved wand and an accessory bag



Item #

DTD279059

BLACK & DECKER

Paper Filter Bag

For DTD27904

Dewalt



Item #

DTD279042

BLACK & DECKER

Fleece Filter Bag

For DTD27904

Dewalt



Item #

DTD279042F

BLACK & DECKER

Paper Filter Bag

For DTD27905

Dewalt



Item #

DTD279052

BLACK & DECKER

Fleece Filter Bag

For DTD27905

Dewalt



Item #

DTD279052F



FEIN POWER TOOLS, INC.

Turbo I Vacuum

Turbo I is quiet, powerful and portable. Whether you use it as a shop vac or as part of a dust-free sanding system, the Turbo I is perfect for the shop as well as the home.

- Auto start
- Variable suction
- Voltage: 120 V
- Static water lift: 90"
- Air flow: 116 cfm
- Hose length: 16 ft.; Hose diameter: 1-1/4"
- Capacity dry: 6 gal.; Capacity wet: 5.3 gal.



Item #
FN9-20-24

FEIN POWER TOOLS, INC.

Turbo II Vacuum

Turbo II is our most popular model, the original workhorse of the line. It features more power and greater capacity.

- Auto start
- Variable suction
- Voltage: 120 V
- Static water lift: 90"
- Air flow: 116 cfm
- Hose length: 16 ft.; Hose diameter: 1-1/4"
- Capacity dry: 9 gal.; Capacity wet: 6.8 gal.



Item #
FN9-20-25

FEIN POWER TOOLS, INC.

Turbo III Vacuum

Turbo III has a hefty 15 gallon capacity and even more power for the big jobs. It comes with a 2-1/4" hose and doubles as a clean and efficient workshop dust collector.

- Auto start
- Variable suction
- Voltage: 120 V
- Static water lift: 99"
- Air flow: 126 cfm
- Hose length: 10 ft.; Hose diameter: 2-1/4"
- Capacity dry: 15 gal.; Capacity wet: 12 gal.



Item #
FN9-20-26



NILFISK Hepa Vacuum

Attix 50



- Push and clean with filter cleaning button
- Washable pet fleece filter
- 12 gallon container
- Accessories include: Hose, curved wand, 2 pc. extension tube, floor nozzle, crevice nozzle, brush nozzle, universal nozzle

Item #
NK900131

NILFISK Filter Bags

- Filter bag for Attix 8 and 12
- Pack of 5



Item #
NK302001492



DUSTLESS TECHNOLOGIES Dustless Vacuum Cleaners

Wet/Dry and HEPA



- Powerful 23,000 RPM 11.5 amp electric motor
- 16 gallon capacity
- High impact tank for years of trouble free use
- Patented filter system provides three layers of filtration
- Optional micro pre-filter captures down to .5 microns
- Clean filters without opening canister
- Filters may be cleaned without removing the lid
- No need to change the filter when switching from a dry to wet (the filters never get wet)
- Primary and secondary filters are machine washable synthetic fabric

Item #	Desc.
DL16003	Wet/Dry Model
DL16006	HEPA Model

Accessories

DL13001	W/D Filter Package
DL13151	Micro Pre-Filter Bag
DL13201	HEPA Filter



SHOP VAC CORP.

Wet/Dry Ultra Pump Vacuums



- Cord Length: 18 Ft.
- Operation Sound Level: Super/Extra Quiet
- Hose Size: 2.5" Diameter (1.25" & 2.5" for 960-97-10)
- Tank Drain; Blower Feature
- Lock-on Hose; Onboard Accessory Storage
- Built In Water Pump
- Includes: 2-1/2" Dia. X 8' Lock-On hose, (2) 2-1/2" ext. wands, 14" floor nozzle, 8" utility nozzle, crevice tool, concentrator nozzle, elbow grip, foam sleeve, cartridge filter & disposable filter bag

Item #	Capacity (Gal.)	Peak H.P.	CFM
SH960-14-00	14	5.5	190
SH960-97-10	18	6.5	200

SHOP VAC CORP.

Wet/Dry Vacuum



- Stainless steel tank; oversize on board tool storage
- Easy reach switch; convenient side carrying handles
- Super-quiet motor; Up to 6.5 peak HP bypass motor
- Tank drain; high quality cartridge filter for wet or dry pickup
- Heavy duty 2-1/2" hose and tools; high quality drywall collection bag for fine dust pick up
- Included Accessories: 6'x2-1/2" heavy duty hose; 2 - 2-1/2" extension wands; 8" utility nozzle; 14" floor nozzle with squeegee; crevice tool; high quality cartridge filter, and drywall filter bag

Item #	Capacity (Gal.)	Peak H.P.	CFM
SH925-45	10	6.5	175

SHOP VAC CORP.

Wet/Dry Vacuum



- Poly tank; oversize on board tool storage
- On-board cord wrap; 18' power cord
- Easy reach switch; super-quiet motor
- Large top carrying handle; convenient side carrying handles
- Tank drain; high quality cartridge filter for wet or dry pickup
- Heavy duty 2-1/2" hose and tools; high quality drywall collection bag for fine dust pick up
- Easy roll caster system; anti tip design
- No changing messy filters; no blow through when picking up dry-wall dust
- Included Accessories: 6'x2-1/2" heavy-duty hose; 2 - 2-1/2" extension wands; 8" utility nozzle; 14" floor nozzle with squeegee; crevice tool; high quality cartridge filter, and drywall filter bag

Item #	Capacity (Gal.)	Peak H.P.	CFM
SH925-40	10	4.0	130
SH925-41	12	5.0	165
SH925-42	16	6.25	170

SHOP VAC CORP.

Cartridge Filter for Wet/Dry Pickup

- Fits full size vacs
- Approximate size of cartridge: 8" diameter and 6.5" high
- For small, dry debris and wet materials



Item #

SH903-04-7

SHOP VAC CORP.

HEPA Cartridge Filter

- For High Efficiency Particulate Air filtration that's 99.97% efficient down to 0.3 microns
- Use for dry pickup only
- Foam sleeve protects filter from being damaged by larger debris
- Approximate size of cartridge: 8" diameter and 6.5" high



Item #

SH903-34-00

SHOP VAC CORP.

Foam Sleeve for Vacuums

- Use the foam sleeve for picking up wet messes when used alone
- The foam sleeve is also required when using reusable disc style filters
- Approximate size of sleeve: 8" diameter and 6.5" high



Item #

SH905-85-00

SHOP VAC CORP.

Super Performance Dacron® Cloth Filter

- Must be used in combination with a 905-85 foam sleeve
- Made from durable Dacron® material, this cloth filter can be washed and reused to help save you both time and money
- Perfect for pick-up of larger debris and dry material



Item #

SH901-15-7

SHOP VAC CORP.

Reusable Disc Filters with Mounting Ring

- Must be used in combination with a 905-85 foam sleeve
- Just wash and reuse, again and again
- Comes in a package of three with easy to use mounting ring for pick-up of larger debris and dry material



Item #

SH901-07-00



SHOP VAC CORP.
Vacuum Cleaner Filters

- For use with the Hippo@Vac. Disposable filter bags plus prefilter (5 pack)



Item #	Desc.
SH901-46-2	Disposable bags plus prefilter

SHOP VAC CORP.
Drywall Collection Filter Bags

- Specially designed for pick-up of fine dust like drywall and cement dust or cold ashes, these high quality, disposable filter bags
- (2) per pack



Item #	Desc.
SH906-72-62	Fits 10-14 Gal Vacs
SH906-73-00	Fits 16-22 Gal Vacs

SHOP VAC CORP.
Drywall Collection Filter Bags

Dual-Ply

- Specially designed for pick-up of fine dust like drywall and cement dust or cold ashes, these high quality, disposable filter bags
- (5) per pack



Item #	Desc.
SH919-06-10	Fits 10-14 Gal Vacs
SH919-07-10	Fits 16-22 Gav Vacs

SHOP VAC CORP.
Vacuum Hoses

- 8' x 2-1/2" diameter
- Large diameter helps prevent clogs when vacuuming bulky debris
- Excellent for bulky dry material like wood shavings



Item #
SH905-03-4

SHOP VAC CORP.
Crushproof Vacuum Hoses

- 12' x 1-1/2" diameter
- All purpose hose for industrial use
- Black, heavy-duty



Item #
SH905-66-1

SHOP VAC CORP.

Vacuum Hose Converter

- Allows you to use 2-1/2" accessories with a 1-1/2" hose



Item #
SH906-49-5

SHOP VAC CORP.

Vacuum Hose Coupling

- Allows you to connect two 2-1/2" hoses together



Item #
SH906-86-7



RIDGE TOOL CO.
12 Gallon Wet/Dry Vac

High Performance

- 5.0 Peak HP Motor
- 12 Gallon drum provides capacity for clean-up of large spills
- On-board Accessory Storage
- 1-Layer Standard pleated paper filter
- Powerful 160 MPH exhaust airstream can be directed through the vac hose to blow sawdust from tools and debris from garages, decks and sidewalks
- Includes: 2-1/2" x 7' Tug-A-Long® Locking Hose, 2 Extension Wands, Utility Nozzle, Car Nozzle, Wet Nozzle, 1-Layer Paper Pleated Filter and owner's manual
- Motor: Air Watts: 270; CFM: 176; Amps: 10.0; Accessory Size: 2-1/2"



Item #
RI31668

NIKRO INDUSTRIES INC.
Portable Air Scrubber

- Light weight, dent and corrosion resistant portable polyethylene air scrubber
- Features:

- 2-speed blower for controlled air flow
- 3-stage filtration with 99.97% @ 0.3 micron HEPA filter
- Filter monitoring gauge
- Hour meter
- 12" exhaust hose flange
- Stackable nesting feature for easy transporting and storage
- Locking casters and side carrying handles
- 2000 CFM (Free Air)
- 115v / 10 amps



Item #
NOPS2009



NIKRO INDUSTRIES INC.
Portable Air Scrubber

- Economical high performance unit features a 2-speed blower for controlled air flow
- 3-stage filtration with 99.97% @ 0.3 micron HEPA filter
- Filter monitoring gauge; hour meter
- 12" exhaust hose flange; 4-caster design and side carrying handles
- The cabinet housing is aluminum with fully welded seams and powder coat paint finish
- 2000 CFM (Free Air); 115v / 11 amps



Item #
NOSC2005

NIKRO INDUSTRIES INC.
Air Scrubber Accessories



- Intake and outlet hoses and adapters for Nikro Air Scrubbers

Item #	Description
NO860243	12"x25' Mylar Intake and Exhaust Hose
NO860249	12" Quick Connect Hose Clamp
NO860139	12" Hose-Hose Connector

NIKRO INDUSTRIES INC.
Filters for Portable Air Scrubbers



- Multi-use filters for Nikro Air Scrubbers

Item #	Size	Description
NO550048	24"x24"x2"	Tri-Pleat Filter
NO550047P	24"x24"x1"	Blue Pre-Filter
NO550046	24"x24"x12"	Hepa Filter



OMNITEC DESIGN INC.
HEPA Negative Air Machines

Omniaire 2000V

Air scrubber for removal of toxic mold, asbestos and lead dust during renovation and abatement projects.



- Comes standard with a particle board 99.97% 0.3 HEPA filter and can be upgraded to a metal frame 99.97% 0.3 HEPA filter
- Dimensions (LxWxH): 34"x20"x29"
- Airflow Ratings (cfm): 300 to 1900 (airflows based on blower manufacturer curves. Different HEPA filters may cause the flow to vary)
- Filtration Stages: 3 to 5; Exhaust Collar Diameter: 12"
- Motor: 1 hp with thermal overload; Max. Operating Amps: 12.0

Item #
OA2000V

OMNITEC DESIGN INC.
HEPA Negative Air Machines

Omniaire 2200C

The Omniaire 2000C is a construction grade machine. It delivers the performance of full sized negative air units but is easy to move and set up. Equipped with a 99.97% HEPA filter and 2-stage prefilter, it is used on asbestos, lead and mold abatement projects. The HEPA filter can be replaced with an economical 95% ASHRAE Bag Filter to collect bulk dust from cutting and grinding of concrete, wood and plaster.



- Dimensions (LxWxH): 34"x26"x31"
- Airflow Ratings (cfm): 1000, 2000 (airflows based on blower manufacturer curves. Different HEPA filters may cause the flow to vary)
- Filtration Stages: 3 to 5
- Exhaust Collar Diameter: 12"
- Motor: 1 1/4 hp with thermal overload; Max. Operating Amps: 13.8

Item #
OA2200C

OMNITEC DESIGN INC.
HEPA Negative Air Machines

Omniaire 2200UL

Air scrubber for removal of toxic mold, asbestos and lead dust during renovation and abatement projects.



- Dimensions (LxWxH): 34"x26"x31"
- Airflow Ratings (cfm): 1000, 2000 (airflows based on blower manufacturer curves. Different HEPA filters may cause the flow to vary)
- Filtration Stages: 3 to 5
- Exhaust Collar Diameter: 12"
- Motor: 1 1/4 hp with thermal overload; Max. Operating Amp: 13.8

Item #
OA2200UL



DELTA CONSOLIDATED INDUSTRIES
1-1/2 HP Contractor's Saw

With 30" T2 Fence and Cast Iron Wings



- Blade tilts away from the fence (left tilt) in ripping applications to prevent tearout on the outside corner of a mitered joint
- Large cast-iron table with cast-iron extension wings measure a full 40-1/2" x 27" for maximum material support
- Mobile base attaches directly to wide-stance base for maximum saw support and mobility
- Deluxe T-Slot miter gauge with adjustable stops at 45° and 90°
- Powerful 1-1/2 HP induction motor handles tough cutting operations

Item #
DTDE36-980



DELTA CONSOLIDATED INDUSTRIES
Left Tilt Hybrid Saw

*With T2 Fence, 30"
Rail Tableboard*



- Left tilting blade tilts away from fence
- 45° and 90° bevel stops adjustable from the table top; deluxe miter gauge
- Oversized on/off switch with full overload protection

Item #
DTDE36-715

DELTA CONSOLIDATED INDUSTRIES
3 HP Motor 10" Unisaw®

*With 52" Biesemeyer®
Fence System*



- Dual front cranks make adjusting blade height and blade bevel easy, accurate, and repeatable in all your operations
- Biesemeyer® Fence System provides hairline pointer and built-in tape allowing you to make precision set-ups, cut after cut; 9-ply fence faces have improved tolerances like no other as well as an improved cam front lock lever for an over lock with a curved edge

Item #
DTDE36-L352

DELTA CONSOLIDATED INDUSTRIES
**12" Variable-Speed
Bench Drill Press**



- 1/3 HP Induction Motor for long-lasting, smooth performance
- Adjustable-position, locking depth stop for accurate depth measurement and repetitive drilling
- Tilting table with slots for fast clamping of work
- Standard 3-jaw, 1/2" capacity chuck for positive gripping of various drill press cutting tools

Item #
DTDEDP350

DELTA CONSOLIDATED INDUSTRIES
17" Laser Drill Press



- Fully adjustable laser pod projects a crosshair on the work piece to indicate the location of bit contact
- Woodworker's table has a removable insert for through drilling with large bits and accommodates sanding drums as well
- Unique table is designed to eliminate auxiliary fixtures by tilting left, right and forward
- Heavy-duty 3/4 HP motor provides ample power for demanding applications

Item #
DTDE17-959L

DELTA CONSOLIDATED INDUSTRIES
**4" Quick-Release
Drill Press Vise**



- Holds wood and metal work pieces up to 4" wide
- Built-in groove holds dowels and other round materials

Item #
DTDE20-622

DELTA CONSOLIDATED INDUSTRIES
14" Band Saw

With 1 HP Motor and Enclosed Stand



- Full 16"x16" cast-iron table tilts 45° right and 3° left for beveling operations
- Capacity to cut stock up to 6-1/4" thick (12-1/4" with height attachment)
- Two-speed pulley position

Item #
DTDE28-206

DELTA CONSOLIDATED INDUSTRIES
6" Professional Jointer



- Delta's 6" professional jointer makes it easy with a 1 HP motor, rack and pinion fence system, three-knife cut-terhead and easy-to-position infeed table

Item #
DTDE370275X

DELTA CONSOLIDATED INDUSTRIES
12-1/2" Variable-Speed Midi-Lathe®



- Powerful 1 HP max, 1,725 rpm motor
- Large 12-1/2" swing capacity provides the largest capacity in its class
- Electronic Variable Speed with three-pulley speed ranges provide the required speeds needed to turn a project without changing belt position
- Includes 3" face plate, 6" tool rest and 10" tool rest - Turning long spindles require either a longer tool rest or the user to continually move the short tool rest; turning short work requires a short spindle; the long spindle will not allow the turner to get close enough to the piece
- Extension Bed (Model 46-463) is a 25-1/2" long cast-iron bed that increases the overall bed length of the 46-460 to 42"

Item #
DTDE46-460



DELTA CONSOLIDATED INDUSTRIES
6" Variable-Speed Grinder

With Tool-less Quick Change

- Variable-speed grinder with tool-less quick change with a 2 amp, 120V/60Hz, 2000-3450 RPM induction motor
- Flexible lamp
- Tool rests
- Eye shields
- Spark deflectors
- Grinding and white friable sharpening wheels
- Wrench and diamond
- Wheel dresser and instruction manual



Item #

DTDEGR275

DELTA CONSOLIDATED INDUSTRIES
8" Variable-Speed Grinder

With Tool-less Quick Change

- Variable-speed grinder with patent pending tool-less quick change with a 5-amp, 60 Hz, 1725-3450 RPM, single phase motor
- Patent pending quick change/tool-less wheel changing system
- Flexible lamp
- Cast iron tool rest
- Eye shields
- Spark deflectors
- Coarse, friable, buffing wheels
- Diamond wheel dresser



Item #

DTDEGR450

DELTA CONSOLIDATED INDUSTRIES
1 HP Motor Dust Collector 650 CFM

- 1 HP TEFC Induction motor for long-lasting, smooth performance
- 1 Micron top filter bag for superior fine dust filtration
- Clear disposable bottom bags for fill and toss convenience



Item #

DTDE50-720

DELTA CONSOLIDATED INDUSTRIES
Carbide Tipped Blades



- Fine-grain industrial carbide tips highly-ground for smooth finish and long life
- Large carbide tips can be re-sharpened up to 15 times
- Chrome-alloy steel body with heavy kerf, balanced for running accuracy
- Expansion slots to dissipate heat, reduce noise level, and prevent warping

Item #	Material Type	Size (in.)	Teeth	Tooth Type
DTDE35-7640	Natural woods, plywood, particle board, and MDF	10	50T	ATB+R
DTDE35-7645	Softwoods, hardwoods, plywood and veneer laminates	10	60T	ATB
DTDE35-7646	Softwoods, hardwoods, plywood and veneer laminates	10	60T	ATB
DTDE35-7647	Softwoods, hardwoods, plywood, and veneer laminates	10	80T	ATB
DTDE35-7648	Softwoods, hardwoods, plywood and veneer laminates	12	60T	ATB
DTDE35-7660	Laminates, MDF, and particle board	10	80T	TCG
DTDE35-7662	Melamines and veneers	10	80T	H-ATB
DTDE35-7666	Aluminum, brass, other non-ferrous metals	12	80T	TCG

DELTA CONSOLIDATED INDUSTRIES
8" Stacked Dado Set



- Micro-grain carbide teeth deliver clean cuts and reduce splintering
- 4-Tooth chippers give smooth, flat bottom cuts
- Stainless-steel shims allow for ultra-fine width adjustments

Item #

DTDE35-7670

PORTER-CABLE

PORTER CABLE

1/4 Sheet Palm Sander Kit

- 2.4 Amp motor for power and durability in the shop
- Porous polyethylene dust canister exceeds durability of cloth dust bags
- Dual dust ports accept 1" and 1-1/2" vacuum hoses



Item #

DTPC342K

PORTER CABLE

5" Low Profile

Random Orbit Sander Kit With Hook & Loop Pad

- 3.5 Amp EnduraTech Motor for increased performance and durability
- Electronic Load Control for 42% faster material removal
- Mechanical pad brake reduces free-spin to virtually eliminate gouging
- Low profile design reduces sander height by 31% for better control and finish
- Variable speed dial, 7,500 - 12,000 opm, optimizes removal rate on a variety of materials
- Integral dust port accepts 1" and 1-1/2" vacuum hoses for optimal dust collection



Item #

DTPC390K

PORTER CABLE

5" Random Orbit Sander Kit

- 3.0 Amp motor for power and durability in the shop
- Porous polyethylene dust canister exceeds durability of cloth dust bags
- Top cap design allows users to service or clean out the unit quickly
- Dual dust ports accept 1" and 1-1/2" vacuum hoses



Item #3

DTPC343K

PORTER CABLE

3" x 21" Variable-Speed Sander

- 8 Amp motor, AC only
- Variable-speed dial 850-1,300 SFPM
- Belt and gear drive system transfers power from the motor to the sanding belt
- Designed for flush sanding up to vertical surfaces
- Dust Bag Swivels 360°
- Fingertip belt-tracking knob



Item #

DTPC352VS

PORTER CABLE

3" x 24" Variable-Speed Sander

- Powerful 12 Amp motor
- Belt and gear drive system transfers power from the motor to the sanding belt
- Variable-speed dial is conveniently placed on the handle, allowing belt speed adjustment from 1,000 to 1,500 SFPM
- Quick-release belt-change lever
- Fingertip belt-tracking knob for quick, accurate belt adjustments
- Large capacity dust collection bag swivels 360°



Item #

DTPC360VS

PORTER CABLE

4" x 24" Variable-Speed Belt Sander

- Powerful 12 Amp motor provides professional power
- Variable-speed dial is conveniently placed on the handle, allowing belt speed adjustment from 1,000 to 1,500 SFPM
- Quick-release belt-change lever
- Fingertip belt-tracking knob for quick, accurate belt adjustments
- Large capacity dust collection bag swivels 360°



Item #

DTPC362V

PORTER CABLE

Laminate Trimmer

- Durable 5.6 Amp, 30,000 rpm motor
- Perfect for most trimming, small edge forming and hinge routing applications
- Micro-set™ adjustment knob enables quick and accurate bit-depth setting
- Spindle lock feature allows for single wrench bit changes
- Fixed base design allows for excellent bit visibility
- 1/4" collet



Item #

DTPC7310

PORTER CABLE

Offset Laminate Trimmer

- Durable 5.6 Amp, 30,000 rpm motor
- Offset base enables backsplash trimming, scribing to wall and trimming of 90° corners
- Precision cast aluminum base provides long-term durability
- Dust-sealed switch and sealed ball bearing construction enhance tool durability
- 1/4" collet



Item #

DTPC7312



PORTER+CABLE

PORTER CABLE *Deluxe Laminate Trimmer Kit*

- Durable 5.6 Amp, 30,000 rpm motor
- Perfect for most trimming, small edge forming and hinge routing applications
- Micro-set™ adjustment knob enables quick and accurate bit-depth setting
- Fixed base design allows for excellent bit visibility
- Offset base enables backsplash trimming, scribing to wall and trimming of 90° corners
- Precision cast aluminum base provides long-term durability
- 1/4" collet



Item #

DTPC97311

PORTER CABLE

1-3/4 HP (Maximum Motor HP) Router

- 11 Amp motor producing 1-3/4 Peak HP
- 27,500 rpm single speed motor
- Cam lock lever enables simple coarse height adjustments and motor release (fixed base)
- Micrometer depth adjuster accurate to 1/128"
- Precision machined aluminum motor housing and base
- Collets included to accept 1/4" and 1/2" shank bits



Item #

DTPC690LR

PORTER CABLE

2-1/4 HP (Maximum Motor HP) Multi-Base Router Kit With Router Table Height Adjuster

- Soft-starting, 12 Amp motor features full-time electronic feedback that maintains motor speed through the toughest applications
- Variable-speed control feature (10,000 - 23,000 rpm) enables bit speed to be optimized for changing applications
- Release the motor, adjust bit height and clamp the motor from above the router table with model #75301 kit (included); fixed base only
- Depth rod with 6-position adjustable turret enables stepped or repeated plunge cuts
- Rack and pinion adjustment provides fine depth settings to 1/128" (fixed base only)
- Clear Lexan® sub-base provides improved durability and bit visibility
- Flat side on plunge base allows user to work in tighter spaces and provides a straight reference point
- Collets included to accept 1/4" and 1/2" shank bits



Item #

DTPC895PK

PORTER CABLE

3-1/4 HP (Maximum Motor HP) Five-Speed Router

- 15 Amp motor provides the power and durability necessary for the toughest applications
- Versatile, electronic five-speed motor with 10,000, 13,000, 16,000, 19,000, and 21,000 rpm settings accommodates various router bit cutting diameters and applications
- Soft-start feature reduces torque at start-up and motor maintains constant speed under load



Item #

DTPC7518

PORTER CABLE

Deluxe Plate Joiner Kit

- 7.0 Amp, 120 V, AC only, 10,000 rpm
- 1" O.D. dust port accepts standard bag or can be connected to a vacuum
- Fence tilts from 0° to 135° with positive adjustable stop at 90°
- Includes both 2" and 4" diameter blades for standard and face-frame biscuits
- Seven-position rotating depth stop for FF, #0, #10, #20, Simplex, Duplex, and Max (#6) biscuits
- Bale handle attached to fence, not motor, for greater stability and added control during cuts



Item #

DTPC557

PORTER CABLE

12" Deluxe Dovetail Jig Combination Kit

- Includes template 4211 for half-blind, rabbeted half-blind and sliding dovetails
- Includes template 4213 for through dovetails and box joints
- Includes template 4215 for miniature through and half-blind dovetails, and miniature box joints
- Template alignment lines and router bit depth gauges allow for quick, easy set-up
- Accommodates stock from 1/4" to 1-1/8" thick



Item #

DTPC4216

PORTER CABLE

Joining Biscuits

- Tube of plate joining biscuits

Item #	Desc.	Qty. Per Tube
DTPC5560	No. 0	150
DTPC5561	No. 10	125
DTPC5562	No. 20	100
DTPC5563	Face Frame	175



PORTER+CABLE

PORTER CABLE 11.5 Amp Quik-Change Tiger Saw

Variable Speed/Dual Action
Porter Cable

- Extra heavy-duty 11.5 AMP motor provides maximum power for all cutting applications
- Electronic variable speed, 0-2,600 SPM, maintains speed under load for smooth consistent cutting
- Full 1-1/8" cutting stroke length



Specifications:

- Strokes/Min: 0-2,600 spm
- Stroke Length: 1-1/8"
- Keyless Blade Clamp: Yes - Quik-Change™
- Orbital Action: Yes

Item #

PTC9748



ROUSSEAU

Table Saw Stand

Porta Max



- Rip capacity to 27"
- Comfortable 34-1/2" work height with HPL professional grade laminate on both sides of top
- Powder coated steel construction
- Fit most saws
- The heart of our Table Saw Stand is our highly accurate Fence System

Fence System Features:

- Constructed of 2" tubular steel

Item #

RU2700XL

ROUSSEAU

Miter Saw Stand

- 36" x 19.25" Platform
- Designed to fit saws with wider bases & sliding back fences
- Sturdy all-steel construction
- Powder coated finish
- Stop System Included
- Stable 3" industrial locking casters
- Quick release hinge
- Sturdy support wings



Item #

RU2875XL

ROUSSEAU

Miter Saw Stand

- Fold & Go
- Fits all saws
- 35.5" work height
- 16" x 32" mounting surface
- 13" Roller stands & bases with 12" overall stock support included
- Powder coated finish
- Positive locking hinge supports with unbreakable spring loaded leg catch
- 10" Pneumatic tires & adjustable levelers for uneven ground



Item #

RU2950

ROUSSEAU

Batter Board System

- Reusable
- Improve productivity
- Increase accuracy

System Includes:

- Powder coated steel batter boards
- Adjustable locking sliders
- String line

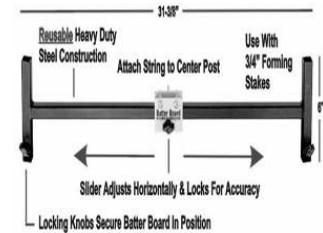

Item #

Desc.

RU4004	Set of 4
RU4008	Set of 8



POWERS FASTENERS

Carbide Drill Bits



Quatro™ Head SDS-Plus®

- Quatro™ Head SDS-Plus® carbide drill bits are designed to reduce vibration up to 60% and noise up to 30%
- These bits produce rounder and more accurately located anchor holes

Item #	Size (in.)	Usable Length (in.)
RL7094	1 1/8 x 18	16
RL7095	1 1/4 x 18	16



POWERS FASTENERS
Carbide Drill Bits

SDS-Plus® / S-4 Plus™

- Use in: Rotary hammer with SDS chuck or SDS adapter



Item #	Desc.	Size (in.)	Usable Length (in.)
RL0302		5/32 x 6	4
RL0304		3/16 x 4	2
RL0306		3/16 x 6	4
RL0308		3/16 x 8	6
RL0310		3/16 x 10	8
RL0312		3/16 x 12	10
RL0314		3/16 x 14	12
RL0320		1/4 x 4	2
RL0321		1/4 x 6	4
RL0322		1/4 x 8	6
RL0323		1/4 x 11	9
RL0324		1/4 x 14	12
RL0325		1/4 x 16	14
RL0327		1/4 x 20	18
RL0329		5/16 x 6	4
RL0331		5/16 x 12	10
RL0333		3/8 x 6	4
RL0334		3/8 x 8	6
RL0336		3/8 x 12	10
RL0338		3/8 x 18	16
RL0339		3/8 x 24	22
RL0341		7/16 x 6	4
RL0343		7/16 x 12	10
RL0346		1/2 x 6	4
RL0348		1/2 x 10	8
RL0349		1/2 x 12	10
RL0351		1/2 x 18	16
RL0352		1/2 x 24	22
RL0354		9/16 x 6	4
RL0355		9/16 x 10	8
RL0359		5/8 x 8	6
RL0361		5/8 x 12	10
RL0362		5/8 x 18	16
RL0364		1 1/16 x 8	6
RL0365		1 1/16 x 12	10
RL0368		3/4 x 8	6
RL0370		3/4 x 12	10

Item #	Desc.	Size (in.)	Usable Length (in.)
RL0371		3/4 x 18	16
RL0375		7/8 x 8	6
RL0376		7/8 x 12	10
RL0377		7/8 x 18	16
RL0379		1 x 8	6
RL0380		1 x 10	8
RL0381		1 x 12	10
RL0382		1 x 18	16
RL0394	Spline to SDS Adapter		
RL0396	SDS Max Adapter		

POWERS FASTENERS
Carbide Drill Bits

Quatro™ Head Spline

- Use In: Rotary hammer with spline chuck 
- The Quatro™ head design has four cutting faces which reduces vibration up to 60% and noise up to 30%; these bits produce rounder and more accurately located anchor holes

Item #	Size (in.)	Usable Length (in.)
RL7020	5/8 x 16	11
RL7021	5/8 x 23	18
RL7031	3/4 x 11	6
RL7033	3/4 x 16	11
RL7035	3/4 x 23	18
RL7036	3/4 x 27	22
RL7043	7/8 x 16	11
RL7045	7/8 x 23	18
RL7049	1 x 16	11
RL7051	1 x 23	18
RL7057	1 1/8 x 16	11
RL7059	1 1/8 x 23	18
RL7064	1 1/4 x 16	11
RL7066	1 1/4 x 23	18
RL7072	1 3/8 x 23	18
RL7077	1 1/2 x 23	18



POWERS FASTENERS
Carbide Drill Bits



Single Tip Spline

- Use in: Rotary hammer with spline chuck
- The bits are manufactured to conform with ANSI standard B212.15 and can be used to drill in concrete, block, brick, and soft stone; single tip head style is available
- These bits produce rounder and more accurately located anchor holes
- Std. Tube: 1

Item #	Size (in.)	Usable Length (in.)
RL1402	3/8 x 11	6
RL1403	3/8 x 16	11
RL1407	1/2 x 10	5
RL1409	1/2 x 16	11
RL1410	1/2 x 23	18
RL1412	1/2 x 27	22
RL1413	1/2 x 36	31
RL1420	5/8 x 16	11
RL1421	5/8 x 22	18
RL1433	3/4 x 16	11
RL1434	3/4 x 22	18
RL1436	3/4 x 27	22
RL1443	7/8 x 16	11
RL1444	7/8 x 22	18
RL1446	7/8 x 36	31
RL1449	1 x 16	11
RL1450	1 x 22	18
RL1457	1 1/8 x 16	11
RL1458	1 1/8 x 22	18
RL1464	1 1/4 x 16	11
RL1465	1 1/4 x 22 18	18
RL1470	1 3/8 x 16	11
RL1477	1 1/2 x 22	18
RL1490	2 x 22	18

POWERS FASTENERS
Carbide Drill Bits



SDS-Max®

- Use in: Rotary hammer with SDS-Max® chuck
- The bits are manufactured to conform with ANSI standard B212.15 and can be used to drill in concrete, block, brick, and soft stone
- Most SDS-Max® carbide drill bits have the Quatro™ head design which reduces vibration up to 60% and noise up to 30%

Item #	Size (in.)	Usable Length (in.)
RL8801	1/2 x 13	8
RL8802	1/2 x 21	16
RL8809	5/8 x 13	8
RL8810	5/8 x 21	16
RL8812	5/8 x 36	31
RL8817	3/4 x 13	8
RL8818	3/4 x 21	16
RL8820	3/4 x 36	31
RL8829	7/8 x 13	8
RL8830	7/8 x 21	16
RL8833	1 x 13	8
RL8834	1 x 21	16
RL8836	1 x 36	31
RL8843	1 1/8 x 15	10
RL8844	1 1/8 x 23	18
RL8846	1 1/4 x 15	10
RL8847	1 1/4 x 23	18
RL8848	1 1/4 x 36	31
RL8853	1 3/8 x 23	18
RL8859	1 1/2 x 23	18

POWERS FASTENERS
**Straight Shank
Hammer Drill Bits**



Heavy-Duty

- Heavy-duty straight shank carbide bits are designed for use in a hammer drill equipped with a 3 jaw jacobs type chuck; the bits meet ANSI standards and can be used to drill in concrete, block, brick, and soft stone

Item #	Drill Size (in.)	Usable Length	Shank Size (in.)
RL0501	1/8 x 3	2 1/4	1/8
RL0503	5/32 x 6	4	5/32
RL0504	3/16 x 4	2 3/4	3/16
RL0505	3/16 x 6	4	3/16
RL0512	1/4 x 4	2 3/4	1/4
RL0513	1/4 x 6	4	1/4
RL0514	1/4 x 12	10	1/4
RL0519	5/16 x 6	4	5/16
RL0522	3/8 x 6	4	3/8
RL0523	3/8 x 12	10	3/8
RL0531	1/2 x 6	4	3/8
RL0538	5/8 x 6	4	1/2
RL0545	3/4 x 6	4	1/2
RL0547	3/4 x 13	11	1/2



POWERS FASTENERS
Heavy-Duty Chisel
Spline Shank



- The chisels can be used for chipping applications in concrete, block, brick, and soft stone

Item #	Overall Length (in.)
RL0950	12
RL0951	18

POWERS FASTENERS
Heavy-Duty Chisel
SDS-Max Shank



- The chisels can be used for chipping applications in concrete, block, brick, and soft stone

Item #	Overall Length (in.)
RL0965	12
RL0966	18

POWERS FASTENERS
Heavy-Duty Chisel
Spline Shank



- The chisels can be used for chipping applications in concrete, block, brick, and soft stone
- Size or Width: 1-3/4" x 1-3/4"
- Overall Length: 10"

Item #
RL0960

POWERS FASTENERS
Heavy-Duty Chisel
SDS-Max Shank



- The chisels can be used for chipping applications in concrete, block, brick, and soft stone
- Size or Width: 1-3/4" x 1-3/4"
- Overall Length: 10"

Item #
RL0975

POWERS FASTENERS
Heavy-Duty Chisel
Spline Shank



- The chisels can be used for chipping applications in concrete, block, brick, and soft stone
- Size or Width: 1"

Item #	Overall Length (in.)
RL0952	12
RL0953	18

POWERS FASTENERS
Heavy-Duty Chisel
SDS-Max Shank



- The chisels can be used for chipping applications in concrete, block, brick, and soft stone
- Size or Width: 1"

Item #	Overall Length (in.)
RL0967	12
RL0968	18

POWERS FASTENERS
Heavy-Duty Chisel
3/4" Hex



- The chisels can be used for chipping applications in concrete, block, brick, and soft stone
- Size or Width: 1"

Item #	Overall Length (in.)
RL0982	12
RL0983	18

POWERS FASTENERS
Heavy-Duty Chisel
Spline Shank



- The chisels can be used for chipping applications in concrete, block, brick, and soft stone
- Size or Width: 5/8" & 3/4" Rod
- Overall Length: 10-1/2"

Item #
RL0959

POWERS FASTENERS
Heavy-Duty Chisel
SDS-Max Shank



- The chisels can be used for chipping applications in concrete, block, brick, and soft stone
- Size or Width: 5/8"
- Overall Length: 10"

Item #
RL0974

POWERS FASTENERS
Heavy-Duty Chisel
Spline Shank



- Heavy-duty chisels and accessories are designed for use in a combination rotary hammer/chipping tool equipped with a Spline, SDS-Max®, or 3/4" Hex chuck
- The chisels can be used for chipping applications in concrete, block, brick, and soft stone
- Overall Length: 12"

Item #	Size or Width (in.)
RL0954	1 1/2
RL0955	2



POWERS FASTENERS
Heavy-Duty Chisel

SDS-Max Shank



- The chisels can be used for chipping applications in concrete, block, brick, and soft stone
- Overall Length: 12"

Item #	Overall Length (in.)
RL0969	1½
RL0970	2



RELTON CORP.
Multi-Purpose Bit Kit

Rotary/Percussion
Groo-V™



- Specially designed for drilling granite and other extra-hard materials
- Has a serrated edge carbide allowing it to penetrate much faster than a standard masonry bit
- Kit Includes: 3/16", 1/4", 5/16", 3/8", 1/2"
- 6" bit length

Item #
REGRT-K5

RELTON CORP.
Rebar Cutters



- Carbide tipped
- Designed for use in 1/2" drill motor
- Intended for rotary drilling only

Item #	Diameter (in.)	Overall Length (in.)
RERB-6	3/8	8
RERB-8	1/2	12
RERB-9	9/16	12
RERB-10	5/8	12
RERB-12	3/4	12

Bit with Removable Shank

RERB-14	7/8	12
RERB-16	1	12
RERB-18	1 1/8	12
RERB-20	1 1/4	12
RERB-22	1 3/8	12
RERB-24	1 1/2	12
RERB-32	2	12

RELTON CORP.
SDS + Drop-in
Stop Bits



- Shoulder prevents over drilling - nice when overhead
- No lost time or energy drilling further than necessary
- Less likely to hit reinforcing steel or post-tensioned cable in concrete
- Anchor is set at specified depth, does not drop too far into hole

Item #	Diameter (in.)	Drilling Depth (in.)
	3/8	1-1/16
	1/2	1 3/16
	1/2	1-11/16
	5/8	1-3/16
	5/8	2-1/16

RELTON CORP.
Aluminum Cutting Fluids

A-9®



- Eases all operations on aluminum: milling, broaching, drilling, threading, tapping, reaming, sawing, etc.
- Contains anti-mist component for a healthier work environment
- Contains a scientific blend of chemicals that attach themselves to aluminum surfaces, forming an extreme-pressure boundary lubricant between tool and work surface

Item #	Desc.
RE4A9	4 Ounce Cans
RE16A9	Pint Cans
RE1A9	1 Gallon Bottles

RELTON CORP.
All-Metal Cutting Fluids

New Rapid Tap®



- Greatly extended tool life
- Super-fine machined finish in operation after operation
- Anti-mist protection for a healthier work environment
- No special labeling or reporting
- Excels in tough materials
- Contains no 1,1,1- trichloroethane or other ozone-depleting chemicals

Item #	Size
RE4RT	4 Ounce Can
RE16RT	Pint Can
RE1RT	1 Gallon Can



RELTON CORP.
Metal Cutting Fluids
Option 1®

- Option 1 leaves no oily residue
- Water-based
- No 1,1,1- trichloroethane or other ozone-depleting chemicals
- Cleans up with clean dry cloth or water
- Great for use in computer clean rooms, hospitals or when a weld operation follows machining operations



Item #	Size
RE01G-OP	1 Gallon Bottle

RELTON CORP.
Band-Saw Fluid Concentrate
Rel Saw™

- Improves blade life
- Stable over a wide variety of water conditions
- Promotes cleaner-running machines compared to soluble oils
- Reduces machine wear
- Long emulsion life
- Contains rust and corrosion inhibitors
- Fortified with boundary lubricants



Item #	Size
RE05G-RS	5 Gallon Pail

RELTON CORP.
Lubricating Stick Waxes
Stick-Kut™

- Safe and effective lubricant for grinding wheels, sanding belts and saw blades
- Eliminates heat build up and belt loading
- Extends wheel life
- Provides smooth, cool cutting
- Reduces loading, stops binding, and prevents burring



Item #	Size
RE15-SK	15 oz. Stick



BLACK & DECKER
Rotary Hammer Bits
SDS-Plus®
DeWalt



- Rock Carbide™ SDS Plus Bits
- Pilot-Point® tip starts on contact for greater accuracy
- Serrated titanium carbide tip provides extreme durability for longer drilling life
- Improved flute design pulls dust quickly for faster drilling

Item #	Dia. (in.)	Usable Length (in.)	Overall Length (in.)
DTDW5401	5/32	4 1/2	6 1/2
DTDW5402	3/16	2	4
DTDW5403	3/16	4 1/2	6 1/2
DTDW5404	3/16	6 1/2	8 1/2
DTDW5405	3/16	8	10
DTDW5407	3/16	12	14
DTDW5408	3/16	14	16
DTDW5410	7/32	4	6
DTDW5412	7/32	8	10
DTDW5417	1/4	4	6
DTDW5418	1/4	6 1/2	8 1/2
DTDW5420	1/4	10	12
DTDW5424	5/16	4	6
DTDW5427	3/8	4	6
DTDW5429	3/8	8	10
DTDW5431	3/8	16	18
DTDW5433	7/16	4	6
DTDW5435	7/16	10	12
DTDW5437	1/2	4	6
DTDW5438	1/2	8	10
DTDW5444	9/16	16	18
DTDW5449	5/8	22	24
DTDW5457	3/4	22	24
DTDW5464	1	8	10

BLACK & DECKER
Drive Chisels
SDS-Plus®
DeWalt



- For light chipping and chiseling with SDS rotary hammers

Item #	Desc.	Size (in.)	Wt
DTDW5349	Scraping Chisel	1 1/2 x 10	4
DTDW5348	Bull Point Chisel	10	1
DTDW5350	Cold Chisel	3/4 x 10	1



BLACK & DECKER
Carbide-Tipped Bits

Spline Shank
DeWalt



- Spline shank carbide-tipped bits; 22 Cutter head design

Item #	Dia. (in.)	Usable Lgth. (in.)	Overall Lgth. (in.)
DTDW5706	1/2	22	27
DTDW5709	5/8	5	10
DTDW5711	5/8	17	22
DTDW5712	5/8	22	27
DTDW5714	3/4	5	10
DTDW5717	3/4	22	27
DTDW5719	7/8	11	16
DTDW5720	7/8	17	22
DTDW5721	1	11	16
DTDW5722	1	17	22
DTDW5723	1	31	36
DTDW5724	1 1/8	5	10
DTDW5725	1 1/8	11	16
DTDW5726	1 1/8	17	22
DTDW5728	1 1/4	17	22
DTDW5729	1 3/8	11	16
DTDW5730	1 3/8	17	22
DTDW5732	1 1/2	17	22
DTDW5733	1 3/4	17	22
DTDW5734	2	17	22

BLACK & DECKER
Carbide Hammer Core Bits
DeWalt

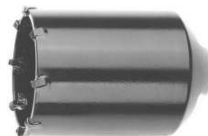

- Head design reduces friction and penetrates material quickly
- Alternating tooth design (pointed and flat) crushes concrete and removes debris
- Tungsten carbide teeth for maximum durability; hardened steel body resists breakage

Item #	Desc.
DTDW5900	1 1/2 in. x 4 in. Core Body
DTDW5901	2 in. x 4 in. Core Body
DTDW5902	2 1/2 in. x 4 in. Core Body
DTDW5903	3 in. x 4 in. Core Body
DTDW5904	3 1/2 in. x 4 in. Core Body
DTDW5905	4 in. x 4 in. Core Body
DTDW5906	5 in. x 4 in. Core Body
DTDW5907	Centering Bit
DTDW5909	7 in. Spline Shank
DTDW5910	16 in. Spline Shank
DTDW5911	7 in. SDS Max Shank

BLACK & DECKER
Masonry Shank
Rotary Hammer Bits

SDS-Max™ Carbide Tipped
DeWalt



- Fits SDS-Max™ rotary hammer drills
- Features include: Hardened core shank reduces breakage and double flute design gives quicker dust extraction and faster drilling Cutter head design:
- 4 cutter heads reduce vibration for less user fatigue and concave head design allows dust to enter flute chambers quickly increasing bit life (5/8 to 2" Dia.)

Item #	Usable Length (in.)	Dia.xLength
DTDW5803	8	1/2x13 1/2
DTDW5809	16	5/8x21 1/2
DTDW5807	31	5/8X36
DTDW5810	8	3/4x13 1/2
DTDW5813	31	3/4X36
DTDW5814	16	16
DTDW5815	8	7/8X13 1/2
DTDW5819	16	1x21 1/2
DTDW5820	31	1X36
DTDW5826	31	1 1/4X36
DTDW5827	18	1 1/2X22 1/2
DTDW5830	18	1 3/4X22 1/2
DTDW5831	18	2X22 1/2

BLACK & DECKER
Chipping & Chiseling Bits

SDS-Max™
DeWalt



- Fits SDS-Max™ rotary hammers

Item #	Desc.	Size (in.)
DTDW5837	Scaling Chisel	2x15
DTDW5833	Bull Point Chisel	12
DTDW5834	Cold Chisel	7/8x12



BLACK & DECKER

Concrete Chipping & Chiseling Tools

SDS-Max™
DeWalt



- Made from hardened steel to reduce breakage and provide long life
- For use with SDS Max rotary hammers
- For light chipping and chiseling of tile, mortar, glazing compounds, and other masonry products

Item #	Desc.
DTDW5832	12 in. Bull Point Chisel
DTDW5835	7/8 in. x 16 in. Cold Chisel
DTDW5835B15	7/8 in. x 16 in. Cold Chisel
DTDW5838	3 x 12 Scaling Chisel
DTDW5848B	Clay Spade
DTDW5843	1 3/8 x 12 Bushing Tool
DTDW5846	Asphalt Cutter
DTDW5847	Ground Rod Driver
DTDW5842	1 1/8 in. x 12 in. Slotting Chisel

BLACK & DECKER

Concrete & Masonry Demolition Hammer Bits

3/4" Hex Shank
DeWalt



- For 3/4" hex shank demolition hammers

Item #	Desc.	Size (in.)
DTDW5953	Flat Chisel	1x12
DTDW5954	Flat Chisel	1x20
DTDW5950	Moil Point Chisel	12
DTDW5951	Moil Point Chisel	20
DTDW5952	3 in. Wide Scaling Chisel	3x12
DTDW5958	Ground Rod Driver	3/4

BLACK & DECKER

Concrete Drivers & Chisels

Spline Shank
DeWalt



- DeWalt® demolition hammer steel is made from hardened steel to reduce breakage and provide long life
- For use with rotary hammers that accept 3/4" hex by 21/32" round shanks

Item #	Desc.
DTDW5773	1 1/2 in. x 12 in. Scaling Chisel
DTDW5774	2 in. x 12 in. Scaling Chisel
DTDW5785	5/8 in. - 3/4 in. Ground Rod Driver

BLACK & DECKER

Drill Bits

SDS-Plus®
DeWalt



- Pilot Point (R) tip starts on contact for greater accuracy
- Serrated titanium carbide tip breaks up material faster and provides extreme durability
- Improved flute design pulls dust quickly for faster drilling

Item #	Size	Usable Length (in.)
DTDW5401B25	5/32 x 6 1/2	4 1/2
DTDW5403B25	3/16 x 6 1/2	4 1/2
DTDW5406	3/16 x 10	8
DTDW5416	1/4 x 4	2
DTDW5416B25	1/4 x 4	2
DTDW5417B25	1/4 x 6	4
DTDW5418B25	1/4 x 8 1/2	6 1/2
DTDW5421	1/4 x 14	12
DTDW5424B25	5/16 x 6	4
DTDW5426	5/16 12	10
DTDW5427B25	3/8 x 6	4
DTDW5430	3/8 x 12	10
DTDW5432	3/8 x 24	22
DTDW5437B25	1/2 x 6	4
DTDW5439	1/2 x 12	10
DTDW5440	1/2 x 18	16
DTDW5441	1/2 x 24	22
DTDW5442	9/16 x 6	4
DTDW5443	9/16 x 12	10
DTDW5446	5/8 x 8	6
DTDW5447	5/8 x 12	10
DTDW5448	5/8 x 18	16
DTDW5450	1 1/16 x 8	6
DTDW5453	3/4 x 8	6
DTDW5455	3/4 x 12	10
DTDW5456	3/4 x 18	16
DTDW5460	7/8 x 8	6
DTDW5461	7/8 x 12	10
DTDW5462	7/8 x 18	16
DTDW5466	1 x 18	16



BLACK & DECKER
Drill Bit Set 5-Piece

SDS-Plus®
DeWalt



- Rock Carbide™ tip maximizes carbide surface contact for longer bit life
- Four flute design cleans debris out for fast, efficient drilling
- Includes: 3/16" x 4-1/2" x 6-1/2"; 1/4" x 2" x 4"; 1/4" x 4" x 6"; 3/8" x 4" x 6"; 1/2" x 4" x 6"

Item #
DTDW5470

BLACK & DECKER
Hammer Bits

Spline
DeWalt



- Hardened core reduces breakage
- Double flute removes material faster for more efficient drilling
- Concave head design allows dust to enter flute chambers quickly increasing bit life

Item #	Size	Usable Length (in.)
DTDW5700	3/8 x 10	5
DTDW5701	3/8 x 13	8
DTDW5703	1/2 x 10	5
DTDW5704	1/2 x 16	11
DTDW5705	1/2 x 22	17
DTDW5740	5/8 x 10	5
DTDW5741	5/8 x 16	11
DTDW5742	5/8 x 22	17
DTDW5746	3/4 x 10	5
DTDW5747	3/4 x 16	11
DTDW5748	3/4 x 22	17
DTDW5749	3/4 x 27	22
DTDW5752	7/8 x 16	11
DTDW5753	7/8 x 22	17
DTDW5755	1 x 22	17
DTDW5756	1 x 16	11
DTDW5757	1 x 36	31
DTDW5758	1 1/8 x 16	11
DTDW5759	1 1/8 x 22	17
DTDW5760	1 1/4 x 16	11
DTDW5761	1 1/4 x 22	17
DTDW5765	1 3/8 x 22	17
DTDW5764	1 1/2 x 22	17

BLACK & DECKER
Drive Accessories

Spline, Chiseling & Chipping
DeWalt



- Use with spline drive

Item #	Type of Tool	Size (in.)
DTDW5772	Slotting Chisel	1 1/2 x 12
DTDW5770	Bull Point Chisel	12
DTDW5771	Bull Point Chisel	18
DTDW5779	Cold Chisel	1/2 x 12
DTDW5780	Cold Chisel	1/2 x 18
DTDW5780B15	Cold Chisel	1/2 x 18
DTDW5782	Bushing Tool	1 3/8 sq. x 12
DTDW5786B	Clay Spade	3/4 x 2 1/32
DTDW5783	Bushing Tool	3/4 x 2 1/32
DTDW5781	Asphalt Cutter	3/4 x 2 1/32

BLACK & DECKER
Spline Shank Hammer Bit

2 Cutter Head Design
DeWalt

- Large flute access for better dust extraction and longer life
- Double flute design gives quicker dust extraction and faster drilling
- Hardened core reduces breakage

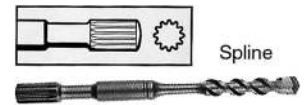

Item #	Dia. (in.)	Usable Length (in.)	Overall Length (in.)
DTDW5702	7/16	5	10
DTDW5708	9/16	5	10
DTDW5710	5/8	11	16
DTDW5713	1 1/16	5	10
DTDW5715	3/4	11	16
DTDW5716	3/4	17	22
DTDW5727	1 1/4	11	16
DTDW5731	1 1/2	11	16



BLACK & DECKER
Rotary Hammer Bits

SDS-Max™
DeWalt



2 Cutter Head Design:

- Large flute access for better dust extraction and longer life

4 Cutter Head Design:

- Four cutter heads reduce vibration for less user fatigue
- Concave heads design allows dust to enter flute chambers quickly, increasing bit life

Item #	Dia.	Usable Length (in.)	Overall Length (in.)
DTDW5804	1/2	16	21 1/2
DTDW5806	5/8	8	13 1/2
DTDW5812	3/4	16	21 1/2
DTDW5816	7/8	16	21 1/2
DTDW5818	1	8	13 1/2
DTDW5821	1 1/8	10	15
DTDW5822	1 1/8	18	21 1/2
DTDW5824	1 1/4	10	15
DTDW5825	1 1/4	18	21 1/2
DTDW5827	1 3/8	18	22 1/2
DTDW5828	1 1/2	18	22 1/2

BLACK & DECKER
Steel Bits 1-Piece

1-1/8" Hex
DeWalt



- Fully hardened steel body delivers increased life and durability
- Ring and notch retentions allow for use in electric and pneumatic hammers

Item #	Desc.
DTDW5960	0" Bull Point 1 1/8" Hex Shank
DTDW5962	0" Cold Chisel 1 1/8" Hex Shank
DTDW5961	3" Scaling Chisel 1 1/8" Hex Shank
DTDW5965	Clay Spade 1 1/8" Hex Shank
DTDW5963	Asphalt Cutter 1 1/8" Hex Shank
DTDW5964	Ground Rod Driver 1" Rod 1 1/8" Hex Shank
DTDW5966	6" x 6" Tamper Plate 1 1/8" Hex Shank
DTDW5967	Tamper Shank 1 1/8" Hex Shank

BLACK & DECKER
Carbide Core Bits
1-Piece
DeWalt



Item #	Dia. (in.)	Length (in.)
--------	------------	--------------

SDS Max Shank

DTDW5914	1 3/4	12
DTDW5915	1 3/4	22
DTDW5916	2	12
DTDW5917	2	22
DTDW5918	2 3/4	12
DTDW5919	2 3/4	22
DTDW5920	3 1/4	12
DTDW5921	3 1/4	22
DTDW5922	3 1/2	12
DTDW5923	3 1/2	22
DTDW5924	4	12
DTDW5925	4	22
DTDW5926	5	22
DTDW5927	6	22

Spline Shank

DTDW5930	1 3/4	12
DTDW5931	1 3/4	22
DTDW5932	2	12
DTDW5933	2	22
DTDW5934	2 3/4	12
DTDW5935	2 3/4	22
DTDW5936	3 1/4	12
DTDW5937	3 1/4	22
DTDW5938	3 1/2	12
DTDW5939	3 1/2	22
DTDW5940	4	12
DTDW5941	4	22
DTDW5942	5	22
DTDW5943	6	22

Replacement Centering Bit

DTDW5945



MILWAUKEE ELECTRIC TOOL CORP.

Reciprocating Blades

Super Sawzall®

- Super Sawzall® blades are made with Matrix II high speed steel teeth containing 8 percent cobalt to keep a sharper tooth edge longer
- Tough Bi-Metal design allows faster cutting, longer life blades that can bend without shattering
- Materials, tooth configuration and heat treating are designed to maximize performance in specific cutting applications
- Blades have a 1/2" universal tang that fits all Sawzall® and standard competitive saws

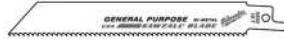

Item #	Recommended Use	T.P.I.	L x W x TH (in.)	Qty./Pack
MI48-00-5090	All purpose	10	4 x 3/4 x .035	5
MI48-00-5092	All purpose	10	6 x 3/4 x .035	5
MI48-00-5091	All purpose	8 1/2	6 x 3/4 x .050	5
MI48-00-5093	All purpose	8 1/2	8 x 3/4 x .050	5
MI48-00-5094	All purpose	8 1/2	12 x 3/4 x .050	5
MI48-00-5193	All purpose	10 1/4	8 x 5/8 x .035	5
MI48-00-5194	All purpose	10 1/4	12 x 5/8 x .035	5
MI48-00-5012	Wood w/nails	6	6" x 3/4" x .050	5
MI48-00-5031	Wood w/nails	5/8	6 x 3/4 x .050	5
MI48-00-5035	Wood w/nails	6	6 x 3/4 x .050	5
MI48-00-5036	Wood w/nails	6	9 x 3/4 x .050	5
MI48-00-5037	Wood w/nails	6	12 x 3/4 x .050	5
MI48-00-5041	Wood w/nails	4/6	6 x 1/2 x .050	5
MI48-01-6031	Wood w/nails	5/8	6 x 3/4 x .050	50
MI48-01-6035	Wood w/nails	6	6 x 3/4 x .050	50
MI48-01-6036	Wood w/nails	6	9 x 3/4 x .050	50
MI48-00-5162	Scroll cutting metal	14	3 5/8 x 5/16 x .035	5
MI48-00-5163	Scroll cutting metal	18	3 5/8 x 5/16 x .035	5
MI48-00-5015	Wood & Plastic	6	6 x 3/4 x .050	5
MI48-00-5016	Wood & Plastic	6	9 x 3/4 x .050	5
MI48-00-5017	Wood & Plastic	6	12 x 3/4 x .050	5
MI48-00-5184	Metal Cutting	18	6 x 3/4 x .035	5
MI48-00-5185	Metal Cutting	24	4 x 3/4 x .035	5
MI48-00-5186	Metal Cutting	24	6 x 3/4 x .035	5
MI48-00-5284	Metal Cutting	18	6 x 5/8 x .035	5
MI48-01-6185	Metal Cutting	24	4 x 3/4 x .035	50
MI48-01-6182	Metal Cutting	14	6 x 3/4 x .035	50
MI48-01-6184	Metal Cutting	18	6 x 3/4 x .035	50
MI48-01-6186	Metal Cutting	24	6 x 3/4 x .035	50
MI48-01-6188	Metal Cutting	18	9 x 3/4 x .035	50

MILWAUKEE ELECTRIC TOOL CORP.

Reciprocating Blades

Wood, Nail Embedded Wood and Demolition

Super Sawzall® AX™



- 1/2" Universal blade tang fits in all Sawzalls®
- Bi-metal construction increases blade life, blades do not shatter
- Matrix II teeth with 8% cobalt; blade reversible in clamp
- .062" thick for stiffer performance; sloped shape ideal for plunge cutting

Item #	T.P.I.	Length (in.)
MI48-00-1420	Grit	6
MI48-00-5181	12	4
MI48-00-5182	14	6
MI48-00-5183	18	4
MI48-00-5187	14	9
MI48-00-5188	18	9
MI48-00-5189	18	12
MI48-00-5282	14	6
MI48-00-5286	24	6

MILWAUKEE ELECTRIC TOOL CORP.

M12 Hackzall™ Blades

10-Pc. General Purpose Set



- Designed to maximize the cutting performance of the new M12 Hackzall™ reciprocating saw, these blades feature a thin kerf design that reduces the amount of drag and resistance while cutting, resulting in more cuts per battery charge
- M12 Hackzall™ Blade - 10 pc. general purpose set
- Includes: 2 wood blades, 3 EMT blades, 2 duct blades, 3 PVC blades, and storage pouch

Item #
MI49-22-0220

MILWAUKEE ELECTRIC TOOL CORP.

Reciprocating Blades

Sawzall® The Torch™

- Remodeling, rescue & demolition
- Width x Thickness: 1.0" x 0.42"



Item #	T.P.I.	Length (in.)	Qty. per Pack
MI48-00-5713	10	9	5
MI48-00-5782	14	6	5
MI48-00-5787	14	9	5
MI48-00-5784	18	6	5
MI48-00-8784	18	6	25
MI48-01-7784	18	6	100
MI48-00-8788	18	9	25
MI48-00-5789	18	12	5



MILWAUKEE ELECTRIC TOOL CORP.
Diamond Grit Blades

Sawzall® The Torch™

Diamond Grit The Torch Sawzall blades are ideal for cutting cast iron, hard tile, masonry and other abrasive and hard materials.



Features:

- Diamond Grit delivers up to 30x longer life than standard carbide grit blades; the result is a significantly lower cost per cut
- The precisely controlled size and placement of the diamond grit allow these blades to cut up to 2x faster than standard carbide grit blades
- A thicker, more rigid blade body resists fracturing and bending for maximum durability; the 1" tall blade body reduces blade twisting for straighter, more accurate cuts
- Package Quantity: 1 ea.

Item #	Blade Dim. (in.)	Shank (in.)	TPI/Grit	Body Material
MI48-00-1440	6x1x0.42	½ Universal	Diamond Coarse Grit	D6A Steel
MI48-00-1450	9x1x0.42	½ Universal	Diamond Coarse Grit	D6A Steel

MILWAUKEE ELECTRIC TOOL CORP.
Tungsten Carbide Blades

Heavy-Duty Sawzall®

- Custom ground teeth, set & hardened for maximum performance
- 1/2" universal tang for reciprocating saws
- Medium and coarse grits for cutting hardwood flooring, cast iron stainless steel, fiberglass materials (polyesters, epoxies, melamines), ceramic tile, stone, state, clay pipe, carbon, brick, plaster, marble and chalkboard



Item #	L x W x TH (in.)
MI48-00-1420	6 x ¾ x .032

MILWAUKEE ELECTRIC TOOL CORP.
Reciprocating Blades

All Purpose Demolition Sawzall® The Ax™

- For cutting wood, nail embedded wood, demolition work
- Excellent for plunge cutting into wood and nail embedded wood without bending blades
- 1/2" Universal Tang fits all Sawzall® saws
- TPI: 5/8; Width x Thickness: 1.0" x .062"



Item #	Length (in.)	Qty. per Pack
MI48-00-5021	6	5
MI48-01-7021	6	100
MI48-00-5026	9	5
MI48-00-8026	9	25
MI48-00-5027	12	5

MILWAUKEE ELECTRIC TOOL CORP.
Reciprocating Blades

All Purpose Demolition Sawzall® The Wrecker™

- For all woods, nail embedded wood, composition material, plastic, light gauge non-ferrous metals and aluminum
- Width x Thickness: 1.0" x .062"
- T.P.I.: 8



Item #	Length (in.)	Qty. per Pack
MI48-00-5701	6	5
MI48-00-5706	9	5
MI48-00-5711	12	5

MILWAUKEE ELECTRIC TOOL CORP.
Pruning Reciprocating Blades

Sawzall®

- Milwaukee® pruning blades deliver fast, clean cuts in limbs, branches and green wood
- Extra deep gullets easily remove chips for fast cutting
- Unique fleam ground teeth cut in both directions for clean cuts
- Induction hardened teeth for long life
- Shank: 1/2" Universal
- Packaging Size: 5



Item #	T.P.I.	L x W x TH (in.)
MI48-00-1301	5	9 x ¾ x 0.60
MI48-00-1303	5	12 x ¾ x .060



MILWAUKEE ELECTRIC TOOL CORP.
Reciprocating Blades
Sawzall® Ice Hardened™

- Ice Hardened blades are cryogenically treated to minimize soft metal (austenite) and create more hard metal (martensite)
- The result is a metal cutting blade that is more consistently hard throughout, for up to 50% longer life than standard blade
- A unique combination of relief angles forms a radius on the back of the tooth that reduces stress build-up during cutting and substantially extends blade life.
- Package Quantity: 5



Item #	T.P.I.	L x W x TH (in.)
MI48-00-4091	8/12	6 x 3/4 x .050
MI48-00-4093	8/12	8 x 3/4 x .050
MI48-00-4182	14	6 x 3/4 x .035
MI48-00-4184	18	6 x 3/4 x .035
MI48-00-4186	24	6 x 3/4 x .035
MI48-00-4187	14	9 x 3/4 x .035
MI48-00-4188	18	12 x 3/4 x .035

The Torch®

MI48-00-4712	10	6 x 1 x .042
MI48-00-4713	10	9 x 1 x .042
MI48-00-4782	14	6 x 1 x .042
MI48-00-4784	18	6 x 1 x .042
MI48-00-4787	14	9 x 1 x .042
MI48-00-4788	18	9 x 1 x .042

MILWAUKEE ELECTRIC TOOL CORP.
Plaster Reciprocating Blades
Sawzall®

- Milwaukee® plaster blades feature a "V" shape tooth to minimize tear out when cutting plaster and drywall
- Precision forming process creates sharper teeth for fast cutting
- Shank: 1/2" Universal
- Package Quantity: 5

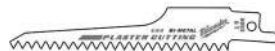

Item #	T.P.I.	L x W x TH (in.)
MI48-00-5052	6	5 x 3/4 x .050

MILWAUKEE ELECTRIC TOOL CORP.
Reciprocating Blades

14-Piece
Sawzall® Ice Hardened™



- Ice edge ultimate metal cutting Sawzall® blade kit
- 14-piece kit with roll up pouch
- Unique cryogenic heat treat process provides tougher teeth for extreme applications.
- Features Milwaukee's best selling 6" Super Sawzall® blades and our popular 9" torch blades

Item #

MI49-22-1131

MILWAUKEE ELECTRIC TOOL CORP.
Rough-In Sawzall® Blade

- Low Blade Profile cuts 2-1/8" diameter holes for 1-1/2" PVC pipe.
- 7-3/8" Length allows blade to cut holes through double top plates.
- Nail Guard™. Unique design protects against tooth fracture when cutting through holes in nail embedded wood.
- Fang Tip™. Fang Tip delivers fast plunge cutting through bottom plates and subfloors
- Blade Dimension: 7-3/8"x 1/2" x.062"
- Shank: 1/2" Universal
- TPI/Grit: 5 TPI
- Package Quantity: 5



Item #

MI48-00-1610

MILWAUKEE ELECTRIC TOOL CORP.
Flush Cut Sawzall® Blade

- Unique Blade Geometry protects against floor impacts during bottom plate cut-outs.
- Double Truss Design guides blade for straight window cut-outs.
- Fang Tip™ Fang Tip delivers fast plunge cutting for window cut-outs.
- Blade Dimension: 12" x 2-1/8" x .062"
- Shank: 1/2" Universal
- TPI/Grit: 5 TPI
- Package Quantity: 1



Item #

MI48-00-1600



MILWAUKEE ELECTRIC TOOL CORP.
Jig Saw Blades

U-Shank

- Milwaukee Jig Saw blades are designed and manufactured for the professional user
- Universal tang and fits Milwaukee Jig Saw model 6256-6 and other popular brands
- 5 blades per package



Item #	Recommended Use	T.P.I.	L x W (in.)
MI48-42-0801	Ceramics, tile	Grit	2 $\frac{3}{4}$ x $\frac{5}{16}$
MI48-42-2120	Metal cutting	18	2 $\frac{3}{4}$ x $\frac{9}{32}$
MI48-42-2160	Metal cutting	24	2 $\frac{3}{4}$ x $\frac{9}{32}$
MI48-42-2190	Metal cutting	14	3 $\frac{5}{8}$ x $\frac{9}{32}$
MI48-42-2300	General purpose	6	4 x $\frac{9}{32}$
MI48-42-2302	Wood cutting	6	4 x $\frac{9}{32}$
MI48-42-2310	General purpose	10	4 x $\frac{9}{32}$
MI48-42-2311	Wood cutting	10	4 x $\frac{9}{32}$
MI48-42-0850	Aluminum, Non-Ferrous Metals	8	4 x $\frac{9}{32}$
MI48-42-2192	Aluminum, Non-Ferrous Metals	14	5 x $\frac{9}{32}$
MI48-42-5300	Nail embedded wood	6	4 x $\frac{9}{32}$

MILWAUKEE ELECTRIC TOOL CORP.
Jig Saw Blades

T-Shank

- Bi-metal blades last longer than high speed steel or carbon blades
- Detail to the material used, tooth shape and sharpness make these blades cut clean, fast and have a longer life
- These blades use T-Shank and fit Milwaukee Jig Saws and other popular brands
- 5 blades per package



Item #	Recommended Use	T.P.I.	L x W (in.)
MI48-42-5190	Thick metal over $\frac{1}{4}$ " thick	14	3 x $\frac{9}{32}$
MI48-42-5121	Metal over $\frac{1}{8}$ " thick	18	3 x $\frac{9}{32}$
MI48-42-5161	Metal under $\frac{1}{8}$ " thick	24	3 x $\frac{9}{32}$
MI48-42-5192	Thick metal, tubing, etc.	14	5 $\frac{1}{4}$ x $\frac{9}{32}$
MI48-42-5166	Thin metal under $\frac{1}{8}$ " thick	24	5 $\frac{1}{4}$ x $\frac{9}{32}$
MI48-42-5311	Wood, fast & clean cuts	10	4 x $\frac{9}{32}$
MI48-42-5310	Fast cutting, nail embedded wood	10	4 x $\frac{9}{32}$
MI48-42-5540	Reverse tooth, no top splinters	10	4 x $\frac{9}{32}$
MI48-42-5850	Aluminum, non-ferrous metals	8	4 x $\frac{9}{32}$



BOSCH TOOLS
Jig Saw Blade



- Designed for the professional user
- Straight, clean cuts

Item #	Recommended Use	T.P.I.	Working Length (in.)
BOHPT101D	Clean For Wood	5-6 Progressive	3
BOT101A	Special For Plexiglass	14	2 $\frac{3}{4}$
BOT101A0	Clean For Wood	20	2 $\frac{5}{16}$
BOT101B	Clean For Wood	10 variable gullet	3
BOT101BF	Clean For Hardwood	10 variable gullet	3
BOT101BR	Clean For Wood	10	3
BOT101DP	Clean For Hardwood	6	2 $\frac{3}{4}$
BOT111G	Basic For Metal	36	2 $\frac{5}{8}$
BOT111C	Basic For Wood	8	3
BOT111CF	Accurate For Wood With Nails	8	3
BOT113A3	Special For Soft-material	Knife edge	3
BOT118A	Basic For Metal	17-24 progressive	2 $\frac{5}{8}$
BOT118AF	Flexible For Metal	17-24 progressive	2 $\frac{5}{8}$
BOT118B	Basic For Metal	11-14 progressive	2 $\frac{5}{8}$
BOT118EF	Flexible For Metal	14-18 progressive	2 $\frac{5}{8}$
BOT118G	Basic For Metal	36	2
BOT119BO	Basic For Wood	12	2
BOT119BO3	Basic For Wood	12	2 $\frac{3}{16}$
BOT123X	Progressor For Metal	10-24 progressive	3
BOT127D	Special For Aluminum	8	3
BOT127DF	Flexible For Aluminum	8	3 $\frac{5}{8}$
BOT18A	Basic For Metal	24	1 $\frac{1}{8}$
BOT211HF	Basic For Wood	10	2
BOT218A	Basic For Metal	24	2
BOT318A	Basic For Metal	24	4
BOT318B	Basic For Metal	14	4.24



M K MORSE
Hole Saws
Bi-Metal
Master Cobalt®



- Features an M3 high-speed steel cutting edge, electron beam welded to a tough steel backer
- Positive rake tooth design provides better chip clearance as teeth cut into wood, plastic or any machinable metal
- Bi-metal design bonds M3 cutting edge to fatigue resistant backer

Item #	Diameter (in.)	Pipe Tap Size (in.)	Pipe Ent. Size (in.)
MKAV09	9/16	-	-
MKAV10	5/8	-	-
MKAV11	11/16	-	-
MKAV12	3/4	1/2	3/8
MKAV13	13/16	-	-
MKAV14	7/8	3/4	1/2
MKAV15	15/16	-	-
MKAV16	1	-	-
MKAV17	1 1/16	-	-
MKAV18	1 1/8	1	3/4
MKAV19	1 3/16	-	-
MKAV20	1 1/4	-	-
MKAV21	1 5/16	-	-
MKAV22	1 3/8	-	1
MKAV23	1 7/16	-	-
MKAV24	1 1/2	1 1/4	-
MKAV25	1 9/16	-	-
MKAV26	1 5/8	-	-
MKAV27	1 11/16	-	-
MKAV28	1 3/4	1 1/2	1 1/4
MKAV29	1 13/16	-	-
MKAV30	1 7/8	-	-
MKAV32	2	-	1 1/2
MKAV33	2 1/16	-	-
MKAV34	2 1/8	-	-
MKAV36	2 1/4	2	-
MKAV37	2 5/16	2	-
MKAV38	2 3/8	-	-
MKAV40	2 1/2	-	2
MKAV41	2 9/16	-	-
MKAV42	2 5/8	2 1/2	-
MKAV44	2 3/4	-	-
MKAV46	2 7/8	-	-
MKAV48	3	-	2 1/2
MKAV50	3 1/8	-	-
MKAV52	3 1/4	3	-

Item #	Diameter (in.)	Pipe Tap Size (in.)	Pipe Ent. Size (in.)
MKAV54	3 3/8	-	-
MKAV56	3 1/2	-	-
MKAV58	3 5/8	-	3
MKAV60	3 3/4	3 1/2	-
MKAV62	3 7/8	3 1/2	-
MKAV64	4	-	-
MKAV66	4 1/8	-	3 1/2
MKAV68	4 1/4	4	-
MKAV70	4 3/8	4	-
MKAV72	4 1/2	4 1/2	4
MKAV76	4 3/4	-	-
MKAV80	5	-	-
MKAV88	5 1/2	-	-
MKAV92	5 3/4	-	-
MKAV96	6	-	-

M K MORSE
Hole Saw
Tungsten Carbide Tipped

- Specifically designed for sawing holes in abrasive materials such as fiberglass, particleboard, asbestos board, and formica
- Tungsten carbide tooth tips offer the highest wear resistance possible and longer life cutting abrasive materials
- Ground and set teeth to help cut materials that bi-metal saws will not cut
- 3 teeth per inch creates wider gullet for better chip clearance and faster cutting



Item #	Diameter (in.)
MKAT12	3/4
MKAT14	7/8
MKAT16	1
MKAT18	1 1/8
MKAT20	1 1/4
MKAT22	1 3/8
MKAT24	1 1/2
MKAT26	1 5/8
MKAT32	2
MKAT36	2 1/4
MKAT38	2 3/8
MKAT40	2 1/2
MKAT44	2 3/4
MKAT48	3
MKAT56	3 1/2
MKAT58	3 5/8
MKAT64	4
MKAT68	4 1/4
MKAT72	4 1/2
MKAT80	5
MKAT88	5 1/2
MKAT96	6



M K MORSE Hole Saw



Tungsten Carbide Grit

- The long-lasting choice for cutting holes in materials too hard or abrasive for standard bi-metal saws, or so thin they would strip bi-metal or chip carbide teeth
- Ideal for cutting ceramics, fiberglass, hardwoods, cast iron, composites, etc.
- Super resistance to heat, wear and abrasion with shock resistant back
- Tungsten carbide grains are bonded to alloy backs with a gulleted, snag resistant edge
- 1-1/2" cutting depth

Item #	Diameter (in.)	Pipe Tap Size (in.)	Pipe Ent. Size (in.)
MKATCG12	3/4	1/2	3/8
MKATCG14	7/8	3/4	1/2
MKATCG16	1	-	-
MKATCG18	1 1/8	1	3/4
MKATCG19	1 3/16	-	-
MKATCG20	1 1/4	-	-
MKATCG22	1 3/8	-	1
MKATCG24	1 1/2	1 1/4	-
MKATCG26	1 5/8	-	-
MKATCG28	1 3/4	1 1/2	1 1/4
MKATCG32	2	-	1 1/2
MKATCG36	2 1/4	2	-
MKATCG38	2 3/8	-	2
MKATCG40	2 1/2	-	-
MKATCG44	2 3/4	-	-
MKATCG48	3	-	2 1/2
MKATCG56	3 1/2	-	-
MKATCG58	3 5/8	-	3
MKATCG64	4	-	-
MKATCG72	4 1/2	-	4
MKATCG80	5	-	-
MKATCG88	5/2	-	-
MKATCG96	6	-	-

M K MORSE Carbon Steel Arbors

With Pilot Drills

- Come complete with pilot drills
- Adapt Morse Hole Saws to any power drill



Item #	Shank Size	Drill Number	Chuck Size	Fits Saws (in.)
MKM24K	1/4 Round	MPD401	1/4	*9/16 - 1 3/16
MKM34	3/8 Hex	MPD4S01	3/8	*9/16 - 1 3/16
MKM44	7/16 Hex	MPD401	1/2	*9/16 - 1 3/16
MKM35PS	3/8 Hex	MPD4S01	3/8	1 1/4 - 6
MKM45P	7/16 Hex	MPD401	1/2	1 1/4 - 6
MKM45	7/16 Hex	MPD401	1/2	1 1/4" - 2 3/8"

M K MORSE Master Electricians Hole Saw Kit

Bi-Metal Variable Pitch Master Cobalt®



- Entrance sizes to 4"
- Saws (1 each): 7/8", 1-1/8", 1-3/8", 1-3/4", 2", 2-1/2", 3", 3-5/8", 4-1/8", 4-1/2"
- Arbors (1 each): M24K, M44, M45P

Item #
MKAV08E

M K MORSE Electricians Hole Saw Kit

Bi-Metal Variable Pitch Master Cobalt®



- Entrance sizes to 2"
- Saws (1 each): 7/8", 1-1/8", 1-3/8", 1-3/4", 2", 2-1/2"
- Arbors (1 each): M44, M45P

Item #
MKAV02E

M K MORSE Hole Saw Kit

Bi-Metal/Plumber Master Cobalt®



- Contains pipe tap sizes for pipe through 2"
- Saws (1 each): 3/4", 7/8", 1-1/8", 1-1/2", 1-3/4", 2-1/4"
- Arbors (1 each): M44, M45P

Item #
MKAV04P



M K MORSE
Hole Saws

Bi-Metal
Advanced Edge



* Metric sizes shown with asterisk are exact millimeter sizes. All other metric sizes are approximate metric equivalents of exact inch sizes.

Item #	Dia. (in.)	Dia. (mm)	Pipe Tap Size (in.)	Pipe Ent. Size (in.)
--------	------------	-----------	---------------------	----------------------

MK09-MK244 use the following 1/2-20 arbors MK04 or MK05

Item #	Dia. (in.)	Dia. (mm)	Pipe Tap Size (in.)	Pipe Ent. Size (in.)
MKMK09	9/16	14		
MKMK10	5/8	16		
MKMK105		16*		
MKMK11	11/16	17		
MKMK12	3/4	19	1/2	3/8
MKMK125		20*		
MKMK13	13/16	21		
MKMK14	7/8	22	3/4	1/2
MKMK15	15/16	24		
MKMK155		25*		
MKMK16	1	25		
MKMK17	1 1/16	27		
MKMK18	1 1/8	29	1	3/4
MKMK185		30*		
MKMK19	1 3/16	30		
MKMK20	1 1/4	32		
MKMK204	1 1/4	32		
MKMK205		32*		
MKMK21	1 5/16	33		
MKMK22	1 3/8	35		1
MKMK224	1 3/8	35		
MKMK225		35*		
MKMK23	1 7/16	37		
MKMK24	1 1/2	38	1 1/4	
MKMK244	1 1/2	38	1 1/4	

MK20-MK385 use the following 5/8-18 arbors MK03, MK06

Item #	Dia. (in.)	Dia. (mm)	Pipe Tap Size (in.)	Pipe Ent. Size (in.)
MKMK25	1 1/16	40		
MKMK255		40*		
MKMK26	1 5/8	41		
MKMK27	1 11/16	43		
MKMK28	1 3/4	44	1 1/2	1 1/4
MKMK285		45*		
MKMK29	1 3/16	46		
MKMK30	1 7/8	48		

Item #	Dia. (in.)	Dia. (mm)	Pipe Tap Size (in.)	Pipe Ent. Size (in.)
--------	------------	-----------	---------------------	----------------------

MKMK315		50*		
MKMK32	2	51		1 1/2

MK20-MK38 use the following 5/8-18 arbors MK03, MK06

MKMK33	2 1/16	52		
MKMK34	2 1/8	54		
MKMK345		55*		
MKMK36	2 1/4	57	2	
MKMK37	2 5/16	59		
MKMK38	2 3/8	60		
MKMK385		62		

MK40-MK96 use the following 5/8-18 arbors MK03, MK06

MKMK40	2 1/2	64		2
MKMK41	2 9/16	65		
MKMK42	2 5/8	67	2 1/2	
MKMK425		68*		
MKMK435	2 11/16	68.5*		
MKMK44	2 3/4	70		
MKMK46	2 7/8	73		
MKMK475		75*		
MKMK48	3	76		2 1/2
MKMK50	3 1/8	79		
MKMK52	3 1/4	83	3	
MKMK54	3 3/8	86		
MKMK56	3 1/2	89		
MKMK58	3 5/8	92		3
MKMK60	3 3/4	95	3 1/2	
MKMK62	3 7/8	98		
MKMK63		100*		
MKMK64	4	102		
MKMK66	4 1/8	105		3 1/2
MKMK68	4 1/4	108	4	
MKMK70	4 3/8	111		
MKMK72	4 1/2	114		4
MKMK76	4 3/4	121	4 1/2	
MKMK80	5	127		
MKMK84	5 1/4	133		
MKMK88	5 1/2	140		
MKMK92	5 3/4	146		
MKMK96	6	152		



M K MORSE Hole Saw Kits

Advanced Edge



- More teeth , deeper gullet in the cutting action increases material removal
- New tooth form maximizes penetration with a positive rake face
- Electricians Kit 8 piece, 6 AE Hole Saws (7/8", 1-1/8", 1-3/8", 1-3/4", 2", 2-1/2"), 2 arbors
- Plumbers Kit 8 Piece, 6 AE Hole Saws (3/4", 7/8", 1-1/8", 1-1/2", 1-3/4", 2-1/4"), 2 Arbors
- General Purpose Kit 11 Piece, 9 AE Hole Saws (3/4", 7/8", 1-1/8", 1-3/8", 1-1/2", 1-3/4", 2", 2-1/4", 2-1/2"), 2 Arbors
- Master Electricians Kit 14 Piece, 11 AE Hole Saws (3/4", 7/8", 1-1/8", 1-3/8", 1-3/4", 2", 2-1/2", 3", 3-5/8", 4-1/8", 4-3/4"), 3 Arbors

Item #	Desc.
MKMK0600L	Electricians Kit 8-Piece
MKMK8600P	Plumbers Kit 8-Piece
MKMK7700G	General Purpose Kit 11-Piece
MKMK21200L	Master Electricians Kit 14-Piece

M K MORSE Arbors

Advanced Edge



Item #	Desc.	Use with Diameters:
MKMK03	1/2" & Larger Hex	Over 1 1/4"
MKMK04	1/4" & Larger Hex	Up To 1 3/16"
MKMK05	3/8" & Larger Hex	Up To 1 3/16"
MKMK06	3/8" & Larger Hex	Over 1 1/4"

M K MORSE Pilot Drills

Advanced Edge



Item #	Desc.
MKMK5156PD	3 1/16" x 1/4" (78 mm x 6.5 mm)

M K MORSE Pilot Drills and Accessories

- ME12 Arbor Extension can be used with all 7/16" shank arbors

Item #	Comp #	Desc.
MKMPD4N01	140782	4 in. x 1/4 in. Pilot Drill, 3 Notches for Set Screws
MKME12	141123	12 in. Extension for Shank of 7/16 in. (10.5 mm) Arbors
MKMPD4CT01	NA	4 in. X 1/4 in. Carbide Tipped Pilot Drill



BLACK & DECKER 7-1/4" Circular Saw Blade

16T Carbide Thin Kerf DeWalt



- Tougher tungsten carbide stays sharper longer; thin kerf for smoother cut
- Ribbed heat vents allow blade to run cooler, reducing blade flexing and binding; all blades feature 5/8" arbor with diamond knock-out
- Diameter: 7-1/4"; Arbor size: 5/8 rd; Teeth: 24

Item #
DTDW3578

BLACK & DECKER 7-1/4" Circular Saw Blade

24 T Carbide

- Economy Carbide Blade; Universal arbor



Item #
DTB7254524

BLACK & DECKER 12" Saw Blades

Metal Cutting DeWalt



- This blade has been designed to work with the DW872 Multi-Cutter™ system
- For use with metal cutting "dry cut" miter saws only
- Specially formulated carbide with 12% titanium for long life in metal cutting; expansion slots dissipate heat to extend blade life
- Modified ATB tooth geometry provides clean, burr-free cuts
- Dia.: 12"; Arbor: 1"; Kerf: 0.087; Max. RPM: 1800

Item #	Desc.	Teeth
DTDW7737	Heavy Gauge Ferrous Metal Cutting	60
DTDW7745	Lt. Ga. Steel	90
DTDW7739	Stainless Steel Cutting	80
DTDW7749	Stainless Steel	90

BLACK & DECKER 14" Diamond Chop Saw Blade

- Diamond Edge provides 100x the life vs standard DeWalt chop saw wheel
- Advanced Brazing Technology cuts metal with the speed of a conventional abrasive blade
- Exposed Diamond Matrix allows the blade to cut concrete, plastic, fiberglass, rubber, non-ferrous metals and other soft materials without loading



Item #
DTDW8500

IRWIN Industrial Tools

IRWIN INDUSTRIAL TOOLS 6-1/2" Circular Saw Blade Marathon®



- The Fastest Framing Blade Ever!™
- Every other tooth is thinner for faster cuts
- New heat vent/expansion slot design reduces vibration for longer life and straighter cuts
- Diameter: 6-1/2"
- Tooth Count: 20
- Arbor: 5/8" Diamond

Item #
IR24021

IRWIN INDUSTRIAL TOOLS 7-1/4" Circular Saw Blade Thin Kerf Marathon®



- Diameter: 7-1/4 in./184 mm
- No of Teeth: 24
- Arbor Hole: Universal
- Kerf: .067 in. / 1.7 mm

Item #
IR24030

MORSE THE M. K. MORSE COMPANY

M K MORSE Band Saw Blades



Item #	TPI	Lgth. (in.)	Width (in.)	Thick.. (in.)	Tooth Set
MKZWEP5318WS	18	35 3/8	1/2	0.020	Wavy
MKZWEPXTL441014	10-14	44 7/8	1/2	0.020	Modified Raker
MKZWEPXTL441418	14-18	44 7/8	1/2	0.020	Wavy
MKZWEPXTL442024	20-24	44 7/8	1/2	0.020	Wavy

Milwaukee

MILWAUKEE ELECTRIC TOOL CORP. Self-feed Bits

Milwaukee®



- Self-feed bits cut faster, have improved balance with reduced runout
- Shanks have flat surfaces for secure chuck grip
- Large self-feed bits in 3", 3-5/8" and 4-5/8" sizes have double inside cutter blades that shave hole radius for clean, smooth holes without pressure

Item #	Desc. Diameter (in.)	For Std Pipe Sizes (in.)
MI48-25-3621	3 5/8	3*
MI48-25-4125	4 1/8	3*
MI48-25-4621	4 5/8	4*

MILWAUKEE ELECTRIC TOOL CORP. Heavy-Duty Self-feed Bits



Item #	Diameter (in.)
MI48-25-1001	1
MI48-25-1121	1 1/8
MI48-25-1251	1 1/4
MI48-25-1371	1 3/8
MI48-25-1501	1 1/2
MI48-25-1751	1 3/4
MI48-25-2001	2
MI48-25-2121	2 1/8
MI48-25-2251	2 1/4
MI48-25-2561	2 9/16
MI48-25-3001	3

MILWAUKEE ELECTRIC TOOL CORP. 4-Bit Contractor's Kit

Self-feed Bits

- Assortment of Milwaukee self-feed bits for big hole drilling
- Sizes include 1-3/8", 1-1/2", 2-1/8", 2-9/16" diameters
- Also 5-1/2" one piece - shank and coupling - extension and carrying case



Item #
MI49-22-0135



MILWAUKEE ELECTRIC TOOL CORP.
7-Bit Contractor Kits

Self-feed Bits

- Complete assortment of the most commonly used Milwaukee self-feed bits for big hole drilling
- Sizes include 1", 1-1/8", 1-1/4", 1-1/2", 1-3/4", 2-1/8", 2-9/16" diameters
- Also 5-1/2" one piece - shank and coupling - extension and carrying case



Item #
MI49-22-0130

MILWAUKEE ELECTRIC TOOL CORP.
7-Bit Plumber's Kits

Hole Saw Bits

- Complete assortment of the most commonly used Milwaukee bits for big hole drilling
- Quick change auger sizes include 7/8" (48-13-6552), 1-1/8" (48-13-6554), 1-1/4" (48-13-6555), 1-1/2" (48-13-6557) auger bits and self-feed bits in 1-3/4", 2-1/8", 2-9/16" diameters
- Also 5-1/2" one piece - shank and coupling - extension and carrying case



Item #
MI49-22-0065

MILWAUKEE ELECTRIC TOOL CORP.
Universal Shank Extensions

QUICK-LOK™

- 7/16" Universal QUICK-LOK™ Extension has an innovative design that fits all 7/16" shanks - with or without a power-groove
- Unique design requires no tools to change out bits, making it fast and efficient
- Impact rated for maximum durability
- Exclusive QUICK-LOK™ accepts all 7/16" shanks



Item #	Length (in.)
MI48-28-1030	5½
MI48-28-1040	12
MI48-28-1050	18
MI48-28-1060	24



TRIUMPH TWIST DRILL CO.
Jobber Length Drills

HSS T1HD Series
Thunderbit®



- 135° split-point for quick penetration and reduced "walking"
- Premium-grade industrial steel for longer life and heat resistance
- Unique flute design for superior material removal
- Finish: Black/Bronze oxide
- Range of applications: Iron, steel, stainless steel, wood
- Open flute design for easier chip evacuation
- Made In USA

Item #	Size	Decimal Equivalent	Flute Length	Overall Length	Env. Qty.
TR12504	1/16	.0625	7/8	17/8	12
TR12505	5/64	.0781	1	2	12
TR12506	3/32	.0938	1¼	2¼	12
TR12508	1/8	.1250	1½	2¾	12
TR12509	9/64	.1406	1¾	27/8	12
TR12510	5/32	.1562	2	3½	12
TR12511	11/64	.1719	2½	3¼	12
TR12512	3/16	.1875	25/16	3½	12
TR12513	13/64	.2031	27/16	35/8	12
TR12514	7/32	.2188	2½	3¾	12
TR12515	15/64	.2344	25/8	37/8	12
TR12516	1/4	.2500	2¾	4	12
TR12517	17/64	.2656	27/8	41/8	12
TR12518	9/32	.2812	215/16	4¼	12
TR12519	19/64	.2969	31/16	43/8	12
TR12520	5/16	.3125	33/16	4½	6
TR12521	21/64	.3281	35/16	45/8	6
TR12522	11/32	.3438	37/16	4¾	6
TR12523	23/64	.3594	3½	47/8	6
TR12524	3/8	.3750	35/8	5	6
TR12525	25/64	.3906	3¾	51/8	6
TR12526	13/32	.4062	37/8	5¼	6
TR12527	27/64	.4219	315/16	53/8	6
TR12528	7/16	.4375	41/16	5½	6
TR12529	29/64	.4531	43/16	55/8	6
TR12530	15/32	.4688	45/16	5¾	6
TR12531	31/64	.4844	43/8	57/8	6
TR12532	1/2	.5000	4½	6	6



TRIUMPH TWIST DRILL CO.
Jobber Length Drills



Cobalt T1C Series

- 135° split-point for quick penetration and reduced "walking"
- M-35 cobalt steel for increased heat resistance and longer life
- Designed for difficult-to-drill alloy applications
- Finish: Bronze oxide
- Range of applications: Steel, stainless steel
- Made In USA

Item #	Size	Decimal Equivalent	Flute Length	Overall Length	Env. Qty.
TR11504	1/16	.0625	7/8	1 7/8	12
TR11505	5/64	.0781	1	2	12
TR11506	3/32	.0938	1 1/4	2 1/4	12
TR11507	7/64	.1094	1 1/2	2 5/8	12
TR11508	1/8	.1250	1 5/8	2 3/4	12
TR11509	9/64	.1406	1 3/4	2 7/8	12
TR11510	5/32	.1562	2	3 1/8	12
TR11511	11/64	.1719	2 1/8	3 1/4	12
TR11512	3/16	.1875	2 5/16	3 1/2	12
TR11513	13/64	.2031	2 7/16	3 5/8	12
TR11514	7/32	.2188	2 1/2	3 3/4	12
TR11515	15/64	.2344	2 5/8	3 7/8	12
TR11516	1/4	.2500	2 3/4	4	12
TR11517	17/64	.2656	2 7/8	4 1/8	12
TR11518	9/32	.2812	2 15/16	4 1/4	12
TR11519	19/64	.2969	3 1/16	4 3/8	12
TR11520	5/16	.3125	3 3/16	4 1/2	6
TR11521	21/64	.3281	3 5/16	4 5/8	6
TR11522	11/32	.3438	3 7/16	4 3/4	6
TR11523	23/64	.3594	3 1/2	4 7/8	6
TR11524	3/8	.3750	3 5/8	5	6
TR11525	25/64	.3906	3 3/4	5 1/8	6
TR11526	13/32	.4062	3 7/8	5 1/4	6
TR11527	27/64	.4219	3 15/16	5 3/8	6
TR11528	7/16	.4375	4 1/16	5 1/2	6
TR11529	29/64	.4531	4 3/16	5 5/8	6
TR11530	15/32	.4688	4 5/16	5 3/4	6
TR11531	31/64	.4844	4 3/8	5 7/8	6
TR11532	1/2	.5000	4 1/2	6	6

TRIUMPH TWIST DRILL CO.
Screw Machine Length Drills

HSS T4 Series



- 135° split-point for quick penetration and reduced "walking"
- Black oxide finish for added lubricity
- Short length and heavy-duty construction provides additional strength
- Range of applications: Iron, steel, stainless steel, wood
- Made In USA

Item #	Size	Decimal Equivalent	Flute Length	Overall Length	Env. Qty.
TR44404	1/16	.0625	5/8	1 5/8	12
TR44405	5/64	.0781	11/16	1 11/16	12
TR44406	3/32	.0938	3/4	1 3/4	12
TR44407	7/64	.1094	13/16	1 13/16	12
TR44408	1/8	.1250	7/8	1 7/8	12
TR44409	9/64	.1406	15/16	1 15/16	12
TR44410	5/32	.1562	1	2 1/16	12
TR44412	3/16	.1875	1 1/8	2 3/16	12
TR44414	7/32	.2188	1 1/4	2 3/8	12
TR44415	15/64	.2344	1 5/16	2 7/16	12
TR44416	1/4	.2500	1 3/8	2 1/2	12
TR44417	17/64	.2656	1 7/16	2 5/8	12
TR44418	9/32	.2812	1 1/2	2 11/16	12
TR44419	19/64	.2969	1 9/16	2 3/4	12
TR44420	5/16	.3125	1 5/8	2 13/16	6
TR44421	21/64	.3281	1 11/16	2 15/16	6
TR44424	3/8	.3750	1 9/16	3 1/8	6
TR44425	25/64	.3906	1 7/8	3 1/4	6
TR44426	13/32	.4062	1 15/16	3 5/16	6
TR44427	27/64	.4219	2	3 3/8	6
TR44428	7/16	.4375	2 1/16	3 7/16	6
TR44429	29/64	.4531	2 1/8	3 9/16	6
TR44432	1/2	.5000	2 1/4	3 3/4	6



TRIUMPH TWIST DRILL CO.

Aircraft Drills



HSS T6HH & T12HH Series

- 135° split-point for quick penetration and reduced "walking"
- Black oxide finish for added lubricity
- Range of applications: Iron, steel, stainless steel, wood
- For hard-to-reach drilling
- Made In USA

Item #	Size	Decimal Equivalent	Flute Length	Overall Length	Env. Qty.
--------	------	--------------------	--------------	----------------	-----------

T6HH

TR57505	5/64	.0781	1	6	6
TR57506	3/32	.0938	1¼	6	6
TR57507	7/64	.1094	1½	6	6
TR57508	1/8	.1250	1⅝	6	6
TR57509	9/64	.1406	1¾	6	6
TR57510	5/32	.1562	2	6	6
TR57511	11/64	.1719	2⅛	6	6
TR57512	3/16	.1875	2¼	6	6
TR57514	7/32	.2188	2½	6	6
TR57515	15/64	.2344	2⅝	6	6
TR57516	¼	.2500	2¾	6	6
TR57520	5/16	.3125	3⅜	6	6
TR57524	3/8	.3750	3⅝	6	6
TR57528	7/16	.4375	4¼	6	6
TR57532	½	.5000	4½	6	6

T12HH

TR58508	1/8	.1250	1⅝	12	6
TR58512	3/16	.1875	2⅝	12	6
TR58516	¼	.2500	2¾	12	6
TR58520	5/16	.3125	3⅜	12	3
TR58524	3/8	.3750	3⅝	12	3
TR58528	7/16	.4375	4¼	12	3
TR58532	½	.5000	4½	12	3

TRIUMPH TWIST DRILL CO.

Reduced Shank Drill

HSS T9F Series



- 1/2" Shank
- 118° Point, high-speed steel, black oxide flutes - 3 flats
- Not designed to enlarge existing holes
- Flatted shank prevents slippage in three jaw chuck
- Flute Length - 3"
- Overall Length - 6"
- Made In USA

Item #	Size	Decimal Equivalent
--------	------	--------------------

TR92833	33/64	.5156
TR92834	17/32	.5312
TR92835	35/64	.5469
TR92836	9/16	.5625
TR92837	37/64	.5781
TR92838	19/32	.5938
TR92840	5/8	.6250
TR92841	41/64	.6406
TR92842	21/32	.6562
TR92844	11/16	.6875
TR92845	45/64	.7031
TR92846	23/32	.7188
TR92847	47/64	.7344
TR92848	3/4	.7500
TR92849	49/64	.7656
TR92850	25/32	.7812
TR92852	13/16	.8125
TR92853	53/64	.8281
TR92854	27/32	.8438
TR92856	7/8	.8750
TR92860	15/16	.9375
TR92863	63/64	.9844
TR92864	1	1.0000
TR92868	11/16	1.0625
TR92872	11/8	1.1250
TR92876	13/16	1.1875
TR92880	1¼	1.2500
TR92884	15/16	1.3125
TR92888	1⅝	1.3750
TR92896	1½	1.5000



TRIUMPH TWIST DRILL CO.
Double End Body Drills

HSS TSM8 Series

- 135° split-point for quick penetration and reduced "walking"
- Popular for pop rivet drilling applications
- Use for drilling any thin sheet material
- Finish: Black oxide
- Flute Length: 1/2
- Made In USA



Item #	Size	Decimal Equivalent	Overall Length
TR98808	1/8	.1250	2
TR98809	9/64	.1406	2
TR98810	5/32	.1562	2 1/16
TR98812	3/16	.1875	2 3/16
TR98814	7/32	.2188	2 3/8
TR98816	1/4	.2500	2 1/2
TR98820	20	.1610	2 1/8
TR98830	30	.1285	2

TRIUMPH TWIST DRILL CO.
Jobber Length Drills

T1D Series

- 135° Split-Point for quick penetration and reduced "walking"
- High speed steel
- Black oxide finish
- Use for heavy-duty construction
- Heavy-duty geometry and construction
- Made In USA



Item #	Size	Decimal Equivalent	Flute Length	Overall Length	Env. Qty.
TR11404	1/16	.0625	7/8	1 7/8	12
TR11405	5/64	.0781	1	2	12
TR11406	3/32	.0938	1 1/4	2 1/4	12
TR11407	7/64	.1094	1 1/2	2 5/8	12
TR11408	1/8	.1250	1 5/8	2 3/4	12
TR11409	9/64	.1406	1 3/4	2 7/8	12
TR11410	5/32	.1562	2	3 1/8	12
TR11411	11/64	.1719	2 1/8	3 1/4	12
TR11412	3/16	.1875	2 5/16	3 1/2	12
TR11413	13/64	.2031	2 7/16	3 5/8	12
TR11414	7/32	.2188	2 1/2	3 3/4	12
TR11415	15/64	.2344	2 5/8	3 7/8	12

Item #	Size	Decimal Equivalent	Flute Length	Overall Length	Env. Qty.
TR11416	1/4	.2500	2 3/4	4	12
TR11417	17/64	.2656	2 7/8	4 1/8	12
TR11418	9/32	.2812	2 15/16	4 1/4	12
TR11419	19/64	.2969	3 1/16	4 3/8	12
TR11420	5/16	.3125	3 3/16	4 1/2	6
TR11421	21/64	.3281	3 5/16	4 5/8	6
TR11422	11/32	.3438	3 7/16	4 3/4	6
TR11423	23/64	.3594	3 1/2	4 7/8	6
TR11424	3/8	.3750	3 5/8	5	6
TR11425	25/64	.3906	3 3/4	5 1/8	6
TR11426	13/32	.4062	3 7/8	5 1/4	6
TR11427	27/64	.4219	3 15/16	5 3/8	6
TR11428	7/16	.4375	4 1/16	5 1/2	6
TR11428	29/64	.4531	4 3/16	5 5/8	6
TR11430	15/32	.4688	4 5/16	5 3/4	6
TR11431	31/64	.4844	4 3/8	5 7/8	6
TR11432	1/2	.5000	4 1/2	6	6

Don't see the sizes you need?

Call your Edge sales representative for help today!



TRIUMPH TWIST DRILL CO.
Jobber Length Drills

T2B Series



- 118° Point
- High speed steel
- Black oxide finish
- General purpose use
- Made In USA

Item #	Size	Decimal Equivalent	Flute Length	Overall Length	Env. Qty.
TR12201	#1	.2280	2 ⁵ / ₈	3 ⁷ / ₈	12
TR12202	#2	.2210	2 ⁵ / ₈	3 ⁷ / ₈	12
TR12203	#3	.2130	2 ¹ / ₂	3 ³ / ₄	12
TR12204	#4	.2090	2 ¹ / ₂	3 ³ / ₄	12
TR12205	#5	.2055	2 ¹ / ₂	3 ³ / ₄	12
TR12206	#6	.2040	2 ¹ / ₂	3 ³ / ₄	12
TR12207	#7	.2010	2 ⁷ / ₁₆	3 ⁵ / ₈	12
TR12208	#8	.1990	2 ⁷ / ₁₆	3 ⁵ / ₈	12
TR12209	#9	.1960	2 ⁷ / ₁₆	3 ⁵ / ₈	12
TR12210	#10	.1935	2 ⁷ / ₁₆	3 ⁵ / ₈	12
TR12211	#11	.1910	2 ⁵ / ₁₆	3 ¹ / ₂	12
TR12212	#12	.1890	2 ⁵ / ₁₆	3 ¹ / ₂	12
TR12213	#13	.1850	2 ⁵ / ₁₆	3 ¹ / ₂	12
TR12214	#14	.1820	2 ³ / ₁₆	3 ³ / ₈	12
TR12215	#15	.1800	2 ³ / ₁₆	3 ³ / ₈	12
TR12216	#16	.1770	2 ³ / ₁₆	3 ³ / ₈	12
TR12217	#17	.1730	2- ³ / ₁₆	3 ³ / ₈	12
TR12218	#18	.1695	2- ¹ / ₈	3 ¹ / ₄	12
TR12219	#19	.1660	2- ¹ / ₈	3 ¹ / ₄	12
TR12220	#20	.1610	2- ¹ / ₈	3 ¹ / ₄	12
TR12221	#21	.1590	2- ¹ / ₈	3 ¹ / ₄	12
TR12222	#22	.1570	2	3 ¹ / ₈	12
TR12223	#23	.1540	2	3 ¹ / ₈	12
TR12224	#24	.1520	2	3 ¹ / ₈	12
TR12225	#25	.1495	1 ⁷ / ₈	3	12
TR12226	#26	.1470	1 ⁷ / ₈	3	12
TR12227	#27	.1440	1 ⁷ / ₈	3	12
TR12228	#28	.1405	1 ³ / ₄	2 ⁷ / ₈	12
TR12229	#29	.1360	1 ³ / ₄	2 ⁷ / ₈	12
TR12230	#30	.1285	1 ⁵ / ₈	2 ³ / ₄	12
TR12231	#31	.1200	1 ⁵ / ₈	2 ³ / ₄	12
TR12232	#32	.1160	1 ⁵ / ₈	2 ³ / ₄	12
TR12233	#33	.1130	1 ¹ / ₂	2 ⁵ / ₈	12
TR12234	#34	.1110	1 ¹ / ₂	2 ⁵ / ₈	12

Item #	Size	Decimal Equivalent	Flute Length	Overall Length	Env. Qty.
TR12235	#35	.1100	1 ¹ / ₂	2 ⁵ / ₈	12
TR12236	#36	.1065	1 ⁷ / ₁₆	2 ¹ / ₂	12
TR12237	#37	.1040	1 ⁷ / ₁₆	2 ¹ / ₂	12
TR12238	#38	.1015	1 ⁷ / ₁₆	2 ¹ / ₂	12
TR12239	#39	.0995	1 ³ / ₈	2 ³ / ₈	12
TR12240	#40	.0980	1 ³ / ₈	2 ³ / ₈	12
TR12241	#41	.0960	1 ³ / ₈	2 ³ / ₈	12
TR12242	#42	.0935	1 ¹ / ₄	2 ¹ / ₄	12
TR12243	#43	.0890	1 ¹ / ₄	2 ¹ / ₄	12
TR12244	#44	.0860	1 ¹ / ₈	2 ¹ / ₈	12
TR12245	#45	.0820	1 ¹ / ₈	2 ¹ / ₈	12
TR12246	#46	.0810	1 ¹ / ₈	2 ¹ / ₈	12
TR12247	#47	.0785	1	2	12
TR12248	#48	.0760	1	2	12
TR12249	#49	.0730	1	2	12
TR12250	#50	.0700	1	2	12
TR12251	#51	.0670	1	2	12
TR12252	#52	.0635	7 ⁸ / ₁₆	1 ⁷ / ₈	12
TR12253	#53	.0595	7 ⁸ / ₁₆	1 ⁷ / ₈	12
TR12254	#54	.0550	7 ⁸ / ₁₆	1 ⁷ / ₈	12
TR12255	#55	.0520	7 ⁸ / ₁₆	1 ⁷ / ₈	12
TR12256	#56	.0465	3 ⁴ / ₁₆	1 ³ / ₄	12
TR12257	#57	.0430	3 ⁴ / ₁₆	1 ³ / ₄	12
TR12258	#58	.0420	1 ¹ / ₁₆	1 ⁵ / ₈	12
TR12259	#59	.0410	1 ¹ / ₁₆	1 ⁵ / ₈	12
TR12260	#60	.0400	1 ¹ / ₁₆	1 ⁵ / ₈	12



TRIUMPH TWIST DRILL CO.
Jobber Length Drills

T3B Series



- 118° Point
- High speed steel
- Black oxide finish
- General purpose use
- Made In USA

Item #	Size	Decimal Equivalent	Flute Length	Overall Length	Env. Qty.
TR13201	A	.2340	2 ⁵ / ₈	3 ⁷ / ₈	12
TR13202	B	.2380	2 ³ / ₄	4	12
TR13203	C	.2420	2 ³ / ₄	4	12
TR13204	D	.2460	2 ³ / ₄	4	12
TR13206	F	.2570	2 ⁷ / ₈	4 ¹ / ₈	12
TR13207	G	.2610	2 ⁷ / ₈	4 ¹ / ₈	12
TR13208	H	.2660	2 ⁷ / ₈	4 ¹ / ₈	12
TR13209	I	.2720	2 ⁷ / ₈	4 ¹ / ₈	12
TR13210	J	.2770	2 ⁷ / ₈	4 ¹ / ₈	12
TR13211	K	.2810	2 ⁵ / ₁₆	4 ¹ / ₄	12
TR13212	L	.2900	2 ⁵ / ₁₆	4 ¹ / ₄	12
TR13213	M	.2950	3 ¹ / ₁₆	4 ³ / ₈	12
TR13214	N	.3020	3 ¹ / ₁₆	4 ³ / ₈	12
TR13215	O	.3160	3 ³ / ₁₆	4 ¹ / ₂	6
TR13216	P	.3230	3 ⁵ / ₁₆	4 ⁵ / ₈	6
TR13217	Q	.3320	3 ⁷ / ₁₆	4 ³ / ₄	6
TR13218	R	.3390	3 ⁷ / ₁₆	4 ³ / ₄	6
TR13219	S	.3480	3 ¹ / ₂	4 ⁷ / ₈	6
TR13220	T	.3580	3 ¹ / ₂	4 ⁷ / ₈	6
TR13221	U	.3680	3 ⁵ / ₈	5	6
TR13222	V	.3770	3 ⁵ / ₈	5	6
TR13223	W	.3860	3 ³ / ₄	5 ¹ / ₈	6
TR13224	X	.3970	3 ³ / ₄	5 ¹ / ₈	6
TR13225	Y	.4040	3 ⁷ / ₈	5 ¹ / ₄	6
TR13226	Z	.4130	3 ⁷ / ₈	5 ¹ / ₄	6

TRIUMPH TWIST DRILL CO.
Jobber Length Drill Sets



Fractional

- Metal Indexes
- Heavy-Duty with Black Oxide Finish (99856 Black & Bronze Oxide)

Item #	Desc.	Range	Style
TR99803	29 Piece T17D	1/16"– 1/2" by 64ths	T17D
TR99809	15 Piece T18D	1/16"– 1/2" by 32ths	T18D
TR99815	13 Piece T19D	1/16"– 1/4" by 64ths	T19D
TR99836	21 Piece T180D	1/16"– 3/8" by 64ths	T180D
TR99856	29 Piece, T17HD	1/16"– 1/2" by 64ths	T17HD

TRIUMPH TWIST DRILL CO.
Screw Extractor and Drill Set

T50CX

- Combination sizes in vinyl pouch
- Set Qty.: 10-piece, Screw Extractor
- Drill Size Range: #1-5 and 5/64, 7/64, 5/32, 1/4, 17/64 in.
- Style: General Purpose, Finish: Gray Finish (Bright Finish Drills)

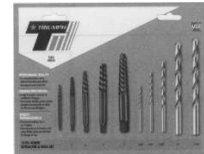

Item #
TR98150



IRWIN INDUSTRIAL TOOLS
6-Piece Wood Boring Bit Set
Speedbor®2000™

- Double cutting spurs scribe the outside of the hole reducing breakout
- Grooved hex shank prevents slipping in drill chuck or bit extension
- Fits all standard quick change chucks



Item #
IR88898

IRWIN INDUSTRIAL TOOLS
13-Piece Wood Boring Bit Set

Set Includes:

- No.-Size: 88804-1/4", 88805-5/16", 88806-3/8", 88807-7/16", 88808-1/2", 88809-9/16", 88810-5/8", 88811-11/16", 88812-3/4", 88813-13/16", 88814-7/8", 88815-15/16", 88816-1"



Item #	Wt
IR88894	1.26



IRWIN INDUSTRIAL TOOLS Wood Boring Bits

- Hex shank
- 6" Speedbor2000® bits



Item #	Diameter (in.)
IR88804	1/4
IR88805	5/16
IR88806	3/8
IR88807	7/16
IR88808	1/2
IR88809	9/16
IR88810	5/8
IR88811	11/16
IR88812	3/4
IR88813	13/16
IR88814	7/8
IR88815	15/16
IR88816	1
IR88818	1 1/8
IR88820	1 1/4
IR88822	1 3/8
IR88824	1 1/2

IRWIN INDUSTRIAL TOOLS Wood Bit Extensions

- Adds extra reach to wood boring bit
- Extension head will follow 5/8" and larger bits through hole; two set screws secure bit into extension



Item #	Overall Length (in.)
IR88702	6
IR88601	12

IRWIN INDUSTRIAL TOOLS Woodboring Drill Bit

Speedbor

- The fastest speedbor spade bit ever; Tri-Flute design for faster chip ejection
- Cutting spurs have 3 cutting edges for added durability
- Full screw tip allows bit to self feed; grooved hex shank prevents slipping in drill chuck or bit extension
- Fits all standard 1/4" quick change chucks
- Shank Length: 6"



Item #	Diameter (in.)
IR3041001	1/2
IR3041002	5/8
IR3041004	3/4
IR3041005	7/8
IR3041007	1
IR3041009	1 1/4

IRWIN INDUSTRIAL TOOLS Woodboring Drill Bit Sets

Speedbor

- The fastest speedbor spade bit ever
- Tri-Flute design for faster chip ejection
- Cutting spurs have 3 cutting edges for added durability
- Full screw tip allows bit to self feed
- Grooved hex shank prevents slipping in drill chuck or bit extension
- Fits all standard 1/4" quick change chucks
- Comes with a heavy-duty case
- Shank Length: 6"



Item #	Desc.
IR3041003	3-pc set includes 5/8", 3/4" and 1"
IR3041006	6-pc set includes 1/2", 5/8", 3/4", 7/8", 1" and 1 1/4"

IRWIN INDUSTRIAL TOOLS Screwdriver Bit Set

16-Piece

- Contents: 1" Insert Bits: #1 Phillips (1), #2 Phillips (2), #3 Phillips (1), #2 Square Recess (2), 8-10 Slotted (1); Nutsetters: 1/4" (1), 5/16" (1), 3/8" (1); 2" Power Bits: #2 Phillips (2), #2 Square Recess (1), 8-10 Slotted (1), 6-8 Slotted (1); 2-1/4" Magnetic Bit Holder (1)



Item #
IR3057014

IRWIN INDUSTRIAL TOOLS Installer Bits

- Constructed of premium alloy steel for drilling into a variety of materials including wood, plaster, and metal lath encountered while installing wire
- Special 82° point for fast drilling
- Hole in flute makes it easy to pull wire through walls, ceilings and floors
- Ideal for installation of small wire for telephones, cable TV, computers and security systems



Item #	Diameter (in.)	Overall Length (in.)
IR39004	1/4	18
IR39005	5/16	18
IR39006	3/8	18
IR39007	7/16	18
IR39008	1/2	18
IR39404	1/4	24
IR39405	5/16	24
IR39406	3/8	24
IR39408	1/2	24
IR39608	1/2	30

IRWIN Industrial Tools

IRWIN INDUSTRIAL TOOLS Magnetic Screw Guide

Retracting Sleeve

- Engineered to hold long fasteners in place
- Screw guide sleeve retracts as the fastener is driven into the work piece
- Magnetic for secure retention of fastener
- Designed for use with insert bits only
- 1/4" Shank Diameter



Item #	Retracted Length (in.)	Extended Length (in.)
IR93553	4 ¹ / ₁₆	7 ⁵ / ₈

IRWIN INDUSTRIAL TOOLS Quick Change Extensions

Irwin® Lock-N-Load®

Chuck and Extensions:

- Slim diameter chuck and extensions pass through 11/16" holes



Item #	Desc.
IR90106	6 in. Quick-Change Extension
IR90112	12 in. Quick-Change Extension

MAG-BIT

MAG-BIT® High Speed Steel Bits

911 Long Boys

- Designed to give the roofing and framing contractor more holes per bit using pre-drilled joist hangers, anchors, caps and connectors
- 1/2" shank with 3 flats
- 118° point

Item #	Size (in.)
MAG911.1016	5/8
MAG911.1116	1 ¹ / ₁₆
MAG911.1216	3/4
MAG911.1316	13/16
MAG911.1416	7/8
MAG911.1516	15/16
MAG911.1616	1
MAG911.1816	1 ¹ / ₈
MAG911.2016	1 ¹ / ₄



MAG-BIT® Extension Bit



- Provided with 2 set screws & hex wrench
- Fits most boring tools with 1/4", 5/16", & 7/16" hex shanks
- 5/16" extensions require bits 5/8" or larger

Item #	Size (in.)
MAG782.12.0516	5/16x12

MORSE THE M. K. MORSE COMPANY

M K MORSE Step Drills

- Excellent tool for electrical contractors, sheetmetal workers and auto mechanics
- Ideal for drilling repetitive holes in steel, copper, brass, plastic, plexiglas and other thin materials
- Made of high speed steel with double fluted ground cutting edge for long life
- TiN (Titanium Nitride) coated step drills last up to six times longer than those made without TiN coating



Item #	Desc.	Shank Inches (in.)
MKESD09	3/4" - 1 3/8" by 16ths	1/2
MKESD08	9/16" - 1" by 16ths	3/8
MKESD07	1/8" - 1/2" by 16ths	1/4
MKESD06	1/8" - 3/8" by 16ths	3/8
MKESD05	1/4" - 1 1/8" by 16ths	3/8
MKESD04	1/4" - 3/4" by 16ths	3/8
MKESD03	3/16" - 7/8" by 16ths	3/8
MKESD02	3/16" - 1/2" by 16ths	1/4
MKESD01	1/8" - 1/2" by 32nds	1/4



HOUGEN MFG., INC.

Carbide Holcutters™

- Cut smooth, fast, burr-free holes in all types of materials, from soft aluminum to tough-to-cut stainless and cast iron
- Features a shoulder stop to prevent over penetration of the work piece
- Ejector Spring helps with slug ejection
- Tungsten carbide provides long tool life and smooth cutting action
- Dramatically outlasts bi-metal hole saws and step drills
- For materials up to 1/8" thick
- All cutters include arbor, pilot and spring
- Made in the USA



Item #	Cutter Dia. (in.)	Decimal Equivalent
HG14322	1 ¹ / ₁₆	.6875
HG14324	3 ⁴ / ₁₆	.7500
HG14326	13 ¹⁶ / ₁₆	.8125
HG14328	7 ⁸ / ₁₆	.8750
HG14330	15 ¹⁶ / ₁₆	.9375
HG14332	1	1.0000
HG14334	1 ¹ / ₁₆	1.0625
HG14336	1 ¹ / ₈	1.1250
HG14338	13 ¹⁶ / ₁₆	1.1875
HG14340	1 ¹ / ₄	1.2500
HG14342	15 ¹⁶ / ₁₆	1.3125
HG14344	1 ³ / ₈	1.3750
HG14348	1 ¹ / ₂	1.5000
HG14352	1 ⁵ / ₈	1.6250
HG14356	1 ³ / ₄	1.7500
HG14362	2	2.0000
HG14366	2 ¹ / ₈	2.1250
HG14368	2 ¹ / ₄	2.2500
HG14372	2 ³ / ₈	2.3750
HG14374	2 ¹ / ₂	2.5000
HG14378	2 ⁵ / ₈	2.6250
HG14380	2 ³ / ₄	2.7500
HG14384	3	3.0000

Pilot Bits

HG14301	1 ¹ / ₁₆ " - 2 ³ / ₈ "
HG14302	2 ¹ / ₂ " - 3"

Ejector Spring

HG14303	1 ¹ / ₁₆ " - 2 ³ / ₈ "
HG14304	2 ¹ / ₂ " - 3"

HOUGEN MFG., INC.
HSS Holcutters™

- For sheet metal and thin materials up to 1/8" thick
- Last 10x longer and cut 3x faster than bi-metal hole saws or twist drills
- Use a single arbor, with a patented Quad-Lead thread mounting system
- Use with 14009 arbor
- Made in the USA



Item #	Cutter Dia. (in.)	Decimal Equivalent
HG14222	1 ¹ / ₁₆	.6875
HG14224	3 ⁴ / ₁₆	.7500
HG14226	13 ¹⁶ / ₁₆	.8125
HG14228	7 ⁸ / ₁₆	.8750
HG14230	15 ¹⁶ / ₁₆	.9375
HG14232	1	1.0000
HG14234	1 ¹ / ₁₆	1.0625
HG14236	1 ¹ / ₈	1.1250
HG14238	13 ¹⁶ / ₁₆	1.1875
HG14240	1 ¹ / ₄	1.2500
HG14242	15 ¹⁶ / ₁₆	1.3125
HG14244	1 ³ / ₈	1.3750
HG14246	17 ¹⁶ / ₁₆	1.4375
HG14248	1 ¹ / ₂	1.5000
HG14250	19 ¹⁶ / ₁₆	1.5625
HG14252	1 ⁵ / ₈	1.6250
HG14254	1 ¹¹ / ₁₆	1.6875
HG14256	1 ³ / ₄	1.7500
HG14260	17 ⁸ / ₁₆	1.8750
HG14262	2	2.0000
HG14264	2 ¹ / ₁₆	2.0625
HG14266	2 ¹ / ₈	2.1250
HG14268	2 ¹ / ₄	2.2500
HG14272	2 ³ / ₈	2.3750
HG14274	2 ¹ / ₂	2.5000
HG14276	29 ¹⁶ / ₁₆	2.5625
HG14278	2 ⁵ / ₈	2.6250
HG14280	2 ³ / ₄	2.7500
HG14282	27 ⁸ / ₁₆	2.8750
HG14284	3	3.0000

Arbor for Quad-Lead thread cutters (3/8" chuck)

HG14009

Pilot for 14009 Arbor

HG13007C



COOPER TOOLS - APEX DIVISION
1/4" Hex Insert Bit

Hex Phillips
Apex

Item #	Point Size	Overall Length (in.)
AP440-1*X	1	1
AP440-2*X	2	1
AP440-3*X	3	1



COOPER TOOLS - APEX DIVISION
1/4" Hex Insert Bit

Limited Clearance Phillips
Apex

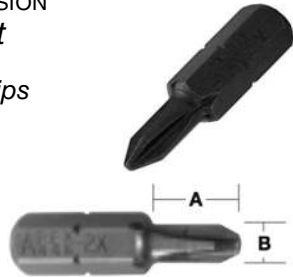

Item #	Point Size	OA Lgth. (in.)	Turned Lgth. (in.)
AP446-1*X	1	1	7/16
AP446-2*X	2	1	7/16

COOPER TOOLS - APEX DIVISION
5/16" Hex Insert Slotted Bit

Phillips
Apex

- 5/16" Hex insert bits
- Phillips bit
- Turned OD (B): 0.108" (4.06 mm)



Item #	Point Size	Overall Length (in.)
AP480-2*X	2	1 1/4
AP480-3*X	3	1 1/4

COOPER TOOLS - APEX DIVISION
1/4" Hex Power Drive Bit

Hex Phillips
Apex

- Universal power notch to fit directly into the power tool for improved concentricity and easier clearance



Item #	Point Size	OA Length (in.)	Body Dia (in.)	Turned Length (in.)
AP491*X	1	1 15/16	3/16	1 1/4
AP491-A*X	1	2 3/4	3/16	2
AP491-B*X	1	3 1/2	3/16	2 3/4
AP491-C*X	1	6	3/16	2
AP492*X	2	1 15/16	1/4	1 1/4
AP492-A*X	2	2 3/4	1/4	2
AP492-B*X	2	3 1/2	1/4	2 3/4
AP492-C*X	2	6	1/4	2
AP493*X	3	1 15/16	5/16	1
AP493-A*X	3	2 3/4	5/16	1 3/4
AP493-B*X	3	3 1/2	5/16	2 1/2

COOPER TOOLS - APEX DIVISION
1/4" Hex Power Drive Bit

Slotted Bit
Apex



Item #	Screw Size	Length (in.)	Blade Thck (in.)	Blade Width/Body Dia. (in.)
AP320-3*X	6F-8R	1 15/16	.038	.250
AP326-3*X	6F-8R	2 3/4	.038	.250
AP320-4*X	8F-10R	1 15/16	.042	.275
AP320-5*X	10F-12R	1 15/16	.046	.312

COOPER TOOLS - APEX DIVISION
1/4" Hex Insert Bit

Slotted
Apex



Item #	Screw Size	Length (in.)	Blade Thck (in.)
AP445-1*X	4F-5R	1	.034 (.86)
AP445-2*X	6F-8R	1	.040
AP445-3*X	8F-10R	1	.042
AP445-4*X	10F-12R	1	.046
Limited Clearance			
AP445-0X	3F-4R	1	.030
AP445-10*X	4F-5R	1	.034 (.86)
AP445-20*X	5F-6R	1	.036



COOPER TOOLS - APEX DIVISION
1/4" Hex Insert Bit

Hex Torx®
Apex



Item #	Driver Size (in.)	OA Length (in.)
AP440-TX-05*X	T-5	.055
AP440-TX-10*X	T-10	1
AP440-TX-20*X	T-20	1
AP440-TX-27*X	T-27	1
AP440-TX-30*X	T-30	1
AP440-TX-45*X	T-45	1 1/4
AP440-TX-08*X	T-8	.090
AP440-TX-15*X	T-15	.128
AP440-TX-25*X	T-25	.173
AP440-TX-40*X	T-40	.260
AP440-TX-50X	T-50	.346

COOPER TOOLS - APEX DIVISION
5/16" Hex Insert Bit

Torx®
Apex



Item #	Point Size	Width of Head (in.)	Overall Length (in.)
AP480-TX-30*X	T-30	.216	1 1/4
AP480-TX-40*X	T-40	.260	1 1/4
AP480-TX-50*X	T-50	.346	1 1/4

COOPER TOOLS - APEX DIVISION
1/4" Hex Power Drive Bit

Hex Torx®
Apex



Item #	Driver Size	Body Dia. (in.)	OA Lgth. (in.)
AP49-A-TX-20	T-20	.171	2 3/4
AP49-A-TX-25	T-25	.193	2 3/4

COOPER TOOLS - APEX DIVISION
1/4" Hex Insert Bit

Square Recess
Apex



Item #	Point Size	Nominal Size (in.)	OA Length (in.)
AP950-0*X	0	1/16	1
AP950-1*X	1	3/32	1
AP950-2*X	2	1/8	1
AP950-3*X	3	9/64	1

COOPER TOOLS - APEX DIVISION
1/4" Hex Power Drive Bit

Square Recess
Apex



Item #	Point Size (in.)	Nominal Size (in.)	Overall Length (in.)
AP954-1*X	1	3/32	15/16
AP954-A-1*X	1	3/32	2 3/4
AP954-B-1*X	1	3/32	3 1/2
AP954-2*X	2	1/8	1 15/16
AP954-A-2*X	2	1/8	2 3/4
AP954-B-2*X	2	1/8	3 1/2
AP954-3*X	3	9/64	1 15/16
AP954-A-3*X	3	9/64	2 3/4
AP954-B-3*X	3	9/64	3 1/2
AP954-C-2*X	2	1/8	6
AP954-C-3*X	3	9/64	6

COOPER TOOLS - APEX DIVISION
1/4" Hex Drive Bit Holder

Magnetic
Apex



Item #	Overall Length (in.)
APM-490	2 31/32
APM-490-2	2
APM-490-6	6



COOPER TOOLS - APEX DIVISION
1/4" Hex Drive Nutsetter

*Magnetic
Apex*



Item #	Size (in.)	OA Length (in.)	Socket Nose Dia (in.)
APMDA-08	1/4	1 3/4	7/16
APMDA-10	5/16	1 3/4	1/2
APMDA-12	3/8	1 3/4	9/16
APMDB-08	1/4	2 9/16	7/16
APMDB-10	5/16	2 9/16	1/2
APMDB-12	3/8	2 9/16	9/16
APMDB-14	7/16	2 9/16	5/8

COOPER TOOLS - APEX DIVISION
1/4" Hex Extension

*Square Drive Socket Adapter
Apex*



Item #	Overall Length (in.)	Type of Lock
1/4" Male Square		
APEX-250-2	2	Pin
APEX-250-B-2	2	Ball
APEX-250-3	3	Pin
APEX-250-6	6	Pin
3/8" Male Square		
APEX-370-B	1/4	Ball
APEX-370-B-2	1/4	Ball
1/2" Male Square		
APEX-500-B-2	2	Ball



IDEAL INDUSTRIES

Powerblade™ Cable Cutter

- Versatile unit fits any drill that accepts a 3/8" drive shaft
- Cuts up to 750 MCM hard-drawn copper and up to 1,000 MCM aluminum
- Hardened steel blades ensure consistent cuts and long-term durability
- Rounded blade design minimizes cable distortion during cutting
- Ergonomic, non-slip handle provides excellent grip and comfort



Item #
ID35-078



MALCO PRODUCTS INC.
TurboShear™

TS1 Drill Attachment



- Inserts into chuck of A/C or cordless drill
- Cuts a variety of building materials
- 20 gauge capacity in galvanized steel

Item #	Desc.
MCTS1	Power assisted metal shears

MALCO PRODUCTS INC.

TurboShear Heavy-Duty™

TSHD Drill Attachment



- Inserts into chuck of 14.4 volt or larger A/C or cordless drill
- Clamping devise is standard with TSHD TurboShear
- Navigates tight patterns and square cuts
- Cuts a variety of building materials with the ability to reposition upside down for greater maneuverability
- 18 gauge capacity in galvanized steel

Item #	Desc.
MCTSHD	Power assisted heavy-duty shears

MALCO PRODUCTS INC.

Fiber Cement Siding TurboShear™



TSF1 Drill Attachment

- Attaches to your existing cordless or A/C drill to go where the work is; straight shearing, precise arcs, fine trimming
- Fast cutting blades are specialized for fiber cement siding only up to 5/16"

Item #	Desc.
MCTSFC	Power assisted fiber cement shears



APEX

APEX Plain Bearing Chuck

Thread Mounted/Heavy-Duty
Jacobs®



- Heavy-duty model for threaded mounting
- Jaws center-ground for absolute straightness and alignment
- Jaws specially treated to ensure extended thread life and high gripping surface hardness
- Fluted sleeve standard

Item #	Maximum Capacity Range in. (mm)	Mount Thread	Key No.	Closed Length Dimension (in.)	Open Length Dimension (in.)	Sleeve Dia. Dimension (in.)	Model No.	Wt
PJA6255	0.250 (6.5)	3/8-24	K7	2.23	1.74	1.33	7BA 3/8	7

APEX Multi-Craft® Drill Chuck Jacobs®



- Ideal for corded or cordless reversible or non-reversible power drills
- Through-hardened jaws for hard, wear resistant gripping surfaces

Item #	Model No.	Cap. Range Min. (in.)	Cap. Range Max. (in.)	Mount Thrd.	Key No.
PJA30598	1/2 Cap.	0.078	0.500	3/8 - 24	KK

APEX Keyless Drill Chuck Jacobs®



- Patented keyless design produces greater bit ripping force than conventional keyed chucks
- Hand-Tite® keyless operation increases operator productivity and convenience by speeding bit changeovers and eliminating downtime caused by loss of chuck keys

Item #	Model No.	Cap. Range Min. (in.)	Cap. Range Max. (in.)	Mount Thrd.	OA Lgth. (in.)
PJA30354	10 mm Cap. (3/8)	0.040	0.375	3/8 - 24	2.00
PJA31038	13 mm Cap. (1/2)	0.062	0.500	1/2 - 20	2.90
PJA31037	13 mm Cap. (1/2)	0.062	0.500	3/8 - 24	2.90

APEX Replacement Chuck Keys Jacobs®



Item #	Pilot Size (in.)	Used On Chuck	Key No.	Handle Type
PJA3649	1/4	2 Series	K2	Thumb
PJA3651	5/16	3, 34 Series & 14N	K3	Thumb
PJA3655	3/8	36, 16, 18N	K4	Thumb
PJA3659	7/32	7 Series	K7	Thumb
PJA3666	1/4	32, 33 Series & 11N	K32	Thumb
PJA30052	9/32	DC8, SM8, 74K, 22BA, 23BA, 24BA, 26BA, 29-33	KK	"T"
PJA14273	1/4	1/4 & 3/8 Multi-Craft (Black Handle)		"T"

APEX

APEX Replacement Keyleashes

Jacobs®



- Keyleash Model A (3685) fits key No. K0, K1, K7, KG
- Keyleash Model B (3686) fits key No. K30, K32, K2, KK

Item #

PJA3685

PJA3686

APEX

Adapt-a-Drive® Chuck

Jacobs®



- Converts any cordless screwdriver to a multi-purpose mini-drill for bit sizes up to 1/4"
- Easy conversion-integral hex mount locks the Adapt-A-Drive chuck into the screwdriver bit socket
- Ideal for use in starting screw holes for use in hard-to-reach spaces
- Mount Thread: .250-Hex
- Key No.: KG1

Item #

PJA30248



BIG FOOT

Saw Adapter Kit

Worm Drive Saws

- Fits Skil® 7-1/4" HD77, HD77M & Bosch® 7-1/4" 1677M
- Allows 3-3/4" depth of cut and will cut any 4x material in one pass
- Kit comes with the new short depth slide, installation instructions, 10-1/4" x 36 carbide blade



Item #

PBF KIT



VOLEX

3 Wire Cord With Moulded Strain Reliefs

Type SJ



- Replaces Milwaukee cord # 22-64-0395

Item #	Gauge/Wires	Length (ft.)	Rating	Plug
PEUC-7661	16/3	9	300 Volt	Moulded Rubber Plug

VOLEX

3 Wire Cord With Moulded Strain Reliefs

Type SJO



- Replaces DeWalt cord # 400366-98

Item #	Gauge/Wires	Length (ft.)	Rating	Plug
PEUC-7430	16/3	10	300 Volt	Moulded Rubber Cord

VOLEX

3 Wire Cord With Moulded Strain Reliefs

Type S



Item #	Gauge/Wires	Length (ft.)	Rating	Plug
PEUC-9196	16/3	10	600 Volt	Moulded Rubber Cord

VOLEX

2 Wire Cord

Type SJ



- C-7308 replaces DeWalt # 448557-98
- C-7330 replaces DeWalt # 330081-08

Item #	Gauge/Wires	Length (ft.)	Rating	Plug
PEUC-7308	18/2	8	300 Volt	Moulded Rubber Plug
PEUC-7330	16/2	10	300 Volt	Moulded Rubber Plug



VOLEX
3 Wire Cord

Type S & SJ



- C-7408 replaces DeWalt cord # 36480-98
- C-7422 replaces DeWalt cord # 36495-98

Item #	Gauge/ Wires	Length (ft.)	Rating	Type	Plug
PEUC-7408	18/3	8	300 Volt	SJ	Moulded Rubber Plug
PEUC-7422	16/3	12	300 Volt	SJ	Moulded Rubber Plug



HOUGEN MFG., INC.
HSS Holcutters™ Kit



- Sturdy plastic case contains Arbor, Pilots, Hex Washer, instructions, and HSS Holcutters: 7/8, 1-1/8, 1-3/8, 1-3/4, 2 & 2-1/2"
- For sheet metal and thin materials up to 1/8" thick
- Last 10x longer and cut 3x faster than bi-metal hole saws or twist drills
- Use a single arbor, with a patented Quad-Lead thread mounting system
- Use with 14009 arbor
- Made in the USA

Item #	Desc.
HG14005C	6 Cutter Kit

Don't see what you are looking for? Call us and we'll do our best to track it down.

Edge is a warranty repair center for most major lines.

Need repair parts . . . then give us a call.

Don't want to buy? Give us a call and inquire about renting.

RIDGID

RIDGE TOOL CO.
Pipe Wrench

Straight Cast Iron Housing



- I-beam handle for comfortable grip and strength without excess weight
- Full-floating forged hook jaw with spring suspension for instant grip, instant release
- Uniquely braced, extra-strong mount for heel jaw

Item #	Length (in.)	Pipe Cap. (in.)
RI31000	6	3/4
RI31005	8	1
RI31010	10	1 1/2
RI31015	12	2
RI31020	14	2
RI31025	18	2 1/2
RI31030	24	3
RI31035	36	5
RI31040	48	6
RI31045	60	8

RIDGE TOOL CO.
End Pipe Wrench
Cast-Iron Housing



- Assures a fast and easy grip for pipe working in restricted spaces or close to a wall

Item #	Size (in.)	Pipe Cap. (in.)
RI31065	12	2
RI31075	18	2 1/2
RI31080	24	3

RIDGE TOOL CO.
Pipe Wrenches
Compound Leverage



The original heavy-duty pipe wrench with types and sizes to fit every application.

- Sturdy cast-iron housing and I-beam handle for comfortable grip and strength without excess weight
- Full-floating forged hook jaw with spring suspension for instant grip, instant release

Item #	Model No.	Pipe Capacity (in.)
RI31385	S-6A	6

RIDGE TOOL CO.
Pipe Wrench
Straight Aluminum Handle



- Nearly 40% lighter than comparable cast-iron models of the same size
- Jaws and all other parts identical to Ridgid® heavy-duty wrenches

Item #	Length (in.)	Pipe Cap. (in.)
RI31090	10	1 1/2
RI47057	12	2
RI31095	14	2
RI31100	18	2 1/2
RI31105	24	3
RI31110	36	5
RI31115	48	6

RIDGE TOOL CO.
Offset Pipe Wrench
Aluminum Handle



- Aluminum handle offset pipe wrench
- Nearly 50% lighter than comparable cast-iron models of the same size
- Features a jaw opening parallel to the handle and a narrower hook jaw head which provides easy entry into tight spots

Item #	Nom. Size	Pipe Cap. (in.)
RI31120	14	2
RI31125	18	2 1/2
RI31130	24	3

RIDGE TOOL CO.
End Wrench
Aluminum
Model E-910



- Ideal for jobs in close quarters and overhead applications
- Designed for easy access in close parallel lines
- 40% lighter than heavy-duty wrenches
- Nom. Size: 10"
- Pipe Capacity: 1-1/2"

Item #
RI90107

RIDGE TOOL CO.
1-1/8" to 2-5/8" Hex Wrench
Offset



- Cast iron housing and I-beam handle
- Hex jaw design gives multi-sided, secure grip on all hex nuts, square nuts, unions, and valve packing nuts
- The extra-wide opening offset model is ideal for securing drain nuts on sinks and tubs
- Length: 9-1/2"
- Capacity: 1-1/8" - 2-5/8"

Item #
RI31305



RIDGID

RIDGE TOOL CO.
Chain Wrenches



- A double jaw gives fast, ratchet-like action in either direction
- The heavy-duty model has replaceable alloy steel jaws
- The light-duty model has a one-piece forged alloy steel handle and jaw; ideal for use in close quarters

Item #	Model No.	Desc.	Rated Pipe Cap. (in.)	Actual O.D. Capacity (in.)	Chain Length (in.)
RI31310	C-12	Light-Duty Chain	2	4	15¾
RI31315	C-14	Heavy-Duty Chain	2	5	18½
RI31320	C-18	Heavy-Duty Chain	2½	5	20¼
RI31325	C-24	Heavy-Duty Chain	3	5	20¼
RI31330	C-36	Heavy-Duty Chain	4½	7½	29

RIDGE TOOL CO.
Strap Wrench



For Polished Pipe

- Best for any polished pipe
- Strong, woven nylon strap gives tight grip
- Polyurethane-coated strap prevents scratching

Item #	Handle Lgth. (in.)	Strap Lgth. (in.)	Strap Width (in.)	Pipe Cap. (in.)	Tube Cap. OD (in.)
RI31340	11¾	17	1⅞	2	3½
RI31345	11¾	30	1⅞	2	5½
RI31350	11¾	24	1⅞	2	5½
RI31355	11¾	17	1⅞	2	3½
RI31360	18	29¼	1¾	5	7
RI31365	18	48	1¾	5	12

RIDGE TOOL CO.
Spud Wrench

Narrow Jaws

12" Spud wrench features narrow jaws to fit into tight places. Smooth, toothless jaws ideal for square or rectangular stock.

- Length (in.): 12
- Capacity (in.): 3/8 - 2-5/8



Item #
RI31400

RIDGE TOOL CO.
Internal Wrench

Eccentric Action Jaws

Holds closet spuds and bath, basin and sink strainers through 2". Use to install or extract 1" through 2" nipples. Jaws expand by eccentric action and are reversible for various sizes.

- Internal wrench
- Length (in.): 4-1/2
- Capacity (in.): 1-2



Item #	Model No.
RI31405	342

RIDGID

RIDGE TOOL CO.
Basin Wrench

Spring Loaded Jaw



- Spring-loaded jaws of forged alloy steel provide fast, one-hand ratcheting
- Tension plug holds head in any position up to 90° angle

Item #	Model	Lgth. (in.)	Cap. (in.)
RI31175	1017	10-17	3/8-1 1/4
RI31180	1019	10-17	1/4 - 2 1/2

RIDGE TOOL CO.
Torque Wrench

For Soil Pipe Couplings

- The 3/8" drive tightens with a fast ratchet action until the wrench clicks for accurate 80 inch-pounds torque
- For no-hub cast-iron soil pipe couplings



Item #
RI14988

RIDGE TOOL CO.
Faucet & Sink Installer

- Extra long to turn hard to reach mounting nuts on faucets, sprayers and ball cocks
- Notched ends engage 2, 3, 4 and 6 tab basin nuts
- Open slot allows easy access over existing supply lines
- Shutoff valve attachment turns hard to reach angle stops without marring chrome
- Strainer basket attachment holds drain unit in place while tightening strainer nut
- Works with 7/8" & 1" metal or plastic hex nuts
- Light-weight, high strength plastic construction with durable aluminum inserts



Item #
RI66807

RIDGE TOOL CO.
Pipe Vise

Bench Yoke Type

- Yoke and base made of strong, dependable iron
- Hardened alloy steel jaws and convenient pipe rest and bender

Item #	Pipe Cap.
RI40085	1/8-2 1/2



RIDGE TOOL CO.
Pipe Wrench Parts

- Listed below are repair parts for Ridgid® pipe wrenches:

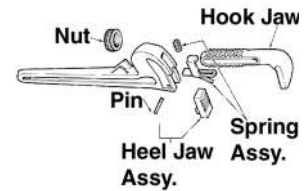

Item #	Part Desc.	Size (in.)
RI31555	Hook Jaw	6
RI31570	Nut	6
RI31580	Hook Jaw	8
RI31585	Heel Jaw Assy.	8
RI31595	Nut	8
RI31605	Hook Jaw	10
RI31610	Heel Jaw Assy.	10
RI31615	Nut	10
RI31630	Hook Jaw	12
RI31635	Heel Jaw Assy.	12-14
RI31655	Hook Jaw	14
RI31660	Spring Assy.	14
RI31665	Nut	14
RI31670	Hook Jaw	18
RI31675	Heel Jaw Assy.	18
RI31680	Spring Assy.	18
RI31685	Nut	18
RI31695	Hook Jaw	24
RI31700	Heel Jaw Assy.	24
RI31705	Spring Assy.	24
RI31710	Nut	24
RI31720	Hook Jaw	36
RI31725	Heel Jaw Assy.	36
RI31730	Spring Assy.	36
RI31735	Nut	36
RI31745	Hook Jaw	48
RI31750	Heel Jaw Assy.	48
RI31760	Nut	48
RI31765	Pin	48
RI31775	Heel Jaw Assy.	60
RI31790	Pin	60



RIDGID

RIDGE TOOL CO.

Portable Tristand Vise

- Portable tristand vises - integral legs and tray fold in for easy carrying and setup
- Large vise base overhangs front legs for clear tool swing
- Complete with slots for hanging tools, pipe rest, three pipe benders, and ceiling brace screw
- Jaw for Plastic Pipe available for RI72037; order separately



Item #	Model #	Pipe Cap. (in.)	Desc.	Weight (lb.)
RI40130	40-A	1/8-2 1/2	Yoke	48 1/2
RI16703	425	1/8-2 1/2	Chain	32
RI72037	460	1/8-6	Chain	47

RIDGE TOOL CO.

Bench Chain Vise

Top Screw

- Crank handle is anchored to base
- Rugged cast-iron base has jaws of hardened alloy steel, handy pipe rest, and bender



Item #	Pipe Cap. (in.)
RI40185	1/8-2 1/2
RI40195	1/8-4
RI40210	1/4-6
RI40215	1/2-8

RIDGE TOOL CO.

Bench Chain Vise

- Crank handle is anchored to base
- Rugged cast-iron base has handy pipe rest and bender. Capacities of 1/8" through 8"
- Two models available for plastic pipe. Toothless jaws are neoprene-coated to prevent scoring of pipe



Item #	Model No.	Desc.	Pipe Capacity (in.)
RI40205	BC510	Top Screw Bench Chain Vise	1/8 - 5

RIDGE TOOL CO.

Pipe Welding Vise

- Made of durable performance-proven material and designed to resist strain, heat and warpage during tacking
- Machined swivel nuts and pins, together with special chain screws, give smooth and trouble-free assembling of the vise onto pipe



Item #	Model No.	Desc.	Pipe Capacity (in.)
RI40220	461	Straight Pipe Welding Vise	1/2-8

RIDGE TOOL CO.

Pipe Cutters

Heavy-Duty

- Fast, clean pipe cutting by hand or power
- Extra-long shank protects adjustment threads, while an extra-large handle is provided for quick, easy adjustment
- Can be converted to 3-wheel cutter by replacing rollers with cutter wheel, or the 2-A and 4-S can be ordered as 3-wheel model for use in areas where a complete turn is not possible



Item #	Model No.	Nom. Pipe Cap.
RI32820	2-A	1/8-2
RI32825	2-A	1/8-2
RI32830	3-S	1-3
RI32840	4-S	2-4
RI32850	6-S	4-6

RIDGE TOOL CO.

Pipe Cutters

4-Wheel

- Designed for work in areas where a complete turn is impossible
- No. 42-A has a short handle for use in confined areas where only a 130° turn can be made
- Second handle on No. 44-S makes two-man leverage possible for large pipe sizes
- Both equipped with four heavy-duty wheels



Item #	Model No.	Nom. Pipe Cap.
RI32870	42-A	3/4-2
RI32880	44-S	2 1/2-4

RIDGID

RIDGE TOOL CO. **Pipe Cutter**

Wide-Roll Model 202

- Featuring extra-wide rolls, this cutter is especially designed for use with power drives; the wide rolls provide for true tracking and cleaner cuts
- Pipe Capacity: 1/8"-2



Item #
RI32895

RIDGE TOOL CO. **Soil Pipe Cutter**

No. 226

The new, compact, lightweight Ridgid Model 226 In-Place Soil Pipe Cutter is ideal for use on cast iron and clay pipe in service applications where space is limited, such as against the wall or overhead.



Item #
RI69982

RIDGE TOOL CO. **Soil Pipe Cutters**

No. 206

- No. 206: Cuts 1-1/2"-6" No Hub® soil pipe
- Lighter weight and closer spacing of cutter wheels, together with simple ratcheting action, give smooth cut on lighter wall pipe
- Ratchet-action handle parallel to pipe allows for application in trenches of minimum width
- Complete with hand guard to protect operator's knuckles when cutting



Item #	Model No.	Desc.	Capacity (in.)	Capacity (mm)	Replmt. Chain Cat#
RI68650	206	Soil Pipe Cutter No Hub®	1½ - 6	50 - 150	33670

RIDGE TOOL CO. **Soil Pipe Cutter**

No. 246

- Cuts 2"-6" clay, cast-iron, asbestos, cement pipe, and 4" class 22 water main
- Ratchet action handle parallels pipe so trench can be minimum width
- Complete with hand guard to protect operator's knuckles at time of cut



Item #
RI32900

RIDGE TOOL CO. **Soil Pipe Cutter**

No. 276

Provides one stroke cutting of 1-1/2" - 6" service weight, No Hub® soil pipe, clay, asbestos and cement pipe. Makes repeated cuts quickly.

- Expand capacity up to 8" service weight soil pipe by ordering (1) Catalog No. 33665 chain extension assembly



Item #
RI74207

RIDGE TOOL CO. **Pipe Taps**

Hand Use Only

- Made from carbon steel in right hand configuration only
- These taps are especially suited for restricted area work
- All taps have taper of 3/4" per foot
- Marked with drill size for pilot hole



Item #	Drill Size (in.)	Nom. Pipe Size (in.)	Threads Per Inch
RI35815	2 ¹ / ₆₄	1/8	27
RI35820	7 ¹ / ₁₆	1/4	18
RI35825	9 ¹ / ₁₆	3/8	18
RI35830	45 ¹ / ₆₄	1/2	14
RI35835	29 ¹ / ₃₂	3/4	14
RI35840	9 ¹ / ₆₄	1	11 1/2
RI35845	13 ¹ / ₆₄	1 1/4	11 1/2
RI35850	14 ⁷ / ₆₄	1 1/2	11 1/2
RI35855	2 ¹⁵ / ₆₄	2	11 1/2

We Rent & Repair Ridgid Equipment



RIDGID

RIDGE TOOL CO.

Pipe Cutter Wheels

Item #	Blade Exp. (in.)	Fits	Application/Material
RI33100	.312	Models 1A, 2A, 202, 42A, 360, 802/364, 732	Steel Grey Pipe & Ductile Iron
RI33105	.312	Models 42A, 1A, 2A, 202, 360, 802/364, 732	Steel Grey Pipe & Ductile Iron
RI33110	.312	F-3S	S.S. Pipe
RI33115	.132	Models 1A, 2A, 42A, 202, 360, 802/364, 732	Grey Cast Iron
RI33120	.411	Models 3S, 4S, 44S, 466C, 466S, 466HWS, 468S, 468HWS, 472S, 472HWS, 764	Steel Grey Pipe & Ductile Iron
RI33125	.411	Models 44S, 3S, 4S, 466C, 466S, 466HWS, 468S, 468HWS, 472C, 472S, 472HWS, 764	Steel Grey Pipe & Ductile Iron
RI33130	.411	F-229S	S.S. Pipe
RI33145	.470	Model 6S, 208, 209	Steel & Ductile Iron
RI33150	.470	F-367S	S.S. Pipe
RI33155	.265	F-383	Grey Cast Iron
RI33220	.360	E-109	Cast Iron
RI33225	.244	E-2632	Grey Cast Iron
RI44185	.450	42A, 202, 802/ 364, 732	Steel Pipe & Ductile Iron
RI44190	.450	E-1032S	S.S. Pipe



RIDGE TOOL CO.

Cutter Wheels

Tubeing

- Replacement cutter wheels for tubing cutters

74720: Model Nos.: 131P/151P, 132P/152P, 153P, 205P denotes cutter wheel furnished with original

33175: Model Nos.: 30, 40, 134/154, 136/156 denotes alternate cutter wheel

*

Item #	Model No.	Std. Pk.	Blade Exp.	Application
RI33160	F-158		Aluminum Copper	
RI33165	E-1240		Steel/Stainless Steel	
RI33170	E-2558		Aluminum & Copper	
RI33175	E-2191	6	.292	Steel Tubing
RI33180	E-5299	6	.412	PVC, ABS, Std. Wall
RI33185	E-3469		Aluminum & Copper	
RI33190	E-4546		Steel/Stainless Steel	
RI33195	E-5272	6	.290	PVC, ABS, Std. Wall
RI33200	E-1740		Soft Flexible Plastic	
RI33205	E-2990	1	.112	Steel, Aluminum & Copper
RI74720	E-2155	1	.286	PE, PB, PP, Std. & Heavy Wall
RI74730	E-2156		PE, PB, PP, STD & Hvy Wall	

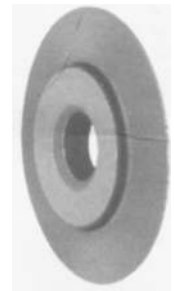

RIDGID

Pipe Reamers

- No. 2-S Spiral Ratchet Reamers - Self-feeding spiral design for extra-fast and easy hand reaming (Model 2-S not suitable for power reaming)
- Nos. 2 & 3 Ratchet Reamers - Ratchet Reamer - Long taper design will not dig in; suitable for use with power drives
- No. 254 Spiral Ratchet Reamer - Hollow center reduces weight; large pressure plate; hardened alloy steel cone removable for sharpening (not suitable for power reaming)
- All reamers include handle



Item #	Model No.	Desc.	Capacity (in.)	Weight (lb.)	Replacement Cone Cat. No.
RI34945	2	Straight Reamer	1/8 - 2	7	34975
RI34950	3	Straight Reamer with Handle	3/8 - 3	11 1/2	35090
RI34955	2-S	Spiral Reamer	1/4 - 2	7 1/4	35020
RI34960	254	Spiral Reamer with Handle	2 1/2 - 4	14	35135

RIDGE TOOL CO.

Pipe Extractors

- Ridgid pipe extractors make easy work of removing broken threaded ends of pipe, pipe plugs, fittings, etc.
- Each is plainly marked showing drill size used when solid ends of plugs and fittings must be drilled to receive extractor



Item #	Pipe Size (in.)	OA Lgth. (in.)	Use Drill Size (in.)
RI35600	1/4	2 1/2	3/8
RI35605	3/8	2 3/4	1/2
RI35610	1/2	3	5/8
RI35615	3/4	3 1/4	1 3/16
RI35620	1	3 1/2	1 1/16
RI35625	1 1/4	3 3/4	1 3/8
RI35630	1 1/2	4	1 9/16
RI35635	2	4 1/2	2 1/16

RIDGE TOOL CO.

Pipe Extractor Sets

Pipe Tools

- Ridgid pipe extractors make easy work of removing broken threaded ends of pipe, pipe plugs, fittings, etc.
- Each is plainly marked showing drill size used when solid ends of plugs and fittings must be drilled to receive extractor



Item #	Model No.	Cap./Pipe Size (in.)	Cap./Pipe Size (mm)	Set Includes
RI35685	883	1/8-1	3-25	Nos. 80 to 85 Inclusive

RIDGE TOOL CO.

Copper Cutting and Prep Machine

Model 122

This machine is designed to cut, clean, ream*, and debur 1/2" to 2" copper tubing and fittings quickly and professionally. Weighing only 50 pounds and possessing a conveniently located carrying handle, the Model 122 is ideal for transport directly to the job site.

*Reams up to 2" in diameter

- Core Reamer easily removes turbulence-causing burrs
- Built-in 1/2" - Incremental Scale for quick, easy measuring



Item #

RI93492



RIDGID

RIDGE TOOL CO.
Power Pipe Cutter
2-1/2" to 8"
Model 258



The Ridgid Model 258 Power Pipe Cutter is uniquely engineered to cut 2-1/2" to 8" schedule 10/40 steel pipe, galvanized pipe, rigid conduit etc. at the job site or in the shop

- Powered by the Ridgid No. 700 Power Drive, the 258 is a displacement cutter that provides square cuts
- Great for cutting pipe for groove joining
- Adaptable for beveling

Specifications:

- Cutting capacity: 2-1/2" to 8" schedule 10*/40 steel pipe

Standard Equipment:

- One Ridgid 774 square drive adapter; one 8-1/2" HD cutter wheel assembly; one hydraulic ram and foot pump; two 2-1/2" to 12" ball transfer pipe supports

Item #

RI50767

RIDGE TOOL CO.
8-1/2" H-D Cutter Wheel
Model E-258



Item #

RI50812

RIDGE TOOL CO.
Tubing Cutters

Midget - Close Quarters



- Specifically designed for use in restricted spaces on small diameter, hard and soft copper, aluminum, brass and plastic tubing, rollers include grooves for close-to-flare cuts
- Strong, lightweight slide and wheel housing, large knurled feed screw knob gives easy control of cutting pressure for clean cuts
- Model 117 includes a self-feeding cutter wheel that automatically cuts after tightening the knob only once (AUTOFEED™), as well as a special knob for easier tightening of the feedscrew
- Models 110 and 117 include spare cutter wheel in knob

Item #	Model No.	Desc.	Capacity (in.)
RI40617	101	Close Quarters Cutter	1/4 - 1 1/8
RI32975	103	Close Quarters Cutter	1/8 - 5/8
RI32985	104	Close Quarters Cutter	3/16 - 1 5/16
RI97787	117	Close Quarters AUTOFEED™ Cutter	3/16 - 5/16

RIDGE TOOL CO.
Tubing Cutters

Enclosed Feed Screw



- Features an enclosed feed screw to eliminate clogging and jamming, grooved rolls for close-to-flare cuts, and a fold-away reamer
- Cuts copper, brass, and aluminum tubing, and thin-wall conduit
- Model 205 has all the features of the No. 150, plus a quick-acting mechanism.

Item #	Model No.	Desc.	Cap. (in.)
RI31622	150	Enclosed Feed Cutter	1/8-1 1/8
RI31627	150	Above W/H-D Wheel(s)	1/8-1 1/8
RI33055	205	Ratcheting Enclosed Feed Cutter	1/4-2 3/8

RIDGE TOOL CO.
Tubing & Conduit Cutters

With New X-CEL Features

- Clean, square cuts are easily made on copper, brass, aluminum, and thin-wall conduit
- Now includes X-CEL Knob for quicker cutting
- Nos. 10, 15 and 20 feature a convenient fold-away reamer
- No. 30 is rated for larger diameter steel and stainless steel tubing
- No. 65S is especially designed for stainless steel tubing; includes six individual bearings and cutter wheel to make stainless cutting easier



Item #	Model No.	Desc.	Std. Wheel	Capacity (in.)
RI32910	10	Tubing and Conduit Cutter	F-158	1/8-1
RI32915	10	Above w/H-D Wheel	E-1240	1/8-1
RI32920	15	Tubing and Conduit Cutter	F-158	3/16-1 1/8
RI32925	15	Above w/H-D Wheel	F-58	3/16-1 1/8
RI32930	20	Tubing and Conduit Cutter	F-158	5/8-2 1/8
RI32935	20	Above w/H-D Wheel	E-1240	5/8-2 1/8
RI32950	30	Above w/H-D Wheel	E-2191	1-3 1/8

RIDGID

RIDGE TOOL CO. 1/4 to 4-1/2" Tubing Cutters



Quick Acting I-Beam Construction

- Models 151-156 feature a quick-acting design, I-beam construction, hardened wear surfaces and thrust bearing slide assemblies for smooth operation
 - All models now include an X-CEL Knob and X-CEL Pin for quicker cutting and wheel replacement
 - These cutters are available in models for plastic pipe or metallic tubing
 - Models 151 and 152 feature fold-away reamers
- *Plastic models do not include a spare cutting wheel
** Nominal plastic pipe size

Item #	Model #	Desc.	Std. Wheel	Cap. (in.)
RI31632	151	Quick-Acting Cutter	E-3469	1/4-1 5/8
RI31637	151-P	Above w/Wheel for Plastic	E-2155	1/8-1 1/4**
RI31642	152	Quick-Acting Cutter	E-3469	1/4-2 5/8
RI31647	152-P	Above w/Wheel for Plastic	E-2155	1/4-2**
RI36597	153	Quick-Acting Cutter	E-3469	1 1/4-3 1/2
RI36592	153-P	Above w/Wheel for Plastic*	E-2155	1-3**
RI31652	154	Quick-Acting Cutter	E-2558	1 7/8-4 1/2
RI31657	154-P	Above w/Wheel for Plastic*	E-2156	1 1/2-4**
RI31662	156	Quick-Acting Cutter	E-2558	4-6 5/8

RIDGE TOOL CO. Tubing Cutters

Internal

- For trimming tubing below floor level for shower/floor drain installations, or above the ceiling for sprinkler head installations
- Each model features hardened steel rollers and cutter wheels



Item #	Model No.	Desc.	Std. Wheel	Capacity (in.)
RI33005	106	Internal Cutter	E-2558	2 - 3 Nominal 1/4 - 2 5/8 Depth
RI83295	109-P	Above W/ Wheel for Plastic	E-5299	2 1/4 - 4 O.D. 1/4 - 2 1/8 Depth

RIDGE TOOL CO.

Plastic Pipe Cutter

PCB-1375

- For PC-1375 Single Stroke Plastic Pipe and Tubing Cutter

Item #

RI25588



RIDGE TOOL CO.

Plastic Pipe Cutters

Scissor-Style

PC-1250

- X-CEL blade - Quick change, reversible blade provides two times blade life
- Spring loaded handles for faster positioning



Item #	Model No.	Desc.	Capacity (in.)
RI23488	PC-1250	Scissor-Style Plastic Pipe & Tubing Cutter	1/8-1 5/8
RI26803	PCB-1250	PC-1250 Replacement Blade	-

RIDGE TOOL CO.

Pipe Cutter

For Plastic Pipes & Tubing

The New Model PC-1375 Single Stroke Plastic Pipe and Tubing Cutter uses a patent-pending X-CEL™ blade to ensure optimum mechanical advantage throughout the cut stroke. The X-CEL blade allows fast, single stroke cutting of PVC, CPVC, PEX, PE, PB and rubber hose up to 1.375" outside diameter. The PC-1375 is designed for the professional user and is constructed of heavy duty aluminum for increased durability.

- Patent pending, X-CEL blade for fast single stroke cutting. No Ratcheting or Twisting Required!
- Durable aluminum construction for heavy duty use.
- Extra large 1.375" O.D. capacity.
- Ergonomic grips on bottom handle are spaced at 1/2 " increments to act as a quick pipe measuring scale.
- Easy turn-thumb latch for reliable storage.
- Replaceable, hardened steel cutting blade.
- Spring-loaded handles provide instant adjustment to any pipe size.
- Burrless cutting operation provides a square cut.

Item #

RI23493





RIDGID

RIDGE TOOL CO. **Replacement Cutter Blade**

RCB-2375

- For RC-2375 Ratchet Action Plastic Pipe & Tubing Cutter

Item #

RI30093



RIDGE TOOL CO. **Ratcheting Plastic Pipe & Tube Cutter**

Large Diameter

RC-2375

The New Model RC-2375 Large Diameter Ratcheting Plastic Pipe and Tubing Cutter expands RIDGID®'s product offering for plastic pipe specific tools. The advanced blade design combined with the ratcheting mechanism, work together to reduce the amount of hand force needed to cut through hard plastic material.

A quick-change blade pin enables the user to change blades in a matter of seconds without tools, saving valuable time and increasing productivity. This pin also assures that there will be no lost clips or misplaced screws during a blade change.

With a 23/8" (63 mm) O.D. capacity, the RC-2375 easily cuts plastic pipe and tubing such as PVC and CPVC, as well as PEX, polyethylene, polybutylene and rubber hose.

- Durable aluminum construction for heavy duty use
- Ergonomic grips on bottom handle are spaced at 1/2" increments to act as a quick pipe measuring scale
- Easy turn-thumb latch for reliable storage
- X-CEL™ quick change blade
- Burrless cutting operation provides a square cut
- Capacity (O.D.): 1/2" – 2 3/8" (12 mm – 63 mm)
- Standard Pack: 6

Item # Wt

RI30088 2



RIDGE TOOL CO. **Fitting Brushes**

- Small internal brushes for refrigeration and air conditioning

Item # Size (in.)

RI42250	1/2
RI42260	1
RI42265	1 1/4
RI42270	1 1/2
RI42275	2
RI42280	2 1/2



RIDGE TOOL CO.

Inner/Outer Reamer

- No. 127 Inner-outer reamer for quick, clean and easy I.D. reaming and O.D. beveling of 1/4" through 1-1/4" pipe
- Long-wearing alloy steel blades give fast, professional reaming on PVC, ABS, CPVC and other types of PB and PE plastics

Item #

RI34965



RIDGE TOOL CO.

Deburring Tool

Deburring tool for plastic pipe and tubing. Ideal for removing outside ridges and inside burrs on plastic pipe and tubing.

- Model No.: 72

Item #

RI35155



RIDGE TOOL CO.

Manual Ratchet Threaders

Exposed Ratchet Threader Sets

- All matched threader/sets include die heads, ratchet assembly, ratchet handle, and alloy dies
- Use Ridgid® thread cutting oil

Item # Capacity (in.) Model #

RI36355	3/8 - 1	00-R
RI36475	1/2 - 2	12-R



RIDGE TOOL CO.

Ratchet and Handle Only

For Manual Threader

- Replacement ratchet and handle accessory for the following manual pipe threaders
- Ratchet knob indicates forward and reverse; die heads snap in from both sides and lock in place

Item # Fits

RI38540	00 - R
RI30118	12 - R



RIDGID

RIDGE TOOL CO.

Pipe Die Head Complete

Right Hand Threaders Alloy - (NPT)



Listed below are complete die heads:

Item #	Desc.	Nom. Pipe Size (in.)
--------	-------	----------------------

Model No. 00-R

RI36875	Alloy RH	1/8 NPT
RI36880	Alloy RH	1/4 NPT
RI36885	Alloy RH	3/8 NPT
RI36890	Alloy RH	1/2 NPT
RI36895	Alloy RH	[3/4] NPT
RI36900	Alloy RH	1 NPT

Model No. 12-R

RI37375	Alloy RH	1/8 NPT
RI37380	Alloy RH	1/4 NPT
RI37385	Alloy RH	3/8 NPT
RI37390	Alloy RH	1/2 NPT
RI37395	Alloy RH	3/4 NPT
RI37400	Alloy RH	1 NPT
RI37405	Alloy RH	1 1/4 NPT
RI37410	Alloy RH	1 1/2 NPT
RI37415	Alloy RH	2 NPT
RI37480	High-Speed RH	1/2 NPT
RI37485	High-Speed RH	3/4 NPT
RI37490	High-Speed RH	1 NPT
RI37495	High-Speed RH	1 1/4 NPT
RI37500	High-Speed RH	1 1/2 NPT
RI37505	High-Speed RH	2 NPT
RI37570	Alloy RH	1/2 NPSM

Model No. 00-RB

RI37610	Alloy RH	1/4 UNC - 20 TPI
RI37615	Alloy RH	5/16 UNC - 18 TPI
RI37620	Alloy RH	3/8 UNC - 16 TPI
RI37625	Alloy RH	7/16 UNC - 14 TPI
RI37630	Alloy RH	1/2 UNC - 13 TPI
RI37635	Alloy RH	9/16 UNC - 12 TPI
RI37640	Alloy RH	5/8 UNC - 11 TPI
RI37645	Alloy RH	3/4 UNC - 10 TPI
RI37650	Alloy RH	7/8 UNC - 9 TPI
RI37655	Alloy RH	1 UNC - 8 TPI

RIDGE TOOL CO.

Receding Threader

High-Speed Dies No. 65R-C

- Threads 1"-2" NPT pipe
- Jam-proof drive pawl
- Cam workholder sets instantly
- Right-hand only



Item #

RI36565

RIDGE TOOL CO.

Pipe Die Set

For 65R-C & 65R-TC Receding Threaders

NPT High Speed - Right Hand

- For 65R-C & 65R-TC Receding Threaders



Item # Size (in.)

RI38100 1-2 - 1 1/2 TPI

RIDGE TOOL CO.

Pipe Die Set

For 4PJ Geared Pipe Threaders

NPT High Speed Right Hand

- For 4PJ Geared Pipe Threaders



Item # Size (in.)

RI38220 2 1/2 - 8

RI38225 3 - 8

RI38235 4 - 8

RIDGE TOOL CO.

Geared Threaders

Nos. 141/161

- 141 threads 2-1/2", 3", 3-1/2", 4" pipe with one set of dies
- 161 threads 4", 4-1/2", 5", 6" pipe with one set of dies
- Jaw clutch prevents jamming
- Simple adjustment for tapered or straight threads
- Right-hand only



Item #	Desc.	Capacity Nominal Pipe Size (in.)
--------	-------	-------------------------------------

RI36620 NPT with 1 Set High-Speed Dies 2 1/2 - 4

RI36630 NPT with 1 Set High-Speed Dies 4 - 6



RIDGID

RIDGE TOOL CO.
Pipe Die Set

For 141 Geared Pipe Threaders
NPT High Speed Right Hand

- For 141 Geared Pipe Threaders

Item #	Size (in.)
RI38120	2½ thru 4 - 8 TPI



RIDGE TOOL CO.

Dies For 161 Geared Pipe Threaders
Ridgid™

- For 161 Geared Pipe Threaders

Item #	Thrd.	Die Mat. or Type	Size - TPI (in.)
RI38155	NPT	High-Speed. For PVC RH	4 thru 6 - 8



RIDGE TOOL CO.

Thread Cutting Oil

- Cools threads and pipe during operation
- Speeds metal removal
- Improves thread quality
- Reduces threading torque
- Sulfur reacts with metal being threaded to form a tough chemical film between the die-cutting edge and threaded material; this reduces friction, galling and prevents fluid rupture by tool pressure
- Ridgid® thread cutting oils are free of chlorine and other halogens, PCBs and heavy metals; they are listed as non-carcinogenic
- Flip top included with every quart bottle



Item #	Size
--------	------

Nu-Clear Plus

RI70835	1 Gal.
RI41575	5 Gal.

Dark

RI41590	1 Qt.
RI70830	1 Gal.
RI41600	5 Gal.
RI41610	55 Gal.

Extreme Performance

RI74012	1 Qt.
RI74047	1 Gal.
RI76767	1 Gal.
RI22088	16 oz. Aerosol Can

RIDGE TOOL CO.

No. 418 Oiler

The new model 418 hand-held oiler is sturdier than ever before. The 418's pump assembly and heavy-duty reservoir are designed to increase productivity.

- 50% more oil per stroke than other hand-held oilers for longer die life
- Die cast, heavy-duty body with swivel nozzle with no exposed parts for longer life
- Includes 1 gallon thread cutting oil, reservoir with removable chip tray, and 54" hose



Item #
RI10883

RIDGE TOOL CO.

Power Drive
Model No. 600

- Capacity 1/8" - 1-1/4" pipe; designed for Ridgid 11R die heads
- Ideal for on-site applications such as gas line pipe installation
- Capacity: 1/8"-1-1/4" pipe
- Die Heads Included: 1/2, 3/4, 1, 1-1/4 (type 11R)



Item #
RI36912

RIDGE TOOL CO.

Power Drive For
Pipe Threaders
Model 700

- Heavy-duty hand held power drive
- Capacity: 1/8"-2" pipe; designed for Ridgid® 12R die heads - Other Ridgid® die heads (OOR, OORB, 11R) using adapters, threading 2-1/2" through 6" with 141/161 geared threaders
- Rod Threading Cap.: 1/4"-1
- Max. Geared Threader Cap.: 6"



Item #
RI41935

RIDGE TOOL CO.

Support Arm

For Use With Power Drives

- Use the support arm to resist the torque developed when threading larger pipe

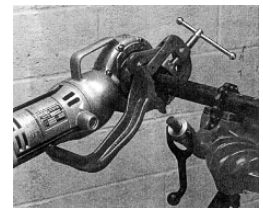

Item #	Model No.	Desc.
RI42600	770	Adapter for OO-R and OO-RB
RI42620	774	Square Drive Adapter - 15/16
RI42625	775	Support Arm For No. 700
RI42950	B-171-X	Metal Carrying Case

RIDGID

RIDGE TOOL CO.
Power Threading Components

Components Only
No. 300

Item #	Desc.	Location
RI42370	No. 360 Cutter	B
RI42365	No 341 Reamer	C
RI68815	No. 311 Carriage With Lever	D
RI42360	No 1206 Stand	E
RI41855	300 Power Drive Only	G

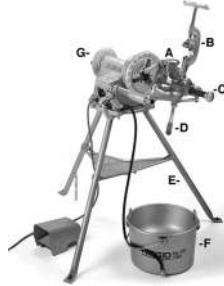

RIDGE TOOL CO.
Power Threading Unit
Power Drive Complete
No. 300

Standard Equipment:

- Model 300 Power Drive with foot switch
- No. 811A universal, quick-opening die head
- 1/2" - 3/4" universal alloy die set
- No. 360 Cutter: Capacity: 1/8" - 2" pipe, 1/4" - 7/8" rod with F-3 wheel, 5/16" - 1" with E-1032 cutter wheel
- No. 341 Reamer: Positive-locking, 5-flute cone, right-hand 1/8" - 2"; special E863 RH/LH combination reamer cone available
- No. 311 Carriage with lever
- No. 1206 Stand
- No. 1452 Clip-on tool tray
- No. 418 Oiler with 1 gallon of premium thread cutting oil
- No. 32 Transporter



Item #	Spindle Speed RPM	Pipe Threading Capacity (in.)
RI15682	38	1/8-2
RI15722	57	1/8-1 1/4

RIDGE TOOL CO.
Universal Stands

- Fits models 535 and 18221 power threaders

Item #	Stand Includes	Model No.
RI92462	Tray	150A
RI92467	Cabinet	200A



RIDGE TOOL CO.
Automatic Threading Machine

Machine Only
Model 535A

The model 535A maintains the ruggedness of the industry workhorse while adding features that make the threading operation more productive. A large chip tray and oil reservoir make the 535A ideal for longer uninterrupted threading. The 535A is designed around maximum uptime with the upgrades that matter most to the pipe working professional.



- Automatic chuck
- 3-speed (16/46/58 RPM) transmission
- Large 1.75 gallon oil reservoir
- High clearance carriage
- Can be used with geared threader Model 141
- Uses Model 816/817 semi-automatic, Model 815A self opening or Model 811A quick-opening die heads
- Pipe Capacity: 1/8" - 2", 2-1/2" - 4" with 141 geared threader
- Bolt Capacity: 5/16"-2"

Item #
RI91142

RIDGE TOOL CO.
Die Head Only

Universal Quick - Opening
No. 811A

- Thread direction: RH
- Oil Thru Head: Yes
- Pipe Capacity: 1/8"-2"
- Bolt Capacity: 1/4"-2"
- Quick-Opening - Manually flip throwout lever to retract dies when thread length is cut



Item # Desc.
RI97065 811A Universal Die Head Only

RIDGE TOOL CO.
Die Head Only

Self-Opening
No. 815A

- Self-opening die head
- Trigger foot automatically retracts dies when thread length is cut
- Cutting oil through the head
- Pipe capacity: 1/8" to 2"
- Bolt capacity: 1/4" to 2"



Item #
RI97075



RIDGID

RIDGE TOOL CO.
Die Head Only

Universal Quick-Set

- Semi-automatic dieheads retract automatically on hitting handle
- Right-hand thread direction
- Furnishes cutting oil through the head



Item #	Model No.	Pipe Cap. (in.)
RI84532	816	1/8"-3/4"
RI84537	817	1-2"

RIDGE TOOL CO.
Threading Machine

Machine Only
Model No. 535

Features:

- Automatic through die head oiling
- Speed chuck with rocker-action jaws centers and grips workpiece instantly
- Can be used with geared threaders
- Self priming oil pump
- 5-flute cone, RH, 1/8"-2" reamers

Capacity:

- Pipe - 1/8"-2"
- 2-1/2"-4", 4"-6" with 141 and 161 geared threaders
- Bolt - 1/4"-2"

Standard Equipment: Model 535 threading machine with foot switch, 1-No. 811-A universal quick opening die head, 1-No. 341 reamer, 1-No. 820 cutter, 1 set 1/2"-3/4" universal alloy dies, 1 set 1"-2" universal alloy dies, 1 gallon Nu-Clear oil, 4 hex wrenches, 1 spare E-1032 cutter wheel, 1 tube lubricating grease



Item #
RI96497

RIDGE TOOL CO.
Power Threading Machine Accessories

Machine Stand Adapter Bracket
Model 535

Item #	Desc.
RI58007	Machine stand adaptor bracket for 535's built before 1996.*



RIDGE TOOL CO.
Threading Machines

Oil-Less
Model 1210

• Pipe: 1/2" - 1" (12-25mm)
The Ridgid® model 1210 oil-less threading machine offers an unbeatable combination of portability and clean operation in a rugged package designed for job-site threading. With the model 1210, you can thread virtually anywhere: in basements, on rooftops, even in finished rooms! Thread where you install and save time and effort.



- Self-contained with all the tools needed to cut, ream and thread
- Cutter: Model 354
- Reamer: Model 334

Item #	Desc.	Model No.
RI67872	1/2 in. - 1 in. NPT, 115V, 25 - 60 Hz	1210

RIDGE TOOL CO.
Threading Machine

1/2" to 1-1/2" NPT
Model No. 1215

- Through die head oiling
- Standard Equipment:
 - 1 - No. 811A Quick Opening Die Head
 - 1 - Set 1/2"-3/4" Universal alloy NPT dies
 - 1 - Set 1" - 1-1/2" Universal alloy NPT dies
 - 1 - No. 344 five fluted reamer 1/4" - 1-1/2"
 - 1 - No. 732 Cutter with cutter wheel
 - 1 - Gallon Nu-Clear oil



Item #
RI61142

RIDGE TOOL CO.
Geared Threader Accessories

No. 840A universal drive shaft:

- A telescoping (41" to 50") drive shaft for operation of nos. 141 and 161 geared threaders with threading machines

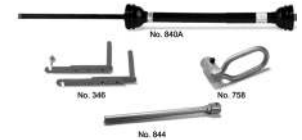

Geared threader operation:

- The nos. 141 and 161 geared threaders, in conjunction with these accessories, allow power drives and threading machines to thread up to 4" and 6" pipe

Item #	Desc.
RI61122	Universal Drive Shaft

RIDGID

RIDGE TOOL CO.

Power Threading Unit With Folding Wheel Stand No. 300 Compact Kit



Model 300 compact threading machine capacity:

- Pipe: 1/8"-2"
- Bolt: 1/4"-2"
- Lightweight, portable design; fast transport and set-up
- Self-contained oil system
- Hammer-type chuck with replaceable, rocker-action jaw inserts

Standard Equipment:

- Model 300 compact threading machine
- 1-No. 811A quick-opening die head
- 1-No. 344 reamer
- 1-No. 360 cutter with E-1032 cutter wheel
- 1 Set 1/2"-3/4" alloy universal dies
- Set 1"-2" alloy universal dies
- 1 gallon Nu-Clear threading cutting oil
- Includes Model 250 folding wheel stand

Item #

RI67182

RIDGE TOOL CO.

Power Threading Unit 1/2 - 4" NPT, 120V 60Hz Model 1224



The 1224 threads a wide range of pipe including black, galvanized and plastic coated pipe, together with stainless steel, IMC and heavy-wall conduit, as well as rod up to 30 Rockwell C.

Capacity:

- Pipe: 1/4"-4"; 4"-6" with 161 geared threader; Bolt: 1/4"-2"

Features:

- Threads 1/4"-2" pipe and 2-1/2"; 1/4" - 2" universal die head; 2-1/2" - 4" receding die heads allows cutting of tapered or straight NPT/NPSM; constant and proper lubrication of dies and work-piece with through-head oiling

Technical specifications:

- 1 No. 714 (914) 2-1/2" - 4" receding self-opening die head
- 1 No. 711 (911) 1/4" - 2" universal self-opening die head
- 1 set 1/2" - 3/4" universal alloy dies
- 1 set 1" - 2" universal alloy dies
- 1 set 2-1/2" - 4" 1224 high speed dies
- 1 gallon Nu-Clear oil
- 3 hex keys; 1 spare F-229 cutter wheel
- 1-3/4" combination wrench
- 1 tool box
- 1 No. 744 reamer
- 1 No. 764 cutter

Item #

RI26092

RIDGE TOOL CO.

Die Heads

For Model No. 1224

Note: Die heads do not include dies. All die heads are through-head oiling.

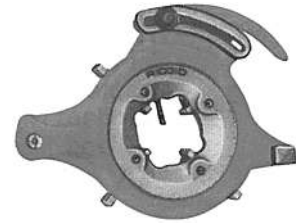

Item #	Model No.	Desc.	Capacity (in.)
RI26132	711	Universal Self-Opening R.H., NPT	1/4 - 2
RI26152	714	Receding Self-Opening R.H., NPT	2 1/2 - 4

RIDGE TOOL CO.

Pipe Die Set

For Model 1224 Threader NPT High Speed

- For Model 1224 Threader



Item #	Desc.	Capacity (in.)
RI26192	1224 H.S. Dies NPT	2 1/2 - 4
RI33057	1224 H.S. Dies NPT for Stainless Steel	2 1/2 - 4

RIDGE TOOL CO.

Pipe Die Set

National Pipe Taper

- Listed below are pipe dies for use in Universal Die Heads
- Use With 504A, 711, 713, 811A, 815A, 816, 817 and 842



Item # Nominal Pipe Size-Threads per Inch (in.)

Alloy RH

RI47740	1/4-3/8-18
RI47745	1/2-3/4-14
RI47750	1-2-11 1/2

High Speed RH

RI47755	1/8-27
RI47760	1/4-3/8-18
RI47765	1/2-3/4-14
RI47770	1-2-11 1/2

H. S. For Stainless Steel RH

RI47780	1/4-3/8-18
RI47785	1/2-3/4-14
RI47790	1-2-11 1/2



RIDGID

RIDGE TOOL CO.

Bolt Dies

- Bolt dies for universal die heads (nos. 504A, 711, 811A, 815A, 816, 817 and 911 die heads)
- (UNC) RH high-speed



Item #	Rod Size- TPI (in.)
RI48225	3/8 - 16
RI48235	1/2 - 13
RI48245	5/8 - 11
RI48250	3/4 - 10
RI48255	7/8 - 9
RI48260	1 - 8
RI48270	1 1/4 - 7

RIDGE TOOL CO.

Nipple Chuck Kits

- Holds short or close nipples for threading
- Holds studs for threading
- For use with 300 power drive, 300 compact, 535 and 1822 (with adapter kit) and 1224 threading machines
- Standard nipple chuck includes insert and 5 adapters: 1/2", 3/4", 1", 1-1/4" and 1-1/2" (nipple chuck body serves as 2" adapter)



Item #	Model No.	Desc.
RI51005	819	NPT Nipple Chuck 1/2 in. - 2 in.

RIDGE TOOL CO.

Power Driver Roll Groover

Model No. 916

- Ridgid Model 916 Roll Groover is the most durable and mechanically efficient lightweight portable unit available
- Cam-type feed actuation-only minimum effort required by operator
- Capacity:
 - 1-1/4"-6" Sch. 10 steel
 - 1-1/4"-3" Sch. 40 steel



Standard Equipment:

- One (1) 1-1/4" - 6" Roll groove set for steel

Item #	Desc.
RI45007	Roll Groover for 300 Power Drive

RIDGE TOOL CO.

Grooving Die Set

To cut groove pipe for mechanical type couplings, consult chart for sizes and die head information

- Pipe Size: 1" - 2"
- Used in Die Head: Universal

Item #
RI50985



RIDGE TOOL CO.

Combo Roll Groover

Model No. 975

The new, Model 975 Combo Roll Groover is two tools in one! Like other Ridgid® groovers, the 975 mounts on the Ridgid® 300 Power Drive for machine grooving jobs, but it is also designed to manually groove in-place pipe.



- Pipe Capacity: 1-1/4" - 6" Schedule 10 and Schedule 40 Steel, Aluminum, and PVC Pipe; 1-1/4" - 6" Schedule 10, 11/4" - 2" Schedule 40 Stainless Steel Pipe, 1-1/2" - 4" Schedule 80 PVC Pipe; With Roll Change 2" - 8" Copper Tube (Type K, L, M, and DWV)

Item #
RI25638

RIDGE TOOL CO.

Hydraulic Roll Groover

Model No. 918

The Ridgid model 918 hydraulic roll groover features a powerful 15 ton hydraulic ram in a compact, easy to transport unit. With one man set-up and operation, the 918 is the ideal groover for job-site requirements. The 918 adapts quickly to Ridgid 300 power drive, 535, 1822, or 1224 threading machines. The 918 is capable of grooving up to 12" schedule 10 and 8" schedule 40 standard wall pipes. Roll set changeout is accomplished in seconds.



Specifications:

- Capacity: 1" - 12" schedule 10 steel
- 1"-8" schedule 40 steel
- 2"-6" cooper (types K, L, M, DWV)
- 2-1/2" - 6" schedule 80 PVC

Standard equipment:

- One (1) 2" - 6" schedule 10/40 roll set
- One (1) 8" - 12" schedule 10(8" schedule 40) roll set

Item #	Desc.
RI48297	918 Roll Groover W/300 Power Drive Mount Kit

RIDGID

RIDGE TOOL CO.

Roll Grooving Machines Model No. 918-I

The Ridgid® model 918-I is capable of grooving 1" to 8" schedule 40 and 1" to 12" schedule 10 pipe faster than any roll grooving machine in its class.

Specifications:

- 2"-6" copper (types K, L, M, DMV)
- 2-1/2" - 6" schedule 80 PVC

Standard equipment:

- One (1) 2" - 6" schedule 10/40 roll set
- One (1) 8" - 12" schedule 10 (8" schedule 40) roll set
- One (1) tools for roll set changeout
- One (1) carry case for roll sets
- One (1) heavy-duty wheel stand with tray
- One (1) foot switch
- One (1) 1" - 12" stabilizer for grooving nipples



Item #	Desc.
RI64977	Roll Grooving Machine Complete, 115V

RIDGE TOOL CO.

Power Hole Cutting Tool

1/4" to 3"

Model HC-300

The Ridgid® Model HC-300 hole cutting tool is designed to cut holes up to 3" diameter into steel pipe.

- High speed; with a powerful 1.2 hp, 11 amp- motor, the Model HC-300 delivers 360 rpm to quickly bore holes while optimizing hole saw life
- Specifications: 1/16" - 1/2" chuck size; 1-1/2" - 8" pipe range



Item #
RI76777

RIDGE TOOL CO.

4-3/4" Hole Cutting Tool

Model HC-450

The Ridgid® Model HC450 is engineered for continuous 1/4" to 4-3/4" hole cutting in and up to 8" diameter steel unpressurized pipe.

- 13 amp 1.2 HP worm-gear driven motor delivers unmatched hole cutting power for schedule 10, 40 and 80 pipe
- Quickly mounts onto 1-1/4" to 8" diameter pipe
- Only 11-1/2" high for low clearance jobs
- Chuck accommodates 1/8" to 5/8" arbors"



Item #	Chuck Size (in.)	Hole Cutting Capacity: (in.)
RI57592	5/8	up to 4-3/4

RIDGE TOOL CO.

Combination Bench & Pipe Vise

Forged Steel
F-Series

- The F-Series vises are constructed of 75,000 PSI tensile strength forged steel
- All steel, drop forged construction
- Steel handle with rubber anti-pinch rings
- Standard fixed pipe jaws
- Large, hardened anvil
- Forged steel swivel base with dual draw down bolts



Item #	Size Pipe
RI66987	4 1/2
RI66992	5
RI66997	6

RIDGE TOOL CO.

Fiberglass Folding Rules

- Precision made of flexible heavy-duty fiberglass with embedded, easy-to-read boldface figures and graduations with red 16" stud marks and positive locking joints
- 6 ft. inside flat reading
- Width: 5/8 in.
- Length: 6 ft.

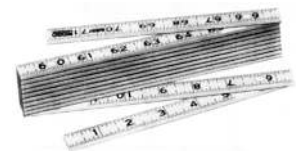

Item #
RI73370

RIDGE TOOL CO.

Pliers

Water Pump

- Professional quality tools, precision crafted for ultimate balance, high strength and exacting performance
- Forged and heat-treated for extended life and durability



Item #	Desc.	Length (in.)
RI80475	Water Pump Pliers (2 in. Capacity)	10

RIDGE TOOL CO.

Screw Extractor Set

Model 10

No. 10 set contains 20 precision tools – one each of Extractor Nos. 1 to 5 inclusive with turnuts, drill Nos. 1 to 5 inclusive, and drill guides Nos. 921 to 1821 inclusive. Pre-formed plastic box provides convenient storage.

- Capacity: 1/4" to 1/2"



Item #
RI35585



RIDGID

RIDGE TOOL CO.
Plumbing Bender

300 Series

- Designed to bend copper tubing to a maximum of 180°
- Offset cushion grip handles and a 90° start angle, together with a specially engineered plastic shoe, combine to ease bending effort
- 300 series lever benders form smooth bends in types K & L soft (annealed) copper tubing
- Tube Size 5/8"
- Bend Radius: 2-1/4"



Item #

RI36962

RIDGE TOOL CO.
Instrument Bender

400 Series

- 400 series instrument benders combine accuracy with easy operation
- Offset cushion grip handles eliminate knuckle cracking when forming 180° bends
- A 90° start angle and unique oil-absorbing shoe minimize bending effort while forming accurate bends in copper, steel and stainless steel tubing



Item #	Model No.	Capacity Tube Size (Actual O.D.) (in.)	Capacity Bend Radius (in.)
RI36122	404	1/4	5/8
RI36097	406	3/8	15/16
RI36132	408	1/2	1 1/2

RIDGE TOOL CO.
Tri-Bender

Model No. 456

The 456 Tri-Bender is designed to easily bend three different sizes of soft tubing: 1/4", 5/16" and 3/8" with the same tool. Ideal for plumbing and HVAC applications. A 90° start angle minimizes effort required to form a bend. Handy reference marks indicate the angle for quick bends through 90°.

- Capacity (in.): 1/4, 5/16, 3/8



Item #

RI44852

RIDGE TOOL CO.
Tube Bender



Spring Type

- Fast, free-form bending of soft copper and aluminum tube

Item #	Model #	Length (in.)	Tube O.D. (in.)
RI35245	D-1375	10	1/4
RI35255	D-1377	10	3/8
RI35265	D-1379	12	1/2
RI35275	D-1381	12	3/4
RI35280	D-1382	12	7/8

RIDGE TOOL CO.
Ratchet Flaring Tool

Model No. 458R

- Flaring tool is recommended for soft material such as aluminum and soft copper, flare steel, stainless steel, hard copper and brass thru wall thickness of .035 inches
- 45 deg. SAE flares, Sizes: 1/8, 3/16, 1/4, 5/16, 3/8, 1/2, 5/8, 3/4 in.



Item #

RI83037

RIDGE TOOL CO.
Hammer-Type Flaring Tools

- Made of high-grade hardened steel, these tools have a long nose guide that centers tools for smooth, 45° uniform flares



Item #	Model No.	Water Tube Size (in.)
RI41315	E-37	3/8
RI41320	E-45	1/2
RI41330	E-47	3/4
RI41335	E-52	1

RIDGE TOOL CO.
115V Electric Solder Gun
Model RT-175 Professional

- For 1/4" to 3" tube (soft soldering)
- Flameless soldering - safe, easy-to-use
- Twelve feet of cable
- Fully contained in metal carrying case



Item #

RI62862

RIDGID

RIDGE TOOL CO.

Pipe Freeze Tool Kit

Model SF-2500 - SuperFreeze™

- SuperFreeze® Pipe Freezing Tool Avoids the Cost and Inconvenience of a System Shutdown and Purge.
- The SuperFreeze Pipe Freezer is an easy-to-use pipe freezing unit that allows the contractor to keep water systems operating while making repairs. The Ridgid SF-2500 is a mini-refrigeration unit that circulates self-contained refrigerant to its aluminum freeze heads. This forms an ice plug in as little as 6 minutes in 1/2" copper tube and can be used with up to 2-1/2" tube or 2" pipe. Once the pipe is plugged, repairs can be made while the ice plug is maintained by the unit. Now includes a bottle of specially formulated freeze gel to speed freezing. Apply the gel to freeze heads before placing on pipe.
- Approved by UL to CSA and UL standards
- Capacity: Copper Tube: 1/2" - 2 1/2"; Steel Pipe: 1/2" - 2"
- Compressor: 115V, 60 Hz, 4.3A
- Refrigerant: R-507 (14.2 oz. charge)
- Hose Length: 8.5 ft. (17 ft. span)
- Dimensions: L = 21" W = 10.5" H = 13"



Item #

RI68967

RIDGE TOOL CO.

Press Tool

Model RP 210-B

The Model RP 210-B is a fast and reliable way to join copper, stainless steel and PEX fittings. It is 2 inches shorter and 25% lighter than our previous compact tool for more pressing with less fatigue. It's 270° rotating swivel jaw helps users get into tight places. With a 5,400 pounds hydraulic ram output, the Model 210-B has more capacity than any compact press tool available. As part of this new design, the Model 210-B service interval has been extended to 32,000 cycles.



Specifications:

- Capacity: 1/2" to 1-1/4" for copper and stainless, 3/8" to 1-1/2" for PEX
- Compatible with all Ridgid® compact series pressing attachments
- 270° barrel/jaw swivel
- Battery: 18V Li-Ion, 1.1 Ah
- Hydraulic Ram Output: 5,400 lbs.
- Weight: 6.4 lbs. with battery
- Operating Temperature Range: 15°F - 122°F
- Approximate Cycle Time: 5 seconds
- Standard Kit Includes: RP 210-B Press Tool, 2 Batteries, Battery Charger and Carrying Case

Item #

Desc.

RI31028 RP 210-B Battery Press Tool Kit w/ProPress Jaws (1/2" - 1 1/4")

RIDGE TOOL CO.

Pipe Thawers

For fast thawing of frozen metal pipes 1/2" through 1-1/2" (12-36 mm).

KT-200 pipe thawing unit provides continuous heating to quickly thaw 1/2" to 1-1/2" frozen metal pipes. Simply attach the clamps to the metal pipe on each side of the frozen section and the pipe is thawed within minutes.



- KT-200 can be used on 4' to 150' lengths of pipe; the KT-200'S amp meter allows the user to select the proper output level for maximum current draw and minimum thawing time
- Powerful: Units operate on a standard 115V, 15 amp outlet; the KT-200 produces 250-400 amps of thawing power

Item #

Model No.

Desc.

RI62747 KT-200 Pipe Thawer W/2-25 (ft.) 1/10 Cables

RIDGE TOOL CO.

Corded Press Tool

Model RP 330-C

With all the same features, functionality and durability of the battery-powered version, the RP 330-C press tool is the workhorse of the job site. At nearly one-half the weight of the previous CT400 unit, this is our lightest corded press tool.



Specifications:

- 270° Barrel/Jaw Swivel
- Hydraulic Ram Output: 7,200 lbs.
- Operating Temperature Range: 15°F to 122°F
- Approximate Cycle Time: 5 Seconds
- Standard Kit Includes: RP 330-C Press Tool and Carrying Case
- Compatible with all Ridgid Standard Series Pressing Attachments
- For use with Copper, Stainless Steel and PEX Tubing
- Approved by UL to UL and CSA Standards

Item #

Desc.

Capacity (in.)

Weight (lbs.)

RI27938 Kit without Jaw Sets 1/2 - 4 9

RIDGE TOOL CO.

ProPress Tool

Cordless

Model 100-B

- It's Fast! Tool completes connection in seconds, cutting total installation time in half versus soldering
- Reliable, watertight connections every time
- Innovative, Compact Tool and Jaw Design fits into tight spots
- New Compact Series Jaws are 40% lighter and 33% smaller than traditional Standard Series Jaws
- 90° Swivel Barrel allows you to work around obstructions
- Capacity to handle up to 1" copper and 1-1/2" PEX tubing
- 14.4V (2.6Ah) Ni-MH Battery allows 30% more work per charge versus NiCad
- Ram Force: 5,400 lbs. (24kN)
- Includes: Pressing tool, 2 batteries, battery charger and carrying case



Item #

Desc.

RI16953 1/2" to 1" Jaw Sets for ProPress (copper)



RIDGID

RIDGE TOOL CO.
ProPress Tool
Cordless
RP 330-B



For convenience and portability, the RP 330-B is the logical choice. Featuring a barrel that rotates 270 degrees and a longer service interval, the RP 330-B is designed to handle your toughest construction projects. Powered by a 18V Lithium-Ion Battery, the RP 330-B offers more presses per battery charge than ever before.

- Capacity: 1/2" – 4"
- 270° Barrel/Jaw Swivel
- Battery: 18V Li-Ion
- Hydraulic Ram Output: 7,200 lbs. (32kN)

Item #	Desc.
RI27913	Battery Pressing Tool w/Batteries and Case (No Jaws)
RI27923	Battery Pressing Tool w/ProPress 1/2" – 2" Jaws

RIDGE TOOL CO.

Standard Series Rings

ProPress® XL-C™



- Patented Ring Design to make pressed connections for 2-1/2" - 4" copper tube
- New XL-C Rings and V2 Actuator Jaw include patented swiveling feature that allows the tool to connect to the ring at any angle relative to the tubing, allowing greater access in tight spaces
- Designed in conjunction with the ProPress XL-C fittings, ensuring total system compatibility
- Compatible Only with Ridgid® Standard Series pressing tools
- V2 Actuator Jaw features new jaw identification clips, for fast, easy identification of the appropriate pressing jaw
- Includes: Standard Series XL-C Ring Kit Includes: One V2 Actuator, 2-1/2" Ring, 3" Ring, 4" Ring, Tube Insertion Depth Marking Gauge, Carrying Case, and Operator's Manual

Item #
RI20483

RIDGE TOOL CO.

Press Rings

C1 Kit



Rings for ProPress® permit access in tighter spaces and serve as an excellent complement to your Ridgid® jaw sets. The swivel actuator allows a press tool to be placed +/-90 degrees to the tube being pressed!

- Designed in conjunction with the ProPress® System Fittings, ensuring total system compatibility
- C1 Compact Kits are designed for Ridgid® Compact Press Tools
- Standard Kit includes: Press Rings, Actuator and Carrying Case
- Capacity: 1/2" to 1-1/4" Ring

Item #
RI28043

RIDGE TOOL CO.

Inspection Camera

Seesnake® Micro™



Specifications:

- Display: 2.4" Color LCD (160 x 234 resolution)
- Camera Diameter: 0.37" or 0.7" aluminum
- Lighting: 1 or 2 Adjustable LEDs
- Cable Reach: 3' (expandable to 30' w/optional extensions)
- Waterproof: Camera & Cable to 10' (when properly assembled)
- Power Source: 4 AA Batteries (6 hrs. of continuous run-time)
- Attachments: Mirror, Hook & Magnet

Item #	Desc.
RI31118	SeeSnake micro Inspection Camera 17 mm
RI26663	Imager Head & Cable 17 mm
RI26668	Accessory Pack (Mirror, Hook, Magnet) 17 mm
RI30068	Imager Head and Cable 9.5 mm

RIDGE TOOL CO.

Digital Inspection Camera

MicroExplorer™



- Display: 3.5" Color LCD (320 x 240 resolution)
- Image Capture: JPG Images (1280 x 1024); AVI Video (320 x 240)
- Recording Medium: Internal Memory or SD Card
- Additional Ports: USB and SD card
- Image Controls: Pan, Zoom, Self Leveling, Low Light Vision
- Lighting: 4 Fully Adjustable LEDs
- Camera Diameter: 0.7" (17 mm)
- Cable Reach: 3' (expandable to 30' w/optional extensions)
- Waterproof: Camera & Cable to 10' (when properly assembled)

Item #
RI30063

RIDGE TOOL CO.

Camera Cable

Extension Accessories



3' or 6'

- Combine to see objects up to 30' away
- Compatible with SeeSnake micro or microEXPLORER

Item #	Desc.
RI31128	Universal 3' Cable Extension
RI31133	Universal 6' Cable Extension

RIDGID

RIDGE TOOL CO.
Compact Video Inspection System
Seesnake®

The SeeSnake Compact System offers fast setup for quick inspections. Its ultra portability makes this system an excellent complement to your SeeSnake Plus.

Standard Equipment:

Power Source:

- Battery port for use with optional 18V battery
- AC/DC operation

MINIPak Monitor System:

- High-resolution monitor
- Push button controls for sonde, power, lights, flipscreen and zeroing the counter
- Splash-resistant case with built in sunshade

Video In/Out jack

Camera System:

- Scratch-resistant, debris-shedding, flush-mounted sapphire lens
- Integrated transmitter
- Durable stainless steel camera head assembly and tapered spring assembly

Reel:

- 100' of push cable
- Debris-capturing, rotating drum with mercury-free slip ring
- Counter to display distance on monitor in feet and inches



Item #	Desc.
--------	-------

RI32903 Color Compact System w/Battery & Charger, 115V

RIDGE TOOL CO.
Utility Line Locator
SeekTech SR-20

- Proximity Signal Minimizes depth over target and maximizes relative signal strength to guide you closer to the target independent of the current flow
- Mapping Display Virtually maps the utility to help guide you down the line. Shows signal distortion and line turns in real time
- Continual Depth Increase productivity by showing depth changes in real time
- Guidance Arrows Guides the operator to target line by minimizing signal gradient
- Active Line Trace Frequencies: 128Hz, 1kHz, 8kHz, 33kHz
- Sound Frequencies: 16Hz, 512Hz, 33kHz
- Passive Power Trace: 50Hz, 60Hz
- Passive Radio Trace: <4kHz, 4kHz-15kHz, 15kHz-38kHz



Item #

RI21893

RIDGE TOOL CO.
Toilet Auger
No. K-3

High-quality tool in 3' length provides fast and safe clearing of closet obstructions.

Features Include:

- Negotiate water-conserving closets
- New, durable, kink-resistant, 1/2" compression-wrapped Inner Core cable



Item #	Model No.	Desc.
RI59787	K-3	3' Toilet Auger w/Bulb Head

RIDGE TOOL CO.
Drain Cleaner

Sink Machine
Model K-39 - 3/4" to 2-1/2"
Capacity

- Excellent for small line cleaning; opens clogged lavatory, sink lines, urinals, and tub/shower drains - 5/16" cables best for 3/4" to 1-1/2" lines
- Power unit rotates cable 0-500 RPM's
- Two piece twist lock canister with interchangeable inner drum
- New inner drum prevents water leaks and greatly reduces cable flip over
- Drum capacity: 50' of 5/16" or 35' of 3/8"
- K-39 (68057) - Includes: C-11C, 5/16" inner core cable w/inner drum



Item #
RI68057

RIDGE TOOL CO.
Drain Cleaner

Sink Machine
K-40AF

The K-40 Dual Feed Sink Machine provides the professional with a powerful yet compact machine for cleaning small secondary drain lines from 3/4" to 2-1/2" (19 mm - 64 mm). When used with the dual feed your hands literally never need to touch the cable, and there is no mess.

- Dual Feed – Advanced two way feed keeps hands off cable, advances and retrieves with push of a lever.
- Dual Position – The K-40 sits flat on the floor, countertop, or tips onto its back for easy access to elevated drains.
- Two-piece "twist lock" drum housing allows easy access to the inner drum and cable and will not dent or corrode.
- Includes: Autofeed, Guide Hose, Mounting Bracket, C-131C SB, 5/16" x 35' (10.7m) Speed Bump Cable w/Inner Drum



Item #
RI71722



RIDGID

RIDGE TOOL CO.
Drain Cleaner Accessories

Cables & Gloves

Listed below are replacement cables and gloves for Ridgid drain cleaners:

- 62225- 5/16" x 25' cable with bulb auger fits K50
- 62235- 25' with drop head auger fits K50
- 62260 - 35' with male coupling fits K50
- 62270 - 7-1/2' all purpose wind fits K50, K 75, K60SP
- 62280 - 15' standard all purpose wind 3/8" pitch, good for 4" traps, 3 to 8" lines fits K1500
- 59295 right-hand mitt
- 59205 left-hand mitt



Item #	Fits	Desc.
RI62225		

Cable

Glove

RI62235		
RI62245	C-4	25' with Male Coupling
RI62250	C-5	35' with Bulb Auger
RI62260		
RI62270		
RI59295		
RI59205		

RIDGE TOOL CO.
Drain Cleaner Cable

Fits K-380 Machines

- Cable size: 3/8" x75'
- Fits K-380, K-400 & K-3800 Machines

Item #
RI87582



RIDGE TOOL CO.
Drain Cleaner Cable

Fits K-3800 Drain Cleaner

3/8" I.C. Cable for Standard Drum

Item #	Length (ft.)
RI37842	50
RI37847	75



RIDGE TOOL CO.
Drain Cleaner

For 3/4" to 3" Drain Lines Model K-3800 Machine Kit

A powerful, easy to transport, versatile machine for cleaning indoor drains. Requires minimal set-up to clean sink lines, floor drains, roof vents.



- Rugged, corrosion-resistant molded cable drum won't dent or rust' the drum tilt-adjusts for proper cable feed angle, inner-drum guards against cable flip-over
- K-3800 Description: C-32, 3/8" x 75' Cable, T-202 Bulb auger, T-205 "C" Cutter, T-211 Spade cutter, A-13 Pin key, pair of gloves

Item #
RI53117

RIDGE TOOL CO.
Drain Cleaner Accessories

Listed below are accessories for Ridgid drain cleaners:

- 59225 - Pin key for 1/2 inch cable fits K375, K3800, K605SP, K75, K1500
- 59230 - Pin key for 3/8 inch cable fits K375, K3800, K60SP, K75
- 62850 - Straight auger fits K375, K3800
- 62855 - Funnel auger fits K375, K3800
- 62990 - 5" long straight auger fits K375, K50, K38, K3800
- 62995 - 1-1/8" O.D. bulb auger fits K375, K50, K38, K3800
- 63000 - 7/8" O.D. bulb auger fits K50
- 63005- 1-3/8" C-Cutter fits K50, K38, K3800
- 63010 - 3" long funnel auger fits K50, K38, K3800
- 63065 - 4" drop head fits K50, K3800, K38

NO IMAGE AVAILABLE

Item #
RI62990

Fits C-44 and C-45

Fits C-31, C-32 and C-33

RI63065
RI63005
RI59225
RI59470

RIDGE TOOL CO.
Inner Core Cables

Model C-24

Inner Core (IC) cables provide good flexibility and more cleaning power to the cable end.

- Length: 100'



Item #
EC43647

RIDGID

RIDGE TOOL CO.

Drain Cleaner

For 4" to 10" Drain/Sewer Lines

Model K-750 Power Feed Kit

- Powerful, self-contained machine ideal for lateral lines. Easy-to-transport, minimal set-up - attach a tool and go
- Powerfeed advances, retrieves cable automatically, up to 20' per minute
- Versatile powerfeed adjusts for either 5/8" or 3/4" cable with a twist of a screwdriver
- Recommend 5/8" cable for 3" to 6" drain lines up to 200'
- Recommend 3/4" cable for 4" to 10" drain lines up to 200'
- Drum holds 100' of 3/4" or 125' of 5/8" cable and is designed for quick, easy removal
- Kit includes: Machine with one pair of gloves, powerfeed, standard 3/4" tool set, and C-75, 75'x3/4" cable
- Tool set includes: T-406 spear blade cutter, T-407 retrieving auger, T-411 2" cutter, T-413 3" cutter, T-414 4" cutter



Item #

RI42002

RIDGE TOOL CO.

Drain Cleaner Cable

3/4" x 100' I.C. Cable

Fits K-750 & K-7500 Machines

- Length: 100'
- Size/type: 3/4" (20 mm) w/hollow core
- Typical applications: drain Lines 4" to 6" -main lines including laterals
- Hollow core cable is lighter in weight and more flexible; helps operator negotiate difficult traps and bends in large lines



Item #

RI41697

RIDGE TOOL CO.

Drain Cleaner

For 3" to 10" Drain Lines

Model K-7500 Power Feed Kit

The performance, cable control, durability and maneuverability demanded by professional users. Ideal for any tough job, such as roots - up to 250'

- Recommend 5/8" cable for 3" to 6" drain lines up to 250'
- Recommend 3/4" cable for 4" to 10" drain lines up to 250'
- Description: Standard accessories and 3/4" x 100' inner core cable



Item #

RI60052

RIDGE TOOL CO.

Drum Machine

Model K-375R

- The K-375R makes quick work for cleaning drains from 2" to 4"; a variety of cutting tools with quick connect couplers make it easy to match the right tool for the right job
 - Ideal for clearing non-root blockages in floor and gutter drains, interior laterals and vent pipes; removes grease, debris, and lint
- Features:



- Clear access to drum allows immediate view of cable for inspection plus easier and faster cleaning of drum and cable
- Patented Cable Control System slows the drum, should cable or blade become completely lodged in blockage
- New integral-wound, solid core cable is tough and kink resistant. (1/2" x 50')

Typical Applications:

- Floor Drains, Vent Pipes, Stack Lines, Gutter Drains

Specifications:

- Motor: 1/3 HP, 115V, 60Hz Reversible Induction Motor
- 190 RPM
- Air Activated Foot Switch
- Quick Disconnect Drum
- Weight: 73 lbs.
- New Torque Limiter Feature
- NOTE! Should Not Be Used to Cut Roots.
- 1/2" Open Cage Drum Machine w/1/2" x 50' IW Solid Core Cable; T-260 Tool Set includes: T-202 1 1/8" Bulb Auger, T-205 "C" Cutter, T-211 Spade Cutter and Pin Key; Gloves

Item #

RI83292

RIDGE TOOL CO.

Drain Cleaner

Water Jetter

Model KJ-1350-C

These jetters propel a highly flexible hose through 1 1/4" to 4" lines - blasting through sludge, soap, and grease blockages. As you pull the hose back, it power scrubs the line, flushing debris away and restoring drain lines to their free flowing capacity.



- Easy to use: Thrust propels the hose down the line. You simply guide the hose into the drain
- KJ-1350-C contains: Standard Jetter with Pulse, H-21, H-22 and H-24 1/8" NPT Nozzles, 100'x 1/4" Sink Trap Hose, Nylon Storage Bag, Nozzle Cleaning Tool and an H-10 Cart

Item #

RI62597



RIDGID

RIDGE TOOL CO.

Drain Line Cleaners

Model No. K-50-4

Model K-50 - For 3/4" to 4" (19-100 mm) Drain Lines.

- Compact, versatile, professional's machine. Capable of running three different size cables: 5/16", 3/8" and 5/8" - the perfect, all-around sink, shower, and floor drain machine; weighs less than 35 lbs.



Unique, easy-to-use, instant-acting cable clutch maximizes operator control:

- Pull handle down and cable spins at 400 RPM
- Release handle, cable stops - instantly
- Uses sections of 5/8" cable, cleans 1-1/4" to 4" lines up to 100 feet
- C-8 best for 1-1/4 - 3" drains
- C-9 best for 2 - 4" drains
- 5/16" best for 3/4" to 1-1/2" lines
- 3/8" best for 1-1/4" to 2" lines

Item #	Desc.	Model No.
RI58960	Machine, with: A-30 Cable Kit	K-50-4

RIDGE TOOL CO.

Drain Line Cleaners

Model K-60SP - For 1-1/4" to 4" (32-100 mm) Drain Lines

- A compact machine for institutional, commercial or residential cleaning; also ideal for septic tank, vacuum truck operators. Small enough to fit into cramped spaces, yet powerful enough to clear tough blockages
- Ideal for roof-top vent stacks. Rear handle allows for easy transporting up ladders and onto roof tops



Item #	Desc.	Model No.
RI66492	Machine with A-1 Operator's Mit, A-12 Pin Key, and A-60-12 Rear Guide Hose	K-60SP
RI66497	Machine with A-1 Operator's Mit, A-12 Pin Key, and A-60-12 Rear Guide Hose, Plus: A-61 Tool Kit, A-62 Cable Kit	K-60SP-SE
RI66512	Machine with A-1 Operator's Mit, A-12 Pin Key, and A-60-12 Rear Guide Hose	K-60SP

RIDGE TOOL CO.

Drain Cleaner Cable

1-1/4" X 15'

Fits K-1500 Unit

- No. 62280 - 15' standard all purpose wind 3/8" pitch, good for 4" traps and 3 to 8" lines.



Item #
RI62280

RIDGE TOOL CO.

Drain Cleaner Accessories

For C-10 Cable

Fits K-60SP & K-3800 Machines

- 27642 - T-125 Retrieving Auger
- 62860 - T-103 Sawtooth Cutter, 2-1/2"
- 62930 - T-112 4 Blade Cutter, 1-3/4"



Item #
RI27642
RI62860
RI62930
RI62275

RIDGE TOOL CO.

Drain Line Cleaners

Model K-1500SP - For 2" to 10" (50-250mm) Drain/Sewer Lines

- All the features of the standard K-1500 with extra power to clean larger lines (10") and longer distances (through 300 feet); cuts through blockages fast
- Equipped with full 1 HP TEFC motor and heavy-duty rotary switch
- Unique easy-to-use instant-acting cable clutch maximizes operator control:
- Release, frees cable instantly, no overrun to loop or damage cable
- Low-profile frame design will fit most crawl spaces
- Easy clutch jaw change-out adapts the K-1500 SP to use 7/8" cable to clean 2" to 4" lines through 175 feet (order jawset A-368X, 59325)



Item #	Desc.	Rating (Volts-hz)
RI43507	Machine with A-1 Operator's Mitt and A-12 Pin Key, Plus: -A-34-12 Rear Guide Hose	120 - 60
RI46907	Machine with A-1 Operator's Mitt and A-12 Pin Key, Plus: -A-34-12 Rear Guide Hose -150 Feet, Ten Sections of C-11, 1 1/4 in. Cable - Three A-8 Cable Carriers -A-3 Tool Box -Eight-Piece 1 1/4 in. Tool Package	120 - 60
RI43512	Machine with A-1 Operator's Mitt and A-12 Pin Key, Plus: -A-34-12 Rear Guide Hose	220/240 - 50

**Don't see the Ridgid product you're looking for?
Call Edge today for information on other Ridgid tools.**



REED MFG
Cutter Wheels

All Reed cutter wheels are made from high shock-resistant tool steel, while competitive cutter wheels are made from carbon steel or still lower quality tool steel. By using this higher quality raw material, Reed cutter wheels can be made thinner and can therefore cut pipe more easily and leave less burr. Also, because of their higher quality, certified material, only Reed cutter wheels can be heat-treated for the perfect balance between hardness and toughness to make Reed cutter wheels resist breakage and last longer.

Reed pioneered the development of cutter wheels for plastic pipe and today has the widest variety and highest quality cutter wheels for various types and wall thicknesses of plastic pipe and tubing.

Reed offers the largest cutter wheel line for all types of pipe, tubing and conduit. Reed cutter wheels are the best value for use in Reed cutters, or in the cutters of any other manufacturer.



Item #	Std. Pack	Reed Cutter	Blade Exposure (in.)	Application
For Tubing Cutters - Metal				
RDOSS	12	TC1Q, TC1.6Q, TC2Q, T10, T15, T20	0.160	Stainless Steel
RDO	12	TC1Q, TC1.6Q, TC2Q, T10, T15, T20, MC3, RT15T1, RT15T2, RT15T3, RTC1.1, RTC1.4	0.180	Copper, Aluminum, Brass, Steel Tubing
RD30-40	12	TC3Q, TC4Q, TC5Q, TC6Q, TC8Q	0.250	Copper, Aluminum, Brass, Steel Tubing
RD345T	12	MC2	0.146	Copper, Aluminum, Brass
For Tubing Cutters - Plastic				
RD1-2PVC	12	TC1Q, TC1.6Q, TC2Q, T10, T15, T20	0.280	PVC, CPVC, PVDS
RD30-40P	12	TC3Q, TC4Q, TC5Q, TC6Q	0.343	ABS, PE, PP
RD680PVC	4	TC6Q, TC8Q	0.575	PVC - Standard & Heavy Wall, CPVC
RD3-6PVC	12	TC3Q, TC4Q, TC5Q, TC6Q	0.377	3"-6" PVC, 4" Heavy Wall CPVC
For Pipe Cutters				
RD2RBS	12	2-1, 2-1Q, 2-4WG, 2-3, 2-3Q, 2-4, 5301PD	0.300	Steel, Stainless Steel
RD2RBHD	12	2-1, 2-1Q, 2-4WG, 2-3, 2-3Q, 2-4, 5301PD	0.296	HD for Steel, Stainless Steel
RDR1032/S	6	5301PD	0.450	Steel, Stainless Steel, Schedule 80
RD3RG	4		0.399	Steel, Stainless Steel
For Hinged Cutters				
RDHS4	4	H4	0.320	Steel, Stainless Steel

REED MFG
**Pipe Cutter
C Shape**

Easy-to-grip cutter easily snaps on to copper tubing for a quick, clean cut. Just turn the cutter in the direction of the arrow and the cut will be complete in seconds. Compact c-shape means no handle swing space is required. The spring-loaded cutter wheel self-feeds on Type K, L, and M copper and CTS CPVC with consistent pressure as the tool is turned around the tubing. Each cutter fits just one popular size of copper tubing.



Item #	Pipe Capacity (in.)	Application
RDTC50SLR	1/2	CTS CPVC, Hard M copper, L copper, and soft K copper
RDTC50SL	1/2	CTS CPVC, Hard M copper, L copper
RDTC72SLR	3/4	CTS CPVC, Hard M copper, L copper, and soft K copper
RDTC75SL	3/4	CTS CPVC, Hard M copper, L copper
RDTC1SLR	1	CTS CPVC, Hard M copper, L copper, and soft K copper
RDTC1SL	1	CTS CPVC, Hard M copper, L copper



REED MFG
Hinged Cutters™

- Four wheels cut steel, stainless steel, cast and ductile iron with only 90° to 110° handle swing
- Only 4" clearance required around pipe
- Strong guide fingers ensure perfect alignment for square cuts
- A closed 360° frame forces all energy into cutting the pipe for maximum efficiency
- This is the only hinged cutter that tracks every time and the only one recommended for ductile iron, steel, and stainless steel to Schedule 100
- Note: S= comes with wheels for steel; I= for cast and ductile iron; X= for schedule 80 steel; XX= for schedule 100 steel.



Item #	Nom. Pipe Capacity (in.)	Length (in.)
RDH21/2S	1 - 2½	17
RDH21/2I	1 - 2½	17
RDH21/2X	1 - 2½	17
RDH4S	2 - 4	22
RDH4I	2 - 4	22
RDH4X	2 - 4	22
RDH6S	4 - 6	28
RDH6I	4 - 6	28
RDH6X	4 - 6	28
RDH8S	6 - 8	32
RDH8I	6 - 8	32
RDH8X	6 - 8	32
RDH8XX	6 - 8	32
RDH12S	8 - 12	34
RDH12I	8 - 12	34
RDH12X	8 - 12	34
RDH12XX	8 - 12	34

REED MFG
Tube Deburring Tools

- Tools deburr aluminum, copper, and steel tubing

Item #	Desc.
RDDEB0	Deburring Tool
RDDEB3	Deburring Tool
RDDEB38	Replacement Blade Only



REED MFG
Tripod Chain Vise

Manufactured with the heaviest gauge steel, overlapping hinges, and the best adjustable tray clamp, not a set screw, to keep the lower tray assembly and entire portable workbench tight – even after many hours of use! The heavy-duty design permits use with pipe up to 6" diameter. The exclusive double-faced jaws provide a second set of jaws with options available for both metal and plastic pipe (R450P).



Item #	Pipe Capacity (in.)
RD450+	1/8-6

REED MFG
Field Pipe Vise

- Field Pipe Vise holds pipe up to 20" diameter
- More pipe capacity than other Reed vises; 2,000 lb. vise capacity
- Super choice for pre-trench work and above ground cuts
- Excellent flexibility achieved in height and length of vise appropriate to application as customer may cut own pipe for legs and backbone



Item #	Pipe Capacity (in.-Nom.)
RDFPV20	2-20

REED MFG
Electric Hydrostatic Test Pumps

- Designed for pressure testing water systems such as water meters, plumbing lines, pressure vessels, solar systems and sprinkler systems, in both residential and commercial buildings. A standard 110V outlet is required and the electric motor is UL certified. The output pressure is easily adjusted simply by turning a knob and watching the attached gauge. A built-in bypass allows for automatic water recirculation once the set pressure is reached. When the pump is turned off, it can be easily disconnected from the test system and taken elsewhere or stored away. The hose-to-pump connection features a quick disconnect with built-in check valve, which allows for convenient setup and portability. Each pump includes a high pressure EHTPOUTHOSE for filling the system.



Item #	Capacity
RDEHTP500	500 PSI
RDEHTP500C	500 PSI



PIPE TOOLS & VISES
SINCE 1896

REED MFG
**Hydrostatic Test
Pumps**



Designed to test water meters, plumbing lines, pressure vessels, solar systems and sprinkler systems, in both residential and commercial buildings. The test pumps are portable and can be used to test modest irrigation lines. Pump operation requires the user to first fill the system that needs to be tested. Next, the user raises the system pressure by actuating the test pump handle. Finally, the user closes the pump's ball valve at the desired pressure. The user determines leakage based on dropping pressure as indicated by the hydrostatic test pump's pressure gauge. The pump has a relief valve that reduces the likelihood of over-pressuring the system. Hoses are sold separately.

Item #	Capacity (psi.)
RDHTP300	300
RDHTP1000	1000

**Test your
fire sprinkler
systems**

REED MFG
Universal Pipe Cutters



- Lightweight, easy-to-use Universal Pipe Cutters (UPC) are available to cut 6" - 48" (150-1300 mm) outside diameter ductile iron, cast iron, clay, concrete, steel, PVC, or PE pipe
- The cutters are pneumatic powered
- The lower cost RDUPC616A uses the same motor as the others, but does not need connecting frames
- The RDUPC616 is shipped in a steel toolbox with a three-gallon, formed-steel water tank
- The RDUPC636A and RDUPC648A come in a steel toolbox with a seven-gallon, stainless steel water tank and cart
- Must order required blades separately

Item #	Pipe Dia. (Inches-Nom.)
RDUPC616A	6-16
RDUPC636A	6-36
RDUPC648A	6-48

REED MFG

**Manhole Hooks
High Carbon Steel**



- Forged with high carbon steel
- RDMH30 has rotated handle and rocker head to more easily enter notch in stubborn covers
- Points are 1/2" wide for cover openings

Item #	Handle To Hook Relationship	Length (in.)
RDMH26	Same Plane	26
RDMH30	Hook 90° To Handle	30
RDMH36	Same Plane	36

REED MFG

PE Squeeze-Off Tools



- Reed offers the best designed tools for stopping flow in PE pipe with capacities of 1/2" to 8"
 - Sliding bar handles make work in tight places easier and increase leverage for tightening
 - Other features include fine-pitched thread to allow for a controlled, low-effort squeeze; greased fittings to make operation easier and extend life; and aluminum parts to make tools lighter for easier handling
 - Aluminum castings also withstand varied climate and soil conditions
 - All tools use positive stops to prevent damage caused by over-clamping
 - PES1 models feature a stationary bottom bar
 - The PES2 and PES4 series have an affixed bottom bar, which swings open to fit over any location on the pipe
 - RDPE2PC160 features CTS-specialized stops for Pressure Class 160 tube
 - PES2-2 models have a new double-bar design with two squeeze points in a row which provide better shut-off and extra protection against leaks, right in one tool
 - Reed's PES8s are available in manual or hydraulic models and also feature the new double-bar design - RDPE8M requires manual operation, uses two stops, and allows a dozen different pipe/SDR combinations - RDPE8H utilizes a hydraulic pump and offers a pressure gauge and saddle clamps
 - An optional Flow Control Valve Kit is available to control release of the upper jay to reduce risk of static build-up
 - Attention Utility Contractors: PES2 models can be used on both CTS and IPS PE pipe by simply changing the safety stops
- *RDPE2PC160 Rated for working pressure to 160 psi

Item #	Capacity (in.)	Pipe/SDR Stops	Length (in.)
RDPE11PS	1/2-1	3	11
RDPE1CTS	1/2-1	3	11
RDPE2IPS	1/2-2	6	12
RDPE2CTS	1/2-2	6	12
RDPE2PC160	1/2-2	6	12
RDPE4	2-4	7	20
RDPE8M	3-8	12	28
RDPE8H	3-8	12	28
RDPE2-2IPS	1/2-2	6	12
RDPE2-2CTS	1/2-2	6	12



PIPE TOOLS & VISES
SINCE 1896

REED MFG
Valve & Curb Keys

- Upper shafts are made from heavy-gauge, mechanical steel tubing
- The keys have a telescoping design
- When telescoped in, they are under 4 feet long and fit easily in small utility trucks, behind pickup seats, and in car trunks
- When telescoped out, lengths of 5 feet to 7 feet are possible
- RDVK10 reaches nearly 10 feet when fully extended
- RDVKEXT shaft is available to extend the keys to over 12 feet
- For greater control and versatility, a variety of tools can be used on the end of T handles to turn curb stops
- Optional clip-on tools can be used to turn small valve wheels, curb box rods, pentagon bolts, and Buffalo box lids; Reed customers can choose keys according to the needs of their systems
- The RDVKA45 (shown in picture) is an adjustable valve key for mains with the curb key at a 45 degree angle; this angle provides a visual indication of a ball valve's open or closed status, the handle lines up with the pipe when the valve is in the open position - the handle crosses the pipe (seeming perpendicular) with the valve in the closed position
- RDVK916PENT fits gas company curb stops and lids with its 9/16" pentagon key
- RDVKEXT is an extension bar with 3 positions that can be used on most Reed keys for up to 6 feet of extra reach
- RDVKKIT uses the VK3 upper shaft to create all VK2 and VK3 variations of valve keys



Item #	Desc.	Closed Length (in.)
RDVKA	Adjustable Valve Key for Mains	45.5
RDVKA45	Adjustable Valve Key with 45° angle Curb Key	45.5
RDVK2CK1	Main Valve Key + 1" Curb Key	45.5
RDVK2CK2	Main Valve Key + 2" Curb Key	45.5
RDVK2COMBO	Main Valve Key + Combination curb box pentagon & rod tool	45.5
RDVK916PENT	9/16" Pentagon Key	45.5
RDVK3CK1WHL	Main Valve Key + 1" Curb Key + valve wheel 2 prong tool	45.5
RDVK3CK1-2HL	Main Valve Key + 1" Curb Key + 2 prong tool for 2 hole curb boxes	45.5
RDVK3CK1COMBO	Main Valve Key + 1" Curb Key + Combo curb box pent. & rod tool	45.5
RDVK3CK1ROD	Main Valve Key + 1" Curb Key + 3/8" slotted tool for curb box rods	45.5
RDVK3CK1CK2	Main Valve Key + 1" Curb Key + 2" Curb Key	45.5
RDVK3CK1EXT	Main Valve Key + 1" Curb Key + Extension shaft for additional 6' reach	45.5
RDVKKIT	Kit contains parts to make all VK2 and VK3 variations using the VK3 upper shaft	45.5
RDHWVK	Hydrant Wrench with hole to attach to valve key	20
RDVK3CK1HW	Valve Key with CK1 curb key and Hydrant Wrench	45.5
RDVK10	Basic 10' Valve Key	65.0
RDVK10-3CK1CK2	10' Valve Key with CK1 and CK2 Keys	65.0
RDVK10-3CK1EXT	10' Valve Key with CK1 Key and Extension	65.0
RDVKEXT	Valve Key Extension	72.0



REED MFG
Universal Pipe Cutter Blades



Item #	Desc.	Pipe Dia. (in.)	Pipe Material
RDUPCARB4	4" Blades cut up to 2 ³ / ₃₂ " wall thickness	6	PVC
RDUPBEVEL	Available by special order, minimum order applies		PVC
RDUPCARB6	6" Blades cut up to 1 ²³ / ₃₂ " wall thickness	8 - 48	PVC
RDUPCSTEEL4	4" Blades cut up to 2 ³ / ₃₂ " wall thickness	6-8	Steel, PE
RDUPCSTEEL6	6" Blades cut up to 1 ²³ / ₃₂ " wall thickness	8-48	Steel, PE
RDUPDIA6C	6" Blades cut up to 1 ²³ / ₃₂ " wall thickness	8-48	Cast Iron, Pit Cast, Ductile Iron Clay, Concrete
RDUPDIA4C	4" Blades cut up to 2 ³ / ₃₂ " wall thickness	6	Cast Iron, Pit Cast, Ductile Iron Clay, Concrete

REED MFG
Valve Wheel Wrenches



- Reed valve wheel wrenches grip the rims of hand valve wheels securely and provide leverage for opening and closing
- Choose a wrench based on the hook opening
- RDVKVW fits standard valve nuts and is made of heavy-duty mechanical steel tubing
- RDVWALP1 and RDVWALP2 offer a low-sparking benefit due to aluminum-magnesium alloy construction

Item #	Style	Material	Hook Opening (in.)	Length (in.)
RDVKVW	2" Square Nut	mechanical steel tubing	2" Square	21
RDVW0	Double-end	forged steel	1/2 & 2 ¹ / ₂	8
RDVW1	Single-end	forged steel	1	15
RDVW2	Single-end	forged steel	1 ⁵ / ₁₆	22
RDVW3	Single-end	forged steel	2	27
RDVW10	Double-end	forged steel	1 ¹ / ₁₆ & 1	10
RDVWALP1	Single-end	aluminum	1 ³ / ₈	14
RDVWALP2	Single-end	aluminum	1 ³ / ₄	18



ROTHENBERGER
Ropower 50R Compact Threading Machine

The Ropower 50R uses Ridgid®-compatible dies with the new quickchange ball detent feature. While other manufacturers' Ridgid® style dies may be used in the 50R die head (56265), only Rothenberger's dies snap into position.

- Machine slightly angled: Reduced oil consumption, oil moistening in pipe interior is avoided
- NPT dia.: 1/4"-2" capacity
- Includes: Automatic die head with NPT Alloy dies 1/2"-2", 1/2"-3/4" NPT dies (89162), 1"-2" NPT dies (89163)



Item #	Desc.
RO63005	Ropower 50 R

Accessories

RO56051	Wheeled Folding Stand
RO04510R	Cutter Wheel



ROTHENBERGER

ROTHENBERGER
**Rocam® Mobile Cordless
Drain Inspection Camera**

- Flexible camera head for excellent maneuverability
- Continuously adjustable LED brightness
- Integrated storage compartment
- For hollow spaces and drains of 2" to 6"
- Camera head diameter 1-1/4"
- Push cable diameter 3/16"
- Push cable length 118 ft.
- On-board battery charger with charge status indicator: Battery is always charged
- Fold down monitor cover: Acts as sun visor for best viewing of image
- Video In/Video Out: For optional video recording and playback
- Pinhole lens with LED illumination: Brilliant, clear image for easy diagnosis



Item #
RO69635NT

ROTHENBERGER
**Ropress Corded
Crimping Tool**

State-of-the-art crimping tool.

- Interchangeable crimping jaws: Flexible and cost effective
- Secure grips and innovative 2-component housing allows easy 1-handed operation



Item #	Desc.
RO16201	Ropress Corded Tool, No Jaws
RO16202	Ropress Corded Tool, 1/2"-2" Jaws
RO15222X	Press Jaw, 1/2" Copper
RO15223X	Press Jaw, 3/4" Copper
RO15224X	Press Jaw, 1" Copper
RO15225X	Press Jaw, 1 1/4" Copper
RO15226X	Press Jaw, 1 1/2" Copper
RO15227X	Press Jaw, 2" Copper
RO15251X	Press Jaw, 3/8" PEX
RO15252X	Press Jaw, 1/2" PEX
RO15253X	Press Jaw, 5/8" PEX
RO15254X	Press Jaw, 3/4" PEX
RO15255X	Press Jaw, 1" PEX
RO15256X	Press Jaw, 1 1/4" PEX
RO14486	GO/NO GO Calibration Gauge 3/8", 1/2", 5/8", 3/4" ASTM F1807 PEX
RO14487	GO/NO GO Calibration Gauge 3/8", 1/2", 3/4", 1" ASTM F1807 PEX

SUMNER

SUMNER
**Material Lift
Roust-A-Bout**

The Sumner Roust-A-Bout enables one man to lift and place loads in tight locations that would be impossible with other lifts. The flexible Roust-A-Bout not only makes the job possible . . . it can pay for itself in days by reducing job time.

This dependable lift can raise a 1,500 lb. (682 kg) load to heights up to 25 feet (7.6 m) in minutes. In addition, the load can be moved vertically and horizontally at the same time. Wider loads (up to 1,000 lbs.) can be handled with the addition of Sumner's Tee Head Extension Bar. The Roust-A-Bout eliminates the need for many other tools such as come alongs, scaffolds, monorails, and swing booms.



- Lifts 1,500 pounds (680 kg)
- 15', 18' and 25' heights
- Moves vertically and horizontally
- Separate load and mast winches
- 2-speed winch
- Infinite load height adjustment
- Ideal for job site or shop
- Mast and base separate quickly for EASY transport

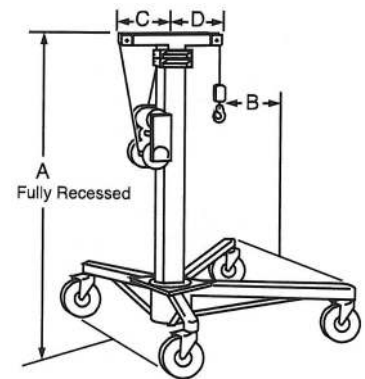

Item #	A	B	C/D	Base	Max Height
SU780300	79"	20"	12"	32" x 40"	15'
SU780301	79"	20"	12"	40" x 40"	15'
SU780302	126"	25"	14.5"	50" x 50"	18'
SU780303	119"	30"	17.5"	60" x 60"	25'

SUMNER
Tee Head Extension Bar

- Expands the Roust-A-Bout for handling bulky loads up to 1000 lb.

Item #	A	B	C
SU781060	22"	43"	48"
SU781061	29"	58"	63"
SU781062	37"	73"	68"

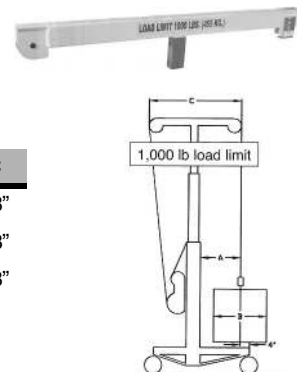

SUMNER

SUMNER Contractor Lifts Manually Operated Series 2100

- 12', 18', and 24' heights
- 650 lb. capacity
- One-piece, lightweight design
- Fast action stabilizer legs
- Compact storage
- Sumner-built winch
- Can be stored in the folded, compact position
- Rolls in upright, stored position
- Load cable away from operator
- Unique mast hold-down system



Item #	Model	Max. Height (forks up)
SU783650	2112	13 in. 1 in.
SU783651	2118	18 ft. 6 in.
SU783652	2124	23 ft 11 in.

SUMNER Contractor Lift

- A super compact 12 ft (3.6m) lift
- 400 lb (180 kg) lifting capacity
- One piece construction –no loose pieces
- Easily portable for one person operation
- Fits most SUVs and vans
- 13 ft. height when forks reversed
- Height max. (forks up) 13.0'
- Height max. (forks down) 12.0'
- Lift capacity 400.0 lb.
- Height stowed 62.8"
- Length stowed 23.0"
- Length operating 48.0"
- Width stowed 26.4"
- Width max 26.4"
- Winch cranks per ft/m 8
- Basic weight 195.0 lb



Item #	Model
SU784750	2412

SUMNER Pipe Jack Heavy-Duty

- 2,500 lb. (1135 Kg) capacity
- 1" square tube base construction
- Quick action lockwasher for fast height positioning
- Patented Fall Guard™ feature allows 1" (25 mm) safety zone around lockwasher



Item #	Model	Desc.
SU780375	ST-801	w/Vee-Head
SU780376	ST-802	w/Roller Head

SUMNER Pipe Jack Pro Jack

- Formed steel legs
- 2,000 lb. (900 Kg) capacity
- Quick action lockwasher for fast height positioning
- Patented Fall Guard™ feature allows 1" (25 mm) safety zone around lockwasher



Item #	Model	Desc.
--------	-------	-------

Pro Jack - Hi Jacks

SU780471 ST-871 w/V" Head

Pro Jack - Low Jacks

SU780472 ST-872 w/Roller Head

SUMNER Pipe Jack Fold-A-Jack

- Folds up for storage ease
- 1" square tube base construction
- 2,500 lb. (1,134 Kg) capacity
- Quick action lockwasher for fast height positioning
- Patented Fall Guard™ feature allows 1" (25 mm) safety zone around lockwasher



Item #	Model	Desc.
--------	-------	-------

SU781300 ST-881 w/Vee-Head

Fold-A-Jack - Hi Jack

Fold-A-Jack - Lo Jack

SU781301 ST-882 w/Roller Head

SU781305 ST-886 w/Ball Transfer Head

SUMNER Pipe Jack Stand Fat Jack

- Large vee head
- Wide base
- Folding base

Item #
SU781375



SUMNER V-Head Assembly

B-16F Fold-A-Jack

Item #
SU780518



SUMNER

SUMNER **Hold Down Device** *Max Jack*

- Uses high tensile strength chain for gripping up to 12" pipe onto the large vee-head when either welding or using the Max Jax for material handling
- Chain extension kits are available for pipe up to 40"



Item #
SU781050

SUMNER **Pipe Jack Stands** *Pro Roll*

- 1/2 – 48" or 2,000 lb. (900 Kg) capacity
- Adjustable height
- Leveling on either side of stand
- Handles large enough to grip with a gloved hand



Item #	Wheel
SU780441	Steel
SU780443	Rubber

SUMNER **Pipe Jack Stand**

Base Only *Adjust-A-Roll*

- Base only



Item #
SU780399

SUMNER **Pipe Jack** *Adjust-A-Roll*

- 1/2" to 48", or 2,000 lb. (900 Kg) pipe capacity
- Roller adjustment from either side
- Fast adjustment for easy pipe positioning



Item #	Wheel
SU780360	Steel
SU780362	Rubber

SUMNER **Ball Transfer Head** *Adjust-A-Roll*

- Q.C. ball-transfer head

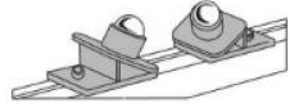

Item #
SU783154

SUMNER **Pipe Clamp** *Ultra Clamp™*

- Rugged frame, built for jobsite use
- Smooth roller clamping action for positive gripping
- Stainless steel contacts and alignment screws
- Operating handle repositions for close work
- Fine adjustment screws for quick fit-up
- Light weight for overhead work



Item #	Description
SU781130	1"-2½"
SU781150	2"-6"
SU781170	5"-12"

SUMNER **Pipe Clamp** *Ultra Fit*

- A fast accurate fit-up clamp for fitting to fitting
- Rugged compact design to operate in tight locations
- Stainless steel contacts and alignment screws
- Two-hand operating handle for positive gripping
- Fine adjustment screws for quick fit-up
- Light weight for overhead work
- Smooth roller clamping action for positive gripping



Item #	Description
SU781265	1"-2½"
SU781275	2"-6"
SU781285	5"-12"

SUMNER **Welding Clamps Kit** *ST-106*

- Consists of metal carrying box, main block and chain, jack bars and instruction manual
- Large Clamp Champ includes double jack screws for reforming 20 mm pipe wall



Item #
SU781000

SUMNER

SUMNER

Internal Fit-up Clamp

- Can be used on all standard weld neck flanges and great with slipon flanges
- Contact points stainless steel
- One piece construction
- Quick action operation
- Priced right
- Available for 2"-12" pipe



Item #	Description
SU784100	2"-4"
SU784102	4"-8"
SU784103	8"-12"

SUMNER

Flange Alignment Pins Qwik Pins®

- Quick installing pins work to level flange (two-hole) for tack and weld-out
- Hardened tapered Quick Pins automatically center on 5/8" - 1-5/8" holes
- Features acme threads for maximum clamping power and hardened steel for long-lasting use



Item #
SU781235

SUMNER

Flange Leveler

- Two hole and level in one time saving operation
- Uses bush-button Qwik Pin nuts for fast action
- Features stub Acme threads for maximum clamping and hardened steel for lasting use
- Automatically centers in flange holes 5/8"-1-5/8"
- Easily replaceable vials in the event of breakage



Item #
SU781240

SUMNER

Grasshopper Cart Grasshopper®

Enables one man to lift 2,000 lbs. Unassisted!

- Special sliding chain block design accommodates long and short loads
- Carries up to 20" diameter pipe, toolboxes, fittings, and valves
- Length: 12' (366 cm)
- Width: 36" (91 cm)
- Height: 40" (102 cm)



Item #
SU780351

SUMNER Flange Pins

ST-106 Clamp Champ

- Quick installing pins work as convenient reference points to level flange for tack weld-out
- No tools needed
- Hardened tapered pins automatically center on holes
- Features Acme threads for maximum clamping power



Item #	Model	Description	Material
SU780430	ST-106	5/8"-1 5/8" holes	Carbon Steel
SU780429	ST-206	5/8"-1 5/8"	Stainless Steel
SU780650	ST-258	1 1/2"-2 5/8"	Carbon Steel

SUMNER

Cricket Carts Cricket™

- Transport 20 ft pipe lengths up to 1,000 lbs
- Ideal job-site material carrier
- Comes with ratchet hold-down strap and 16" tubed tires
- Quick handle disconnect for compact storage

Uses leverage to lift pipe

1. Use ratchet to secure cricket to pipe
 2. Use handle to flip cricket & pipe
 3. Reposition handle
- Great for flanges, fittings and valves



Item #
SU782699



SURFACE SHIELDS

Duct Cover Shield

- Self-adhering protective film has a high adhesion suitable for all types of duct work
- The water-based adhesive will not leave a residue on the metal after removal
- Special blend of polyethylene is highly resistant to tears or punctures
- Satisfy SMACNA guidelines during construction by providing temporary closures on open ductwork



Item #	Size (in. x ft.)	Color
SFDC24200	24 x 200	Clear
SFDC36200	36 x 200	Clear
SFDC48200	48 x 200	Clear



BERNZOMATIC
Propane Torches

- Adjustable flame control knob for ease in switching between different applications
- Instant-on trigger igniter for easy lighting
- General purpose flame

Item #

BZTS3000T



BERNZOMATIC
Propane Torches

- Swirl flame provides a hotter, more efficient flame
- Instant on/off trigger igniter with simple one-handed operation
- Lock button keeps torch lit for finger-free use

Item #

BZTS4000T



BERNZOMATIC
Propane Torches

Swivel Head

- 360° swivel torch head provides maximum accessibility for different applications
- Swirl flame targets heat output and provides a hotter, more efficient flame

Item #

BZTS99T



BERNZOMATIC
7-Piece Propane Torch Kit

- UL2317 Brass Torch
- 16.92 oz. Fat Boy Propane fuel cylinder
- Flame spreader
- Spark igniter; utility flame tip
- Additional sparker flints
- Durable molded plastic storage case



Item #

BZUL125

BERNZOMATIC
Spark Lighters and Flints

Item #

BZTX405

Replacement Flint

BZTX406



BERNZOMATIC
Propane Fuel Cylinder

Fat Boy

- Ideal for general soldering
- Flame temperature in air = 3450° F
- 20% more fuel (than standard 14.1 oz cylinders)

Item #

BZTX-9



BERNZOMATIC
Propane Fuel Cylinder

Fat Boy

- Ideal for medium to heavy soldering and brazing
- Flame temperature in air = 3600 F
- 20% more fuel (than standard 14.1 oz cylinders)

Item #

BZMG9



**Want Welding
Equipment?**

**Call an Edge
sales
representative**



BUILDINGS AND MATTERS, LLC

Hole Covers



- The industry's only core cover with a water-tight seal that keeps water out of open holes during construction
- Unique Dome Profile Has Many Benefits: optimizes material usage, minimizes tripping hazards, distributes structural capacity evenly - regardless of the diameter, allows holes as small as 2 inches apart to be covered, uses post-consumer recycled polypropylene that can be recycled
- Fluorescent Yellow
- No tools needed, simply press fit into hole until underside of rim is flush with floor
- Temperature Range: -20° F to 120° F
- Loads: Safety Factor >4 for a 150 psf load, >2 for a 250 pound load at the center
- To remove pry up with screwdriver (or similar tool) using the two slots on the underside of rim
- Made In The USA

Item #	Size Dia. (in.)
HP-P002.0	2
HP-P002.5	2½
HP-P003.0	3
HP-P003.5	3½
HP-P004.0	4
HP-P004.5	4½
HP-P005.0	5
HP-P005.5	5½
HP-P006.0	6
HP-P007.0	7
HP-P008.0	8
HP-P009.0	9

BUILDINGS AND MATTERS, LLC

Puncture Solution

The Puncture Solution is a lightweight, innovative plastic device that prevents water pipes from being nicked or punctured during sheetrock installation. It snaps quickly and easily around pipe junctions to protect them from incoming sheetrock screws:

- Screws can't penetrate the Puncture Solution's metal collar and are instantly deflected around the pipe, preventing any damage
- Screws can be fully driven into the sheetrock, so labor is not wasted removing and re-drilling the drywall screw
- Reduces liability from leaks that are notoriously hard to find and are often only detected after construction is complete and the water turned on
- Provides a better alternative than striker plates because it covers both sides of the pipe and leaves no bumps in the finished sheetrock
- Saves time and money with quick one handed snap on installation
- Provides a secure, tight fit between the stud and the pipe
- Isolates the pipe from the metal stud to prevent galvanic reactions
- Can also protect electrical wiring and conduit
- Standard size fits 1/2 inch to 1 inch pipe for insertion into a 1-3/8 inch punched hole



Item #

HP-PS



GREENLEE TEXTRON INC.
Wire Strippers/Cutters

**Serrated Nose Grip
The Terminators®**



- Serrated nose grip for wire pulling and straightening
- Pivot joints have hardened steel bushings
- Precision ground blades for consistent stripping and cutting

Item #	Desc.	Capacity
GR1916	Wire Stripper/Cutter for Use with Solid Wire	20 - 10 AWG (.5 mm δ - 6 mm δ *) PVC or THHN Insulation
GR1918	Wire Stripper/Cutter for Use with Small Gauge Solid Wire	30 - 22 AWG (.05 mm δ - .34 mm δ *) PVC or THHN Insulation

GREENLEE TEXTRON INC.
Heavy-Duty Hacksaw



- Over-molded rugged design for heavy-duty use and comfort
- Alternative 45 degree blade mounting allows for flush cutting
- Blade Length: 12"

Item #
GR333A

GREENLEE TEXTRON INC.
PVC Cutters



- Ratchet action for fast, easy cutting
 - Heat-treated, replaceable steel blade for long cutting life
- Specifications:
- Capacity: Up thru 1-1/4" PVC

Item #
GR864

GREENLEE TEXTRON INC.
Bubble Level

Mini-Magnetic



- Professional grade level with bending offset aid; mini torpedo design with Handy "no-dog" attachment for bending
- Three rare earth magnets provide superior holding strength
- Four vial design - 0 deg., 90 deg., 45 deg. and 30 deg.

Item #
GRL77

GREENLEE TEXTRON INC.
Laser Level

Mini-Magnet



- Professional grade laser level, mini torpedo design with handy "no dog" attachment for bending
- Three rare earth magnets provide superior holding strength
- Laser is capable of working on all planes
- Four vial design - 0°, 90°, 45° and 30°

Item #
GRL97

GREENLEE TEXTRON INC.
Hydraulic Driver Punch Kit

**Ram and Hand Pump
No. 7506**

- Slug-Splitter® Knockout Punches with capabilities up thru 10 gauge stainless steel
- Powerful 11-ton hydraulic ram
- 3 foot hose
- 1/2" through 2" Conduit Size Slug-Splitter® Knockout Punch Kit with Hydraulic Ram and Hand Pump



Item #
GR7506

GREENLEE TEXTRON INC.
**Ram and Hand Pump Hydraulic Driver
Punch Kit
Slug-Splitter®**

- Slug-Splitter® Knockout Punches with capacities up through 10 gauge
- (3.5 mm) stainless steel

Item #	Desc.
GR29451	7/16 x 4 1/4 in. Draw Stud
GR29452	3/4 x 5 1/2 in. Draw Stud
GR1924AA	Spacer-Short
GR1925AA	Spacer-Medium
GR1926AA	Spacer-Long





GREENLEE TEXTRON INC.

Hydraulic Drive Punch Kit Parts

- Capacity - Stainless Steel: 10 ga.



Item #	Desc.	Conduit and Pipe Hole Size (in.)	Actual Hole Size Diameter in. (mm)
GR28154	1/2" Conduit Size Punch	1/2	.885 (22.5)
GR28155	1/2" Conduit Size Die	1/2	.885 (22.5)
GR28156	3/4" Conduit Size Punch	3/4	1.115 (28.3)
GR28157	3/4" Conduit Size Die	3/4	1.115 (28.3)
GR28158	1" Conduit Size Punch	1	1.362 (34.6)
GR28159	1" Conduit Size Die	1	1.362 (34.6)
GR28160	1 1/4" Conduit Size Punch	1 1/4	1.701 (43.2)
GR28161	1 1/4" Conduit Size Die	1 1/4	1.701 (43.2)
GR28162	1 1/2" Conduit Size Punch	1 1/2	1.951 (49.6)
GR28163	1 1/2" Conduit Size Die	1 1/2	1.951 (49.6)
GR28165	2" Conduit Size Punch	2	2.416 (61.5)
GR28166	2" Conduit Size Die	2	2.416 (61.5)
GR36490	1 1/32" Punch Oiltight		1.210 (30.5)
GR36489	1 1/32" Die Oiltight		1.210 (30.5)

GREENLEE TEXTRON INC.

Punches

- Mild Steel Capacity: 10 ga.

Item #	Desc.	Actual Hole Size Diameter in. (mm)
GR721-1/2	1/2" Conduit Size Punch	.885 (22.5)
GR721-3/4	3/4" Conduit Size Punch	1.115 (28.3)
GR721-1-1/4	1 1/4" Conduit Size Punch	1.701 (43.2)
GR721-1-1/2	1 1/2" Conduit Size Punch	1.951 (49.6)
GR721-1	1" Conduit Size Punch	1.362
GR721-2	2" Conduit Size Punch	2.416
GR00042	Ball Bearing Draw Stud with 1" Hex Head - 3/8 x 1 5/8"	
GR304AVBB	Draw Stud - 3/4 x 2 15/16"	



GREENLEE TEXTRON INC.

Knockout Punches Slug-Buster®

- Unique punch profile splits slugs allowing easy slug removal
- Use with battery-powered, hydraulic, ratchet or manual drivers
- Uses standard Greenlee dies and draw studs

Specifications:

- Capacity: Mild steel up through 10 gauge (3.5 mm)
- Application: Punch mild steel, aluminum, fiberglass and plastic

Item #	Conduit and Pipe Hole Size (in.)	Mild Steel Capacity ga (mm)
GR7211BB-1/2	1/2	10 (3.5)
GR7211BB-3/4	3/4	10 (3.5)
GR7211BB-1	1	10 (3.5)
GR7211BB-1-1/4	1 1/4	10 (3.5)
GR7211BB-1-1/2	1 1/2	10 (3.5)
GR7211BB-2	2	10 (3.5)





GREENLEE TEXTRON INC.

Ram and Hand Pump Kit Parts

- 17697 and 36282 are included in 7646PG ram and hand pump kit
- 15908 includes 1 each of spacer- short, spacer- medium, spacer-long



Item #	Desc.
GR15908	Spacer Group

GREENLEE TEXTRON INC.
Hydraulic Hand Pump

- Lightweight and portable for use with Greenlee Punch Drivers
- Single speed
- Rugged steel pump body/reservoir with cast aluminum handle
- Operation: Manual-hand Capacity: 6,500 psi



Item #
GR767

GREENLEE TEXTRON INC.

Punch Units

Replacement Punches, Dies & Manual Draw Studs

- Unique punch profile splits slugs allowing easy slug removal
- Use with manual, ratchet, hydraulic or battery-powered drivers
- Uses standard Greenlee dies and draw studs

Specifications:

- Application: Punch mild steel, aluminum, fiberglass and plastic



Item #	Conduit & Pipe Size (in.)
--------	---------------------------

Replacement Punches

Replacement Dies

Replacement Manual Draw Studs

GR60237	
GR60246	1.21
GR124AV	¾
GR126AV	1
GR440AV	1½
GR442AV	2
GR249AVBB	1

GREENLEE TEXTRON INC.

Replacement Draw Studs

- For manual drivers
- Diameter x Length: 1/4 x 1-3/8 in. (6.4 x 35 mm)

Item #
GR1675AV



GREENLEE TEXTRON INC.

Draw Studs

Item #	Size
GR12097	¾" x 2 15/16"
GR12099	¾" x 4 ¾"
GR1675AV	¼" x 1 ⅞"
GR3026AV	1 1/8" x 7 1/2"



GREENLEE TEXTRON INC.

Ratchet Wrench

- Time-saving ball bearing head punches faster than wrench method; requires less than half the force of conventional ratchet drivers
- Punches up through 10 gauge mild steel with Greenlee Standard and Slug-Buster® punches; and 16 gauge



Item #
GR20495

GREENLEE TEXTRON INC.

Wrench Knockout Kit

Ratchet Slug Buster®

- 1" Hex Ratchet Wrench allows use with both 3/8" (19.1 mm) and 3/4" (9.5 mm) draw studs
- Description: 1/2"-2" Conduit Size Slug-Buster® Knockout Punch Kit
- Capacity Mild Steel (GA): 10



Item #
GR7238SB



GREENLEE TEXTRON INC.

Knockout Punch Kit Parts



Item #	Desc.	Actual Hole Size Diameter in. (mm)
Included in GR7304 knockout punch kit		
GR1429AV	2½" Conduit Size Punch	1.951 (49.6)
GR1430AV	2½" Conduit Size Die	1.951 (49.6)
GR1431AV	3" Conduit Size Punch	2.416 (61.5)
GR1432AV	3" Conduit Size Die	2.416 (61.5)
Included in GR7610SB Slug-Buster® ram and foot pump hydraulic driver kit		
GR2981AV	3½" Conduit Size Die	4.044
GR2982AV	3½" Conduit Size Punch	4.044
GR2983AV	4" Conduit Size Die	4.544
GR2984AV	4" Conduit Size Punch	4.544
Included in GR7625, GR7606SB, GR7610SB 4.544 Slug-Buster® ram and foot pump hydraulic driver kit		
GR2113AA	Draw Stud - ¾ x 5⅝	

GREENLEE TEXTRON INC.

Hydraulic Punch Driver and Kits Quick Draw®

- Compact, lightweight design for portability and fast, easy one-person operation
- Develops 8 tons of hydraulic force for easy punching, even in 10-gauge stainless steel depending on individual punch capacities
- Quick Draw® is perfect for fast, straight-on front panel punching
- Quick Draw 90®'s right angle driver head rotates over 180 degrees for maximum flexibility in tight working areas
- Quick Draw® Flex allows unlimited driver orientation to simplify access to work area



Item #	Desc.
GR7706SB	Standard - Quick Draw® Flex Driver, ½ in. through 2 in. Slug Buster® Conduit Size Punches and Dies, 2 Draw Studs, 1 Adapter, 1 Spacer and Case

GREENLEE TEXTRON INC.

Hydraulic Punch Driver and Kits

The Quick Draw™ and the Quick Draw 90™ Features:

- Optional step-saver adapter converts standard Greenlee punches thru 1-1/4 inch conduit sizes to use 7/16 inch draw stud (adapter and draw stud included with 7804SB only)
- Develops 8 tons of hydraulic force for easy punching, even in 10 gauge stainless steel depending on individual punch capacities
- Quick Draw is perfect for fast, straight-on front panel punching
- Quick Draw 90's right angle driver head rotates over 180 degrees for maximum flexibility in tight working areas



Item #	Desc.
GR7806SB	Standard - Quick Draw™ Driver, ½" thru 2" Slug Buster conduit size punches and dies 2 draw studs, 1 adapter, 1 spacer and case
GR7904SB	Quick Draw 90® Driver, 2 Draw Studs, 1 Adapter, 1 Spacer and Case
GR7906SB	Quick Draw 90™ Driver ½" thru 2" Slug-Buster conduit size punches, dies and draw studs and case



GREENLEE TEXTRON INC.
Ratchet Wrench

- 1" Hex Ratchet Wrench allows use with both 3/8" and 3/4" draw studs
- High-impact, rugged plastic carrying case



Item #
GR34941

GREENLEE TEXTRON INC.
Draw Stud Replacement

- Draw Stud 1-1/8' (28.6 mm) x 7-1/2' (190 mm) Replacement Part for 741BB/19977 and 742BB/19778 and 730EBB-120/21519 and 743BB/19980



Item #
GR3026AV

GREENLEE TEXTRON INC.
Knockout Punch Kits

**Manual
Slug Buster®**

- Assortment of commonly used Slug-Buster® knockout punches, packaged to meet the contractor's needs
- High-impact, rugged plastic carrying case



Item #	Conduit Size
GR7235BB	1/2 - 1 1/4 in.
GR7237BB	1 1/2 and 2 in.

GREENLEE TEXTRON INC.
Hydraulic Punch Driver Kit Parts

Item #	Desc.	Size (in.)
GR31872	Draw Stud	3/4 x 4 1/8
GR33967	Stud Adapter	3/8
GR1614SS	Draw Stud	3/8 x 2 13/16



GREENLEE TEXTRON INC.
Hydraulic Foot Pump

- Free both hands to position and hold the working tool
- Foot activated release lever
- Foot Capacity 6,500 psi



Item #
GR1725

GREENLEE TEXTRON INC.
Hydraulic Driver Kits

Ram and Hand Pump

- Fast, easy and simple to operate
- Punches 10 times faster than wrench method
- Can be used with all standard round, Slug-Buster® and Slug-Splitter® punches
- 3-foot hose
- Powerful 11-ton hydraulic ram



Item #	Desc.
--------	-------

GR7646 Driver with Hand Pump, Plastic Case Driver, Hand Pump, Standard Punches, Dies and Draw Studs for 1/2 in. through 2 in. Conduit, Plastic Case

GREENLEE TEXTRON INC.
Hydraulic Hand Pump Kit

- Punches 10 times faster than wrench method
- Can be used with all standard round, Slug-Buster® and Slug-Splitter® punches
- 3-foot hose
- Powerful 11-ton hydraulic ram



Item #
GR7310

GREENLEE TEXTRON INC.
Hydraulic Driver Kits

Ram and Hand Pump

- Compact design for field use on construction sites and maintenance jobs
- Punches 10 times faster than wrench method
- Can be used with all standard round, Slug-Buster and Slug-Splitter punch sizes
- 3 foot hose
- Powerful 11-ton hydraulic ram



Item #	Desc.
--------	-------

GR7310SB Driver, hand pump, Slug Buster® punches, dies and draw studs for 1/2" thru 2" and 2 1/2 thru 4" standard conduit size punches, dies and draw studs, adapter, spacers, Kwik Stepper® Step Bit and steel case

GREENLEE TEXTRON INC.
**Punch Dies
C-Frame**

Item #	Conduit Size (in.)
--------	--------------------

GR12085 1
GR12086 3/4
GR12087 1/2





GREENLEE TEXTRON INC.

Hydraulic Hand Pump

- Use with 1/2" through 4" conduit size and other round sizes only
- Use with Greenlee standard round punches and dies (optional)



Item #

GR755

GREENLEE TEXTRON INC.

Oiltight Punch Units

- With notches
- Includes punch die and draw stud
- Maximum Mild Steel Capacity: 10 ga., Operation Type: Hand/Hydraulic, Minimum Pilot Hole Diameter: .625 in.



Item #

GR60242

GREENLEE TEXTRON INC.

Keyway Punches

- Eliminates time consuming hand sawing and filing when making keyways for push button switches
- Use as a nibbler to make wider or deeper keyways
- Punches 1/8" (3.2 mm) or 3/16" (4.8 mm) keyways for 7/8" (22.5 mm) or 1-7/32" (30.5 mm) push button holes
- Capacity: 10 gauge (3.5 mm) mild steel



Item #

GR720

GREENLEE TEXTRON INC.

Plumber Stud Punch

- Punches 2-5/8" diameter hole in metal studs for professional looking installation of 2" water, vent, waste pipes
- Two-speed lever action for fast, easy punching of 24 to 20 gauge thick metal studs
- 2-1/8" throat width fits over most studs and channels



Item #

GR713

GREENLEE TEXTRON INC.

Metal Stud Punches

- Punch up through 20 gauge steel studs in one stroke
- Aluminum head provides strength with minimum weight, reducing operator fatigue
- Contoured handle design gives better operator leverage and makes it possible to punch in tight places
- Automatically centers holes on standard studs



Specifications:

- Capacity: 709 - 1-5/8" and wider studs, 20 gauge steel studs; 710 - 2-1/2" and wider studs, 20 gauge steel studs

Item #

Desc.

GR709 7/8" (22.2 mm) Diameter Stud Punch

GR710 1 11/32" (34.1 mm) Diameter Stud Punch

GREENLEE TEXTRON INC.

Stud Punches

Manual

- Punch up through 20 gauge steel studs in one stroke
 - Unique patented punch rolls the edge over for smooth installation of armored cable; cable won't hang up
 - Automatically centers holes on standard studs
- Actual Hole Size: 1-1/4 in., Capacity: 24 - 20 ga.



Item #

GR724

GREENLEE TEXTRON INC.

Drill/Tap/Countersink Bits

- Material thickness - 10 gauge
- Material type - mild steel, copper, brass, aluminum
- Shank - 1/4" quick change hex



Item #

Size

GRDTAP3/8-16 3/8-16

GRDTAP5/16-18 5/16-18

GRDTAP1/4-20 1/4-20

GRDTAP10-24 10-24

GRGRDTAP12-24 12-24

GRDTAP6-32 6-32

GRDTAP8-32 8-32

GRDTAP10-32 10-32

GRDTAPKIT



Kwik Stepper® Step Bits

- Unique split-tip design penetrates through steel faster.
- Resists walking or skidding, even on round surfaces.
- Balanced, double-flute construction requires less pressure, does the work for you.
- Designed and manufactured in USA.

CAT. NO. UPC. NO. DESCRIPTION

35884	35884	Kwik Stepper® Step Bit Kit
03607	03607	Kwik Stepper® Step Bit Kit

CAT. NO. UPC. NO. DESCRIPTION

CAT. NO.	UPC. NO.	DESCRIPTION	03607	35884
34401	34401	1/2" Multi-Hole Step Bit	X	X
34403	34403	7/8" Multi-Hole Step Bit	X	X
30008	30008	1-1/8" Multi-Hole Step Bit		X
35936	35936	Plastic Case	X	X

SPECIFICATIONS

Hole Sizes From 1/8" to 1-3/8" (3.2 - 34.9 mm)

Capacity Cut up through 3/8" (9.5 mm) mild steel, copper, brass, aluminum, wood, plastic and laminates

Single-hole bits are designed to drill one indicated hole size through a series of steps from bit tip to full size.

Multi-hole bits allow you to drill a hole in any of the stated diameters.

Bit Type	1/2" (12.7 mm)	1/2" (12.7 mm)	1/2" (12.7 mm)	13/16" (20.6 mm)	7/8" (22.2 mm)	7/8" (22.2 mm)	1-1/8" (31.8 mm)	1-3/8" (34.9 mm)	9.7 mm (.382")	30.5 mm (1.201")	32.5 mm (1.280")
Single-Hole Step Bit											

SIZE		CAT./UPC NO.										
INCHES	mm	34410	34401	36402	30005	34411	34403	30008	36414	36018	36020	36022
1/8	3.2		X									
5/32	4.0		X									
3/16	4.8		X	X	X		X					
7/32	5.6		X									
1/4	6.4		X	X	X		X					
9/32	7.1		X									
5/16	7.9		X	X	X		X					
11/32	8.7		X									
3/8	9.5		X	X	X		X					
0.382	9.7										X	
13/32	10.3		X									
7/16	11.1		X	X	X		X					
15/32	11.9		X									
0.492	12.5										X	
1/2	12.7	X	X	X	X		X	X				
9/16	14.3				X		X					
0.598	15.2										X	
5/8	15.9				X		X					
0.638	16.2											X
11/16	17.5				X		X					
0.732	18.6										X	
3/4	19.1				X		X					
0.803	20.4										X	X
13/16	20.6				X		X					
7/8	22.2					X	X	X	X			
0.886	22.5										X	
1.00	25.4											X
1.114	28.3										X	
1 1/8	28.6							X	X			
1.201	30.5								X			
1 7/32	31.0								X			
1 1/4	31.8								X			
1.280	32.5											X
1 3/8	34.9								X			



GREENLEE TEXTRON INC.

Step Bits

Kwik Stepper

- Unique split tip design penetrates through steel faster
- Resists walking or skidding, even on round surfaces
- Balanced double flute construction requires less pressure, does the work for you



Specifications:

- Hole Sizes: From 1/8" through 1-3/8" (3.2 - 34.9 mm)
- Capacity: Cut up through 3/8" (9.5 mm) mild steel, copper, brass, aluminum, wood, plastic and laminates

Item #

GR35884

GREENLEE TEXTRON INC.

Multi-Hole Step Bits

Item #	Size (in.)
GR34401	1/2
GR34403	7/8
GR30008	1 1/8

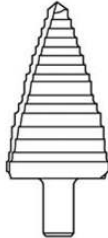

GREENLEE TEXTRON INC.

Multi-Hole Step Bits



1/2" (12.7 mm) Multi-hole bits allow you to drill a hole in any of the stated diameters. 3/16" 4.8 mm 1/4" 6.4 mm 5/16" 7.9 mm 3/8" 9.5 mm 7/16" 11.1 mm 1/2" 12.7 mm.

- Unique split tip design penetrates through steel faster
- Resists walking or skidding, even on round surfaces
- Hole Sizes: From 3/16" through 1/2" (4.8 - 12.7 mm)
- Capacity: Cut up through 3/8" (9.5 mm) mild steel, copper, brass, aluminum, wood, plastic and laminates
- Overall Length 3-3/16" (81.0 mm)
- Minimum Chuck Size 1/4" (6.4 mm)

Item #

GR36402

GREENLEE TEXTRON INC.

Kwik Stepper Bit

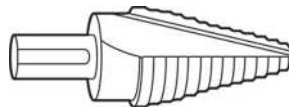

- 7/8" (22.2 mm) Single-Hole bits
- Unique split tip design penetrates through steel faster
- Balanced, double-flute construction requires less pressure, does the work for you
- Overall Length: 2-3/16" (55.6 mm)
- Minimum Chuck Size: 3/8" (9.5 mm)
- Hole sizes: From 1/4 through 7/8 (6.4 - 22.2 mm)

Item #

GR34411

GREENLEE TEXTRON INC.

Multi-Hole Step Bits



1-3/8" Multi-hole bits allow you to drill a hole in any of the stated diameters. 7/8" (22.2 mm) 1-1/8" (28.6 mm) 1.201" (30.5 mm) 1-7/32" (31.0 mm) 1-1/4" (31.8 mm) 1-3/8" (34.9 mm)

- Unique split tip design penetrates through steel faster
- Balanced, double-flute construction requires less pressure, does the work for you
- Capacity: Cut up through 3/8" (9.5 mm) mild steel, copper, brass, aluminum, wood, plastic and laminates
- Overall length: 3-1/8" (79.4 mm)
- Minimum Chuck Size: 3/8" (9.5 mm)

Item #

GR36414

GREENLEE TEXTRON INC.

Power Bits

Big Shank Shorty

Nail Eater II®



- Self-feeding screw point draws bit through wood
- Unique patented design cutting angle - smoother starts, reduced cutting loads
- Made of super tough heat treated steel; cuts through nails and provides longer life
- "Shorty" bits - for working in tight places, yet still can go through three abutting 2 x 4's

Specifications:

- Overall length: 7-5/8" (19.37 cm)
- 7/16 (11.1) hex shank

Item #	Hole Dia.
GR62PTS-5/8	5/8
GR62PTS-11/16	11/16
GR62PTS-3/4	3/4
GR62PTS-13/16	13/16
GR62PTS-7/8	7/8
GR62PTS-1	1
GR61/62PTS-1-1/8	1 1/8
GR61/62PTS-1[1/4]	1 1/4

GREENLEE TEXTRON INC.

Combination Drill Bits



Type B - with Screw Points

D'versiBIT®

- For aggressive chip removal in many types of woods
- Screw point for easy starting and pulling through wood
- Bit Dia: 9/16"
- Shaft Length x Dia.: 54" x 1/4"

Item #

GR38103



GREENLEE TEXTRON INC.
Wood Boring Bits

Nail Eater II®



- Self-feeding screw point draws bit through wood
- Unique patented design cutting angle - smoother starts, reduced cutting loads
- Made of super tough heat treated steel; cuts through nails and provides longer life

Specifications:

- Overall Length: 18" (457.2 mm)
- Twist Length: 15" (381 mm)

Item #	Hole Diameter in. (mm)	Hex Shank in. (mm)
GR66PT-1/2	1/2 (12.7)	5/16 (7.9)
GR66PT-5/8	5/8 (15.9)	7/16 (11.1)
GR66PT-11/16	11/16 (17.5)	7/16 (11.1)
GR66PT-3/4	3/4 (19.1)	7/16 (11.1)
GR66PT-13/16	13/16 (20.6)	7/16 (11.1)
GR66PT-7/8	7/8 (22.2)	7/16 (11.1)
GR66PT-15/16	15/16 (23.8)	7/16 (11.1)
GR66PT-1	1 (25.4)	7/16 (11.1)
GR66PT-1[1/8]	1 1/8 (28.6)	7/16 (11.1)
GR66PT-1[1/4]	1 1/4 (31.8)	7/16 (11.1)

GREENLEE TEXTRON INC.

Impact Bits

Nail Eater II®



- Quickly bore through creosoted and salt treated utility poles
- Resists wear, eats through nails and staples
- Self-feeding screw point draws the bit through the wood
- 7/16" hex shank to fit impact drivers
- Overall Length: 18" (457.2 mm)

Item #	Hardware Diameter in. (mm)	Hole Diameter in. (mm)
GR37868	9/16 (14.3)	5/8 (15.9)
GR37869	1 1/16 (17.5)	3/4 (19.1)

GREENLEE TEXTRON INC.

Pulling Grips

Wire & Cable

D'VersiGRIP



- D'VersiGRIP for pulling 3/4 in. (19.1 mm) OD wire with 3/4 in. to 1 in. (19.2 to 25.4 mm) bits

Item #
GR38693

GREENLEE TEXTRON INC.

Auger Bits



Type A

D'versiBIT®

- Wood-type auger bit with screw point
- Pulls itself through wood, avoids walking or skidding
- Excellent for drilling in soft woods or through thin sections
- Slow back-taper allows for easy retrieval

Item #	Bit Dia. (in.)	Color Code	Shaft Lgth. (in.)	Shaft Dia. (in.)
GR38068	3/8	Black	54	3/16
GR38083	3/4	Red	54	1/4
GR38088	1	White	54	1/4

GREENLEE TEXTRON INC.

Combination Drill Bits



Type C

D'versiBIT®

- For drilling in tough woods and thick obstacles
- Drilling speed relative to pressure applied
- Chips can be brought easily out of the hole

Item #	Bit Dia. (in.)	Shaft Length (in.)	Shaft Dia. (in.)
GR38113	1/4	54	5/32
GR38118	3/8	54	3/16
GR38119	3/8	72	3/16
GR38133	3/4	54	1/4

GREENLEE TEXTRON INC.

Starter Drill Bit Kit

D'VersiBIT®



- All the tools to complete a typical wiring job
- Includes 09-03-54B bit, 712P placement tool and 150 pulling grip

Item #
GRDBITKIT

GREENLEE TEXTRON INC.

Keyhole Saws

- Hack saw frames and blades
- Hardened steel blade makes cutting drywall, cement board, plastic and wood quick and easy



Item #
GR301



GREENLEE TEXTRON INC.
Hole Cutter Kits

Carbide-Tipped

- Multiple tungsten carbide tips for long life and smooth cutting
- Cut fast, accurate, high quality holes in stainless steel, copper, aluminum, steel
- Flange stop prevents over drilling



Specifications:

- Maximum Cutting Depth: 8 ga (4 mm)
- Kit Description: 7/8", 1-1/8", 1-3/8" cutterheads; pilot drill, hey key and case

Item #
GR635

GREENLEE TEXTRON INC.
Hole Saws
Quick Cutter™

- Quickest, most affordable way to cut perfect holes in drywall and ceiling tile
- Cuts clean, precise holes that ensure no light leakage or poor-fitting installations
- Dedicated arbor and pilot drill eliminates changeover time



Item #	Desc.
GR06923	Recessed Hole Saw, Adjustable 2 1/2" to 7" Cuts 2 1/2" to 7" Diameter Holes in Increments of 1/2"

GREENLEE TEXTRON INC.
Aluminum Hand Benders
SITE-RITE®

- Superior, patented Site-Rite® sighting system featuring cast-in, readable markings on the bender heads and a finish that provides for the best visibility in low-light
- Cast-in markings for accurate head-down and head-up bending as well as for producing stub-ups, offsets, saddles and back to back bends



Item #	Desc.
GR840A	1/2" EMT
GR841A	3/4" EMT
GR842A	1" EMT
GR843A	1 1/4" EMT

GREENLEE TEXTRON INC.
Hickeys with Welded Handles

- Heavy-duty cast steel head
- Welded steel handle
- Bend tight radius stub-ups
- 1/2 - 1 Rigid



Item #	Desc.
GR508	Hickey for 1/2 Rigid
GR512	Hickey for 3/4 Rigid
GR516	Hickey for 1 Rigid

GREENLEE TEXTRON INC.
Offset Benders
Little Kicker®

- Bends offsets in one easy operation; insert conduit, depress handle completely, release and remove conduit
- Makes identical offsets every time for wall mounted boxes with exposed conduit



Item #	Desc.	Capacity (in.)
GR1810	Offset Bender for 1/2 in. EMT	1/2 EMT
GR1811	Offset Bender for 3/4 in. EMT	3/4 EMT

GREENLEE TEXTRON INC.
Conduit Benders
855GX, Intellibender™

- Save time by eliminating bending calculations via the easy to use LCD interface to program 7 different bends with ability to save 3 locally or unlimited number to USB memory stick for recall later or to transfer to another 855GX bender
- Avoid scrap and speed bending with the patent pending auto conduit size and conduit type smart sensors
- Complete capability to bend 3/4" Rigid & 1 - 2" EMT/IMC/Rigid with no loose parts
- Superior portability, stability and on-board storage via fork tubes, hoist bar, large wheels, wheel brake bar, storage box and tray
- Quick pivot for changing between vertical and horizontal orientations (patent pending)
- Greater up-time with patent pending solid state controls utilizing current-limiting technology eliminates welded relay contact failures
- Ability to handle a wide range of job site power sources including generators and strong weatherability gives greater uptime and longer motor life as well as protects the electronics
- 120 VAC, 20A



Item #
GR855GX



GREENLEE TEXTRON INC.
Mechanical Benders

Mechanical benders for IMC and rigid conduit.

- Ratchet action for increased leverage
- Bypass the ratchet for fast, direct bending on small sizes
- Built-in bending degree indicator and easy to use bending charts for accurate, consistent bends; centerline bending radii for 1-1/2" Rigid conduit size 9-11/16" (246.1 mm)



Item #	Desc.	Rigid Conduit Size (in.)	Capacity	Centerline Bending Radii for 1 in. Rigid Conduit in. (mm)	Centerline Bending Radii for 1 1/4 in. Rigid Conduit in. (mm)	Centerline Bending Radii for 1/2 in. Rigid Conduit in. (mm)	Centerline Bending Radii for 3/4 in. Rigid Conduit in. (mm)
GR1800	Mechanical Bender for 1/2 in., 3/4 in., 1 in. IMC & Rigid Conduit	1/2, 3/4, 1	1/2 in., 3/4 in. & 1 in. IMC & Rigid	5 7/8 (149.2)		2 5/8 (66.7)	4 3/8 (117.5)
GR1801	Mechanical Bender for 1 1/4 in., 1 1/2 in. IMC & Rigid Conduit	1 1/4, 1 1/2	1 1/4 in. & 1 1/2 in. IMC & Rigid		8 1/16 (204.8)		

GREENLEE TEXTRON INC.
Mechanical Benders

Mechanical benders for EMT, IMC, rigid and aluminum conduit.

- Bends a wide variety of types and sizes of conduit
- Durable ratchet mechanism for easy bending
- Bypass the ratchet for fast, direct bending on smaller sizes
- Bending degree indicator and charts for fast, easy, accurate bending
- All shoe and bending accessories can be mounted to the frame unit and secured with a chain and lock
- Heavy-duty undercarriage with wheels



Item #	Desc.
GR1818	Mechanical Bender for 3/4 in. Through 2 in. EMT Conduit, 1/2 in. Through 1 1/4 in. IMC Conduit and 1/2 in. Through 1 1/2 in. Rigid and Aluminum Conduit

GREENLEE TEXTRON INC.
40 MIL PVC Coated Rigid Shoe Group

- Smooth wrinkle-free bends
- Capacity 1" - 2" EMT, IMC, and Rigid conduit



Item #
GR37279

GREENLEE TEXTRON INC.
Electric Conduit Bender 555C

Classic Electric Bender power unit without bending accessories

- The 555C Classic Series features simple relay controls for easy field repairs, and compact handle design to prevent interference with conduit when bending
- Power source: 120 VAC; 20 amp GFCI-protected receptacle



Item #
GR555C

GREENLEE TEXTRON INC.
Conduit Benders 555CX

- Most cost effective non-programmable bender - only need 2 shoes instead of 7 to bend all 3/4" - 2" EMT, IMC, Steel Rigid, Aluminum Rigid, Stainless Steel Rigid and PVC Coated Steel Rigid conduits
- Fully backwards compatible with existing shoes
- Same core frame and core control advantages found on the 855GX
- 555DX has absolute encoder to provide ease for repeated bends with digital angle readout on pendant and jogging capability
- Robust patent pending pendant with rare earth magnets to hold strong and impact resistant housing with over molding and cord strain relief
- 120 VAC, 20A



Item #
GR555CX



GREENLEE TEXTRON INC.

Conduit Benders

555DX

- Most cost effective non-programmable bender - only need 2 shoes instead of 7 to bend all 3/4" - 2" EMT, IMC, Steel Rigid, Aluminum Rigid, Stainless Steel Rigid and PVC Coated Steel Rigid conduits
- Fully backwards compatible with existing shoes
- Same core frame and core control advantages found on the 855GX
- 555DX has absolute encoder to provide ease for repeated bends with digital angle readout on pendant and jogging capability
- Robust patent pending pendant with rare earth magnets to hold strong and impact resistant housing with over molding and cord strain relief
- 120 VAC, 20A



Item #

GR555DX

GREENLEE TEXTRON INC.

EMT Bending Shoe

- 1/2" through 1-1/4" EMT bending shoe

Item #

GR17944

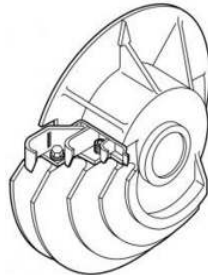

GREENLEE TEXTRON INC.

Support Roller

- 1/2" through 1-1/4" support roller

Item #

GR17986

GR17979

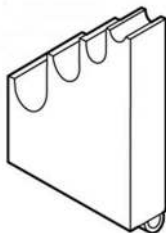

GREENLEE TEXTRON INC.

Bending Table

- Strong, portable pin-assembled aluminum components; easy-to-use ram travel scale and bending charts
- Conduit supports index to suit all sizes



Item #

GR1802

GREENLEE TEXTRON INC.

Conduit Benders

Cam Track®

- One bender to bend EMT, IMC and Rigid conduit
- Fast and easy set-up on the job-site
- True one shot 90° bends with CT models for quick accurate bends
- Steel reinforced follow bars for long life
- Bend a 90° elbow in 4" rigid conduit in 95 seconds
- Optional 1813 bending table and accessories for easier operation
- Capacity: 2-1/2" - 4 EMT, IMC and Rigid



Item #

Desc.

GR881CT Conduit Bender for One Shot 90 deg. Bends in 2 1/2 in., 3 in., 3 1/2 in. and 4 in. EMT, IMC and Rigid Conduit, without Hydraulic Pump

GREENLEE TEXTRON INC.

Bending Shoe Group

- For use with the 555 Series Deluxe Electric Conduit Benders and the 555C Series Classic Electric Conduit Benders
- To bend IMC conduit you must use the 26330 IMC Shoe Group
- To bend Rigid conduit you must use the 28007 Rigid Shoe Group
- 17944 - 1/2" through 1-1/4" EMT bending shoe
- 17986 - 1/2" through 1-1/4" support roller
- 23499 - 1-1/2" EMT bending shoe
- 23505 - 2" EMT bending shoe
- 23541 - 1-1/2" through 2" roller support unit
- 1723 (23818) - Metal storage box

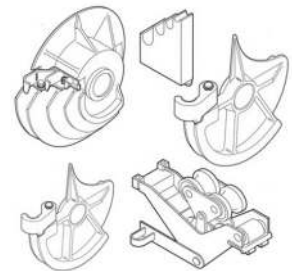

Item #

Desc.

GR23802 1/2-2 EMT

GR28007 1/2-2 Ridgid

GREENLEE TEXTRON INC.

Conduit Benders

For 881CT-E980:

- One bender to bend EMT, IMC and rigid conduit
- Fast and easy set-up on the job-site
- Steel reinforced follow bars for long life
- Bend a 90° elbow in 4" rigid conduit in 95 seconds

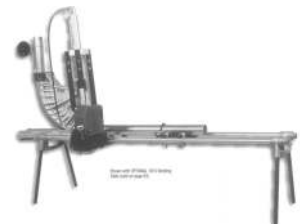

Item #

Desc.

GR1813 Bending Table for 881 Series Bender



GREENLEE TEXTRON INC.
Angle Protractors

- Description: With magnetic base

Item #

GR1895



GREENLEE TEXTRON INC.
Heating Blankets

- Make bends, offsets or saddles in PVC fast and easy
- Easy to use: wrap blanket around PVC, secure with hook and loop strap; built-in stiffeners help keep the blanket tight to the PVC strap; remove blanket and form bend by bend
- Controlled, even heating for uniform bending
- Heavy-duty cord and thermostat for long life
- Temperature over 300°F (149°C)



Item #	Desc.	Capacity
--------	-------	----------

GR860-1[1/2]	For up to 1½ in.	Up to 1½ in. PVC All Schedules
GR860-3	For 2 in. - 3 in.	2 in. - 3 in. PVC All Schedules
GR860-4	For 3½ in. & 4 in.	3½ - 4 in. PVC All Schedules

GREENLEE TEXTRON INC.
Electric PVC Heater/Bender

For 1/2" - 2", All Schedules

- Easy to use: preheat for 10 minutes, insert PVC, rotate until pliable, remove and form bend
- Sturdy double wall metal with fiberglass insulation and reflective interior for fast, even heat
- Full length door for easy PVC loading and removal
- Other features include on/off switch, pilot light and carrying handle



Item #

GR849

GREENLEE TEXTRON INC.
PVC Plug Set

- Use with PVC Heating Blankets or Electric Heaters to plug the ends of the PVC being heated; the trapped air will help keep the PVC from collapsing while forming the bend
- Use on Schedule 40 and 80 PVC
- Available in 2" - 4" set or individual sizes 2" - 6"



Item #

GR859-4

GREENLEE TEXTRON INC.
Electric PVC Heater/Bender

For 1/2" - 4", All Schedules

- Electric PVC heater/bender for 1/2" - 4", all schedules
- Full length door for easy loading and unloading
- Sturdy wheels for easy mobility
- Use two units in tandem to heat large sweep bends

Item #

GR851



GREENLEE TEXTRON INC.
Electric PVC Heater/Bender

For 1/2" - 6", All Schedules

- Easy to use: preheat for 10 minutes, open lid and position PVC, close lid, rotate until pliable, open lid, remove PVC and form bend
- 848 model has motorized rotation
- Heavy duty metal construction with reflective interior for fast, efficient heating
- Has heating chart, timer, and on/off switch with indicator light for added convenience
- Double doors with piano hinges allow heating shorter lengths with one door open



Item #

GR848

GREENLEE TEXTRON INC.
Fiberglass Tip Kit

- .175" (4.4 mm) pulling eye repair kit
- Includes (1) pulling eye and adhesive

Item #

GR10565



GREENLEE TEXTRON INC.
Fish Tape

Nylon

- For use with most electrical wire and coaxial cable
- Tensile strength: 250 lbs.
- Reel type: Winder slide
- Winder case, case Dia. 13", case material plastic
- Dia.: 3/16"
- Length: 100'



Item #

GRFTN536-100



GREENLEE TEXTRON INC.

Fish Tapes Oil-Tempered Spring Steel MagnumPro™

- Advanced comfort grip and rugged case design (Patent Pending)
- Superior rapid grip tape payout and rewind (Patent Pending)
- Viewing ports to see amount of tape in case and allow quick debris removal
- Used for general fishing in conduit
- Improved low profile tip for easy fishing through all sizes of conduit
- Available in 50', 65', 125' and 240' lengths
- 1/8", 1/4" and flat steel profiles to accommodate different fishing situations



Item #	Desc.
GRFTS438-65	Steel Fish Tape - 1/8" x 65'
GRRS438-65	Replacement Steel Tape - 65' (No Case)
GRFTS438-125	Steel Fish Tape - 1/8" 125'
GRRS438-125	Replacement Steel Tape - 125' (No Case)
GRFTS438-240	Steel Fish Tape - 1/8" x 240'
GRRS438-240	Replacement Steel Tape - 240' (No Case)
GRFTS438W-100	Steel Fish Tape - 1/4" x 100'

Accessories

GR439-1	12" Flexible Fish Tape Leader
---------	-------------------------------

GREENLEE TEXTRON INC.

Glo Fish Stix

- Luminescent fiberglass stix for better visibility when fishing above dark ceilings, up walls or below raised floors
- Overall Length - 15'
- Section Length - (3) 5 ft. sections



Item #
GR540-12

GREENLEE TEXTRON INC.

Fish Stix EZ Reach™

- High visible green color rods can be easily threaded and seen when working above ceilings, down walls, or under raised floors
- 1/4" diameter fiberglass rods provide added rigidity when multiple sections are connected
- 200 lbs. minimum pulling strength for long lasting durability and peace of mind



Item #	Desc.
GR540-24	24 ft. Kit with Bullet Nose and "J" Hook Threaded Tips

GREENLEE TEXTRON INC.

24' Fish Pole

Push or pull wires over long distances including suspended ceilings, sub-floors, crawl spaces and attics. Non-conductive, high-impact construction for long life.

- Specialized hook can be used to install wires in suspended ceilings
- Collapses to 50" x 2.25" and uses friction-locking system
- Extended length: 24' (7.31m)
- Collapsed length: 50" (1270mm)



Item #
GR10443

GREENLEE TEXTRON INC.

Poly Line

- Use with power fishing systems directly from the container
- Handy reusable plastic dispenser pail with handle keeps the line dry



Item #	Desc.	Weight (lbs.)
GR430	6500'	210
GR431	5200'	240

GREENLEE TEXTRON INC.

Vacuum/Blower Power Fishing System

- Rugged, self-contained unit includes everything you need to blow or vacuum fish line, poly line or measuring tape
- Durable tank and accessory storage box are corrosion and impact resistant polyethylene
- Designed for the job site, 10' (3.05 m) long hose, large heavy-duty wheels and removable accessory box
- Large 11 gallon (41.6 L) tank makes the 690 excellent for vacuuming water and debris



Item #
GR690

GREENLEE TEXTRON INC.

Fish Lines

- Strong, lightweight nylon
- Mildew resistant, can be pulled into the run with the wire to provide a means to add wires later



Item #	Strength (lbs.)	Strength (N)	Length (ft.)	Length (m)
GR595	85	378	2150	655
GR604	85	378	2200	670
GR607	90	400	1350	411



GREENLEE TEXTRON INC.
Power Fishing System
Li'l Fisher™ 390

- Includes only unit and hose
 - 1/2"-2" conduit capacity
- Contains:
- 2150' of fish line
 - 6 pistons - 1/2", 3/4", 1", 1-1/4", 1-1/2", 2"
 - Adjustment nozzle for measuring tape
 - 3 fish line packages 1/2", 3/4", 1"
 - 2 case adapters
 - Accessory container & lid



Item #
GR390

GREENLEE TEXTRON INC.
Blower Power Fishing Systems

Portable

- Powerful, will blow line or measuring tape in up to 6" conduit
- Efficient, includes the Mighty Mouser® blow gun for fast, easy line blowing
- Includes: Blow gun, fishing line, pistons for 1/2" - 4" conduits, adapter cones, flexible hose, hose clamp, storage box, adapter nozzle for tape and line, portable blower, flexible hose
- Capacity: 1/2" - 4" conduit (5" and 6" with optional pistons)



Item #
GR591

GREENLEE TEXTRON INC.
Piston Foam Sets

- Use with blower or vacuum power fishing system to pioneer the line through the conduit run; flexible foam body for an air-tight seal
- Color-coded end disk with embossed size markings for fast, easy selection
- Include Sizes: 1/2", 3/4", 1", 1-1/4", 1-1/2" and 2" EMT, IMC and Rigid



Item #
GRS2613

GREENLEE TEXTRON INC.
Conduit Pistons

- Use with blower or vacuum power fishing system to pioneer the line through the conduit run
- Flexible foam body for an air-tight seal
- Color-coded end disk with embossed size markings for fast, easy selection



Item #	Conduit Size (in.)	Conduit Type	Color
GR609	3/4	All	Green
GR610	1		
GR611	1 1/4	All	Green
GR612	1 1/2	All	Green
GR613	2	All	Green
GR614	2 1/2	IMC, Rigid	Green
GR621	2 1/2	EMT	Yellow
GR615	3	IMC, Rigid	Green
GR622	3	EMT	Yellow
GR616	3 1/2	IMC, Rigid	Green
GR643	3 1/2	EMT	Yellow
GR617	4	IMC, Rigid	Green
GR623	4	EMT	Yellow
GR618	5	All	Green
GR619	6	All	Green

GREENLEE TEXTRON INC.
Cable Feeders

Ultra Cable Feeders™

- Feeds cable at variable speeds to match the speed of cable puller
- Accommodates cable ranging in size up to 3.5" (88.9 mm) in diameter
- Sets up easily and can be operated by just one person
- Dual motors drive each wheel for traction on both sides of the cable
- An optional foot switch is available to control feeding



Specifications:

- Power Supply: 115 VAC, 15 amps, 60 Hz
- Speed: 4-36 feet per minute (1.2-11 meters per minute)
- Maximum Tractive Force: Single Cable - 200 lbs. (.9 kN), All cables - 800 lbs. (3.5 kN)
- Cable Capacity: 8 x 250 MCM (120 mm δ), 6 x 500 MCM (240 mm δ), 5 x 750 MCM (300 mm δ)

Item #
GR6810



GREENLEE TEXTRON INC.

Foot Switch

For Cable Pullers

- Use with 640, 2001, 6001, 6500, or 6800 cable pullers to add foot control
- Foot pressure required to operate



Item #

GR445

GREENLEE TEXTRON INC.

Cable Puller

Ultra Tugger 2

UT-2

Pulling Capabilities:

- 3 x 500 kcmil cable 500' with 2 x 90 deg. bends
- 3 x 500 kcmil cable 250' with 4 x 90 deg. bends
- 8 x 4/0 AWG cable 300' with 3 x 90 deg. bends



Item #

GRUT-2

GREENLEE TEXTRON INC.

Cable Puller

UT-4

- 4,000 lb. pulling force
- Two pulling speeds
- Equipped with pull force gauge and foot switch
- Dedicated pulling motor



Item #

GRUT-4

GREENLEE TEXTRON INC.

Hook-Type Sheaves

- Forged steel closure type hooks with 1" opening
- Maximum Rated Capacity: 8,000 lbs.

Item #	O.D. (in.)	Inside Radius (in.)	Width (in.)
GR8012	12	3 $\frac{3}{8}$	5
GR8018	18	7	6
GR8024	24	9 $\frac{7}{8}$	6 $\frac{1}{2}$



GREENLEE TEXTRON INC.

Cable Puller

Ultra Tugger®

- Ultra Tugger® Cable Puller with Standard Force Gauge, Floor Mount, Versi-Boom™ System and "T" Stand includes Extensions and 3", 3-1/2" & 4" slip-on Couplers, Elbow, Wheeled Carriage, Screw-on Couplers, or Rope.
- Pulls up to 8,000 lbs. Versi-Boom™ System allows you to make versatile and fast set-ups and pull 10' or 20' of extra cable easily. Uses standard 3' rigid steel conduit for boom. Direct gear drive. Lightweight. Portable. Optional deluxe force gauge.
- Drive Motor 1-1/2 Horsepower
- Pulling Force Maximum - 8,000 lbs., Continuous - 6,500 lbs.
- Rated at 32,000 lbs.



Item #

GR6805A

GREENLEE TEXTRON INC.

Adapter Sheaves

Flexible

- Use to attach to the conduit in conjunction with adapter sheave for easier set-ups
- Helps eliminate strain on hangers and boxes
- Maximum Rated Capacity: 6,500 lbs. (28.9 kN)



Item #

GR608

GREENLEE TEXTRON INC.

Feeding Sheaves

- Yoke frame slides into the end of conduit and holds sheave, allowing the cable being fed into the conduit to smoothly roll over the sheave
- 5" wide aluminum alloy sheave with self-lubricating bearings
- Split tube for easy removal after cable is installed



Item #

Desc.

GR441-2	Feeding Sheave for 2" conduit
GR441-3	Feeding Sheave for 3" conduit
GR411-3-1/2	Feeding Sheave for 3 $\frac{1}{2}$ " conduit
GR441-4	Feeding Sheave for 4" conduit



GREENLEE TEXTRON INC.
Feeding Sheaves

Tray-Type

Steel frame easily attaches to cable tray up to 2" thick. Helps roll and guide tray pulls. Make tray pulls easier. 5" wide aluminum alloy sheaves with self lubricating bearings.



Item #	Length (in.)
GR659	22
GR658	12

GREENLEE TEXTRON INC.
Measuring Tape and Dispenser

Conduit

- Fish and measure conduit runs in one operation
- Permanently printed measurements every foot from zero to 3000' (914 m)

Size:

- 3/16" x 3000' (4.8 mm x 914 m)

Capacity:

- 130 Lbs. (578 N) average breaking strength



Item #
GR435

GREENLEE TEXTRON INC.
Conduit Dispenser

- Pay-out dispenser for 435 conduit measuring tape



Item #
GR434

GREENLEE TEXTRON INC.
Rope Stands

- Use to organize and rewind rope
- Welded steel with washer and spring clip to hold rope reel on stand

Item #	Rope Length ft. (m)
GR405	250 (76), 600 (182)
GR654	300 (91), 600 (182)



GREENLEE TEXTRON INC.
Ultra Glider

With Threaded Applicator Kit

- Applies lube more evenly around the cable and more consistently than can be done by hand; this reduces the force required by the cable puller and reduces the chance for damage to the cable
- During a cable pull, the person feeding the cable usually can operate the Ultra Glider, which reduces the need for one person on the job



Item #
GRUG511T

GREENLEE TEXTRON INC.
Cable Pulling Lubricants

Cable-Cream™

- Advanced formula, light yellow cream makes pulling faster and easier
- Compatible with all cable insulation types
- Dries slowly to a thin, non-conductive, non-hardening residue



Item #	Desc.
GRCRM-Q	One Quart Squeeze Bottle (.95 l)
GRCRM-1	One Gallon (3.79 l)
GRCRM-5	5 Gallons (18.93 l)

GREENLEE TEXTRON INC.
Cable Pulling Lubricants

Fiber-Gel™

- Synthetic gel is specially designed for lightweight fast pulling of fiber optic cables; compatible with all cable jackets



Item #	Size
GRFIBR-Q	One Quart Squeeze Bottle
GRFIBR-1	One Gallon

GREENLEE TEXTRON INC.
Rope Clevis

For Flexible Eye Grips

- Removable bolt and rope sheave, removable grip eye bolt
- Select the clevis with a rating that meets or exceeds the cable puller's maximum pulling force
- Removable sheave for rope eye

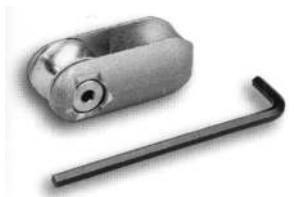

Item #
GR678



GREENLEE TEXTRON INC.

Pulling Grips

Set Screw Clamp

- Pulling Grip with Clevis includes 624S, 624L and 678 clevis - 4 clamp
- Use to pull in 2" (50.8 mm) or larger conduit



Item #

GR629

GREENLEE TEXTRON INC.

Pulling Grips

- Use to pull in 2" or larger conduit
- Type of grip: Flexible eye 1/4" diameter galvanized steel aircraft cable connected to 2 cable receptacles with 5/8" diameter opening and 2 clamping set screws



Item #

GR624

GREENLEE TEXTRON INC.

Pulling Grips

Set Screw Clamp Type

- Use to pull in 2" or larger conduit
- Type of grip: Flexible eye 1/4" diameter galvanized steel aircraft cable connected to a cable receptacle with a 5/8" diameter opening and 2 clamping set screws



Item #

GR504

GREENLEE TEXTRON INC.

Pulling Grips

T-Basket Type

- Use to pull in: conduit or tray
- Type of grip: double weave galvanized steel mesh with flexible pulling eye
- Select the grip with a maximum rated capacity that meets or exceeds the cable puller's maximum pulling force
- Cable Diameter Range: Inch - 1.00 - 1.49 mm - 25.4 - 38.0



Item #

Standard

GR30578

GREENLEE TEXTRON INC.

Pulling Grip Sets

Basket Type

- Basket type pulling grip sets

Item #	Desc.	Capacity
GR30758	Building Wire Junior Grip Set - Diameter Range .25 in. - 1.24 in. (6.4 - 31.5 mm)	(2) #14 to 4 1/0, .25 in. - 1.24 in. (6.4 - 31.5 mm) Diameter
GR597	T-Type Grip Set - Diameter Range .75 in. - 1.99 in. (19 - 50.5 mm)	3-1/0 to 250 MCM, .75 in. - 1.99 in. (1.9 - 50.5 mm) Diameter
GR599	T-Type Grip Set - Diameter Range .75 in. - 2.99 in. (19 - 75.9 mm)	3-1/0 to 3-750 MCM, .75 in. - 2.99 in. (1.9 - 75.9 mm) Diameter



GREENLEE TEXTRON INC.

Battery-Powered CCX Tools

Gator-Pro™

- 360° rotating head adjusts to work position
- Cycles in seconds with two-speed hydraulic pump, maximizing productivity
- Automatic retraction when crimping and cutting cycles are complete
- Uses all optional CCX blades and adapters
- Includes two batteries, a choice of either a 120V, 12V or 230V one-hour charger, and a high-impact molded carrying case



Item # Desc.

GRECCX11 120 V Charger



GREENLEE TEXTRON INC.
Battery-Powered Cable Cutters

Gator-Plus™

- Ram automatically retracts after the cut is complete, no need to push a retract lever
- Two-speed pump advances the ram quickly to start the cut
- Lightweight and easy to use
- Cutting head rotates 360° for making cuts in tight locations, flips open to make mid-span cuts easy
- Cutting Capacity: 2 in. (50 mm) diameter Al or Cu cable



Item #

GRESG50GL11

GREENLEE TEXTRON INC.

Heavy-Duty Cable Cutters

Ratchet

- Ratchet action for heavy-duty cutting
 - Two cutting actions - fast scissor cutting for small cable and insulation; converts automatically to ratchet mode
 - Anti-slip mechanism for positive ratchet action
- Copper Maximum Frequent Use:
- 1500 MCM (800 mm²)
- Aluminum Maximum Frequent Use:
- 1500 MCM (800 mm²)



Item #

GR756

GREENLEE TEXTRON INC.

Cable Cutter

No. 718

- Heat-treated, precision ground, shear action blades
 - Steel handles with rubber grips for leverage
- Copper Maximum Frequent Use:
- 350 MCM (150 mm²)
 - 4/0 (95 mm²)
- Aluminum Maximum Frequent Use:
- 350 MCM (150 mm²)



Item #

GR718

GREENLEE TEXTRON INC.

Cable Cutters



High Performance Ratchet

- Two-speed mechanism saves cutting time by closing the blades rapidly and shifting to normal speed to perform the cut
- Narrow profile permits use in deep boxes, against walls, or on floors
- Maximum Copper Capacity: 750 kcmil (MCM) (400 sq. mm), Frequent use Copper Capacity: 500 kcmil (MCM) (240 sq. mm), Maximum Aluminum Capacity: 795 kcmil (MCM) (400 sq. mm), Frequent use Aluminum Capacity: 750 kcmil (MCM) (400 sq. mm)

Item #

GR774

GREENLEE TEXTRON INC.

Cable Cutter

No. 727



- Heavy-duty forged steel to cut copper or aluminum
 - Heat treated, precision machined, shear action blades
- Capacity:
- Copper
 - Aluminum
- Maximum Frequent Use:
- 2/0 (50 mm²) #1 AWG (35 mm²)
 - 2/0 (50 mm²)

Item #

GR727

GREENLEE TEXTRON INC.

Cable Cutter

Hydraulic



- Flip open head provides strength while making it easy to cut long lengths; head rotates 180°
- Thumb release lever for quick blade retraction
- ACSR: 336.4 kcmil (MCM) Standard Guy Wire, Ground Rod, Rebar: 1/2" (13 mm) Soft Steel Bolts: 11/16" (17 mm) Wire Rope: 3/4" (19 mm)

Item #

GRHK520

**Edge Rents &
Repairs Greenlee
Equipment**



GREENLEE TEXTRON INC.

Cable Cutters **Performance Ratchet**



- Performance ratchet cable cutter
- Simple, one-hand operation
- Two-speed ratchet mechanism adjust for light/heavy cutting
- Well-suited for tight work spaces

Item #	Capacity Copper Maximum	Capacity Aluminum Maximum	Capacity Communications Cable Maximum
GR45206	600 MCM (300 mm \bar{o})	600 MCM (300 mm \bar{o})	1 $\frac{1}{2}$ in. (35 mm) Dia.
GR45207	750 MCM (400 mm \bar{o})	1000 MCM (500 mm \bar{o})	2 in. (50 mm) Dia.

GREENLEE TEXTRON INC.

Compact Ratchet Cable Cutters



- Simple, one-hand operation
- Compact - convenient for working in tight places and stores easily in tool pouches
- Single speed ratchet mechanism
- Blade release allows blades to be opened in mid-cut

Item #	Maximum Copper Capacity	Maximum Aluminum Capacity	Frequent Use Copper Capacity	Frequent Use Aluminum Capacity
GR759	500 kcmil (MCM) (240 sq. mm)	750 kcmil (MCM) (400 sq. mm)	400 kcmil (MCM) (185 sq. mm)	600 kcmil (MCM) (300 sq. mm)

GREENLEE TEXTRON INC.

Cable Cutters **Heavy-Duty**



- Strong, lightweight fiberglass handles
- Adjustable pivot bolt provides for blade adjustment
- Replaceable, forged, heat treated, and precision ground blades

Item #	Desc.	Maximum Copper Capacity	Maximum Aluminum Capacity	Communications Cable
GR704		350 kcmil (MCM) (150 sq. mm)	500 kcmil (MCM) (240 sq. mm)	1 $\frac{1}{4}$ in. (32 mm) Dia.
GR706		750 kcmil (MCM) (400 sq. mm)	1000 kcmil (MCM) (500 sq. mm)	1 $\frac{1}{2}$ in. (38 mm) Dia.
GR22292	706 Cutter Unit (Includes 2 Blades)			

GREENLEE TEXTRON INC.

Battery-Powered Crimping Tools

Gator-Plus™

- Three crimping head choices: EK1230 for industry "U" type dies with 1.20" (30 mm) opening, EK1240 for industry "U" type dies with 1.65" (42 mm) opening, and EK1240K for Kearney PH2 type dies
 - New head designs result in lower weight and improved durability - tested to 50,000 crimp cycles
 - Two-speed pump to reduce cycle time
 - Ram automatically retracts when crimp cycle is complete - a Greenlee exclusive
 - Crimping heads rotate 360°
- Capacity: EK1240K - ASCR terminals 1033 kcmil (MCM), ASCR tension fittings 477 kcmil (MCM), Crimping Force: 106 kN



Item #	Length in. (mm)	Desc.
GREK124011	15 $\frac{1}{4}$ (387)	12-Ton, 1.65 in. (42 mm) Opening, 120 V Charger



GREENLEE TEXTRON INC.

Crimping Tools

Full Cycle Mechanism

- UL classified and CSA certified with Anderson, Blackburn, Burndy, ILSCO, Panduit, Thomas & Betts and Penn-Union copper connectors; crimps all the popular small to mid-range copper connector sizes
- Long length results in low handle efforts
- Color-coded, hexagonal rotating dies
- Capacity: 8 AWG - 4/0 AWG Copper



Item #

GRK09-2SPGL

GREENLEE TEXTRON INC.

Ratchet Cable Bender

- Simplifies and speeds cable installation
- 10" (254 mm) ratchet extension is furnished to simplify bending in deep enclosures
- Includes ratchet wrench, L-wrench, ratchet extension, bending shoe assembly and storage box



Item #

GR796

GREENLEE TEXTRON INC.

Cable Strippers

Adjustable

- For mid-span and end termination; strips TW, THW, THWN, THHN and similar single layer insulation
- Fast-close jaws and twist; quick size and insulation adjustments
- Capacity 1/0 - 1000 kcmil (MCM); insulation rated 600 VAC



Item #

GR1905

GREENLEE TEXTRON INC.

Pocket Cable Strippers

- Stripping tool
- For power and telecommunication cables
- Capacity: 3/16" - 1-1/8" dia. (#8 AWG-600 kcmil (MCM) THHN)



Item #

GR1900

GREENLEE TEXTRON INC.

Non-Contact Voltage Detectors

- Automatic self-test verifies the integrity of the unit
- Bright LEDs and audible alarm sound if voltage is present
- Silent-mode feature for use in quiet settings
- Safe, non-contact voltage detection
- Use to detect voltage in outlets, lighting fixtures, circuit breakers, wires, and cables or to find a break in a wire.
- Automatically turns off after five minutes of non-use to conserve battery life
- Low battery indicator



Specifications:

- Voltage Detection: 50V – 1000VAC
- Frequency: 50-500 Hz
- Measurement Category: CAT IV, 1000V

Item #

GRGT-12

GREENLEE TEXTRON INC.

Digital Multimeter

- Auto and manual ranging
- Non-contact and single-probe voltage detection
- Beep-Jack™ audible and visible warning to guard against improper A and mA terminal plug in
- High visibility 6000 count LCD display
- Capacitance and temperature measurement capability
- Low impedance mode
- AutoCHECK™ feature provides automatic selection of AC volts, DC volts, or resistance with low impedance for ghost-voltage elimination
- True RMS
- Peak (crest) hold; min, max
- Auto power off, display backlight, analog bar graph
- PC interface capability using optional USB RS-232 cable with data recording PC software
- Lifetime Limited Warranty
- Voltage Measurement: 60mV to 1000V AC/DC
- Amperage Measurement: 600mA to 8A AC/DC
- Resistance: 600Ω to 60MΩ
- Frequency (Hz): 50 ~ 400
- Measurement Category: Cat IV 300V; Cat III 600V, Cat II 1000V



Item #

GRDM-510A



GREENLEE TEXTRON INC.
**Ranging Multimeter
Manual**



- Multi-purpose meter for most electrical needs. Includes elastomer boot to protect meter from damage. AC/DC voltage, DC amperage measurement. Temperature measurement. Audible continuity and diode tests. Tests 1.5V and 9V batteries.
- Voltage measurement: AC V: 200.0, 600 V; DC V: 200.0, 2000 mV; 20.00, 200.0, 600V Amperage Measurement: DC A: 20.00, 200.0 mA Temperature measurement: -40 to 1832 F, (-40 to 1000 C) Measurement Category: CAT III, 300V; CAT II, 600V

Item #
GRDM-40

GREENLEE TEXTRON INC.
Clamp-On Meters



- True RMS for the most accurate measurement when harmonics are present
- AC amperage, AC/DC voltage, frequency and resistance measuring capability
- Dual hall sensor for DC amperage accuracy
- Easy to read backlit display for use in low light conditions
- Peak and data hold to capture measurement
- Min/Max feature for added versatility
- Analog bar graph to view quick changes
- Auto zero for DCA measurement
- Amperage Measurement: 400.0; 600 A, Voltage Measurement: 400.0; 600 V, Resistance: 400.0 Ohms, Frequency: 0.400 kHz, Display: 4000 count LCD display, Jaw Opening: 1.38 in. (35 mm), Measurement Category: Cat III; 600 V per UL 3111-1

Item #
GRCM-950

GREENLEE TEXTRON INC.
**Pipe and Wire Locator
Tracker II™**



- Traces the path and determines the depth of wires and metallic pipes on active or dead systems without having to deactivate the system
- Lightweight receiver provides audible and visual indications of signal strength
- Transmitter output and receiver sensitivity are fully adjustable for maximum accuracy
- Transmitter offers three methods of connection: direct, inductive coupler, and inductive antenna
- Includes transmitter assembly, receiver assembly, inductive coupler (clamp), built-in inductive antenna, two 8 ft. (2.4 m) test leads with heavy-duty alligator clips and durable polyethylene case
- High frequency transmitter provides range up to 4,000 ft. (1,219 m) and depths up to 7 ft. (2 m)
- Receiver is 32 in. long (813 mm)
- Battery operated (eight AA and one 9V battery are included)
- Molded carrying case included

Item #
GR501

GREENLEE TEXTRON INC.
Circuit Tracer Kit



- Advanced patented non-directional sensing technology
- Superior sensitivity and functionality providing for accurate tracing and locating
- Ergonomic receiver with information-rich full-color graphical LCD
- Graphics and audible signal provide quick and easy to understand tracing feedback
- Traces concealed wiring, locates junction boxes, and finds breakers for live or open circuits
- Locates and identifies blown fuses
- Finds shorts and breaks in conductors
- Low pitch, high volume audible indicator
- User-selectable automatic or manual gain capability for fast, convenient use
- Power saving features promote extended battery life (Auto Power Off)
- Can be used on GFCI protected circuits
- Supports transmitter-to-receiver distances up to 4 miles for closed circuit tracing
- Does not affect sensitive electronic equipment on the circuit
- Auto backlight on receiver maximizes battery life
- Lifetime Limited Warranty

Operating Conditions:

- Temperature: 0 to +50 °C (32 to 122 °F)
- Altitude: 2000 m (6500') maximum
- Pollution Degree: 2
- Indoor use only

Transmitter:

- Measurement Category: Category III, 750V
- Operating Voltage: 0-750 V AC/DC
- Live line LED indicates voltage above 12 VAC or 5 VDC
- Frequency: 15.15 kHz
- Low battery indicator

Receiver:

- Range from Receiver to item with Signal: Live Line Mode – up to 20 ft (6 m) from circuit, Open Line Mode – Up to 10 ft. (3 m) with a metallic connection to ground, 1 to 3 ft. (.3 to .9 m) with a capacitive ground reference

Item #
GRCS-8000

GREENLEE TEXTRON INC.
Mesh Cabinet



- High-visibility mesh screen on three (3) sides
- Forty-eight (48) smaller, individual compartments, enabling storage of smaller tools and accessories
- 1/2" conduit support tunnels for top storage (conduit not included)
- Supplied with two (2) swivel casters and two (2) rigid 4" (102 mm) casters for easy mobility (Model 696)
- Capacity: 37.3 ft.

Item #
GR5060 MESH



GREENLEE TEXTRON INC.
Handy Caddies

- 3/8" (9.5 mm) diameter solid steel spool support spindles
- Spool retaining washers on spindles
- Holds four 500' (152 m) spools of #10 AWG (7" dia. by 6" - 10" wide)
- Holds up to eight 500' (152 m) spools of #12 AWG (7" dia. x 5" wide)



Item #

GR9502

GREENLEE TEXTRON INC.
Wire Caddies

- 6 wire spool axles with spring clip locks
- Pre-drilled caster mounting holes
- Collapsible wire guide
- Swivel caster set with 2 locking casters for easy use
- Capacity: Six 500' (152.4 m) spools up to 8" (203.2 mm) in diameter of #6 thru #10 AWG 600 volt wire



Item #

GR906

GREENLEE TEXTRON INC.
**Wire Dispenser
No. 909**

- All steel welded frame with 6 reel spindles and feeding eye
- Angled spindles keep reels in place without locks and help brake the reel while paying out
- Mobile, 2 fixed wheels and one that swivels and locks, allow easy movement and control
- Fits through a 30" doorway



Item #

GR909

GREENLEE TEXTRON INC.
Wire Carts

Hand Truck

- Dual heavy-duty wire guides for dispensing multiple wires in all directions
- Only 23" (584.2 mm) wide to fit through narrow doorways
- Comes with five 5/8" (15.9 mm) diameter reel spindles for storing and dispensing up to fifteen spools of #14 THHN wire



Item #

GR38733

GREENLEE TEXTRON INC.

**Wire Dispenser
No. 910**

- Base has 2 fixed and 2 swivel locking heavy duty casters
- The spool rack consists of 10 spindles and an adjustable guide loop, and can be turned 360 degree independent of the base
- Spindles are angled to contain reel reels and act as a brake while paying out wire
- Fits through a 36 inch (915 mm) opening



Item #

GR910

GREENLEE TEXTRON INC.

Wire Utility Cart

- Large capacity, excellent for storing, transporting or feeding wire
- 5 strong reel axles with spring clip retainers plus 2 positions for axle storage allows you to configure for large reels with no loose parts
- Capacity: Size 2,500' (762 m) spools up to 16" (406 mm) in diameter; six 500' (152.4 m) spools up to 8" (203 mm) in diameter



Item #

GR911

GREENLEE TEXTRON INC.

**Storage Rack
Conduit and Pipe**

- 7 individual bins allow you to sort by size and type
- Made of structural square tubing
- Folds down for storage
- Capacity lbs. (kg.): 1000 (454)



Item #

GR668

GREENLEE TEXTRON INC.

**Coiled Cable Dispensers
BX-Armored**

- Dispense armored cable, flexible conduit, Greenfield® or NM-B cable fast and easy without twists or tangles
- Base with adjustable tension control rotates to dispense the cable without overpulling
- Large pulling eye rotates freely and can be used as a carrying handle when the dispenser is empty
- Capacity: One 250' coil or 14/2, 14/3, 12/2 or 12/3 armored cable or romex



Item #

GR37218



GREENLEE TEXTRON INC.
Cable Dispensers

Caddy Basket

- Fits both 2 x 4 and 2 x 6 studs
- Dispense coils of NM-B or armored cable
- Swivel eyelet eliminates tangles



Item #	Desc.
GR9525F	Folding Stud Mount Caddy

GREENLEE TEXTRON INC.
Reel Stands

Screw Type

- Wide welded steel base for added stability
- Roller bearings fit in the spindle groove to keep the spindle in place and turning freely
- Two stands and a spindle are required for a complete set-up



Item #	Desc.	Capacity
GR683	Reel Stand 22 in. - 54 in.	2,500 lbs. each, 46 in. - 96 in. Reel Diameter
GR687	Reel Stand 13 in. - 28 in.	2,500 lbs. each, 28 in. - 56 in. Reel Diameter

GREENLEE TEXTRON INC.
Reel Stand Spindles

- Tempered steel with grooves to fit reel stand rollers



Item #	Desc.
GR647	Spindle for 687 Reel Stands
GR657	Spindle for 656 Reel Stands
GR684	Spindle for 683 Reel Stands

GREENLEE TEXTRON INC.
Threaded Rod Cutter

- One stroke cuts through threaded rod; cuts clean, eliminating the need to grind or file before threading a nut onto a cut end
- Strong forged steel cutting head with tool steel cutting die for long life
- Capacity: 1/4" - 20 soft steel rod; 3/8" - 16 soft steel rods



Item #
GR36587

GREENLEE TEXTRON INC.
Hydraulic Pump

Electric

- Usable oil volume: 6 quarts (5.7 liters)
- For use with all Greenlee benders
- Handy pendant advance control
- Automatic or manual ram return selector valve provides more control from the pendant switch
- Capacity: 10,000 PSI



Item #
GR980

GREENLEE TEXTRON INC.
Hydraulic Oils

- Greenlee-approved
- Specially compounded for use with Greenlee hydraulic equipment

Item #	Size
GR4016GB	1 g (3.8 l)
GR4017GB	1 qt (.9 l)



GREENLEE TEXTRON INC.
Conduit Cutters

BX and Flexible

- Use With AC and MC Cable up to 1"
- Adjustable up to 1" outside diameter
- Cuts in seconds with a few quick turns of the crank and an easy twist of the armor
- Convenient under-handle blade storage holds spare blades
- Quick load clamp system makes repeat cuts fast and easy



Item #
GR0952-01
GR1941-1

• Want a complete Greenlee catalog?
• Call Edge today for more detailed product literature.



GARDNER BENDER
Conduit Hand Bender
Big Ben™



- Embossed sight lines for 10°, 22°, 30°, 45°, 60° and 90°
- Industry-standard markings – 30° bend when handle is straight up
- Bigger hook with a 5x durability factor
- Bigger foot pedal – 40% larger
- Bend-back channel easily corrects conduit over-bends
- Rugged heat-treated aluminum head and steel handle

Item #	Bend Radius (in.)	EMT Size (in.)	Rigid Size (in.)
GB960H	3.69	½	-
GB961H	4.74	¾	½
GB962H	5.81	1	¾

GARDNER BENDER
**Electric-Powered
Jobsite Bender**
Cyclone™



- Ability to make repeatable bends at the same degree
- Horizontal and vertical positions allow the unit to create accurate offset bends
- Low-volt (95), high-volt (132) automatic shut-off helps protect electrical components from voltage fluctuations
- On/Off switch allows user to shut machine down for extended periods of time
- Hook attachment on pendant control frees hands while working with conduit
- 110/115 V AC, 15 AMP 1 HP DC Motor
- Bends - Rigid, EMT, Rigid aluminum, IMC, PVC-coated rigid (1/2" to 1-1/2")

Item #
GBB2000

GARDNER BENDER
Powered Puller (Tugger)
Brutus™



- Pulls up to 8000 lbs.
- Exclusive planetary gear design lets powerhead deliver smooth, sure power without breakage
- Powerful 1-1/2 hp motor starts under full load; capstan is non-reversing with backstop brake - will not reverse when power is shut off
- Two-way power head mounting adapts to tight corners
- Pulls 10 feet/minute without buckling or bending
- Frame assembles in numerous configurations
- Versatile frame mounts power head almost anywhere
- Heavy-duty metal case included
- Min 15 A, Max 30 A

Item #
GBCP8000

GARDNER BENDER
**Hydraulic
Knockout Set**
Slug-Out™



- Punches holes for 1/2" to 4" conduit in distribution boxes, electrical panels or troughs
- Four point design allows slug to drop automatically without splitting
- Punches up to 10-gauge mild steel and 12-gauge stainless steel
- Hand-powered hydraulic pump
- Includes metal storage case
- Other punches and dies are interchangeable

Item #
GBKOH540A

GARDNER BENDER
**Ratchet Wrench
Knockout Set**
Slug-Out™



- 1/2" to 2" conduit size
- Four-point design allows slug to drop automatically without splitting
- Punches up to 10-gauge mild steel and 12-gauge stainless steel
- Set includes ratchet wrench, six sizes of punches and dies, and two drive screws all packaged in a rugged storage case

Item #
GBKOW520

GARDNER BENDER
Hook-Type Sheaves



- Keeps cable together for easier manageability and enables direction of cable to be changed
- Sheave made of rugged aluminum alloy
- Hook frame made of welded steel
- Rated at 8,000 lb. capacity

Item #	Width (in.)	Diameter (in.)
GBHS-8524	5	24

GARDNER BENDER
Fish Tapes
UpperHand™



- Ergonomic handle reduces wrist strain
- Comfort formed grip reduces forearm strain
- Cushioned rubber hand grips for ease of operation and comfort
- Impact modified handle and housing that exceeds the 25 ft. drop-test
- Corrosion-resistant plated carbon steel wire

Item #	Length (ft.)	Internal / External Ring Dia (in.)
GBFTS65R	65	4/8[1/2]
GBFTS125R	125	5½/12
GBFTS250	250	5½/12



CURRENT TOOLS, INC.

Hook-Type Sheaves

8,000 lb. Capacity



Item #	Desc.
CT812	12" Diameter HD hook sheave
CT818	18" Diameter HD hook sheave

CURRENT TOOLS, INC.

Radius-Type Sheaves

4,000 lbs. Capacity



- Aluminum sheaves 5" wide

Item #	Desc.
CT12036	36" Radius Sheaves with 9 Sheaves

CURRENT TOOLS, INC.

Tray-Type Sheaves

- 5" aluminum sheave with self lubricating bearings



Item #	Desc.
CT951TR	Small Tray-Type Sheave/12" Long



BURNDY

Dies

- U-dies for grounding applications
- Single and twin crimp styles



Item #
BUPU998
BUU1011
BUU997

BURNDY

Battery Actuated Crimps

Battery actuated 12 ton crimp tool with covered head, (2) 18 volt Li-ion batteries, 120 V-AC charger, lanyard and carry case.



Item #
BUPAT750C-LI

BURNDY U Die Kits



- Each UDIEKITCU and UDIEKITAL die kit includes 15 sets of "U" dies and the PT29291 die case. These stainless steel color coded dies are for crimping BURNDY YA, YS, YA-A, and YS-A type HYLUG and HYLINK color coded terminals and splices ranging from #6 AWG through 750 kcmil.
- The UDIEKITHYGRD kit includes eight die sets. Seven die sets are used to install the BURNDY HYGROUND irreversible compression grounding connectors, & the U2CABT die set for pre-criming 1/2", 5/8", and 3/4" ground rods for increased rotational resistance.
- BURNDY "U" dies are used in the Y35, Y39, Y750 series, PAT750-18V series, Y46, and PAT46-18V (with PUADP-1 adapter) tools.

Item #	Wire Size
--------	-----------

BUUDIEKITHYGRD Includes

BUUC
BUUO
BUU997
BUPU998
BUU1011
BUU1104
BUU1105
BUU2CABT
BUPT29291

BUUDIEKITCU Includes

BUU5CRT	#6 AWG
BUU4CRT	#4 AWG
BUU2CRT	#2 AWG
BUU1CRT-1	#1 AWG
BUU25RT	1/0 AWG
BUU26RT	2/0 AWG
BUU27RT	3/0 AWG
BUU28RT	4/0 AWG
BUU29RT	250 kcmil
BUU30RT	300 kcmil
BUU31RT	350 kcmil
BUU32RT	400 kcmil
BUU34RT	500 kcmil
BUU36RT	600 kcmil
BUU39RT	750 kcmil
BUPT29291	Die Cast

BUUDIEKITAL Includes

BUU6CABT	#6 AWG
BUU4CABT	#4 AWG
BUU2CABT	#2 AWG
BUU1CART	#1 AWG
BUU25ART	1/0 AWG
BUU26ART	2/0 AWG
BUU27ART	3/0 AWG
BUU28ART	4/0 AWG
BUU29ART	250 kcmil
BUU30ART	300 kcmil
BUU31ART	350 kcmil
BUU32ART	400 kcmil
BUU34ART	500 kcmil
BUU36ART	600 kcmil
BUU39ART-2	750 kcmil
BUPT29291	Die Cast



BURNDY

Battery Actuated Crimps

Battery actuated 11 ton dieless crimp tool with (2) 18 Volt Li-ion batteries, 120 V-AC charger, lanyard and carry case.

Item #

BUPAT644-LI



BURNDY

Battery Actuated Crimps

Battery actuated 15 ton crimp tool with covered head, (2) 18 Volt Li-ion batteries, 120 V-AC charger, lanyard and carry case.

Item #

BUPAT46C-LI



BURNDY

Hydraulic Dieless Crimper

18 Volt
Patriot®

- True, one-handed operation for advance, retract, and hold
- 11-ton output force
- State of the art crimping head design, 360° head rotation
- Audible “pop-off” and Green indicator indicates properly completed crimps
- Ergonomically balanced tool design
- Durable high impact formed carrying case

Item #

BUPAT644XT18V



BURNDY

Hydraulic Dieless Crimper

18 Volt
Patriot®

- Dieless installation system
- UL Listed and CSA Certified with Range Taking Capabilities
- 6 tons output force
- Audible pressure “pop-off” valve and die embossment providing 360° inspectability
- Ergonomic design allows one hand operation for ram advance and ram retraction
- 360° head rotation
- Ram holds position when trigger is released

Item #

BUPAT81KFT18V



BURNDY

Hydraulic Crimper

18 Volt
Patriot®

- True, one-handed operation for advance, retract, and hold
- 12-ton output force
- State of the art crimping head design, 360° head rotation
- Audible “pop-off” and Green indicator indicates properly completed crimps
- Ergonomically balanced tool design
- Durable high impact formed carrying case

Item #

BUPAT750XT18V



BURNDY

Hydraulic Self-Contained Cutter

18 Volt
Patriot®

- Advance design high-speed pump completes tough cuts faster
- Ergonomic design allows one hand operation
- 180° head rotation
- Mechanical ram release
- Operates on 18 volt Ni-MH batteries
- Durable high impact formed carrying case
- Capable of cutting up to 1.29” diameter copper and aluminum cable, 1113 ACSR, 5/8” ground rod, 1/2” rebar, 5/8” diameter soft steel bolts, up to 1/2” standard guy strand, and up to 3/8” EHS guy strand

Item #

BUPATCUT129ACSR18V



BURNDY

Hydraulic Self-Contained Cutter

18 Volt
Patriot®

- Advance design high-speed pump completes tough cuts faster
- Ergonomic design allows one hand operation
- 180° head rotation
- Mechanical ram release
- Operates on 18 volt Ni-MH batteries
- Durable high impact formed carrying case
- Capable of cutting up to 2.45” diameter copper and aluminum cable. Do not use to cut steel, ground rod, rebar or guy wire

Item #

BUPATCUT245CUAL18V



CADWELD® & Grounding Products

CADWELD® Products



Handle
Clamp



Control Unit

CADWELD® Plus



CADWELD®
Mold



CADWELD® Multi



Flint Ignitor



CADWELD®
Welding Material



CADWELD®
One Shot

CADWELD® Connections



VS



GR



GT



LA



GY



XA

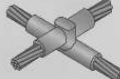

XB



TA



PC



SS



NC

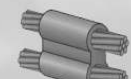

PT

Ground Rods

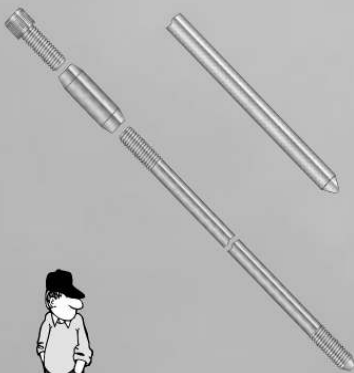

Grounding Products

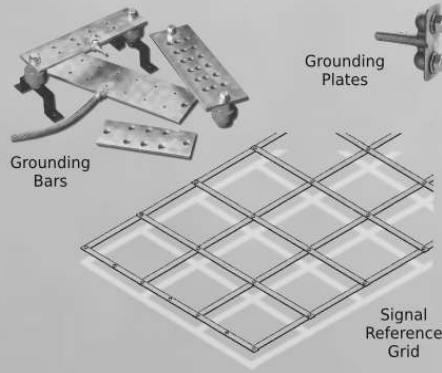

GEM



Ground
Enhancement
Material



ERICO/CADDY
GY Mold
Cadweld



- The two-piece GY mold lets you make connections in a trench in about half the time it would take with compression connections or other exothermic connections and at a fraction of the cost
- Ergonomic two-piece molds use standard L160 and L159 handle clamps—the same clamps you use with other Cadweld® molds
- Saves labor costs; a GY connection can be made by one person in about one minute—much faster than other methods
- Includes a new baffle mold cover which reduces emissions and extends the handle clamp life
- Available with wear plates

Item #	Mold Part Number	Copper Clad Ground Rod (Run) (in.)	Conductor Size (Tap)
CD115PLUSF20	GY R142C	1/2	1/0 CONC
CD115PLUSF20	GY R142G	1/2	2/0 CONC
CD150PLUSF20	GY R142L	1/2	3/0 CONC
CD150PLUSF20	GY R142Q	1/2	4/0 CONC
CD150PLUSF20	GY R142V	1/2	250 CONC
CD90PLUSF20	GY R161T	5/8	2 SOL
CD90PLUSF20	GY R161V	5/8	2 CONC
CD115PLUSF20	GY R162C	5/8	1/0 CONC
CD115PLUSF20	GY R162G	5/8	2/0 CONC
CD150PLUSF20	GY R162L	5/8	3/0 CONC
CD150PLUSF20	GY R162Q	5/8	4/0 CONC
CD150PLUSF20	GY R162V	5/8	250 CONC
CD250PLUSF20	GY R163D	5/8	350 CONC
CD400PLUSF20	GY F163Q	5/8	500 CONC
CD90PLUSF20	GY R181T	3/4	2 SOL
CD90PLUSF20	GY R181V	3/4	2 CONC
CD115PLUSF20	GY R182C	3/4	1/0 CONC
CD115PLUSF20	GY R182G	3/4	2/0 CONC
CD150PLUSF20	GY R182L	3/4	3/0 CONC
CD150PLUSF20	GY R182Q	3/4	4/0 CONC
CD200PLUSF20	GY R182V	3/4	250 CONC
CD300PLUSF20	GY R283D	3/4	350 CONC
CD500PLUSF20	GY F183Q	3/4	500 CONC

ERICO/CADDY
TA Connection
Cadweld

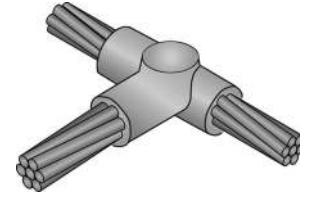

- Connection Type: TA
- Mold Family: Cable to cable
- Mold Type: Standard mold
- Ease of Use: Preferred

Item #	Run Family	Run Size	Tap Family	Tap Size
CDTAC-2S1K	Copper Ropelay	4/0 Ropelay	Copper Solid	#4 Solid
CDTAC-4L2Q	Copper Concentric	750 KCM Concentric	Copper Concentric	4/0 Concentric
CDTAC-9J9J	Copperweld-Stranded	19/#6 Copperweld	Copperweld-Stranded	19/#6 Copperweld

ERICO/CADDY
Lug
Cadweld

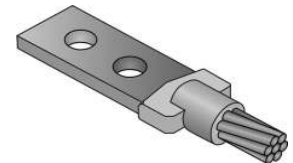

- Cable to lug or bus bar

Item #	Run Size (in.)	Tap Size
CDLAC-2QEK	1/4 x 3 Lug/Bus	4/0 Concentric
CDLAC-3QEH	1/4 x 2 Lug/Bus	500 KCM Concentric

ERICO/CADDY
Weld Metals



CADWELD Weld Metal is a mixture of copper oxide and aluminum, packaged by size in plastic tubes. Each tube contains the starting material at the bottom of the plastic tube, with the weld metal on top. These materials are not explosive and not subject to spontaneous ignition. These containers are packaged in boxes along with metal disks. Each weld uses one disk.

Weld Metal are used for grounding connections: F20 or standard weld metal is used for all grounding connections with the exception of those to cast iron or to load bearing rail. The standard weld metal containers have clear (or natural) caps. Standard weld metal is also used with most FX molds.

- Package: Foil pouch

Item #
CD25
CD32
CD45
CD65
CD90
CD115
CD150
CD200
CD250
CD500

ERICO

ERICO/CADDY Ground Rods

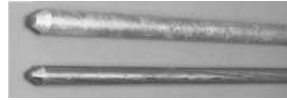

Item #	Description
CD815880	5/8"x8' Galvanized Steel
CD613480	3/4"x 8' Copper Clad

ERICO/CADDY Weld Metals



- The CADWELD PLUS System offers all the benefits of conventional CADWELD connections
- Consists of a tamper proof, disposable, moisture resistant welding material cup. The welding material, disk and ignition source are incorporated into the self-contained package
- Color coded welding material reduces risk of misapplication and gives a simple visual verification of the correct welding material size
- Electronic Control Unit means no starting material is required and makes ignition very easy
- Six foot control unit lead gives increased flexibility in hard to reach areas

Item #
CD25PLUSF20
CD32PLUSF20
CD45PLUSF20
CD65PLUSF20
CD90PLUSF20
CD115PLUSF20
CD150PLUSF20
CD200PLUSF20
CD250PLUSF20

ERICO/CADDY 3/4 Ground Rod

3/4" Cooper Bonded Rod Cadweld

- Cable to ground rods or other rounds

Item #	Cable	Weld Metal
CDGRC-182Q	4/0	#90

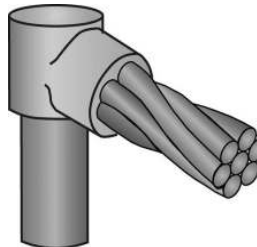

ERICO/CADDY 5/8 Ground Rod

Cadweld

- Cable to ground rods or other rounds

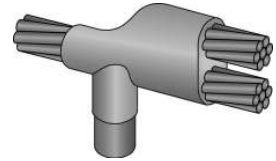

Item #	Cable	Weld Metal
CDNCR-162G	2/0	#200

ERICO/CADDY Ground Rod Cables

One-Shot™

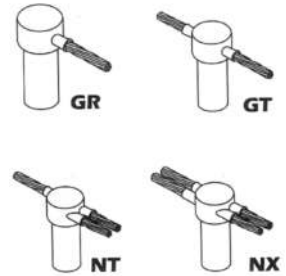

Item #	Conductor Solid	Conductor Stranded	Rod Size (in.)	UoM
CDGT1-161V	1,2	2,3	5/8	Ea
CDNT1-161V	1,2	2,3	5/8	Ea

ERICO/CADDY Ground Rod Cables

- Through cable to top of ground rod
- Connections are for concentric strand copper cable unless otherwise noted

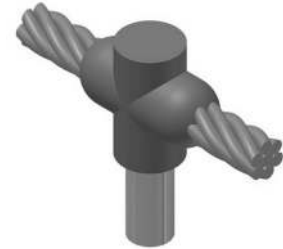

Item #	Ground Rod Size (in.)	Cable Size	Weld Metal
CDGTC-161T	5/8	2 SOL	90
CDGTC-161V	5/8	2	90
CDGTC-162G	5/8	2/0	115
CDGTC-162Q	5/8	4/0	115
CDGTC-182Q	3/4	4/0	115

5/8 in. Ground Rod Size

3/4 in. Ground Rod Size

ERICO/CADDY Cable Cleaning Brushes

- Card cloth brush

Item #
CDT313

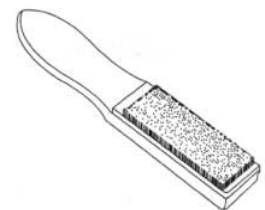

ERICO®

ERICO/CADDY **Mold Sealers**

- Cadweld Mold Sealer is ideal for sealing hot or cold molds to retard leakage from large stranded conductors

Item #
CDT403



ERICO/CADDY **Handle Clamps**

- For C price key molds

Item #
CDL-160



ERICO/CADDY **Flint Igniters**

Cadweld flint igniters are used to ignite the starting material when making a Cadweld connection. An ignitor is included with each handle clamp or frame. T320A Replacement flints are also available.

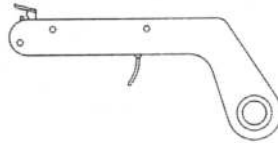

Item #	Desc.
CDT320	Flint Igniter
CDT320A	Repl. Flints

ERICO/CADDY **Cable Cleaning Brushes**

- Cable cleaning brush cleans any conductor and is especially useful for coarse or very dirty conductors

Item #
CDT-314

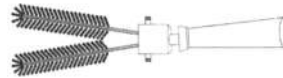

ERICO/CADDY **Mold Cleaning Brushes**

- Mold cleaning brush is very useful for removing slag from molds - especially vertical split molds

Item #
CDT394

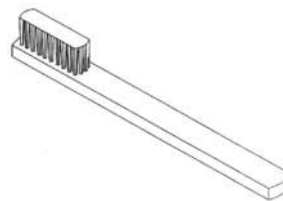

ERICO/CADDY **Parallel Horizontal Conductors**

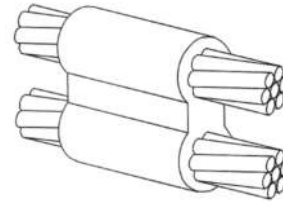

- Parallel through connection of horizontal cables

Item #	Cable Size Run	Cable Size Tap	Weld Metal
CDPTC-1T1T	2 SOL	65	

ERICO/CADDY **Horizontal Tee Cables**

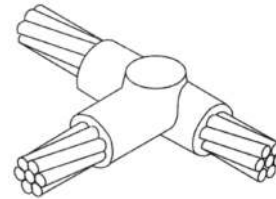

- Tee of horizontal run and tap cables

Item #	Cable Size Run	Cable Size Tap	Weld Metal
CDTAC-1T1T	2 SOL	45	Ea
CDTAC-1V1L	2	4	45
CDTAC-2C2C	1/0	90	Ea
CDTAC-2G2G	2/0	90	Ea
CDTAC-2Q2Q	4/0	150	Ea
CDTAC-2Q2G	4/0	2/0	90
CDTAC-2V2G	250	2/0	90

ERICO/CADDY **Horizontal X Cables**

- Cross of horizontal cables, tap cable cut-cables in same plane

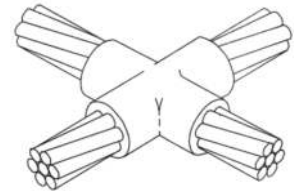

Item #	Cable Size Run	Cable Size Tap	Weld Metal
CDXAC-2Q2Q	4/0	200	

ERICO/CADDY **Horizontal Splices**

- Splice of horizontal cables

Item #	Cable Size	Weld Metal
CDSSC-2G	2/0	65
CDSSC-2L	3/0	90
CDSSC-2Q	4/0	90

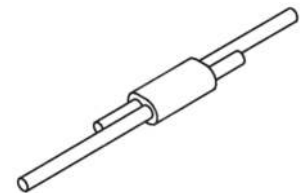

ERICO®

ERICO/CADDY
Cadweld® Plus

Ignitor Control Unit
Cadweld



Item #

CDPLUSCU

ERICO/CADDY
VF Connector

Cadweld

- Cable to steel or pipe

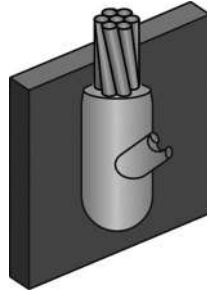

Item #	Cable Size	Pipe Size (in.)	Weld Metal
CDVFC-1T-V3C	#2 sol.	2 - 4	#65

ERICO/CADDY
VS Connector

Cadweld

- Cable to steel or pipe

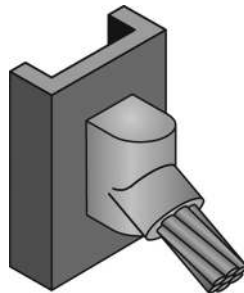

Item #	Cable Size	Pipe Size (in.)	Weld Metal
CDVSC-1T	#2 sol.		#45
CDVSC-1T-V3C	#2 sol.	1½ - 4	#45
CDVSC-2G	2/0		#90
CDVSC-2L-V3C	3/0	2 - 4	#115
CDVSC-2Q	4/0		#115
CDVSC-3Q	500		#200

ERICO/CADDY
XA Connector

Cadweld

- Cable to cable

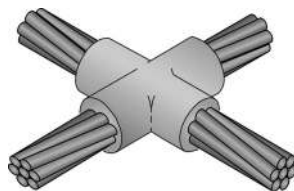

Item #	Run Size	Tap Size	Weld Metal
CDXAC-2L2L	3/0	#150	

Need help with your ground solution? Call Edge today to:

- Get recommendations
- Arrange a demo
- Get more detailed specifications
- Get a quote
- Have one of our sales reps look at your plans and specifications

Have you considered:

- Grounding rods
- Brush, file, and cleaning tools
- Safety glasses
- Gloves
- Cable cutters



ERICO/CADDY
Cadweld® Plus One Shot

**Single-use
Cadweld**



- Easy-to-use electronic ignition; no starting material
- Durable disposable ceramic body eliminates the graphite mold and frame
- The Cadweld® Plus One Shot is ideal for making permanent reliable connections to ground rods for electrical transmission and distribution, telecommunications and cable television applications

Item #	Ground Rod Size (in.)	Concentric Conductor SOL	Concentric Conductor STR	Metric Conductor (sq. mm)
Type: GR				
CDGR1141GPLUS	1/2	6, 8	8	8-10
CDGR1141LPLUS	1/2	3, 4	4, 6	14-22
CDGR1141VPLUS	1/2	1, 2	2, 3	30-38
CDGR1161GPLUS	5/8	6, 8	8	8-10
CDGR1161LPLUS	5/8	3, 4	4, 6	14-22
CDGR1161LPLUS	5/8	1, 2	2, 3	30-38
CDGR1162CPLUS	5/8	2/0, 1/0	1/0, 1	50-60
CDGR1162GPLUS	5/8		2/0	70
CDGR1162QPLUS	5/8		4/0	
CDGR1181GPLUS	3/4	6, 8	8	8-10
CDGR1181LPLUS	3/4	3, 4	4, 6	14-22
CDGR1181VPLUS	3/4	1, 2	2, 3	30-38
CDGR1182CPLUS	3/4	2/0, 1/0	1/0, 1	50-60
CDGR1182GPLUS	3/4		2/0	70
CDGR1182QPLUS	3/4		4/0	
Type: GT				
CDGT1141GPLUS	1/2	6, 8	8	8-10
CDGT1141LPLUS	1/2	3, 4	4, 6	14-22
CDGT1141VPLUS	1/2	1, 2	2, 3	30-38
CDGT1161GPLUS	5/8	6, 8	8	8-10
CDGT1161LPLUS	5/8	3, 4	4, 6	14-22
CDGT1161VPLUS	5/8	1, 2	2, 3	30-38
CDGT1162CPLUS	5/8	2/0, 1/0	1/0, 1	50-60
CDGT1162GPLUS	5/8		2/0	70
CDGT1181GPLUS	3/4	6, 8	8	8-10
CDGT1181LPLUS	3/4	3, 4	4, 6	14-22
CDGT1181LPLUS	3/4	1, 2	2, 3	30-38
CDGT1182CPLUS	3/4	2/0, 1/0	1/0, 1	50-60
CDGT1182GPLUS	3/4		2/0	70
Type: NT				
CDNT1141GPLUS	1/2	6, 8	8	8-10
CDNT1141LPLUS	1/2	3, 4	4, 6	14-22
CDNT1141VPLUS	1/2	1, 2	2, 3	30-38
CDNT1161GPLUS	5/8	6, 8	8	8-10
CDNT1161LPLUS	5/8	3, 4	4, 6	14-22
CDNT1161VPLUS	5/8	1, 2	2, 3	30-38
CDNT1181GPLUS	3/4	6, 8	8	8-10
CDNT1181LPLUS	3/4	3, 4	4, 6	14-22
CDNT1181VPLUS	3/4	1, 2	2, 3	30-38

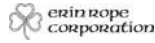

ERIN ROPE CORPORATION
Pulling Rope

Composite Double Braid

- High tensile low stretch polyester double braided pulling rope with factory spliced pulling eyes at each end
- Items listed are 600' (also available in 1200')



Item #	Dia (in.)	Min. Break Strength (lbs.)
ERCDB160600	1/2	9,500
ERCDB240600	3/4	26,000
ERCDB280600	7/8	32,000

ERIN ROPE CORPORATION
Manila Rope

3 Strand Natural Fiber

- The strongest of all natural fiber ropes
- Premium grade with 36 minimum becker value
- Items listed are 600' (additional lengths available)



Item #	Dia (in.)	Min. Break Strength (lbs.)
ERTWM160600	1/2	2,385
ERTWM200600	5/8	3,960

ERIN ROPE CORPORATION
Premium Braided Nylon Twine

Mason Line

- High quality braided twine, will not unravel after multiple uses
- Size - #18, Length 1000'
- Min. Break Strength 157 lbs.



Item #	Color
ERBSTFG1000	Fluorescent Green
ERBSTFO1000	Fluorescent Orange
ERBSTFP1000	Fluorescent Pink
ERBSTFY1000	Fluorescent Yellow

ERIN ROPE CORPORATION
Pulling Tapes

Woven Polyester

- Low stretch, high strength, sequentially footage marked pulling tape
- Measure and pull with same product



Item #	Width (in.)	Approx. Tensile Strength (lbs.)	Length (ft.)
ERWP12503000	1/2	1250	3,000
ERWP18003000	5/8	1800	3,000
ERWP25003000	3/4	2500	3,000

ERIN ROPE CORPORATION
Conduit Measuring Tape

- Sequential footage marks from 1-3,000 ft.
- Allows for fishing and measuring conduit runs in one easy step



Item #	Width (in.)	Min. Tensile Strength (lbs.)	Length (ft.)
ERPCMT3000	1/4	130	3,000



KLEIN TOOLS

Ironworkers Pliers

- Standard side cutters for rebar work
- Specially designed and sharpened for cutting soft annealed tie wire
- Special, heavy, knurled jaws
- Hook bend in one handle for non-slip grip
- Coil spring holds jaws open
- Plastic-dipped handles



Item #	Overall Length (in.)	Jaw Length (in.)	Jaw Width (in.)	Jaw Thickness (in.)	Knife Length (in.)
KLD2000-7CST	9 1/4	1 1/32	1 1/32	1/2	5/8
KLD201-7CST	8 3/4	1 1/32	1 1/32	1/2	5/8



KLEIN TOOLS

High-Leverage Side-Cutting Pliers

- Quickly and easily pulls 1/8" or 1/4" flat steel fish tape
- High-leverage design
- Streamlined design with cross-hatchet knurled jaws
- NE New England nose design
- Plastic-dipped handles



Item #	Overall Length (in.)	Jaw Length (in.)	Jaw Width (in.)	Jaw Thickness (in.)
KLD213-9NETP	9 ³ / ₈	1 ¹⁹ / ₃₂	1 ¹ / ₄	5 ¹ / ₈

KLEIN TOOLS

High-Leverage Side-Cutting Pliers

- These pliers provide a 46% greater mechanical advantage than regular 9-1/4" side cutters
- Plastic-dipped handle
- Overall length 9-3/8 inches



Item #	Knife length (in.)	Jaw thickness (in.)	Jaw width (in.)	Jaw length (in.)
KLD213-9	25/32	5/8	1-1/4	1-19/32

KLEIN TOOLS

End-Cutting Pliers

- For cutting wire or nails close to the work
- With wide throat clearance, ample handle leverage, jaws at just the right angle for easy cutting; makes a clean, even cut
- Plastic-dipped handles
- Overall length: 8-1/2"



Item #	Knife length (in.)	Jaw thickness (in.)	Jaw width (in.)	Jaw length (in.)
KLD232-8	1-3/16	19/32	1-3/16	3/8"

KLEIN TOOLS

High Leverage Ironworker's Pliers

- For easier cutting of soft annealed tie wire
- Knurled jaws
- With coil spring
- Hook bend in one handle for non-slip grip
- Plastic-dipped handles



Item #	Overall Length (in.)	Jaw Length (in.)	Jaw/Width (in.)
KLD213-9ST	9 ³ / ₈	1 ¹⁹ / ₃₂	1 ¹ / ₄
KLD2000-9ST	9 ³ / ₈	1 ¹⁹ / ₃₂	1 ¹ / ₄

Journeyman™ Series

KLJ2000-9ST	9 ³ / ₈	1 ¹⁹ / ₃₂	1 ¹ / ₄
-------------	-------------------------------	---------------------------------	-------------------------------

KLEIN TOOLS

Long-Nose Pliers

Standard-Duty

- With side cutters
- Long-nose design with cutting knives at hinge
- Permits wrapping, looping and cutting with a single pliers
- Plastic-dipped handles



Item #	Overall Length in.	Jaw Length in.	Point Thickness in.
KLD203-5	5 ⁹ / ₁₆	1 ⁹ / ₁₆	3/32
KLD203-6	6 ⁵ / ₈	1 ¹⁵ / ₁₆	3/32
KLD203-7	7 ¹ / ₈	2 ⁷ / ₁₆	3/32

KLEIN TOOLS

Long-Nose Pliers

High-Leverage

Journeyman™

- Soft material on outer surface for comfort and a firm grip
- Hard, black material for toughness and durability
- Contoured thumb area for additional comfort and positive feel
- Color-coded yellow, dark blue, red, or light blue handles allow quick identification of the tool
- Induction hardened cutting knives for long life
- Heavier design for greater cutting power
- Extended handles provide added reach and leverage
- Slim head design for working in confined areas
- Overall Length: 8-9/16"
- Jaw Length: 2-5/16"
- Jaw Width: 1"
- Jaw Thickness: 1/2"
- Knife Length: 5/8"
- Point Thickness: 1/8"



Item #
KLJ203-8

KLEIN TOOLS

Long-Nose Pliers

Heavy-Duty

- With side cutters, skinning hole for No. 12 AWG insulated wire and crimping die for connectors, lugs and terminals
- Comfortable plastic-dipped handles
- Overall length: 8-5/8" (211 mm), jaw length: 2-5/16" (59 mm), jaw width: 1" (25 mm), jaw thickness: 1/2" (13 mm), knife length: 5/8" (16 mm), point thickness: 1/8" (3 mm)



Item #
KLD203-8NCR



KLEIN TOOLS
Long-Nose Pliers

Heavy-Duty

With Side Cutters and Skinning Hole

- With side cutters
- With skinning hole for No. 12 AWG insulated wire
- Plastic-dipped handles
- Overall Length: 8-7/16"
- Jaw Length: 2-5/16"
- Jaw Width: 1"
- Jaw Thickness: 1/2"
- Knife Length: 5/8"
- Point Thickness: 1/8"



Item #	Overall Length (in.)
KLD203-8	8 ⁷ / ₁₆
KLD203-8N	8 ⁷ / ₁₆

KLEIN TOOLS

Slip-Joint Pliers

- Nickel-chrome plated with knurled handles
- Have shear-type wire cutter and two jaw positions
- Plastic coated handles



Item #	Overall Length in.	Jaw Length in.	Jaw Width in.	Jaw Thickness in.
KLD511-6	6	1 ³ / ₃₂	1 ³ / ₁₆	1 ³ / ₃₂
KLD511-8	8	1 ⁵ / ₁₆	1 ¹ / ₄	7/ ₁₆

KLEIN TOOLS

Slim Long-Nose Pliers

- Needle tip only 1/32" in diameter for precise assembly work
- Side cutters permit bending, forming and cutting with a single plier
- Knurled jaws
- With coil spring
- Plastic-dipped handles



Item #	Length (in.)	Jaw Length (in.)	Jaw
KLD221-5 1/2C	5 ⁵ / ₁₆	1 ³ / ₄	5/ ₁₆

KLEIN TOOLS

High Leverage Side-Cutting Pliers

- Smooth, streamlined nose with knurled jaws
- High-leverage design provides 46% greater cutting and gripping power
- Plastic-dipped handles
- Nose Type: New England
- Jaw thickness: 5/8"
- Knife length: 25/32"



Item #	OA Length (in.)	Jaw Length (in.)	Jaw Width (in.)
KLD213-8NE	8 ¹ / ₂	1 ⁷ / ₁₆	1 ³ / ₁₆
KLD213-9NE	9 ¹ / ₄	1 ⁹ / ₃₂	1 ¹ / ₄

Journeyman™ Series

KLJ213-9NE	9 ¹ / ₄	1 ⁹ / ₃₂	1 ¹ / ₄
------------	-------------------------------	--------------------------------	-------------------------------

KLEIN TOOLS

High Leverage Side-Cutting Pliers

- High-leverage design. Rivet is closer to the cutting edge for 36% greater cutting and gripping power
- Streamlined design with sure-gripping, cross-hatched knurled jaws
- Induction-hardened cutting knives for long life
- Hot-riveted joint ensures smooth action and no handle wobble
- Nose Type: New England



Item #	Overall Length (in.)	Jaw Length (in.)	Jaw Thickness (in.)	Knife Length (in.)
KLD2000-9NE	9 ¹ / ₄	1 ⁹ / ₃₂	1 ⁵ / ₁₆	2 ⁵ / ₃₂

Journeyman™ Series

KLJ2000-9NE	9 ¹ / ₂	1 ¹ / ₄	5/ ₈	2 ⁵ / ₃₂
-------------	-------------------------------	-------------------------------	-----------------	--------------------------------

KLEIN TOOLS

High Leverage Side-Cutting Pliers

NE-Type

- Smooth, streamlined nose with knurled jaws
- Crimping die at the hinge for crimping sleeve connectors
- Plastic-dipped handles
- Knife Length: 25/32 in.



Item #	Overall Length (in.)	Jaw Length (in.)	Jaw Width (in.)	Jaw Thickness (in.)
KLD213-9NE-CR	9 ¹ / ₄	1 ⁹ / ₃₂	1 ¹ / ₁₆	5/ ₈



KLEIN TOOLS

High Leverage Diagonal Cutters

- Heavy-duty with head angled for easier work in confined areas
- Standard-bevel cutting knives
- Ultra-durable cutting knives for ACSR, bolts, nails and most hardened wire
- Plastic-dipped handles
- Overall Length: 8"



Item #	Cutting Knives
KLD248-8	Standard
KLD2000-48	Heavy-Duty

KLEIN TOOLS

Diagonal Cutter

- Standard-bevel cutting knives
- High-leverage design



Item #	Overall Length (in.)	Jaw Length (in.)	Jaw Width (in.)
KLD228-8	8	1 ³ / ₁₆	1 ³ / ₁₆
KLJ228-8	8	1 ³ / ₁₆	1 ³ / ₁₆
KLD2000-28	8	1 ³ / ₁₆	1 ³ / ₁₆

Journeyman™

KLJ2000-28	8 ¹ / ₂	1 ³ / ₁₆	1 ³ / ₁₆
------------	-------------------------------	--------------------------------	--------------------------------

KLEIN TOOLS

Diagonal Cutters

Heavy-Duty

- Heavier design for all-purpose use
- Tapered nose and standard-bevel cutting knives
- Plastic-dipped handles
- Overall length: 6"



Item #	Jaw thickness (in.)	Jaw width (in.)	Jaw length (in.)
KLD252-6	7/16	3/4	13/16

KLEIN TOOLS

Diagonal Cutters

Midget Pointed-Nose

- Narrow jaw and narrow hinge cutter
- Reaches into confined areas to permit full-flush cutting
- Fully polished head and neck
- With coil spring
- Plastic-dipped handles
- Overall length: 5"



Item #	Jaw thickness (in.)	Jaw width (in.)	Jaw length (in.)
KLD244-5C	5/16	1/2	11/16

KLEIN TOOLS

Side-Cutting Pliers



NE-Type

- Sure-gripping, cross-hatched knurled jaws
- New England nose
- Plastic dipped handles

Item #	Overall Length (in.)	Jaw Length (in.)	Jaw Width (in.)	Jaw Thickness (in.)	Knife Length (in.)
KLD201-6NE	6 ¹ / ₄	1 ³ / ₃₂	2 ⁹ / ₃₂	1/2	9/16
KLD201-7NE	7 ⁵ / ₁₆	1 ⁹ / ₃₂	1 ⁵ / ₃₂	1/2	5/8
KLD201-8NE	8 ¹ / ₂	1 ⁷ / ₁₆	1 ⁷ / ₃₂	5/8	2 ³ / ₃₂
KLD201-9NE	9 ¹ / ₄	1 ¹⁹ / ₃₂	1 ⁵ / ₁₆	5/8	2 ⁵ / ₃₂

KLEIN TOOLS

High Leverage Cable Cutter



- High-leverage design gives it amazing cutting capability
- Cable-gripping, shear-type jaws
- Makes clean, efficient cuts
- Ideal for working in confined spaces
- Plastic-dipped handles
- Length: 9-1/2"

Item #
KL63050

KLEIN TOOLS

Ratcheting Cable Cutters



- Unique ratchet-action holds cable tight and allows rapid, straight cuts with minimum effort
- Hold-open spring speeds cutting action
- Quick-release lever opens blade at any time during operation
- Large handles have limit guards and plastic covering
- Can be locked in closed position for pouch carrying
- Length: 10"

Item #
KL63060

KLEIN TOOLS

Wire Stripper-Cutter



- Strips six standard wire sizes without nicking wire
- Scissors action of 1/2" wide cutter makes clean cuts with little effort
- Serrated nose jaws to bend, shape, or pull wire: holes for looping wire ends
- Coil-spring opening action reduces fatigue
- Plastic-covered handles
- Overall length 6-1/8"

Item #
KL1011



KLEIN TOOLS
Wire Strippers & Cutters
Klein Kurve®

- Curved handles help reach into confined areas
- Handy closure lock for convenient storage
- Wire looping and bending holes
- Strong-gripping serrated nose for easy bending, shaping, and pulling of wire
- Coil spring provides fast self-opening action
- Double-dipped comfort grips
- Screw-shearing holes
- Cleanly shears 6-32 and 8-32 screws
- Blue/Yellow handle cover
- Strip solid AWG gauges: 10-18"
- Strips standard AWG gauges: 12-20"



Item #

KL11055

KLEIN TOOLS

Wire Stripper-Cutter

- Flat design makes them easy to store and carry
- Narrow nose fits into tight places
- Strip wire quickly, cleanly, evenly
- Strong, hardened-steel with precision-ground stripping holes
- Clear gauge markings on both sides
- Blank oxide finish
- Plastic-dipped handles
- Overall length: 6-1/4"



Item #	Handle	Strips/Cuts
KL11045	Yellow	10-18 AWG solid
KL11046	Red	16-26 AWG stranded
KL11047	Yellow	22-30 AWG solid

KLEIN TOOLS

Wire Stripper, Cutter and Crimper

- For use on insulated and non-insulated connectors
- Cuts and strips wire, sizes 10-22 AWG
- Cuts bolt sizes 4-40, 5-40, 6-32, 8-32, 10-32, and 10-24
- Plastic covered handles
- Overall length 8-1/4"



Item #

KL1010

KLEIN TOOLS

Cable Strippers/Cutters

- Strong-gripping serrated nose; for easy bending, shaping and pulling of wire
- Wire looping and bending holes
- Screw-shearing holes
- Coil spring provides fast self-opening action
- Handy closure lock for convenient storage
- Double-dipped comfort grips
- Overall Length: 7-3/4"



Item #	Strips and Cuts	Type NM-B Cable
KLK1210	10 & 12 AWG solid	10/2 & 12/2
KLK1412	12 & 14	12/2 & 14/2

KLEIN TOOLS

Terminal Crimping Tool

- Crimping die marked for insulated and non insulated solderless terminals and connectors
- Crimps insulated and non-insulated solderless terminals and connectors
- Both handles red plastic-dipped
- Designed for sizes 10-22 AWG
- Overall length 9-3/4"



Item #

KL1005

KLEIN TOOLS

Terminal Crimping Tool

- Designed for crimping non-insulated solderless terminals and connectors ranging from No. 10 to 22 AWG
- Specially hardened wire cutter in nose
- Tapered nose for working in confined spaces
- Plastic-dipped handles
- Overall length 9-3/4"



Item #

KL1006

KLEIN TOOLS

Wire Cutter/Terminal Crimper

- Two wire cutters - one at tip, the other halfway back near stripping holes
- Crimps insulated and non-insulated terminals, lugs and splices. Cuts wire, strips wire, cuts bolts, crimps 7-8 mm ignition terminals
- Strips No. 8 to 18 AWG solid wire or 10 to 22 AWG standard wire
- Cuts bolt sizes 6-32, 8-32, 10-32, 10-24 and 4-40
- Pivot nut adjusts tension, left-and right-hand wire-looping holes near tip
- Plastic-covered handles
- Overall length: 8-3/4"

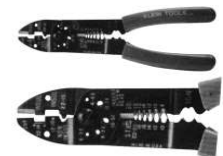

Item #

KL1001



KLEIN TOOLS

Square-Recess Tip Screwdrivers

- Color-coded handle ends for quick identification
- Round shank with Robertson tip for square-recess screws
- Chrome-plated shank
- Cushion grip handles



Item #	Point Size	Color Code	For Screw Sizes
KL662	No. 2	Red	8, 9, 10
KL663	No. 3	Black	12 and 14

KLEIN TOOLS

Cabinet Tip Screwdrivers

- Narrow cabinet tip permits blade access where space is limited
- Round chrome-plated shank
- Cushion grip handles



Item #	Shank Tip Width x Shank Length (in.)	Overall Length (in.)
KL601-3	3/16 x 3	6 3/4
KL601-4	3/16 x 4	7 3/4
KL601-6	3/16 x 6	9 3/4
KL601-8	3/16 x 8	11 3/4
KL601-10	3/16 x 10	13 3/4

Heavy-Duty Shanks

KL605-8	1/4 x 8	12 11/32
KL605-4	1/4 x 4	8 11/32
KL605-6	1/4 x 6	10 11/32

KLEIN TOOLS

Cushion-Grip Screwdriver Set

5-Piece

- A basic selection of the most frequently used screwdrivers
- Featuring heat-treated and tempered-steel blades
- Comfortable cushion-grip handles
- In reclosable vinyl pouch

Set Contains:

- 600-4: Heavy-duty square-shank, keystone-tip, overall length: 8-11/32"
- 601-6: Round-shank, cabinet-tip, overall length: 9-3/4"
- 602-6: Heavy-duty round-shank, keystone-tip, overall length: 10-15/16"
- 603-4: Round-shank, No. 2 Phillips-tip, overall length: 8-5/16"
- 605-6: Heavy-duty round-shank, cabinet-tip, overall length: 10-11/32"



Item #

KL85075

KLEIN TOOLS

Cushion-Grip Screwdriver Set

7-Piece

- Specialty set for wide variety of applications
- In reclosable vinyl pouch

Set Contains:

- 600-4: Heavy-duty square-shank, keystone-tip, overall length: 8-11/32"
- 601-6: Round-shank, cabinet-tip, overall length: 9-3/4"
- 602-6: Heavy-duty round-shank, keystone-tip, overall length: 10-15/16"
- 603-4: Round-shank, No. 2 Phillips-tip, overall length: 8-5/16"
- 605-6: Heavy-duty round-shank, cabinet-tip, overall length: 10-11/32"
- 670-6: Cabinet-tip rotary screwdriver, overall length: 9-3/4"
- K36: Slotted screw-holding screwdriver, overall length: 9-3/4"



Item #

KL85077

KLEIN TOOLS

Cushion Grip Screwdriver Set

7-Piece

- Convenient selection of popular screwdrivers
- In reclosable vinyl pouch

Set Contains:

- Square-shank, keystone-tip* 8-11/32" overall length
- Round-shank, keystone-tip* 10-15/16" overall length
- Round-shank, cabinet-tip 6-3/4" overall length
- Round-shank, cabinet-tip 9-3/4" overall length
- Round-shank, cabinet-tip* 8-11/32" overall length
- Round-shank, No. 1 Phillips-tip 6-3/4" overall length
- Round-shank, No. 2 Phillips-tip 8-5/8" overall length



Item #

KL85076

KLEIN TOOLS

5-Piece Screwdriver Set

Journeyman™

- Includes one cabinet-tip, two Phillips-tip, and two keystone-tip screwdrivers
- Advanced blade technology for the strongest blade
- Exclusive Journeyman™ design for maximum turning power
- Ultra-comfort tri-lobe handle for exceptional control, grip and balance
- Patented Tip-Ident™ quickly identifies screwdriver tip/orientation
- Bolster reinforces shaft for hard use



Item #

KLJSDS01



KLEIN TOOLS
7-Piece Screwdriver Set
Journeyman™

- Includes two cabinet-tip, three Phillips-tip, and two keystone-tip screwdrivers
- Advanced blade technology for the strongest blade
- Exclusive Journeyman™ design for maximum turning power
- Ultra-comfort tri-lobe handle for exceptional control, grip and balance
- Patented Tip-Ident™ quickly identifies screwdriver tip/orientation
- Bolster reinforces shaft for hard use



Item #
KLJSDS02

KLEIN TOOLS

Keystone Tip Screwdriver

- Designed for the most demanding uses
- With heavy-duty shank for wrench-assisted turning
- Cushion grips



Item #	Shank Tip WidthxLength (in.)	Shank Lgth. (in.)
--------	------------------------------	-------------------

Square Shank

KL600-4	¼x4	8 ¹¹ / ₃₂
KL600-6	⅝x6	10 ¹⁵ / ₁₆
KL600-8	¾x8	13 ⁷ / ₁₆
KL600-12	½x12	17 ⁷ / ₁₆

Round Shank

KL600-1	¼x1½	3 ⁷ / ₁₆
KL602-3	7[32]x3	6¾
KL602-4	¼x4	8 ¹¹ / ₃₂
KL602-6	⅝x6	10 ¹⁵ / ₁₆
KL602-8	¾x8	13 ⁷ / ₁₆

KLEIN TOOLS

Nut Driver Set

Cushion Grip Hollow Shank

- Cushion-grip handle allows for greater torque and comfort
- Handle-ends color-coded according to hex size
- Shank length 3" for all drivers
- Set includes sizes: 3/16", 1/4", 5/16", 11/32", 3/8", 7/16", 1/2"



Item #
KL631

KLEIN TOOLS

Phillips-Tip Screwdrivers

Round-Shanks

- Cushion-Grip handle allows for greater torque and comfort
- Patented Tip-Ident® quickly identifies the type of screwdriver and screwdriver tip orientation
- Premium chrome plated for smooth feel and corrosion resistance
- Internal Flanges inside handle provide solid, twist-resistant blade anchor
- Special heat-treated shafts; precision-machined tip for exact fit
- Provides accurate fit and torque without slippage



Item #	Point Size	Shank Length (in.)	Overall Length (in.)
KL603-1	No. 2	1½	3 ⁷ / ₁₆
KL603-3	No. 1	3	6¾
KL603-4	No. 2	4	8 ⁵ / ₁₆
KL603-6	No. 3	6	11
KL603-7	No.2	7	11 ⁵ / ₁₆
KL603-10	No. 2	10	14 ⁵ / ₁₆

KLEIN TOOLS

Screwdrivers/Nut Drivers

- Cushion-grip handle for greater torque and added comfort
- End of handle is marked to quickly identify tool
- Overall Length: 7-3/8"



Sizes:

- 32476: 5/16" nut driver, #2 Phillips, 9/32" slotted, #1 Phillips, 3/16" slotted
- 32477: 5/16" nut driver, 1/4" nut driver, #2 Phillips, 1/4" slotted, #1 Phillips, 3/16" slotted, #15 Torx®, #10 Torx®, #1 square, #2 square
- 32500: 3/8", 5/16", 1/4" nut drivers, #1 and #2 Phillips, 1/4" and 3/16" slotted, #10 and #15 Torx®, #1 and #2 square recess

Item #	Type
KL32476	5-in-1
KL32477	10-in-1
KL32500	11-in-1

KLEIN TOOLS

Magnetic Screwdriver

w/ 32-Piece Tamperproof Bit Set

- Cushion-grip handle for greater torque and comfort
- Sturdy bit and screw holding magnet
- Includes complete tamperproof bit set in block
- Torx® bits included: T7, T8, T10, T15, T20, T25, T27, T30 and T40
- Fraction Hex bits included: 3/32", 7/64", 1/8", 9/64", 5/32", and 3/16"
- Metric Hex bits included: 2 mm, 2.5 mm, 3 mm, 4 mm, and 5 mm
- Spanner bits included: 4, 6, 8, and 10
- Tri-Wing® bits included: 1, 2, 3 and 4
- Torq-Set® bits included: 6, 8 and 10
- Includes 1/4" square to 1/4" hex adaptor to drive sockets



Item #
KL32510



KLEIN TOOLS
Cushion-Grip Nut Drivers

Hollow-Shaft

- Full hollow shafts facilitate work
- Internal flanges provide solid, twist-resistant shaft anchor
- Premium chrome plated for smooth feel and corrosion resistance
- Cushion-Grip handle allows for greater torque and comfort
- Fits over long bolts and studs



Item #	Color Code	Hex Size (in.)
KL630-3/16	Black	3/16
KL630-1/4	Red	1/4
KL630-5/16	Yellow	5/16
KL630-11/32	Green	11/32
KL630-3/8	Blue	3/8
KL630-7/16	Brown	7/16
KL630-1/2	Red	1/2
KL630-9/16	Orange	9/16
KL630-5/8	Yellow	5/8

KLEIN TOOLS

Erection Wrenches



- Forged from select alloy steel to withstand high-leverage and heavy loads
- Extra-heavy-duty head area gives maximum strength and durability
- Continuous taper of handle makes lining-up bolt holes easy and works on a range of bolt and/or hole sizes without binding
- Extra-large hub area works on larger diameter holes than other wrenches
- Catalog number, bolt size and nominal opening size are stamped on every wrench for easy identification
- American Bridge design

Item #	Bolt Size (in.)	Nominal Opening (in.)	Length (in.)
KL3210	1/2	7/8	14 1/2
KL3211	5/8	1 1/16	14 3/4
KL3212	3/4	1 1/4	16 1/2
KL3213	7/8	1 7/16	17 1/4
KL3214	1	1 5/8	17 11/16
KL3219	1/2	3/4	14 5/8
KL3220	1/2	13/16	14 1/2
KL3221	5/8	1	14 3/4
KL3222	3/4	1 1/8	16 1/2
KL3223	7/8	1 5/16	17 1/4
KL3224	1	1 1/2	17 11/16

KLEIN TOOLS

**Ratcheting
Construction Wrench**



1/2" Drive

- Accepts 1/2" square-drive hex socket
- Reversible ratchet
- Eliminates the need for carrying several fixed-size wrenches
- Forged from select alloy steel with continuous-taper handle for aligning bolt holes
- Industrial black finish for corrosion resistance
- Overall Length: 15"

Item #

KL3238

KLEIN TOOLS

Construction Wrench



Adjustable-Head

- Versatile wrench fits all nuts and bolts to 1-1/2"
- Eliminates the need for carrying several fixed-size wrenches
- Drop-forged from select alloy steel with continuous-taper handle
- Industrial black finish
- Max. Size Capacity: 1-1/2"
- Length: 16"

Item #

KL3239

KLEIN TOOLS

Adjustable Wrenches



Standard-Jaw

- Drop-forged from the finest steel alloy, hardened, and thoroughly tempered for great strength
- Wrench openings are smooth and accurately broached for close, correct fit to prevent slipping
- Handles are rounded and shaped for comfortable use
- Chrome finish

Item #	Length (in.)	Capacity (in.)
KL506-15	15 7/8	1 11/16
KL500-18	18 1/4	2 1/16
KL500-24	24	2 1/2

KLEIN TOOLS

Leather-Bottom Bucket

- Made of No. 1 canvas
- Leather reinforced bottom, extending 3" up the side
- 8"x8" inside pocket
- Rope handle
- 12" top and bottom dia., 17" height



Item #

KL5104



KLEIN TOOLS

Straight-Wall Bucket

- Made of heavy duty No. 6 canvas
- Black molded polypropylene bottom
- Rope handle
- 9" diameter, 14" height

Item #

KL5106



KLEIN TOOLS

Straight-Wall Bucket

Wide-Opening

- Made of heavy-duty No. 6 canvas
- Black molded polypropylene bottom
- Rope handle
- One 8"x8" inside pocket
- 12" diameter, 15" height

Item #

KL5109

With Swivel Snap

KL5109PS



KLEIN TOOLS

Oval Bucket

Aerial-Basket

- Made of heavy No. 6 canvas
- Black molded polypropylene bottom
- Two nylon polymer hooks
- 15 inside pockets
- 14" length, 7" width, 10" height

Item #

KL5144



KLEIN TOOLS

Tapered-Wall Bucket

- Made of tough No. 4 canvas
- Black molded polypropylene bottom
- Rope handle
- Riveted leather glove strap
- Equipped with swivel snap hook
- 15 inside pockets
- 12" top, 9" bottom, 12" height

Item #

KL5172PS



KLEIN TOOLS

Bull Pin Holder

- Leather construction; riveted to assure long life
- Holders for Klein bull pins
- Holds all standard bull pins
- Tunnel belt connection
- Belt Width: up to 3-1/2"
- Overall size: 3-1/4" x 12-1/4"

Item #

KL5417T



KLEIN TOOLS

Electrode Bag

- Bag is tough No. 4 canvas with heat-resistant hard-leather bottom
- Web loop for sliding over belt
- 2-1/2" diameter, front depth 12"

Item #

KL5471



KLEIN TOOLS

Bull-Pin and Bolt Bags

- No. 4 canvas with double bottom
- Bolt bag with bull-pin loop on each side
- Belt capacity: up to 3" wide
- Depth: 10"; Length: 5"; Width: 9"

Item # Desc.

KL5416 Loops for belt

KL5416T Tunnel for belt



KLEIN TOOLS

Tool Holder

- Leather construction; no exposed rivets on back
- Pockets for 7", 8" and 9" pliers, screwdrivers, folding rules and O.E. wrenches
- Nickel plated alloy snap
- Slotted to fit 2" wide belt
- 6-1/2"x11"

Item #

KL5118C



KLEIN TOOLS

Erection Wrench Holder

- Leather construction; tunnel loop is riveted to assure long life
- Has tool slots for two erection wrenches
- Holds erection wrenches and adjustable head construction wrench
- Belt width: up to 3-1/2" or to slide over D-rings, buckles, and other accessories
- Overall size: 6" x 9-1/2"

Item #

KL5459T





KLEIN TOOLS

Electrician Scissors

- Stainless steel blades to maintain blade durability and sharpness
- Blade is fully serrated for non-slip cutting action
- Free-fall snip feature for ease of use
- Cuts electrical communication 19-AWG and 23 AWG wire
- Extended handle provides comfort and cutting leverage for wire cutting application
- 56 HRC
- Overall Length: 6-5/16"
- Cutting Length: 1-7/8"



Item #

KL2100-8

KLEIN TOOLS

Electrician Snips

- Stainless steel blades to maintain blade durability and sharpness
- Blade is fully serrated for non-slip cutting action
- Cuts electrical communication 19-AWG and 23 AWG wire
- 56 HRC
- Overall Length: 5-1/4"
- Cutting Length: 1-7/8"



Item #

KL2100-9

KLEIN TOOLS

Cable Splicers Kit

- Cable-splicer's knife No. 44200
- Electrician's scissors with stripping notches
- Slotted leather holder for belts up to 2" wide
- Nominal Size: 2-1/8" x 7-1/2"



Item #

KL46037

KLEIN TOOLS

Tie-Wire Reel

- Rugged, lightweight reel feeds pre-coiled wire smoothly, easily, and quickly
- Designed for left or right hand use
- 6-1/4" dia. x 2-15/16" W
- Has large, comfortable rewind knob
- Easily removed cover plate that permits quick, convenient reloading



Item #

KL27400

KLEIN TOOLS

Tie-Wire Reel Pad

- Worn on the belt under tie-wire reel
- Made of 3/16" thick rigging leather
- With slots to accommodate belts up to 2" wide
- Pad size is 7"x7" with rounded corners
- Underside has a sponge-rubber pad to minimize hip fatigue



Item #

KL27450

KLEIN TOOLS

Conduit Reamers

Thin-Wall

- Locks onto screwdriver, reams and smooths 1/2", 3/4" and 1" thin-wall conduit-ends
- Reams inside/outside at the same time
- Fits up to 3/8" keystone-tip screwdrivers



Item #

KL19352

KLEIN TOOLS

Scratch Awl

- Scribes metal, starts screw holes, performs a variety of piercing and punching jobs
- Rigid, chrome-plated, heat-treated, tempered-steel shank has full reinforcing bolster at handle for extra strength
- Flanged shank is anchored deep in full-sized amber plastic handle
- Cushioned Grip



Item #	Overall length (in.)	Blade length (in.)
KL650	7	3-1/2

KLEIN TOOLS

Tapping Tool

Six-in-One

- Quickly forms new threads, re-forms burred threads, and cleans out plaster obstructions
- Each tap size rethreads to next larger size if threads are stripped
- Two high-carbon steel taps are secured in reversible holder
- Six clearly marked thread sizes: 6-32, 8-32 and 10-32, 10-24, 12-24 and 1/4-20"



Item #	Overall Length (in.)
KL627-20	7-1/2

KLEIN TOOLS

Replacement Tap

- For No. 627-20 six-in-one tool



Item #	Tap Sizes
KL628-20	1/4-20, 12-24, 10-24



KLEIN TOOLS

Grizzly® Bar



- A heavy, strong, multi-purpose tool that saves time and effort on the job
- The 3" width protects concrete when stripping forms
- Efficient blade angle and 55-1/2" total length provide high leverage as a crow bar and nail and spike puller
- Blade is forged and hardened alloy with keyhole nail-pulling slot in center and V-notch in tapered edge

Item #

KL64306

KLEIN TOOLS

Broad-Head Bull Pins



- Forged, heat-treated bull pin increases efficiency by providing a larger striking surface; black finish
- Design of the head also reduces chance of pin slipping from the hand when aligning holes
- Angled head and smooth blending of radii increase strength and reduce the danger of chipping
- Below the head, squared-off shoulders have been forged to provide a surface for applying wrench to loosen wedged bull pins

Item #	Top Diameter (in.)	Point Diameter (in.)	Length (in.)
--------	--------------------	----------------------	--------------

KL3255	1/4	5/16	13
KL3256	1/16	1/4	10

KLEIN TOOLS

Connecting Bars

Round



- Provides extra leverage when positioning steel members and aligning bolt holes
- Forged fit-up bar is pointed on one end
- Chisel-end is at a 15° angle to give even greater leverage

Item #	Dia. (in.)	Length (in.)
--------	------------	--------------

KL3245	3/4	30
KL3247	3/4	24
KL3248	7/8	30

Straight Chisel End

KL3241	3/4	30
--------	-----	----

KLEIN TOOLS

Connecting Bars

Hex



- Provides extra leverage when positioning steel members and aligning bolt holes
- Forged fit-up bar is pointed on one end

Item #	Hex Dia. (in)	Length (in)
--------	---------------	-------------

Chisel-End at 15° angle

KL3242	3/4	30
KL3244	3/4	24

Straight Chisel-End

KL3240	3/4	30
--------	-----	----

KLEIN TOOLS

Rebar Hickey

- Exceptionally durable steel-alloy head
- Extra-strong handle to withstand punishing service conditions
- Hickey size: 4
- Bends Rebar Size: Nos. 7 (.875" dia.), 8 (1" dia.), 9 (1.128" dia.)
- Head Type/Bend Angle: Single/65°
- Handle Length: 60"



Item #

KL64312

KLEIN TOOLS

Barrel-Type Drift Pins



- Machined from quality alloy steel
- Tapers are uniform and blend into body diameter
- Tough, forged steel will properly end-peen in use
- Heat-treated for strength
- Black finish for rust resistance

Item #	Max Diameter (in.)	Point Diameter (in.)	Overall Length (in.)
--------	--------------------	----------------------	----------------------

KL3260	1 1/16	5/16	7 1/2
KL3261	1 3/16	7/16	8
KL3262	1 5/16	1/2	8



LOUISVILLE LADDER CORP.

Fiberglass Step Ladders

**Type IA 300 Lb. Rated
FS1500 Series**

- ProTop™ is versatile and durable
- Heavy duty bottom back brace provides additional strength to the bottom of the ladder
- Slip Resistant Rubber Feet



Item #	Size (ft.)	Bottom Wdth. (in.)	Approx. Spread (in.)	Approx. Wt. (lbs.)
LOFS1502	2	17	18¼	8
LOFS1503	3	18⅞	23	12
LOFS1504	4	18⅞	28	14
LOFS1505	5	20⅜	34	17
LOFS1506	6	21⅞	40	20
LOFS1508	7	25⅞	52¼	26
LOFS1510	10	27⅞	65	34
LOFS1512	12	30⅞	78	47

LOUISVILLE LADDER CORP.

Fiberglass Step Ladders

**Type IAA 375 Lb. Rated
Brute™**

- ProTop™ is versatile and durable
- Insider spreader braces
- Wide back braces



Item #	Size (ft.)	Bottom Width (in.)	Approx. Spread (in.)	Approx. Wt. (lbs.)
LOFS1404HD	4	18⅞	28	15
LOFS1406HD	6	21⅞	40	21
LOFS1408HD	8	24⅞	52	28
LOFS1410HD	10	27⅞	65	34
LOFS1412HD	12	30⅞	78	51

LOUISVILLE LADDER CORP.

Fiberglass Twin Front Ladders

**Type IAA 375 Lb. Rated
FM1400 Series**

- Da Boot provides strength and durability
- Thick non-marring provides a slip resistant footing
- Heavy double gusset bracing
- Each side is designed to support one person including materials up to 375 lbs.
- Total combined weight on ladder must not exceed 750 lbs. (375 lbs. per side)



Item #	Size (ft.)	Bottom Width (in.)	Approx. Spread (in.)	Approx. Wt. (lbs.)
LOFM1414HD	14	34¾	113	84
LOFM1416HD	16	37¾	128	100

LOUISVILLE LADDER CORP.

Fiberglass Twin Front Ladders

**Type IAA 300 Lb. Rated
FM1500 Series**

- Each side is designed to support one person including materials up to 300 lbs.
- Total combined weight on ladder must not exceed 600 lbs. (300 lbs. per side)



Item #	Size (ft.)	Bottom Width (in.)	Approx. Spread (in.)	Approx. Wt. (lbs.)
LOFM1504	4	19⅞	37½	19
LOFM1505	5	21⅞	44⅞	22
LOFM1506	6	22⅞	52⅞	27
LOFM1507	7	24⅞	59⅞	30
LOFM1508	8	25⅞	67⅞	34
LOFM1510	10	28⅞	81⅞	44
LOFM1512	12	31⅞	96¾	62

LOUISVILLE LADDER CORP.

Fiberglass Extension Ladders

**Type IA, 300 Lb. Rated
FE 7200 Series**

- Tempered, serrated aluminum D-rungs provide for a slip-resistant surface



Item #	Total Length (ft.)	Length Ea. Section (ft.)	Max Ext. Length (ft.)	Approx. Wt. (lbs.)
LOFE7236	36	18	32	110
LOFE7240	40	20	35	117



LOUISVILLE LADDER CORP.

Tripod Ladders

Type IA 300 Lb. Rated
FT1000 Series



- Full metal boot, aluminum angle feet with thick slip resistant rubber tread

Item #	Size (ft.)	Bottom Width (in.)	Approx. Spread (in.)	Approx. Wt. (lbs.)
LOFT1004	4	32½	35	17
LOFT1005	5	34	35	20
LOFT1006	6	35½	41	24
LOFT1007	7	40¼	48	27
LOFT1008	8	42¾	54	31
LOFT1010	10	52¼	66	44
LOFT1012	12	55¼	78	53

LOUISVILLE LADDER CORP.

Fiberglass Extension Ladders

Type IA 300 Lb. Rated
FE3200 Series



- Flat top, D-shape provides greater standing area than round rungs; fully serrated for slip-resistant surface

Item #	Total Lgth. (ft.)	Lgth. Ea. Section (ft.)	Max. Extended Lgth. (ft.)	Approx. Wt. (lbs.)
LOFE3216	16	8	13	35
LOFE3220	20	10	17	43
LOFE3224	24	12	21	50
LOFE3228	28	14	25	57
LOFE3232	32	16	29	68

LOUISVILLE LADDER CORP.

Aluminum Extension Ladders

Type IA 300 Lb. Rated
AE2000 Series



- Tempered aluminum D-rungs are hydraulically double crimped to side rails and fully serrated for a slip-resistant surface

Item #	Total Lgth. (ft.)	Lgth. Ea. Section (ft.)	Max. Extended Lgth. (ft.)	Approx. Wt. (lbs.)
LOAE2216	16	8	13	30
LOAE2220	20	10	17	37
LOAE2224	24	12	21	42
LOAE2228	28	14	25	55
LOAE2232	32	16	29	62
LOAE2240	40	20	35	82

LOUISVILLE LADDER CORP.

Telescoping Planks

Ladder Pro™



- Manufactured with heavy wall aluminum tubing to prevent the twisting and flexing
- Built-in, skid-resistant surface reduces slips
- Stores and transports in approximately half of its fully-extended length

Item #	Plank (ft.)	Stand. Extension (ft.)	Width (in.)	Approx. Wt. (lbs.)
LOLP-2921-13A	13	8-13	12	39
LOLP-2921-16A	16	10-16	12	49

LOUISVILLE LADDER CORP.

Ladder Stabilizers

Ladder Pro™

- Fits extension and single ladders with rail up to 4"x1-3/4"
- Holds ladder 12" from wall and spans 48" to clear most windows
- Attach with 2 U-bolts and feature replaceable extra heavy duty rubber tips



Item #
LOLP-2200-00



LOUISVILLE LADDER CORP.
Adjustable Stabilizer
Ladder Pro™

- Fits extension and single ladders with rail up to 4"x1-3/4"
- Aluminum bracket with vertical adjustments hold ladder from 13" to 25" from wall and spans 48" to clear most windows
- Attach with 2 U-bolts and feature replaceable extra heavy duty rubber tips



Item #
LOLP-2210-00

LOUISVILLE LADDER CORP.
Pro-Guards
Ladder Pro™

- Fits most fiberglass and aluminum extension and single ladders



Item #
LOLP-5510-00

LOUISVILLE LADDER CORP.
Ladder Leveler

- Features plated steel construction and a safety guard to protect from accidental release
- Maximum differential of 15"
- Ideal for using on extension or straight ladders on uneven surfaces



Item #
LOLP-2300-00

LOUISVILLE LADDER CORP.
Runglock Replacement Kit

QuickLatch

- Runglock replacement kit

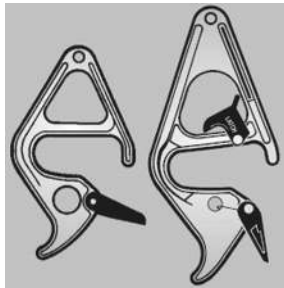

Item #	Fits Series
LOPK100A	All FE1600
LOPK100C	All FE3200
LOPK100D	All AE3200

LOUISVILLE LADDER CORP.
Swivel Safety Shoe Kit

- Replacement for aluminum or fiberglass ladders

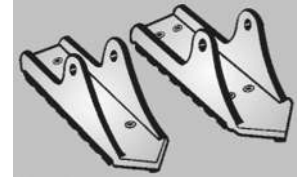

Item #	Fits Series
LOPK110D	All AE3200, All FE3200



GUARDIAN FALL PROTECTION
Basemate Ladder Stabilizer

- Cuts the risk of falls by allowing ladders to remain stable on uneven ground
- Easily attaches to the bottom of any standard ladder
- Wide base gives added support/stability to extension ladders
- Exceeds Grade 1 and to Type 1A ladder requirements by 20%
- Weight tested to 1,200 lbs.
- Made of hardened steel
- Patented triple action locking system with one foot operation (patented design)
- Installation to most fiberglass, aluminum and wood extension ladders (12" to 20" rung width)
- Adds less than 12 lbs. to the base of the ladder



Item # Part #
GU02475 02475



STINSON
Aluminum Ladder Jacks

- Fully assembled
- Rated 250# per ladder jack
- No busted knuckles nor pinched fingers
- Fits inside and outside face of ladder
- Will accommodate up to 18" plank
- To be used with Type I or IA ladders



Item #	Desc.
MPJACKSFL	Short Body, 4½ lbs., Spans 2 rungs
MPJACKXFL	Long Body, 5½ lbs., Spans 3 rungs

STINSON

STINSON
Multi-Purpose Ladders™
Little Giant®



- Heavy-wall aircraft-grade aluminum construction
- Rated to hold up to 300 lbs.
- Combines 24 different ladders into one convenient ladder system

Item #	Weight capacity	Min. extension	Max. extension	Min A-frame height	Max. A-frame height	Storage height
LI10102BP	300-lbs.	9'	15'	4'	7'	4'7"
LI10103BP	300-lbs.	11'	19'	5'	9'	5'7"
LI10126BP	300-lbs.	13'	23'	6'	11'	6'7"

STINSON
Multi-Purpose Leg Leveler
Little Giant®

- Safe, stable solution for uneven surfaces
- Not for use on fiberglass ladders



Item #
LI10106

STINSON
Ladder Wall Standoff
Little Giant®

- Adds more versatility to any Little Giant® ladder
- 4' span fixed position
- Attaches easily



Item #
LI10111

STINSON
Scaffold Planks
Master Plank



- Lightweight - up to 40% less than like-rated all-aluminum planks
- Stiffer than straight channeled all-aluminum planks
- Comfort of wood working surfaces, especially in temperature extremes
- Industry rated at 500 lbs. (2-man)

Item #	Width	Length	Weight (lbs.)
MPP1614	14"	15'9"	47
MPP2014	14"	19'6"	61
MPP2414	14"	23'6"	74
MPP2814	14"	27'3"	108
MPP3214	14"	31'3"	139



WARNER TOOL
Step-Up Bench
EZ-Stride®

- Made of lightweight, extruded, high-strength aluminum
- Set up quickly and easily
- Fit in tight spaces and are easy to transport
- Holds up to 300 lbs. with tools



Item #
WAR10227



WERNER CO.
Folding Access Ladders

Aluminum

- Capacity 300 lbs. (combined weight of user materials)
- Wood push/pull rod allows easy open and close
- Counter-balance mechanism eliminates sag and springiness
- Heavy-duty hinges ensure rigid structure
- Adjustable feet for easy installation and correct fit



Dimensions:

- Floor to Floor Height Range From - To (ft. & in.): 7 & 4 - 8 & 9
- Floor to Ceiling Height Range From - To (ft. & in.): 7 - 8 & 5
- Approx. Ladder Width (in.): 14-1/4
- Approx. Cu. Ft. per Unit: 8.1
- Approx. Shipping Wt. (lbs.): 47.0

Item #	Rails (in.)	Flange (in.)	Steps (in.)	R.O. Width-Length (in.)
WEA2208	3-1/2	1	3-11/16	22-1/2 x 54



WERNER CO.

Square Modular Guard Rail System

The following steps show how to size a single-side, three-sided, and four-sided guard rail system:

- Determine the stage length and width
- Determine whether guardrail system is one-, two-, three-, or four-sided
- Read across the row to determine component requirements
- If ordering a three- or four-sided system, order two ERT-N for 12" and 14" stages, and two ERT-W for all stages 20" wide or greater
- If ordering a two sided system, double the single sided component requirement

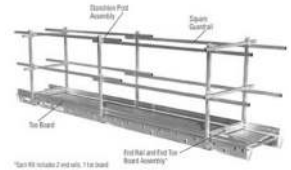

Item #	Desc.	Wt. Lbs.
WEERT-N	End rail and End toe board assembly-narrow	4.5
WEERT-W	End rail and End toe board assembly-wide	7
WESSP-47	Stanchion post assembly	5
WESGR-09	1½" square guardrail cut length-108"	6
WESGR-13	1½" square guardrail cut length-156"	8.5
WESTB-09	3½" toe board cut length-108"	4.5
WESTB-13	3½" toe board cut length-156"	6.5

Stage Length	Single-sided					Three-sided						Four-sided					
	SSP-47	SGR-09	SGR-13	STB-09	STB-13	SSP-47	SGR-09	SGR-13	STB-09	STB-13	ERT-N/ERT-W	SSP-47	SGR-09	SGR-13	STB-09	STB-13	ERT-N/ERT-W
8'	2	2	0	1	0	4	2	0	1	0	2	4	4	0	2	0	2
12'	3	0	2	0	1	5	0	2	0	1	2	6	0	4	0	2	2
16'	3	4	0	2	0	5	4	0	2	0	2	6	8	0	4	0	2
20'	4	2	2	1	1	6	2	2	1	1	2	8	4	4	2	2	2
24'	5	4	2	2	1	7	4	2	2	1	2	10	8	4	4	2	2
28'	6	2	4	1	2	8	2	4	1	2	2	12	4	8	2	4	2
32'	6	2	4	1	2	8	2	4	1	2	2	12	4	8	2	4	2
36'	6	10	0	5	0	8	10	0	5	0	2	12	20	0	10	0	2
39'	7	4	4	2	2	9	4	4	2	2	2	14	8	8	4	4	2

**Call an Edge sales
representative for help with
guard rail.**



WERNER CO.
Stage Platforms

**Aluminum
Task-Master®**



- Individual slip-resistant decking minimizes paint or material build-up
- Vinyl-coated end caps serve as hand grips and protect from sharp edges and surface marks
- Double end rung provides extra rigidity on stages 20' or longer - standard on stages with 5" or 6" rails
- Twist-Proof® Stage Design
- Ideal for ladder jack applications, swing stages, or catwalks

Item #	Width (in.)	Side Rail Length (ft.)	Side Rail Depth (in.)	Side Rail Flange (in.)	Approx. Shipping Wt. (lbs.)
Decorator Planks 1 Person-250 lbs. Rated					
WE2008	12	8	4	1 $\frac{3}{8}$	25
WE2012	12	4	1 $\frac{3}{8}$	36	
WE2016	12	16	4	1 $\frac{3}{8}$	48
WE2020	12	20	5	1 $\frac{3}{8}$	65
WE2024	12	24	5	1 $\frac{3}{8}$	78
Scaffold Planks 2 Person-500 lbs. Rated					
WE2316	12	16	4	1 $\frac{3}{8}$	48
WE2320	12	20	6	1 $\frac{3}{8}$	79
WE2324	12	24	6 Heavy-Duty	1 $\frac{3}{8}$	112
WE2328	12	28	6 Heavy-Duty	1 $\frac{3}{8}$	131
WE2330	12	30	6 Heavy-Duty	1 $\frac{3}{8}$	140
WE2332	12	32	6 Heavy-Duty	1 $\frac{3}{8}$	149
WE2408	14	8	4	1 $\frac{3}{8}$	27
WE2412	14	12	4	1 $\frac{3}{8}$	40
WE2416	14	16	5	1 $\frac{3}{8}$	58
WE2420	14	20	6	1 $\frac{3}{8}$	85
WE2424	14	24	6	2	109
WE2428	14	28	6	2	127
WE2432	14	32	6 Heavy-Duty	2	182
Stage Platforms 2 Person-500 lbs. Rated					
WE2508	20	8	4	1 $\frac{3}{8}$	33
WE2512	20	12	4	1 $\frac{3}{8}$	48
WE2516	20	16	5	1 $\frac{3}{8}$	70
WE2520	20	6	1 $\frac{3}{8}$	102	
WE2524	20	24	6	1 $\frac{3}{8}$	121
WE2528	20	28	6	2	157
WE2532	20	32	6	2	179
WE2608	24	8	4	1 $\frac{3}{8}$	38
WE2612	24	12	4	1 $\frac{3}{8}$	56
WE2616	24	16	5	1 $\frac{3}{8}$	81
WE2620	24	20	6	1 $\frac{3}{8}$	115
WE2624	24	6	1 $\frac{3}{8}$	138	
WE2628	24	28	6	2	168
WE2632	24	32	6	2	191



Item #	Width (in.)	Side Rail Length (ft.)	Side Rail Depth (in.)	Side Rail Flange (in.)	Approx. Shipping Wt. (lbs.)
WE2708	28	8	4	1½	41
WE2712	28	12	4	1½	60
WE2716	28	16	5	1½	87
WE2720	28	20	6	1½	124
WE2724	28	24	6	1½	147
WE2728	28	6	2	187	
WE2732	28	32	6	2	213
Stage Platforms 3 Person-750 lbs. Rated					
WE3112	24	12	4	2	64
WE3116	24	16	5	2	92
WE3120	24	20	5	2	115
WE3124	24	6	2	145	
WE3128	24	28	6 Heavy-Duty	2	204
WE3132	24	32	6 Heavy-Duty	2	236
WE3136	24	36	6 Heavy-Duty	2	323
WE3139	24	39	6 Heavy-Duty	2	365
WE3208	28	8	4	2	48
WE3212	28	12	4	2	71
WE3216	28	16	5	2	103
WE3220	28	20	5	2	128
WE3224	28	24	6	2	161
WE3228	28	6 Heavy-Duty	2	220	
WE3232	28	32	6 Heavy-Duty	2	251
WE3236	28	36	6 Heavy-Duty	2	344
WE3239	28	39	6 Heavy-Duty	2	388

• Edge rents & repairs span planks.

• Call today to check out our large inventory.



SAFWAY SERVICES

Mobile Work Platform

Safway®

Safway's Mobile Work Platforms are one of the safest options for painters, plasterers, maintenance workers and various other trades that require a firm working platform

Secure:

- A swing-in gate on each side of the platform offers safe access, and guardrail panels always provide the correct guardrail location, regardless of the platform level
- Two guardrail panels (complete with toeboards) connect to provide proper guardrail protection on all four sides
- There are no loose nuts and bolts, and no special tools are required for construction

Durable:

- Rigid square steel construction
- Special side brace configuration that protects the plywood deck
- Platform side braces that attach to frames with heavy-duty spring-loaded lock pins that are secured when rotated
- 5" casters that are equipped with a wheel and swivel lock

User Friendly:

- Easily set up by one person
- glides through 30" wide doorways
- Independent adjustment of each ladder frame permits use on stairways
- Platform adjusts up or down in 4" increments
- Side braces allow movement over lower obstacles and eliminates the need for lower cross braces
- Workers can climb ladder frames at either end for easy platform access
- A disassembled unit can be stored in the space required for a step ladder

SWP includes:

- (2) 6' ladder frames
- (2) side braces
- (1) plywood platform
- (4) 5" casters
- (4) snap pins

Item #	Weight (lbs.)
SASWP	150



SAFWAY SERVICES

Guardrail Panel Assembly

Safway®

SWPGRA includes:

- (2) 6' guardrail panels
- (4) hinge pins

Item #	Weight (lbs.)
SASWPGRA	72



SAFWAY SERVICES

Platform Extension Assembly

Safway®

SWP3X includes:

- (2) 39" ladder frames
- (1) plywood platform
- (2) side braces
- (4) snap pins

SWP6X includes:

- (2) 6' ladder frames
- (1) plywood platform
- (2) side braces
- (4) snap pins

Item #	Weight (lbs.)
SASWP3X	104
SASWP6X	126



SAFWAY SERVICES

Narrow Outrigger Assembly

Safway®

SWPNORA includes:

- (4) narrow outriggers
- (4) 5" casters
- (4) snap pins

Item #	Weight (lbs.)
SASWPNORA	152



GUARDIAN FALL PROTECTION

Pump Jack Systems

Qual-Craft

- Accommodates (2) 2"x10" wood planks w/ toe boards attached
- Foot action does all the work
- Raise to position and lower with the hand crank
- Positive double-lock system brake secures itself to wood poles
- For use with fabricated wood poles constructed of spliced 2x4's up to 30' in height
- Special hand crank to maximize performance and durability



Item #
QC2200



GUARDIAN FALL PROTECTION
Pump Jack Systems

Brace
Qual-Craft



- Accommodates (2) 2"x10" wood planks w/ toe boards attached
- Foot action does all the work
- Raise to position and lower with the hand crank
- Positive double-lock system brake secures itself to wood poles
- For use with fabricated wood poles constructed of spliced 2x4's up to 30' in height
- Special hand crank to maximize performance and durability

Item #
QC2201

GUARDIAN FALL PROTECTION
Wall Jack

Qual-Craft



- Constructed of heavy-duty malleable iron castings
- Designed for use with one 2 x 4 pole
- Capacity: 1000 lbs. per jack
- For use with 1" OD steel pipe

Item #
QC2601

GUARDIAN FALL PROTECTION
Fixed Roof Brackets

Qual-Craft



- Commercial grade-11 gauge steel construction
- Unit has slots for easy installation & removal without damaging the shingles

Item #	Size	Desc.
QC2501	10" x 45°	Fits 2x10 plank
QC2504	10" x 45°	Fits 2x6 plank

GUARDIAN FALL PROTECTION
**Adjustable
Roof Brackets**
Qual-Craft



- For use on variable pitched roofs
- 10" adjustable platform
- 3-position platform: 30°, 45°, 60°
- For easy installation and removal without damaging the shingle
- Capacity: 1 worker plus 40 lbs. per 8' staging
- Maximum 8' spacing between brackets

Item #
QC2500



WERNER CO.
Pump Jack System

- Easy to assemble
- Compatible with most major aluminum systems

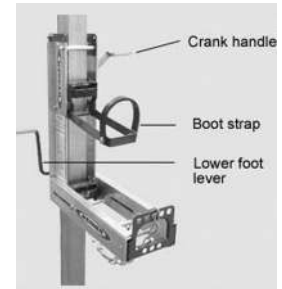

Item #	Desc.	Width (in.)	Length (in.)	Height (in.)
WEPJ-6P	6' Aluminum pole	3	74.5	3.4
WEPJ-12P	12' Aluminum pole	3	146.5	3.4
WEPJ-18P	18' Aluminum pole	3	217.5	3.4
WEPJ-24P	24' Aluminum pole	3	290.5	3.4
WEPJ-100	Pump Jack	24	28.75	9.5
WEPJ-ERN	End rail kit(narrow)	6	49	9
WEPJ-ERW	End rail kit(wide)	5	49	9
WEPJ-PC	Pole Connector	3.5	73	3
WEPJ-PF	Pole foot	8.5	3.5	
WEPJ-SBF	Foldable support brace	6.5	54	3
WEPJ-SBR	Rigid support brace	37	38	3
WEPJ-SN	Safety net	8	24	8
WEPJ-WB	Work bench	20.5	21	8.5



WERNER CO.
Nestable Stages

For Use With The Pump Jack System



- Continuous work platform reduces trip hazard; 2-person - 500 lb. rating

Item #	Desc.
WEWNS2412	14"x12' Stage
WEWNS2520	20"x20' Stage
WEWNS2416	14"x16' Stage
WEWNS2524	20"x24'
WEWNS2420	14"x20' Stage
WEWNS2612	24"x12' Stage
WEWNS2424	14"x24' Stage
WEWNS2616	24"x16' Stage
WEWNS2512	20"x12' Stage
WEWNS2620	24"x20' Stage
WEWNS2516	20"x16'
WEWNS 2624	24"x24' Stage



GENIE INDUSTRIES
Aerial Work Platforms
AWP™ Super Series™



- Auxiliary platform lowering
- Easily rolls through standard doorways
- AC power to platform
- Small outrigger footprints
- Easy loading in pickup trucks
- Rear access forklift pocket
- LED lights confirm proper set-up
- Also available in DC

Item #	Platform Height	Working Height	Capacity (lbs.)
GNAWP-25SAC	24' 10"	30' 10"	350
GNAWP-30SAC	29' 6"	35' 6"	350

GENIE INDUSTRIES
Contractor Lift

Superlift
SLC™



- Loads easily into a pickup truck for transporting
- Rear transport wheel assembly
- Two speed winch
- Stabilizer set (standard on SLC-18 and SLC-24)
- Height - Stowed: 86 in.
- Length - Stowed: 34 in.
- Width: 31-1/2 in.
- Load Height - Minimum: 6 in...
- Load Capacity - 14 in. (36cm)
- Load Center - 650 lbs.

Item #	Net Weight - Standard Base (lbs.)	Working Height Standard Forks Down	Working Height Standard Forks Up	Length - Operating (in.)
GNSLC-12	225	11' 2"	12' 11"	63
GNSLC-18	307	16' 9"	18' 6"	73
GNSLC-24	374	22' 3"	24'	81

Call for a demo or more information on these products.



GENIE INDUSTRIES

Scissor Lift

Electric Self-Propelled GS™

- The solid steel deck platform has a slip-resistant surface
- Heavy-duty guardrails fold down quickly without tools for increased accessibility
- Built-in lanyard attachment points are provided

Standard Features:

- 39 in. (1 m) roll-out platform extension
- Proportional controls for lift and drive functions
- AC wiring to platform
- Manual platform lowering valve
- Tilt sensor with an audible alarm
- Pothole guards
- Automatic 25 amp battery charger
- Non-marking tires
- Hour meter



Item #	Lift Capacity ANSI, CE (lbs.)	Raise/ Lower Speed (sec)	Working Height (ft.)	Platform Height (ft.)	Height - Stowed (Guardrails Folded) (in.)	Height - Stowed (Guardrails) (in.)	Height - Stowed (Platform) (in.)	Wt
GNGS-2646	1,000	30/24	32	26	68	89¾	46	4530

GENIE INDUSTRIES

Material Lift

Manually-Operated Superlift®

- Standard base
- Available in 5, 10, 15, 20 & 25 foot heights
- Field-proven durability and dependability
- Welded steel base for extra support
- Stabilizers standard on 20 & 25 foot models
- No loose parts
- Stored height is 78-1/2 in.
- Width of standard base is 31-1/2 in.
- Ground clearance is 2 in.
- Includes standard forks



Item #	Working Ht. Forks Down	Working Ht. Forks Up	Load Cap. at 18" (lbs.)	Wt
GNSLA-5	4'10"	6'7"	1000	215
GNSLA-10	9'9"	11'5½"	1000	260
GNSLA-15	14'7½"	16'4"	800	317



GENIE INDUSTRIES

Scissor Lift

Electric Self-propelled GS™



- The solid steel deck platform has a slip-resistant surface
- Telescopic end rail can be raised to accommodate large loads
- Built-in lanyard attachment points

Standard Features:

- 39 in. (1 m) roll-out platform extension
- Compact design
- Automatic 25 amp battery charger
- Pothole guards and non-marking tires
- AC wiring to platform with tilt level sensor and audible alarm
- Turning Radius Outside: 61"
- Power Source: 24V (4 6V 245AH Batteries)
- Drive Speed - Stowed: 0-2.5 mph; Drive Speed - Raised: 0-0.6 mph
- Extension Deck Lift Capacity: 250 lbs.
- Length - Stowed: 72"
- Width: 30"
- Wheelbase: 52"
- Ground Clearance: 2-5/8"
- Platform Length - Outside: 64-3/8"; Platform Width - Outside: 29 1/4"; Platform Length - Extended: 103-3/8"
- Guard Height - ANSI/CSA: 39"; Guard Height - CE: 43-3/8"
- Gradeability: 30%
- Pothole Protection: Standard

Item #	Lift Capacity (lbs.)	Working Height ft. (in.)	Platform Height ft. (in.)	Height - Stowed (Guardrails) ANSI, CSA (in.)	Height - Stowed (Guard-rails) CE (in.)	Height - Stowed (Platform) (in.)	Wt
GNGS-1530	600	21	15	76	80	36½	2658
GNGS-1930	500	25 (1)	19 (1)	78	82½	38½	2956

GENIE INDUSTRIES

Material Lift

Manually-Operated Superlift®

- Standard base
- Compact design allows you to lift and maneuver in congested work areas; great for general lifting and delivery of materials
- Available in 4 and 8 foot lift heights
- Low loading height
- Optional stair rollers for easy movement on stairways
- Standard forks dimensions: 22-1/2 in. length and 20-1/2 in. width to center of forks
- Also available in straddle base



Item #	Working Ht.		Load Cap. at 12" (lbs.)	Wt
	Forks Down	Forks Up		
GNGL-4	4'1½"	5'11"	500	113
GNGL-8	8'3"	10'½"	400	132



GENIE INDUSTRIES
Material Lift
Super Hoist™

- Powered by either CO2 or compressed air
- The Super Hoist sets up in seconds — no tools required
- The one-piece platform attaches to cylinder with a twist of the wrist
- Wheel brakes



Item #	Height Stowed	Lifting Height	Capacity (lbs.)
GNGH3.8	3' 5"	12' 5.6"	300
GNGH5.6	4' 6"	18' 4.5"	250



SUMNER
Material Lifts
Series 2100

- 650 lb. capacity
- Rolls through standard doorways & tail gates
- Loading Bar - great for overhead cranes
- Reversible forks
- Plunger pins for quick readjustment and compact storage
- Lockable, 5" polyurethane casters
- Load cable feeds inside mast (no more exposed cable just inches away from operator's face)



Item #	Model #	Max. Height	Lifting Cap. (lbs.)
--------	---------	-------------	---------------------

Series 2100 Contractor Lifts

SU783650	2112	13'1"	650
SU783651	2118	18'6"	650
SU783652	2124	23'11"	650



LIFT-ALL®
Ratchet Tie Downs

Polyester

- Two piece assemblies with one fixed length of webbing and one adjustable length of webbing

Item #	Size	Hook Type
LF61001	2" x 27'	Flat
LF26422	2" x 27'	U
LF6100-00291	2" x 40'	Flat



LIFT-ALL®
Nylon Web Slings

Eye and Eye

- Red core yarn warning system aids in the inspection process
- Tuff-Tag provides serial numbered identification for traceability & provides required OSHA information for the life of the sling, not just the life of the tag
- Yellow treatment for abrasion resistance and extended sling life
- Nylon stretches more to help avoid shock loading



Item #	Sling Size (in. x ft.)
--------	------------------------

1-Ply

LFEE1-801T-3	1 x 3
LFEE1-801T-10	1 x 10
LFEE1-802T-5	2 x 5

2-Ply

LFEE2-801-3	1 x 3
LFEE2-801-4	1 x 4
LFEE2-801-6	1 x 6
LFEE2-801-8	1 x 8
LFEE2-801-10	1 x 10
LFEE2-801-12	1 x 12
LFEE2-802-3	2 x 3
LFEE2-802-4	2 x 4
LFEE2-802-6	2 x 6
LFEE2-802-8	2 x 8
LFEE2-802-10	2 x 10
LFEE2-802-12	2 x 12
LFEE2-802-14	2 x 14
LFEE2-802-16	2 x 16
LFEE2-802-20	2 x 20
LFEE2-803-6	3 x 6
LFEE2-803-8	3 x 8
LFEE2-803-20	3 x 20
LFEE2-804-20	4 x 20

LIFT-ALL®

Ratchet Tie Downs

1" Wide Polyester

- Two piece assemblies with one fixed length of webbing and one adjustable length of webbing
- Ultimate strength - 2,100 lbs.
- Working load limit - 700 lbs.



Item #	Size (in. x ft.)	Hook Type
LF60101-8	1 x 8	U
LF60101-12	1 x 12	U
LF60101-16	1 x 16	U
LF6A103B	1 x 15	Coated Open Hook



LIFT-ALL®
Endless Flat & Round Sling



**Polyester
Tuflex**

Roundsling construction protects all load carrying core yarns from abrasion with an independent, woven jacket. Replacement is not necessary until the red striped white core yarns can be seen through holes in the jacket. When core yarns are visible, sling must be removed from service. Tuflex roundslings provide double wall protection for extended sling life.

- Transverse pick yarns position surface yarns and protect core yarns
- Woven surface yarns also protect core yarns carry no load while longitudinal core yarns carry 100% of load
- Red core warning yarns

Item #	Length (ft.)	Body Dia. Relaxed (in.)	Width at Load (in.)	Rated Capacity Vertical (lbs.)	Rated Capacity Choker (lbs.)	Rated Capacity V. Basket (lbs.)
LFEN30-4	4	5/8	1 1/8	2,600	2,100	5,200
LFEN30-8	8	5/8	1 1/8	2,600	2,100	5,200
LFEN2-802	10	5/8	1 1/8			

LIFT-ALL®
Vehicle Recovery Strap



Tow-All

- Aids in removing vehicles stuck in snow, mud, sand and ditches
- Made from strong durable Tuff-Edge II webbing with sewn eyes, lined with premium abrasion resistant webbing, on each end
- Attaches quickly to vehicle frames or towing hooks

Item #	Size (in. x ft.)	Rated Cap. (lbs.)	Breaking Strength (new) (lbs.)	Ply
LFTS1-80230	2 x 30	5300	16000	1
LFTS2-80230	2 x 30	10700	32000	2



COLUMBUS MCKINNON CORP.
Mini Ratchet Lever Hoist

Series 602/603

- Plated load chain
- Weston-type load brake
- Lightweight design weighs only 5 pounds for ease of operation and portability; use in confined conditions with one hand operation
- Free chaining feature serves to quickly attach the load



Item #	Rated Cap. (lbs.)	Standard Lift (ft.)
CM0210	550	5
CM0214	550	10
CM0215	1,100	5
CM0216	1,100	10



COLUMBUS MCKINNON CORP.

Lever Hoist

Series 653

- Ideal for construction and industrial applications
- High quality, rugged, steel tool for close quarter pulling, stretching, and hoisting applications
- Hardened steel load sharing gears
- Double pawl arrangement for assured load control
- Forged upper and lower hooks with heavy cast steel latches



Item #	Load Rating (tons)	Lift or Reach (ft.)	Level Pull to Life Rated (lbs.)
CM5310	3/4	5	33
CM5311	3/4	10	33
CM5312	3/4	15	33
CM5313	3/4	20	33
CM5328	1	10	44
CM5315	1 1/2	5	51
CM5316	1 1/2	10	51
CM5317	1 1/2	15	51
CM5318	1 1/2	20	51
CM5329	2	15	68
CM5320	3	5	77
CM5321	3	10	77
CM5330	6	5	77
CM5331	6	10	77
CM5332	6	15	77
CM5333	6	20	77

COLUMBUS MCKINNON CORP.

Wide Range Trolley

Series 633

- Rugged steel side plates formed to include bumpers and trolley guards
- Frames connected by steel equalizer pin, secured by two nuts on each side
- Universal tread flanged trackwheels equipped with shielded ball bearings
- Easy rolling on American standard shapes, wide flange shapes or patented rail



Item #	Rated Cap. (tons)	Depth of S-Beam (in.)	Flange Width (in.)	Tread Dia. (in.)
CM3302	1/2	3-15	2 1/2-5 5/8	2 9/32
CM3304	1	5-24	3-8	3 15/32
CM3306	2	5-24	3 5/8-8	3 15/16
CM3307	3	8-24	4-8	5 1/8



COLUMBUS MCKINNON CORP.

Hand Chain Hoists

Series 622



- Simple, efficient, economical design
- Equipped with hardened load chain for flexibility and long wear
- Compact design, low headroom and lightweight steel construction for easy installation, even in confined spaces
- Weston-type load brake requires no lubrication
- Hand wheel cover with guide slots minimizes jamming and slipping
- Standard hand chain drop is 2 feet less than lift

Item #	Rated Cap. (tons)	Standard Lift (ft.)	Chain Pull to Lift (lbs.)	Hand Chain to Overhauled to Lift 1' (ft.)
CM2202	½	8	53	29
CM2216	½	12	53	29
CM2208	½	15	53	29
CM2231	½	20	53	29
CM2263	½	30	53	29
CM2204	1	8	77	37
CM2217	1	12	77	37
CM2210	1	15	77	37
CM2262	1	20	77	37
CM2264	1	30	77	37
CM2206	2	8	82	80
CM2218	2	12	82	80
CM2213	2	15	82	80
CM2233	2	20	82	80
CM2272	2	30	82	80
CM2207	3	8	65	154
CM2230	3	12	65	154
CM2214	3	20	65	154
CM2209	5	8	105	147
CM2215	5	12	105	147
CM2234	5	20	105	147
CM2212	10	8	109	289

COLUMBUS MCKINNON CORP.

Manual Chain Hoists

Hurricane Series

- Unique Handwheel Cover - Handwheel cover rotates 360 degrees for hoist operation in any direction
- Unique Brake Design - Single disc brake does not incorporate ratchet, pawls, or pawl springs as on other hand chain hoists

Item #	Rated Cap. (tons)	Standard Lift (ft.)	Chain Pull to Lift (lbs.)	Hand Chain to Overhauled to Lift 1' (ft.)
CM5624	½	12	44	30





COLUMBUS MCKINNON CORP.
Pullers

- Tough aluminum alloy construction and powder coat finish
- Weatherproof for outdoor service
- Hoistaloy hardened steel link type load chain for strength, long wear life and flexibility
- Weatherized Weston-type automatic braking system for positive load control
- Easy, one-hand operation and control — only 58 pounds of
- Forged upper and lower hooks with latches standard
- Free wheeling for fast and easy attachment to load
- Upper and lower Latchlok hooks available for all capacities
- Optional Load Limiter protection device stops transmission of lever forces protecting against dangerous overload
- Optional Load Sentry warns of overload condition
- Optional anchor sling simplifies attachment to allow anchor hook to swivel in tight space applications (3/4 & 1 1/2 ton units only)
- Unlimited lift
- Lifetime warranty
- Made in U.S.A.



Item #	Rated Capacity (ton)
--------	----------------------

Standard Unit

CM4043	3/4
CM4045	1 1/2
CM4047	3
CM4050	6

Kit with Load Limiter

CM4190	3/4
CM4191	1 1/2
CM4191	3
CM4191	6

Kit with Load Sentry

CM4096	3/4
CM4098	1 1/2
CM4098	3
CM4098	6

Kit with Anchor Sling

CM4071	3/4
CM4072	1 1/2

COLUMBUS MCKINNON CORP.

Binders



Lever Type Load Binder

- All components are forged, no cast parts
- Lighter and stronger than cast binders

Item #	Working Load Limit (lbs.)	Handle Take up (in.)	Working Load Length (in.)
CM48304	2,600	3.75	11.25
CM48305	5,400	4.50	16.12
CM48406	9,200	4.75	16.62
CM48769	7,100	4.50	16.62

COLUMBUS MCKINNON CORP.

Binders



Tightener Load Binder

- Features a swivel hook for easier operation
- Either hook may be permanently attached to chain
- Rugged cast construction with formed hooks

Item #	Working Load Limit (lbs.)	Handle Take up (in.)
CM48979	175	2
CM48949	375	3

• Edge has many more options for hoists, pullers, slings and other lifting equipment.

• Call for help.



COLUMBUS MCKINNON CORP.

Binders

Ratchet Type Load Binder

- Each ratchet component is forged from pure alloy steel
- Handle is designed loose using self-locking one-way bolts allowing easy removal of unwanted debris
- Proof tested to 50% of the minimum breaking strength
- Gears are permanently welded to the barrel



Item #	Size (G30)	Size (G43)	Size (G70)	End Fittings	Working Load Limit (lbs.)
CM48364	1/4	-	Hook/Hook	2,600	4
CM48811	-	Eye/Eye (no hook)	5,400	8	
CM48363	-	Eye/Eye (no hook)	13,000	8	
CM48810	3/8	5/16	Hook/Hook	5,400	8
CM48360	3/8	Hook/Hook	7,100	8	
CM48365	3/8	5/16	Hook/Hook	5,400	8
CM48366	1/2	3/8	Hook/Hook	9,200	8
CM48367	5/8	1/2	Hook/Hook	13,000	

COLUMBUS MCKINNON CORP.

CM Super Strong Anchor Shackles

Screw Pin Type

- All shackle pins are forged from alloy steel, heat treated and tempered to give greater strength
- All shackles are marked with size (inches and millimeters) and working load limit in tons
- Ultimate strength equals 6 times working load limit
- Proof load equals 2.2 times working load limit
- Built-in distortion detectors (3/16" - 2")



Item #	Size (in.)	Work. Ld. Lmt. (tons)	P Dia. of Pin (in.)	L Inside Lgth. (in.)	B Inside Wdth. at Bow (min.) (in.)	R OD of Eye (max.) (in.)	W Wdth. Btwn. Eyes - (in.)	Desc.
CMM646P	1/4	3/4	5/16	1 1/8	3/4	7/8	15/32	Painted
CMM647P	5/16	1	3/8	1 1/4	13/16	1	17/32	Painted
CMM648P	3/8	1 1/2	7/16	1 7/16	15/16	1 1/8	2 1/32	Painted
CMM649P	7/16	2	1/2	1 11/16	1 1/16	1 1/4	3/4	Painted
CMM650P	1/2	3	5/8	1 7/8	1 3/16	1 3/8	1 3/16	Painted
CMM651P	5/8	4 1/2	3/4	2 3/8	1 1/2	1 7/8	1 1/16	Painted
CMM652P	3/4	6 1/2	7/8	2 13/16	1 3/4	2 1/8	1 1/4	Painted
CMM653P	7/8	8 1/2	1	3 9/16	2	2 3/8	1 7/16	Painted
CMM654P	1	10	1 1/8	3 3/4	2 5/16	2 5/8	1 11/16	Painted



COLUMBUS MCKINNON CORP.

Quick Links

- Application: Use as a repair link, connecting link, or attaching device



Item #	Work. Ld. Lmt. (lbs.)	Chain Size (in.)	Gap (in.)
CM81101	880	1/4	9/32
CM81201	1,540	5/16	3/8
CM81301	1,980	3/8	7/16
CM81501	3,300	1/2	19/32

COLUMBUS MCKINNON CORP.

G70 Grab Hooks

- Meets ASTM and NACM standards
- Designed specifically for transport grade 70 chain
- 4:1 design factor
- Not recommended for overhead lifting



Item #	Size	Working Load Limit (lbs.)
--------	------	---------------------------

Clevis Grab Hooks

CM62273	5/16	4,700
CM62373	3/8	6,600

Eye Grab Hooks

CM72197	5/16	4,700
CM71497	3/8	6,600

COLUMBUS MCKINNON CORP.

Grab Hooks

HERC-ALLOY 800®

- Quench and tempered alloy steel
- Fatigue rated
- Cradle design unique to CM



Item #	Size (in.)	Working Load Limit (lbs.)
--------	------------	---------------------------

Clevlok Grab Hook

CM659232	9/32	3,500
CM659235	3/8	7,100
CM659238	1/2	12,000
CM659239	5/8	18,100

Clevlok Cradle Grab Hook

CM659222	9/32	3,500
CM659225	3/8	7,100
CM659228	1/2	12,000
CM659229	5/8	18,100
CM659430	3/4	28,300

COLUMBUS MCKINNON CORP.

Sling Hooks

- Available with and without a latch
- Quench and tempered alloy steel
- 100% proof tested
- Fatigue rated



Item #	Size (in.)	Working Load Limit (lbs.)	Latch
--------	------------	---------------------------	-------

Clevlok Sling Hooks

CM658318	9/32	3,500	y
CM658338	9/32	3,500	n
CM658319	3/8	7,100	y
CM658339	3/8	7,100	n
CM658320	1/2	12,000	y
CM658340	1/2	12,000	n
CM658321	5/8	18,100	y
CM658341	5/8	18,100	n
CM658322	3/4	28,300	y
CM658342	3/4	28,300	n

Eye Sling Hooks

CM558544	7/32	2,100	y
CM458544	7/32	2,100	n
CM558322	9/32	3,500	y
CM458722	9/32	3,500	n
CM558325	3/8	7,100	y
CM458725	3/8	7,100	n
CM558328	1/2	12,000	y
CM458728	1/2	12,000	n
CM558329	5/8	18,100	y
CM458729	5/8	18,100	n
CM558330	3/4	28,300	y
CM458730	3/4	28,300	n
CM558332	7/8	34,200	y
CM458732	7/8	34,200	n
CM558333	1	47,700	y
CM458733	1	47,700	n
CM558335	1 1/4	72,300	y
CM458735	1 1/4	72,300	n



COLUMBUS MCKINNON CORP.

Connector Links Hammerlok



- Attaches chain to master link and hooks
- Quench and tempered alloy steel
- 100% proof tested
- Fatigue rated

Item #	Size (in.)	Working Load Limit (lbs.)
CM664028-2	5/32	3,500
CM664038-2	3/8	7,100
CM664050-2	1/2	12,000
CM664062-2	5/8	18,100
CM664075-2	3/4	28,300
CM664089-2	7/8	34,200
CM664100-2	1	47,700
CM664125-2	1 1/4	72,300

COLUMBUS MCKINNON CORP.

Mid-Grip Wire Rope Grips

- Double grip, double saddle wire rope clips allow full arc wrench swing for quicker installation, retightening or disassembly of nuts
- Unlike U-bolt type rope clips, Mid-Grip clips cannot be installed incorrectly with the saddle not on the live rope end



Item #	Size (in.)	Rope Turn-Back (in.)	Min. # of Clips	Torque (ft./lbs.)
CMM2247	5/16	5	2	30
CMM2248	3/8	5 1/2	2	45

COLUMBUS MCKINNON CORP.

Pike Poles Aluminum Handles

- Manufactured to withstand extensive use of handling timber in and around water
- All pike hooks are manufactured from a single piece of high carbon steel and drop forged
- Will not warp or break with continued use



Item #	Length (ft.)
CM10082	6
CM10002	8
CM10012	10
CM10022	12
CM10032	14
CM10042	16
CM10052	18
CM10062	20
CM10072	24



AMERICAN POWER PULL

Professional Power Pull

With Safety Latches

- Cable limiter; keeps two wraps of cable on the ratchet wheel
- One piece pulley wheel, for longer cable life

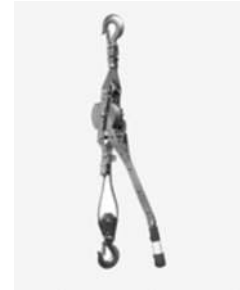

Item #	Leverage	Capacity (tons)	Pull (ft.)	Cable (in.)
PPS144	36:1	1	6	3/16
PPS72A	36:1	2	6	3/16

LUG-ALL

LUG-ALL CORPORATION

Cable Winch-Hoists

Aircraft Cable

- Aluminum alloy frame
- Swaged ball shank terminal locks cable securely in frame
- Hydraulically crimped copper sleeve on cable end
- Reversible handle-always a downward pull
- Self-storing aircraft cable
- Drop forged steel hooks



Item #	Cable Dia. (in.)	Cable Lgth.	Capacity (ton)
LU1000-15SH	3/16	16'	1/2
LU1500-25SH	5/32	26'	3/4
LU3000-10SH	7/32	11'6"	1 1/2
LU3000-30SH	7/32	31'6"	1 1/2
LU4000-20SH	1/4	22'	2
LU6000-15SH	5/16	18'	3

Telpro Inc.

TELPRO
Drywall Lift
Panellift®

The original Panellift® Model 138-2 is the industry's leading drywall lifter. Why struggle with wallboard when you can single handedly lift wallboard up to 11 foot walls and ceilings? Cradle tilts laterally 65 degrees for easy loading and for installation on walls and sloped ceilings. It also tilts longitudinally 10 degrees. Fast action, single stage winch with silent cam-lock brake easily lifts and lowers wallboard so you don't have to strain your back.



Item #	Sheet Size & Capacity	Max Standard Reach (ft.)	Reach With Extension 154	Reach With Extension 186 (ft.)	Net Weight (lbs.)
TE138-2	1 qty. up to 4' x 16'	11	12' 6"	15	100

TELPRO
6 Foot Extension

- Replaces the two 4 foot telescoping extensions on the 138-2 allowing the lift to reach 15 feet
- The extension will not work on 8 foot ceilings and does raise the loading height to 54 inches; the loader will not work with this extension



Item #
TE186

TELPRO
Drywall Cart
Troll®

The 1361 is more than just a drywall cart! It is truly multi-purpose. The open front lets one person load and unload without damaging the boards or your hands. The handles store for transportation and storage and also are used to create a flat bed cart. The 1270 has a 12 inch stacking space.



Item #
TE1361



WARNER TOOL
Drywall Stilts
EZ-Stride®

- Adjusts quickly and easily without tools
- Dual-spring action to make walking more natural
- Aluminum with cotton straps and heavy-duty spring clips
- Weight limit 225 lbs. with tools



Item #
WAR10230

WARNER TOOL
Drywall Bench
EZ-Stride®

- Made of lightweight, extruded aircraft aluminum with heavy welds
- Holds up to 450 lbs. with tools
- Bench top measures 9-1/2" wide and 48" long
- Folds to 6-1/2"x16"x48"



Item # Weight (lbs.)
WAR10329 36

WARNER TOOL
Extension Legs
EZ-Stride®

- Leg extension increases bench top height to 47"
- Flared to increase stability and minimize tipping



Item #
WAR10040

ENERPAC

ENERPAC
High Flow Couplers
3/8 Inch

- Standard equipment on most Enerpac cylinders
- Recommended for use on all Enerpac pumps and cylinders where space and porting permits
- Includes "2-in-1" dust cap for use on male and female coupler halves



Item #	Desc.	Max. Flow Cap.
ENC-604	Complete Set	2,500
ENCR-400	Female Half	2,500
ENCH-604	Male Half	2,500

ENERPAC

ENERPAC Hydraulic Cylinders

RSM Series Flat-Jac®

- Compact, flat design for use where other cylinders will not fit
- RSM-750, 1000 and 1500 have handles for easy carrying
- Mounting holes permit easy fixturing
- CR-400 coupler and dust cap included on all models*
- Single-acting, spring return



Item #	Cylinder Cap. (Tons)	Stroke (in.)	Collapsed Ht. (in.)	Outside Dia. D (in.)
ENRSM-50	5	.25	1.28	2.31 x 1.63
ENRSM-300	30	.50	2.31	4.63 x 3.75
ENRSM-500	50	.63	2.63	5.50 x 4.50

ENERPAC Single-Acting Cylinders

RC-Series

- Designed for use in all positions
- CR-400 coupler and dust cap included on all models
- Capacity: 5-100 tons
- Stroke: .63-14.25 inch
- Maximum Operating Pressure: 10,000 psi



Item #	Stroke (in.)	Collapsed Ht. A (in.)
ENRC-151	1.00	4.88
ENRC-251	1.00	5.50
ENRC-2510	10.25	14.75
ENRC-5013	13.25	18.13
ENRC-1006	6.63	14.06

ENERPAC Hydraulic Oil

Item #	Desc.
ENHF-100	1 Qt.
ENHF-101	1 Gal.
ENHF-102	5 Gal.



ENERPAC

Single-Acting Cylinders

RC-Series

- Designed for use in all positions
- High strength alloy steel for durability
- CR-400 coupler and dust cap included on all models
- Capacity: 5-100 tons
- Stroke: .63-14.25 inch
- Maximum Operating Pressure: 10,000 psi



Item #	Stroke	Cyl. Cap.	Coll. Ht. A	Wt.
ENRC-51	1.00	5	4.34	2.3
ENRC-101	1.00	10	3.53	4.0
ENRC-102	2.13	10	4.78	5.1
ENRC-104	4.13	10	6.75	7.2
ENRC-106	6.13	10	9.75	9.8
ENRC-1014	14.00	10	17.75	18.0
ENRC-156	6.00	15	10.69	15.0
ENRC-256	6.25	25	10.75	22.0

ENERPAC

Universal Hydraulic Tool Box

MS - Series

These universal sets include a pump, hose, cylinder, gauge and 24 attachments - enough to assemble numerous specialized tools. Includes a storage case. Capacity 2.5 tons.



Item #
ENMSFP-5

ENERPAC

Steel Hand Pumps

Two Speed

- Two-speed operation for reduced operator fatigue (except P-39)
- 4-way valving on the P-84 and P-464 for operation of double-acting cylinders
- External load release valve on remaining models for single-acting cylinder operation
- Internal pressure relief valves for overload protection
- Large oil capacities to power a wide range of cylinders or tools
- 10,000 psi pressure rating 2nd stage



Item #	Usable Oil Cap. (in.)
ENP-462	453



ENERPAC

ENERPAC
**6-Port Hexagon
Manifold**

- Plugs furnished for all ports 3/8"-18 NPTF

Item #

ENA-66

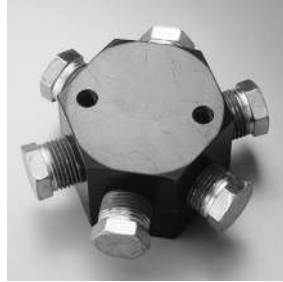

ENERPAC
**Lightweight
Hand Pumps**



Item #	Pump Type	Usable Oil Cap.
ENP-391	Single Speed	55 10,000
ENP-392	Two Speed	55 10,000

ENERPAC
Steel Hand Pumps



Item #	Pump Type	Usable Oil Cap.
ENP-80	Two Speed	134

ENERPAC
Spreader

- 1.0 tons

Item #

ENWR-5



ENERPAC
Cylinder

**Double-Acting
RR - Series**

- Collar threads, plunger threads and base mounting holes for easy fixturing (on most models)
- Baked enamel finish for increased corrosion resistance
- Removable hardened saddles protect plunger during lifting and pressing
- Built-in safety valve prevents accidental over-pressurization
- CR-400 couplers included on all models



Item #

ENRR-506



COOPER HAND TOOLS

**Cable Wire
Campbell®**

- High strength cable with a galvanized finish
- Campbell's wire rope is 6 x 19 fiber core construction and treated with a rust prohibiting oil



Item #	Size (in.)	Type Const.	Feet Per Reel	Working Load Limit (lbs.)	Working Load Limit (kg)
CG7000427	1/8	7 x 7	500	340	154
CG7000627	3/19	7 x 19	250	840	381
CG7000827	1/4	7 x 19	250	1400	635

Cable

COOPER HAND TOOLS

Binder Chain

**Transport
Campbell® Chain**

A complete line of tie-down chains. All chains listed meet latest DOT regulations. For heavy-duty trucking. All with Clevis grab hooks.

- Chain grade System 7
- Chain length 20 feet; Link Size: 5/16



Item #	Size (in. x ft.)	Work. Ld. Lmt. (lbs.)	Wt
CG0513574	5/16x20	4700	23
CG0513665	3/8x20	6600	0



COOPER HAND TOOLS
High Test Chain
Campbell®



- Designed for use in load binding, towing, logging, and other applications requiring high strength
- Standard material: Carbon steel
- Working Load Limit: 3900 lbs.

Item #
CG0180512

COOPER HAND TOOLS
Proof Coil Chain



Zinc Plated
Campbell®

- Excellent general-purpose chain of standard commercial quality
- Frequently used for fabricating tow chains, binding or tie-down chains

Item #	Material Dia. (in.)	Working Load Limit (lbs.)
CG0143226	.16	400
CG0143326	.21	800
CG0143426	.26	1300

COOPER HAND TOOLS
Wire Rope Clips

Galvanized
Campbell®



- Standard finish: Galvanized

Item #	Size (in.)
CGT7670419	3/32-1/8
CGT7670429	3/16
CGT7670439	1/4

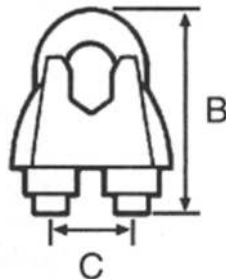

COOPER HAND TOOLS
Cable Ferrules
Campbell®

- Made from aluminum



Item #	Desc.	Dim. for Cable in. (mm)
CGB7675324	Cable Ferrules (2) and Stops (2)	1/8 (3)
CGB7675344	Cable Ferrules (2) and Stops (2)	3/16 (5)
CGB7675354	Cable Ferrules (2) and Stops (2)	1/4 (6)

COOPER HAND TOOLS
Load Binders

Ratchet Type
Campbell®



- Ratchet load binder
- To tighten chain, typically for cargo securement
- Meets US DOT 393.100 -393.102 requirements for use with chain
- Ratchet lever
- For Chain Size/Grade: 3/8 in./70 and 1/2 in./43
- Working Load Limit: 9200 lbs.
- Take-Up: 8"

Item #
CG6207803

COOPER HAND TOOLS
Swaging Tool
Campbell®

- Used on Rope Size: 1/8" to 3/16"
- Material Finish: Steel
- Uses: For swaging ferrules onto wire rope or cable



Item #
CG7679038



COOPER HAND TOOLS

Load Binders

Campbell® Chain

- System 4 binders use carbon hooks and system 7 use alloy hooks



Item #	For Chain Size and Type in. (mm)	Desc.	Take-Up in. (mm)	Working Load Limit lbs. (kg)
CG6203604	5/16 (8) Sys. 7, 3/8 (10) Sys. 4	Doub. Swivel, Lever, Red, Imported	4 1/2 (114)	5400 (2450)

COOPER HAND TOOLS

Wire Rope Thimbles

Zinc Plated Campbell®



- Standard Finish: Galvanized

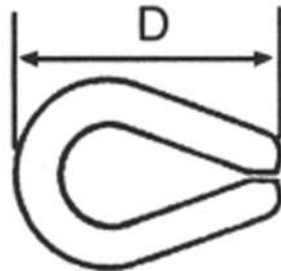

Item #	Size (in.)	Size (mm)	Dim. D in. (mm)
CGT7670609	3/32-1/8	2-3	1 1/4 (44)
CGT7670619	3/16	5	1 3/4 (44)
CGT7670629	1/4	6	1 7/8 (48)



HILMAN, INC.

Hydraulic Toe jacks

- Easy to use hydraulic jacks mean effort-less lifting of heavy machinery and equipment, high enough to slide a set of Hilman Rollers underneath to move it wherever you want to go



Item #	Cap (tons)
HIHTJ-10	10

HILMAN, INC.

Rigger Kits

With Steel Case

- Riggers kits 3 and 8 tons
- Limitless variety of uses, they provide the ability to move up to 3 tons or 8 tons
- Kits contain two steering handles and four padded rollers, which are offered either with all four swivel tops, or with two swivel and two rigid tops
- Sturdy steel carrying cases



Item #	Desc.	Wt
HIKRS-8-4S	Four #2-SP Rollers, Two #8-KH Kit Size Handles in Kit, or Two #H36T 36 in. Handles in Set	85

HILMAN, INC.

Heavy Moving Rollers

Kits & Sets FT Series

Everything required to make heavy moves up to 60 tons is included in Hilman's Deluxe Kits and Economy Sets! Both include four swivel locking Hilman Rollers with either padded or diamond steel tops and two steering handles; four preload pads are also included with rollers having the SLD style top; Sets contain full length steering handles; Kits contain knock down handles in two sections to fit into a sturdy steel storage case. Kit cases are lockable and have sturdy lifting grips for easy handling, providing protection from exposure and theft, while assuring all rollers are there when a heavy move needs to be made. Each kit or set provides the necessary gear to tackle a moving project up to that respective capacity.

- No. of rollers: 4 swivel-locking
- Swivel/Locking pads



Item #	Capacity (ton)	Pad Surface	Wt. (Lbs.)
HIKRS-15-SLD	15	Diamond Steel Grid	196
HIKRS-30-SLD	30	Diamond Steel Grid	208
HIKRS-40-SLD	40	Diamond	212
HIKRS-60-SLD	60	Diamond	252

JET

WHM TOOL GROUP
Heavy-Duty Bottle Jacks

JET



- Robotically welded base and cylinders
- Chromed pump piston and ram for added rust resistance
- Works in upright, angle or horizontal positions
- Pump handle included with all models
- Complies with ANSI/ASME PALD-1 and B30.1 standards

Item #	Stock No.	Rated Cap'y (ton)	Closed Ht (in.)	Piston Ht (in.)	Head Screw (H/in.)	Max Ht (in.)	Base Size (LPW/in.)
JEJBJ-12-1/2L	JBj-12TL	12	6¾	3¾	3	13¾	6½ x 4½

WHM TOOL GROUP

Premium Pallet Truck

- Premium quality 6,000 lbs. capacity pallet truck with robotic welds
- Easy-to-use with large ergonomic handle, fingertip controls and 200° turning radius
- Handle returns to upright position when not in use
- Articulating axle maintains wheel contact on uneven floor surfaces
- One-piece cast pump features hardened and chromed piston and ram with high quality seals
- Pump also features step-less lowering valve, allowing you to control the rate of descent, top-of-stroke and safety overload bypass system
- Single point replacement valve makes servicing or rebuilding easy
- Solid steel lifting rods, no periodic adjustment required
- Rounded fork tips with nylon rollers for trouble-free pallet entry and exit
- Polyurethane over aluminum steer wheels with lifetime lubricated bearings
- Nylon load wheels with lifetime lubricated bearings



Item #	Model No.	Wt
JEPT-2748W	140075	200



AMERICAN POWER PULL

Heavy-Duty Hand Trucks Appliance Dolly

- Securing strap to prevent slipping
- Solid rubber tires
- Crawler tread to help move load
- 1000 Lb. capacity
- Ratchet tension securing strap
- Ball bearing wheels



Item #
PP5500

AMERICAN POWER PULL

Heavy-Duty Hand Trucks

- 550 lb. capacity
- Durable tube construction
- Perfect for carrying large feed bags
- Approximate Dimension: 18"x20"x20"
- Nose Plate: 7-1/2"x14"
- Wheels: 10"



Item #	Desc.
PP5400	Solid Wheel
PP5419	Pneumatic Wheel



RUBBERMAID COMMERCIAL PRODUCTS

Heavy-Duty Dolly

- One piece high impact molded polyethylene
- 4" non-marking double ball race-way casters
- Non marking padded deck
- Size: 30"x18"
- Capacity: 1000 lbs.



Item #
RB9T55



RUBBERMAID COMMERCIAL
PRODUCTS

Triple® Trolley

- Sturdy structural foam deck won't rust, dent, chip or peel
- Non-skid platform surface helps prevent load shifting
- Tough plastic construction is easy on walls and doors
- Three-position user-friendly handle lets users push, pull or fold flat for use as a dolly
- Casters are non-marking



Item #	Size (in.)	Capacity (lbs.)
RB4401-00	33½x20½	500

RUBBERMAID COMMERCIAL
PRODUCTS

Heavy-Duty Utility Carts

- Sturdy structural foam construction won't rust, dent, chip or peel
- Standard cup holder and storage compartments on top shelf
- Rounded corners protect walls and surroundings
- Lightweight and maneuverable
- 5" diameter, non-marking casters (two fixed, two swivel)



Item #	Desc.	Size (in.)	Capacity (lbs.)	Wt
RB4500	2 Shelf (Small)	39x17½x33¼	500	34.4
RB4520	2 Shelf (Med)	45¼x25¾x33¼	500	44.6

RUBBERMAID COMMERCIAL
PRODUCTS

Structural Foam Tilt Truck

Standard Duty

- Fits through standard commercial and onto elevators easily
- Non-marking casters reduce touch-up cleaning
- Optional domed lid available



Item #	Dimension (in.)	Size (cu. yd.)	Wt. Cap. (lb.)
RB1013	64½x30¾x38	¾	1000

Domed Lid

RB1028	61x31¾x8¾
--------	-----------

RUBBERMAID COMMERCIAL
PRODUCTS

Molded Tilt Trucks

- Sturdy, plastic construction weighs much less than metal
- Easy to handle and maneuver through doorways and elevators
- Inset wheels on 1/2 cu. yd. and 1 cu. yd. models protect walls, fixtures and patrons
- Optional domed lids available



Item #	Dimension (in.)	Size (cu. yd.)	Wt. Cap. (lb.)	UoM
RB1314	72¼ x 33½ x 43¾	1	750	Ea

Domed Lid

RB1317	Fits 1314
--------	-----------

• Call Edge for other material handling needs.

• We also sell floor protection, tarps, trash bags, gloves, safety glasses, masks, hard hats, demo tools and much more!

GOLO POWER WINCH

GOLO
Electric Winch



Power Winch Designation Code:

- Winch Series: 1200=1200
- Voltage: 15=115 volt
- Switch Control: S=Standard(mounted on winch), R=Remote (10-ft. remote cord,additional lengths available), MO=Momentary Selector Switch, Ma=Maintained Selector Switch
- If Double Drum is required add a D before model # (Ex. D 12-15 RMO)

Important:

- First cable layer should have at least the first five wraps not in use
 - Each additional cable layer reduces capacity
 - Block and tackle arrangement (use double line only): doubles capacity and cable on drum but reduces line speed by one-half
- Cable On Drum, Cable Dia. (in.) x Drum Capacity (ft.) x Breaking Strength (lbs.):
- 1/8 x 512 x 2000
 - 5/32 x 325 x 2800
 - 3/16 x 215 x 4200
 - 7/32 x 165 x 5600
 - 1/4 x 135 x 7000
 - Galvanized aircraft cable, 7 x 19, is recommended for strength and flexibility

Important:

- Cordem specifies a minimum cable safety factor of 5:1 and a safety latch on all hooks

Item #	Lift Capacity (lbs.) 1st Drum Cable Layer	Lift Capacity (lbs.) Full Drum	Line Speed (ft./min.) In 1st Drum Cable Layer	Line Speed (ft./min.) In Full Drum	Line Speed (ft./min.) Out 1st. Drum Cable Layer	Line Speed (ft./min.) Out Full Drum	Line Speed (ft./min.) No Load 1st. Drum Cable Layer	Line Speed (ft./min.) No Load Full Drum
GO12-15 RMO	1200	700	17	25	37	54	28	41
GO12-15 RMA	1200	700	17	25	37	54	28	41

JOBBOX

JOBBOX
Tool Box
On-Site Storage
Jobbox



- Bolt cutter free locking system
- Tri-Hide exterior enamel coating provides maximum rust and corrosion resistance
- 16-gauge reinforced steel construction
- Site-Vault™ Security System - 3-point lock engagement is virtually impossible to bend or pry open

Item #	L x W x H (in.)	Cubic ft.	Shipping Weight (lbs.)	Wt
Welder's Box & Small Chests				
DB650990	30x16x12	3.3	33	37
DB651990	31x18x15	4	70	0
Heavy-Duty Chests				
DB1652990	36x20x23¾	8.3	98	
DB1653990	42x20x23¾	9.3	118	
DB1654990	48x24x27¾	15.4	148	
DB1655990	60x24x27¾	19.3	182	
DB1656990	48x30x33¾	24.3	190	
DB1658990	72x24x27¾	23.2	220	



JOBBOX
Tool Box

**Lockable Sloped Lid
Chests for Jobsite Storage**
Jobox®



- Full length piano hinge ensures smooth and consistent operation
- Full width shelf separates and stores smaller items

Item #	L x W x H (in.)	Cubic ft.	Shipping Weight (lbs.)	Wt
DB1680990	60x30x39½	30.7	243	216

JOBBOX
Drop-Front Top Chest

High-Capacity

- 37% more capacity for storing taller, bulkier equipment
- Extra wide, low-incline ramp supports up to 1,000 lbs for safe and easy loading and unloading
- Installs inside 14 gauge steel housing to prevent being pried, cut or knocked out during break in



Item #	L x W x H (in.)	Cubic ft.	Shipping Weight (lbs.)
DB1657990	60x31x45	41.5	340

JOBBOX
Drop-Front Top Chest

- Two deep storage bins located on both side walls
- Bottom shelf on most models lifts up for easier loading and unloading of large items in the bottom
- Gas springs assist with opening and closing the door; they are embedded in the side walls and protected from damage and jamming - guards reinforce the side walls
- Drop-down tapered ramp is reinforced to support heavy loads and locks with two sliding gate bolts on the inside; makes it easy to roll or put heavy items in the bottom of the box



Item #	L x W x H (in.)	Cubic ft.	Shipping Weight (lbs.)
DB1683990	60x30x50	47.5	405

JOBBOX
Tool Box

**Lockable Piano Boxes
for Jobsite Storage**

Jobox®

- Two deep storage bins located on both side walls
- Bottom shelf on most models lifts up for easier loading and unloading of large items in the bottom
- Gas springs assist with opening and closing the door



Item #	L x W x H (in.)	Cubic ft.	Shipping Weight (lbs.)
DB1688990	60x31x38	34.5	283
DB1682990	60x31x50	47.5	326
DB1681990	48x31x50	38	286

JOBBOX
Field Office

Jobox®

- Can be propped into a flat working surface and provides pad-lockable storage underneath
- Provides hanging storage of smaller items, shelf space for large objects and bins to hold small tools and supplies
- Stores items up to 60" in length and is opened by a lanyard inside the lower cabinet for additional security
- Pin secures open door support arm to bracket and side wall to prevent accidental door closing



Item #	L x W x H (in.)	Cubic ft.	Shipping Weight (lbs.)
DB1674990	63x42x80	100	660

JOBBOX
Drawer Cabinet

Jobox®

- Three 2-1/2" deep drawers have 75 lb. load capacity
- Five 5-1/2" deep drawers have 125 lb. load capacity
- 4-1/2" deep top shelf and three 3" deep shelves on each door
- Recessed lifting handles
- Hand or foot-operated door latch release system
- Drawers fully extend for easy access



Item #	L x W x H (in.)	Cubic ft.	Shipping Weight (lbs.)
DB1679990	24x60½x53¼	58.7	610

JOBBOX

JOBBOX Rolling Work Bench Jobox®



- Drawers and shelves are easy to move to match your requirements; add additional drawers or shelves as needed
- 18 Ga. steel drawers have heavy-duty ball bearing glides, Model 678990 has 125 lb. capacity drawers; other models have 75 lb. capacity drawers
- Available with 4" or 6" casters; includes two fixed and two lockable swiveling casters

Item #	Desc.	L x W x H (in.)	Cubic ft.	Shipping Weight (lbs.)
DB678990	6 Drawers, 1 Shelf, 6" Casters	49 ⁷ / ₈ x26 ⁷ / ₈ x40 ⁵ / ₈	24.6	342
DB676990	4 Drawers, 1 Shelf, 4" Casters	43 ⁷ / ₈ x26 ⁷ / ₈ x38 ¹ / ₂	21.7	294
DB675990	2 Drawers, 2 Shelves, 4" Casters	43 ⁷ / ₈ x26 ⁷ / ₈ x38 ¹ / ₂	21.7	266.5

JOBBOX Gang Box

Heavy-Duty Cabinets Jobox®



- Two-door models provide built-in door shelves for small items
- Charge batteries overnight on site: Access holes are located in the side walls

Item #	Desc.	L x W x H (in.)	Cubic ft.	Shipping Weight (lbs.)	Wt
DB694990	Two Doors	60 ¹ / ₈ x24 ¹ / ₄ x60 ³ / ₄	47.5	379	384
DB695990	Four Doors, Both Sides	60 ¹ / ₈ x32 ¹ / ₄ x60 ³ / ₄	63.7	523	0
DB697990	Two Doors, Open Side	60 ¹ / ₈ x24 ¹ / ₄ x60 ³ / ₄	47.5	366	0
DB698990	Two Doors	60 ¹ / ₈ x30 ¹ / ₄ x60 ³ / ₄	58.7	436	0

JOBBOX Rolling Clam Shell Cabinet



- Moveable storage: Eight 4" heavy-duty casters open and close cabinet, hinge stop prevents cabinet from fully opening and reduces potential for tipping, high center handles for opening, closing and moving cabinet

Item #	L x W x H (in.)	Cubic ft.	Shipping Weight (lbs.)
DB692990	62 ¹ / ₂ x30x63 ¹ / ₂	58	472

JOBBOX Vehicle Underbed Boxes



Steel

- 3/4" wide rain gutter surrounds the door opening to channel moisture around the opening to protect the contents
- T-handle draws the door tight against the weather stripping and locks at 3-points; reinforced cam lock for superior security

Item #	L x W x H (in.)
--------	-----------------

Black

DB733980	24x18x18
DB734980	30x18x18
DB735980	36x18x18
DB738980	48x18x18



JOBBOX
Tool Chest Trays

Removable

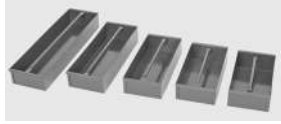

- Removable trays with built-in handles for storing small parts or tools
- Trays are made of 16-gauge steel; hemmed edges add strength and eliminate sharp edges
- Small parts storage trays for chests
- Heavy-duty, durable design

Item #	Fits Chest #	L x W x H (in.)
DB628990	1-652990, 1-653990	18 ³ / ₁₆ x8x4
DB627990	1-656990	28 ³ / ₁₆ x8x4
DB626990	1-654990, 1-655990, 1-658990	22 ³ / ₁₆ x8x4
DB624990	651990	16 ³ / ₁₆ x8x4
DB620990	652990	15 ³ / ₁₆ x8x4



KNAACK® JOBSITE STORAGE
EQUIPMENT

**Jobsite Storage
Chests**

STORAGEMASTER®

- Storage Capacity: 57.5 cu. ft.
- Model 91 has 48" wide fold down ramp to make loading large, bulky items easy



Item #	Height (in.)	Length (in.)	Width (in.)	Wt
KN90	49	72	30	380
KN91	49	72	30	409

KNAACK® JOBSITE STORAGE
EQUIPMENT

Welders Chests

JOBMASTER®

- Storage Capacity: 3.3 cu. ft.



Item #	Storage Cap (cu. ft.)	Height (in.)	Length (in.)	Width (in.)	Wt
KN28	2.3	12	28	12	32
KN30	3.3	12	30	16	38

KNAACK® JOBSITE STORAGE
EQUIPMENT

**Jobsite Storage Chests
STORAGEMASTER®**

- Watchman IV Lock System
- Gas spring assisted lid
- Powder coat finish



Item #	Storage Cap.	Height (in.)	Length (in.)	Width (in.)	Wt.
KN89	47.8	49	60	30	337
KN79	38.2	49	48	30	287
KN69	35.3	34	60	30	282

KNAACK® JOBSITE STORAGE
EQUIPMENT

**Jobsite Storage Chests
JOBMASTER®**

- Watchman IV Lock System (1 #5 Masterlock)
- 3 point latching (#KN42 and larger)
- Heavy-duty hinges
- Power Pass™ - Electrical pass-through grommet (#KN42 and larger)
- Reinforced lock housing
- Powder coat finish



Item #	Cubic ft.	Height (in.)	Length (in.)	Width (in.)	Wt.
KN4830	25.25	29	48	30	194
KN4824	16	23	48	24	158
KN2472	24.5	23	72	24	216
KN60	20.25	23	60	24	190
KN42	9	18	42	19	114
KN36	7	16	36	19	97
KN32	5	13	32	19	84

KNAACK® JOBSITE STORAGE
EQUIPMENT

**Rolling Cabinet
JOBMASTER®**

- Storage Cap: 60.9 cu. ft.
- Load Cap: 1200 lbs. evenly distributed



Item #	Height (in.)	Length (in.)	Width (in.)	Load Capacity (lbs.)	Wt
KN100	65	60	15	1200	470



KNAACK® JOBSITE STORAGE EQUIPMENT

Accessory Trays

KNAACK® Jobsite Storage Equipment

- Lift out tray to keep tools organized and ready to go



Item #	Fits	Height (in.)	Length (in.)	Width (in.)	Wt	Dividers
KN51	28	3	27 $\frac{1}{2}$	11	No	
KN31	4830	4	27 $\frac{1}{2}$	8	11	No
KN21	2472, 4824,60	4	21 $\frac{1}{2}$	8	9	No
KN41	32, 36, 42	4	16 $\frac{1}{2}$	8	7	No
KN11	-	3 $\frac{3}{4}$	18	10	11	Yes
KN10	-	3 $\frac{3}{4}$	18	10	11	No

KNAACK® JOBSITE STORAGE EQUIPMENT

Half-Width Shelf Cabinets

JOBMASTER®

- One-time lock installation means no downtime replacing locks
- Convenient foot latch opens the doors when you step on it, allowing hands-free operation
- Deep door design for maximum pry-bar resistance and better tool organization
- Ability to add accessory door shelves
- KN111 - Open right side w/ top shelf
- Picture of KN112 shown



Item #	Storage Cap (cu. ft.)	Height (in.)	Length (in.)	Width (in.)	Wt
KN112	54.9	60	30	670	
KN111	47 $\frac{1}{2}$	60	24	385	

KNAACK® JOBSITE STORAGE EQUIPMENT

Mobile Heavy-Duty Field Station

KNAACK® Jobsite Storage Equipment

- Engineered to be used at strategic points around a large jobsite for storing and reviewing drawings as well as locking up tools
- Powder coat finish



Item #	Storage Cap.	Height (in.)	Length (in.)	Width (in.)	Wt.
KN119	115.2	82	60	42	624

KNAACK® JOBSITE STORAGE EQUIPMENT

Mechanics Chest

STORAGEMASTER®

- Red mechanics bench
- 3 - 1" deep drawers
- 4 - 2-1/2" deep drawers
- 1 - 6" deep drawer
- 1 - 1" deep shelf
- Load Capacity: 1,000 lbs.



Item #	Height (in.)	Length (in.)	Width (in.)	Wt
KN63	30 $\frac{1}{2}$	46 $\frac{1}{4}$	25	352

KNAACK® JOBSITE STORAGE EQUIPMENT

Slant Top Storage Chest

STORAGEMASTER®

- Storage Capacity: 31 cu. ft.



Item #	Height (in.)	Length (in.)	Width (in.)	Wt
KN3068	37	60	30	265

KNAACK® JOBSITE STORAGE EQUIPMENT

Rolling Work Bench

JOBMASTER®

- 4" casters included
- Welded shelf on left side for strength
- Load capacity: 800 lbs.



Item #	Height (in.)	Length (in.)	Width (in.)	Wt
KN44	33 $\frac{1}{2}$	40 $\frac{3}{4}$	25	240

KNAACK® JOBSITE STORAGE EQUIPMENT

Hand Tool Boxes

18 Ga. Steel

KNAACK® Jobsite Storage Equipment



Item #	Storage Capacity (cu. ft.)	Height (in.)	Length (in.)	Width (in.)	Wt
KN741	.75	8	20	8	17
KN742	1	9	22	9	22
KN743	1.5	9 $\frac{1}{2}$	26	11	27



KNAACK® JOBSITE STORAGE
EQUIPMENT

Wall Cabinet JOBMASTER®

- Storage Capacity: 10.7 cu. ft.



Item #	Height (in.)	Length (in.)	Width (in.)	Wt
KN33	36	32	16	81

KNAACK® JOBSITE STORAGE
EQUIPMENT

Portable Worktable KNAACK® Jobsite Storage Equipment



Item #	Height (in.)	Length (in.)	Width (in.)	Wt
KNR-72	36	71½	27½	136



EZ ROLL, INC.

Tool Box Casters

- Industrial grade
- Polyolefin wheels designed for hard impacts and heavy loads
- Non-marking for floor protection
- Resistant to most oils, chemicals, gasoline, acids and grease



Item #	Desc.	Capacity Per Set (lbs.)
EZ40-PO-SET	4" - 2 swivel, 2 rigid	2400
EZ50-PO-SET	5" - 2 swivel, 2 rigid	3200
EZ60-PO-SET	6" - 2 swivel, 2 rigid	4000
EZ60-PO-SET-SB	6" - 2 swivel, 2 rigid w/brakes	4000
EZ66-PO-SET	6" - 4 swivels	4000



RUBBERMAID COMMERCIAL
PRODUCTS

Tool Boxes

- Professional-grade tool boxes for commercial/industrial use
- Made of sturdy structural foam construction that won't rust, dent, chip, or peel
- Removable trays provide added compartmentalized storage area
- Can be padlocked for security
- Impact resistant, water resistant, and easy to clean
- Rust resistant, heavy-duty metal latches



Item #	Size (in.)	Capacity (lbs.)
RB7802-00	26x11½x11½	60
RB7804-00	36x18½x20½	200

RUBBERMAID COMMERCIAL
PRODUCTS

Deluxe Carry Caddy

- Heavy-duty caddy conveniently fits on cleaning and housekeeping carts
- Securely holds up to eight 32 oz. spray bottles and other common cleaning tools
- Ergonomic handle design provides comfortable fit
- Size: 15"x10.9"x7.4"



Item #
RB3154-06



WEATHER GUARD® TRUCK & VAN EQUIPMENT

Aluminum Saddle Box Low Profile

WEATHER GUARD® Truck Equipment

- Dimensions: H: 15" W: 20-1/4" L: 71-1/2"
- Weight: 80 lbs.
- Cubic feet: 8.8
- Fits: Most full size pickup trucks
- Accessories: Level storage, tray
- ARMOR TUF® Powder Coat
- EXTREME PROTECTION® lock
- Corner support channels



Item #	Finish*
KN121-0-01	Aluminum Diamond Plate

* Also available in Black finish



WEATHER GUARD® TRUCK & VAN EQUIPMENT

Saddle Box

Full-Size Low-Profile

WEATHER GUARD® Truck Equipment



- Dimensions: H: 15" W: 19-7/8" L: 71-1/2"
- Cubic feet: 11.3
- Fits: Most full size pickup trucks
- ARMOR TUF® powder coat
- Low Profile box: features reduced cover clearance for unobstructed view

Item #	Finish*
KN127-0-02	Aluminum Diamond Plate
KN126-3-02	White Steel

**Also available in black aluminum Diamond Plate and black steel finish*

WEATHER GUARD® TRUCK & VAN EQUIPMENT

Full-Size Extra Wide Saddle Box

WEATHER GUARD® Truck Equipment



- Dimensions: H: 18-1/2" W: 27-1/2" L: 71-1/2"
- Cubic feet: 15.3
- Fits: Most full size pickup trucks
- ARMOR TUF® Powder Coat

Item #	Finish*	Ship Weight (lbs.)
KN117-0-02	Aluminum Diamond Plate	101
KN116-3-02	White Steel	157

** Also available in black finish*

WEATHER GUARD® TRUCK & VAN EQUIPMENT

Full-Size Extra Wide Cross Box

WEATHER GUARD® Truck Equipment



- Dimensions: H: 18-1/2" W: 27-1/4" L: 71-1/2"
- Weight: 92 lbs.
- Cubic feet: 15.3
- Fits: Most full size pickup trucks
- Accessories: Powder coated steel divider tray
- Allows for Lo-Side and Super-Lo boxes to be added
- ARMOR TUF® Powder Coat

Item #	Finish*
KN114-0-01	Aluminum Diamond Plate

** Also available in black aluminum Diamond Plate and white steel finish*

WEATHER GUARD® TRUCK & VAN EQUIPMENT

Pork Chop Box

Steel

WEATHER GUARD® Truck Equipment



- Dimensions: H: 19-1/2" W: 13-1/2" L: 46-3/4"
- Weight: 66 lbs.
- Cubic feet: 3.4
- Over the wheel mounting maximizes the storage space in the truck bed

Item #	Finish*	Installation
KN162-3-01	White Steel	Driver Side
KN163-3-01	White Steel	Passenger Side

** Also available in chrome and black Armor Plate aluminum finish*

WEATHER GUARD® TRUCK & VAN EQUIPMENT

All Purpose Chest

Aluminum

WEATHER GUARD® Truck Equipment



- Dimensions: H: 19-1/4" W: 20" L: 62"
- Weight: 57 lbs.
- Cubic feet: 13.1
- 90° cover opening for easy access
- Offset hinge design allows for zero clearance when the back of the box is placed tight against the cab of a pickup bed
- ARMOR TUF® Powder Coat

Item #	Finish*
KN664-0-01	Aluminum Diamond Plate

**Also available in black armor plate aluminum and white and black steel finish*

WEATHER GUARD® TRUCK & VAN EQUIPMENT

All Purpose Chest

Steel

WEATHER GUARD® Truck Equipment



- Dimensions: H: 19-1/4" W: 20" L: 62"
- Weight: 115 lbs.
- Cubic feet: 13.1
- 90° Cover opening for easy access
- Offset hinge design allows for zero clearance when the back of the box is placed tight against the cab of a pickup bed
- ARMOR TUF® Powder Coat

Item #	Finish*
KN665-3-01	White

**Also available in chrome and black aluminum Diamond Plate and black steel finish*



WEATHER GUARD® TRUCK & VAN EQUIPMENT
All Purpose Chest

Aluminum

WEATHER GUARD® Truck Equipment

- Fits: All mini pickups
- Accessory: Model 613-3 accessory tray may be ordered separately
- Rotary style latch mechanism keeps the cover tight against the weather seal
- Angled body design is ideal for use with fifth wheel and goose neck trailer applications
- Back of the chest can be placed tight against the front of the pickup bed because zero clearance is needed for opening the cover
- ARMOR TUF® Powder Coat



Item #	Finish*
KN674-0-01	Aluminum Diamond Plate

***Also available in black aluminum Diamond Plate and white steel finish**

WEATHER GUARD® TRUCK & VAN EQUIPMENT

Super-Lo-Side Box

Steel

WEATHER GUARD® Truck Equipment

- Use: Separately or in combination with cross or saddle boxes



Item #	Height (in.)	Length (in.)	Cubic ft.	Ship Weight (lbs.)	Finish*
KN176-3-01	14	60¾	6.5	94	White
KN186-3-01	13	46¾	4.5	72	White

*** 176-3-01 also available in black steel finish**

WEATHER GUARD® TRUCK & VAN EQUIPMENT
Super-Lo-Side Box

Steel

WEATHER GUARD® Truck Equipment



- Dimensions: H: 11-3/4" W: 19-1/4" L: 44-1/4"
- Weight: 41 lbs.
- Cubic feet: 3.1
- Greater rear-window visibility
- Extra-wide design increase storage space
- Matches profile of full and compact sized aluminum low profile saddle boxes
- Made of heavy-gauge aluminum for years of dependable durability
- Quick and easy installation
- ARMOR TUF® Powder Coat

Item #	Desc.	Finish*
KN180-0-01	Driver Side	Aluminum Diamond Plate
KN181-0-01	Passenger	Aluminum Diamond Plate

*** Also available in black**

WEATHER GUARD® TRUCK & VAN EQUIPMENT

Transfer Tank

WEATHER GUARD® Truck Equipment



- Designed to transport diesel fuel only
- Fits with most bed liners and with WEATHER GUARD® Cross and saddle Boxes
- Interior baffle design reduces fuel movement
- Lockable, vented filler cap prevents excessive pressure buildup
- 2" I.D. filler neck is threaded to accept standard 2" threaded pipe

Item #	Fuel Capacity (gal.)	Wt. (lbs.)	Dimensions (HxWxL in.)
KN350-3-01	50	131	22x30x32¼
KN352-3-01	75	164	26X30X43¼
KN354-3-01	90	185	26X30X52
KN360-3-01	110	219	27X37X56

WEATHER GUARD® TRUCK & VAN EQUIPMENT

High-Side Box

Aluminum

WEATHER GUARD® Truck Equipment

- Aluminum diamond plate with ARMOR TUF®
- Stainless-steel D-handle
- Adjustable leg mounting
- Three-point latching system
- Picture-frame body design



Item #	Height (in.)	Width (in.)	Length (in.)	Cubic ft.	Weight (lbs.)
KN396-0-01	16	13¼	96¼	11.8	80
KN372-0-01	16	13¼	72¼	8.9	64

*** Also available in black aluminum Diamond Plate and white and black steel finish**



WEATHER GUARD® TRUCK & VAN EQUIPMENT

Lo-Side Box

Steel

WEATHER GUARD® Truck Equipment



- Use: Separately or in combination with cross or saddle boxes
- J-hook mounting

Item #	Height (in.)	Width (in.)	Length (in.)	Cubic ft.	Ship Weight (lbs.)	Finish*
KN175-3-01	12 $\frac{7}{8}$	13 $\frac{5}{8}$	30 $\frac{3}{8}$	4.43	81	White
KN185-3-01	13	13 $\frac{1}{2}$	46 $\frac{1}{4}$	3.2	63	White

* Also available in Chrome and Black Diamond Plate Aluminum finish



KNAACK® JOBSITE STORAGE EQUIPMENT

Manual Transfer Pump

WEATHER GUARD® Truck Equipment

- Weight: 19 lbs.
- Includes: Pump, 8-ft. hose and nozzle
- UL tested and FM approved
- 15 gallons/100 strokes transfer capacity

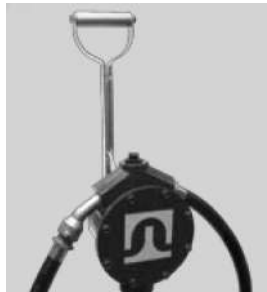

Item #

KN356



TUTHILL

Piston Hand Pump

Fill-Rite

- This compact, high flow, dual-action design delivers up to 20 GPM (76 LPM) per 100 strokes
- Lightweight and portable, with a variety of options, these pumps meet a full range of applications
- Ideal for gasoline, oil or a wide variety of approved liquids
- Lightweight cast aluminum body
- Stainless steel inner liner
- "Easy mount" 2" tank adapter
- Corrosion-Proof adjustable suction pipe
- Pump flow can be reversed by rotating piston 180°
- Steel yoke handle
- All models UL listed
- Anti-siphoning device
- Pump may be padlocked



Options:

- Series 800C flow meter
- Gooseneck spout and pail hook
- 8' hose and nozzle

Item #	Desc.
--------	-------

TUFR152	Basic UL Listed pump with vacuum breaker, bung adapter, 1" inlet & 3/4" outlet, 8' hose & nozzle and telescoping suction pipe. A kit is available to fit a 807C meter to this model. See kit number 807CMK
---------	--



TUTHILL
**Series 1200C DC
Pump
Fill-Rite**



- This industry standard DC pump dispenses up to 15 GPM (57 LPM)
 - The pump weighs less than 27 lbs., with hose and nozzle, and has a draw that's easy on the DC power source
 - Explosion-proof UL/cUL listed 1/4 HP motor with permanent magnet and ball bearings
 - Heavy-duty switch, thermal overload protection and junction box
 - Heavy-duty battery cable
 - Iron rotor
 - Automatic bypass valve
 - Built-in strainer
 - 12' (3.7m) hose with static ground wire
 - Manual nozzle with nozzle boot that protects against dirt and contamination
 - 2" threaded base for tank openings
 - Corrosion-Proof adjustable section pipe
 - Machined carbon vanes
 - Pump may be padlocked
 - No foot valve required
 - Rain proof
- Options:

- Series 800C meter in gallons/liters
- Automatic nozzle
- Series 2400C, 1/4 HP, 24 Volt DC 10 Amp motor

Item #	Desc.
TUFR1210C	Basic 12 volt DC pump with 18' of battery cable, hose & nozzle and telescoping suction pipe

TUTHILL
**Series 4200 DC Fuel
Pump
Fill-Rite**



- 12 Volt High-Flow Pump
- In a world where time is money, the FR4210 saves you both
- Thanks to its high flow rate of 20 GPM (76 LPM) and low 22 Amp draw, you'll spend less time at the pump and more time accomplishing the task at hand
- 1/4 HP, 12 Volt DC motor
- Built-in check valve, bypass valve and thermal expansion valve
- 1" diameter, 12' hose and 1" manual nozzle
- Pump may be padlocked
- Corrosion-Proof adjustable section pipe
- Explosion-proof permanent magnet motor
- Thermal overload protection
- 30-minute duty cycle/not for continuous operation
- Ball bearing construction, no lubrication required
- Machined carbon vanes
- 2" threaded base for tank openings
- UL/cUL listed motor
- Rain proof

Options:

- Series 900 meter in gallons/liters
- Automatic nozzle
- Series FR4400, 1/4 HP, 24 Volt DC 13 Amp motor

Item #	Desc.
TU4210	Basic High-Flow 12 Volt DC Pump with 1" X 12' Hose & Nozzle, Telescoping Suction Tube and 18' of Battery Cable



WEATHER GUARD® TRUCK & VAN EQUIPMENT

Steel Ladder Rack

WEATHER GUARD® Truck Equipment

- Load capacity rating is 1000 lbs. Capacity is increased to 1500 lbs. when using the Accessory Screen
- Includes 4 legs, 3 cross members and 2 side rails
- Ford Super Cab Super Duty, GM, Dodge and Ford F-150 extended cab require separate purchase of Model 1247 Airfoil
- Adjustable leg socket allows easy positioning of the leg for proper fit to truck bed
- Removable pin on rear cross member allows you to quickly take off the rear cross member for loading large materials
- Tie down bracket can be bolted wherever you wish



Item #	Type of Vehicle	Length (in.)	Ship Weight (lbs.)
KN1245	Full Size Pickup-Short Bed	133½	159
KN1275	Full Size Pickup-Long Bed	149½	171



WEATHER GUARD® TRUCK & VAN EQUIPMENT

Standard Underbed Box

WEATHER GUARD® Truck Equipment



- Large open stainless steel D handle is easy to grab and operate
- Versatile 180° drop down door
- Three point latching system creates a positive closure on three sides of the door, making it secure and water resistant

Item #	Dimensions (HxWxL in.)	Weight (lbs.)	Cubic ft.	Door Opening H x W (in.)	Finish*
KN530-3-01	18 $\frac{1}{8}$ x18 $\frac{1}{4}$ x30 $\frac{1}{8}$	70	5.6	14 $\frac{1}{2}$ x28 $\frac{1}{2}$	White Steel
KN536-3-01	18 $\frac{1}{8}$ x18 $\frac{1}{4}$ x36 $\frac{5}{8}$	82	6.7	14 $\frac{1}{2}$ x34 $\frac{3}{4}$	White Steel

* Also available in black steel finish

WEATHER GUARD® TRUCK & VAN EQUIPMENT

Aluminum Underbed Boxes

WEATHER GUARD® Truck Equipment



- Box and door are made of heavy .100 thick diamond-plate aluminum
- Aluminum door features a welded-on reinforcing channel to make the door more rigid and assure a weather-tight seal
- Brushed stainless steel paddle handle for extra life and durability
- Recessed door to allow for full swing-down position with cables disconnected
- ARMOR TUF® powder coating

Item #	Dimensions (HxWxL in.)	Weight (lbs.)	Cubic ft.	Door Opening H x W (in.)	Finish*
KN631	18x18x30 $\frac{1}{8}$	42	5.4	13 $\frac{1}{2}$ x25 $\frac{1}{4}$	Aluminum Diamond Plate
KN636	18x18x36 $\frac{5}{8}$	47	6.5	13 $\frac{1}{2}$ x31 $\frac{3}{4}$	Aluminum Diamond Plate

* Also available in black aluminum diamond plate

WEATHER GUARD® TRUCK & VAN EQUIPMENT

Drawer Units

PACK RAT®



- Mounts in most commercial vehicles
- Low-profile provides concealed and secure storage for heavy items without greatly reducing truck bed area

Item #	Finish*	Height (in.)	Width (in.)	Length (in.)	No. of Compartments Wide	Number of Dividers	Drawer Compartment WxLxD (in.)	Ship Weight (lbs.)
KN301-3	White	12 $\frac{3}{8}$	29 $\frac{7}{8}$	24	3	12	9.75 x 21 x 8.5	169
KN303-3	White	12 $\frac{3}{8}$	39 $\frac{5}{8}$	24	4	12	9.75 x 21 x 8.5	217
KN306-3	White	8 $\frac{7}{8}$	20	48	2	12	9.75 x 45 x 5	179
KN307-3	White	8 $\frac{7}{8}$	29 $\frac{7}{8}$	48	3	18	9.75 x 45 x 5	247
KN308-3	White	8 $\frac{7}{8}$	39 $\frac{5}{8}$	48	4	24	9.75 x 45 x 5	322
KN312-3	White	8 $\frac{7}{8}$	29 $\frac{7}{8}$	24	3	12	9.75 x 21 x 5	151
KN336-3	White	12 $\frac{3}{8}$	20	48	2	12	9.75 x 45 x 8.5	210
KN337-3	White	12 $\frac{3}{8}$	29 $\frac{7}{8}$	48	3	18	9.75 x 45 x 8.5	294
KN338-3	White	12 $\frac{3}{8}$	39 $\frac{5}{8}$	48	4	24	9.75 x 45 x 8.5	383

* KN308-3 and KN338-3 also available in black finish



WEATHER GUARD® TRUCK & VAN EQUIPMENT

All Purpose Van Racks

WEATHER GUARD® Van Solutions

- Powder Coated heavy duty steel rack for full-size vans
- Additional cross members can be added for longer materials and ladders
- Available finishes include durable bright white, black or clear coat
- Velcro straps assist in securing your ladder for transport



Item #	Number of Cross Members	Height (in.)	Width (in.)	Length (in.)	Ship Weight (lbs.)
KN205-3	2	16	8	70½	42
KN216-3	3	16	8	70½	63

WEATHER GUARD® TRUCK & VAN EQUIPMENT

WEEKENDER® Ladder Rack

WEATHER GUARD® Truck Equipment

- Easy on, easy off for that occasional need to carry a ladder or long material
- Adjustable, tubular steel pockets bolt into the side of the truck bed. A set screw holds the upright in place
- Load bar is adjustable to accommodate the varied widths of ladders
- Mounting bracket allows WEEKENDER® Ladder Rack to be installed on driver side or curb side of truck
- For '95 and newer pickups, Chevy, Dodge, Ford and Toyota Tundra



Item #	Ship Weight (lbs.)
KN1450	56

WEATHER GUARD® TRUCK & VAN EQUIPMENT

Interior Sliding Ladder Rack

WEATHER GUARD® Van Solutions

Includes:

- Complete Rail Assembly and Installation Hardware

Specifications:

- Universal mounting bracket- Adjusts to different vehicles
- Adjustable rail length- Accepts up to an 8 foot ladder
- Side mounting brackets- Stores ladders vertically
- Front cradle- Adjusts to different ladder types
- Adjustable Front and Rear Cradle Assemblies

Features:

- Keeps ladder off the floor and out of the elements
- System allows for ladders to be loaded or unloaded in just seconds
- Ladders are held in place by utilizing a unique tension-locking system; there is no need for buckles, latches or strap

Item #	Ship Weight (lbs.)
KN250	27



DELTA CONSOLIDATED INDUSTRIES

Vehicle Ladder Racks

PRO III™

- Optional 4th crossbar bolts on side channels where needed to support long, heavy loads
- Optional "no drill" clamp-on mounts eliminate drilling holes to mount the rack



Item #	Desc.
--------	-------

Ladder Racks

DBL80000 Full Size Fully Adjustable Ladder Rack

DELTA CONSOLIDATED INDUSTRIES

Van Rack

White

- High-strength adjustable height brackets clamp on the rain gutters to support up to 500-pound loads
- Use holes in brackets to secure the load on the rack



Item #	# of Bars
DBV30023	3
DBV30003	2



TRACRAC, INC.

TracRac Truck Rack System

Powder-Coated Aluminum

- Reposition or remove racks in seconds
- Rugged Aluminum - No rust or corrosion
- Carries 1,000 lbs. capacity



Item #	Desc.
TC21010	Base Rail Long Bed
TC21501	Short bed base rails
TC22500	Overhead Rack
TC22510	Overhead Rack - Ford Super Duty
TC22666	Cantilever Extensions
TC23000	Full Size Cargo Holder

RACK-STRAP

RACK STRAP Strap Mounting Brackets

- Solid steel constructed frame
- Zinc and yellow chromate plated for extreme weather protection
- 7 feet x 1.5 inch polyester strap w/ hook
- Complete assembly, ready to install

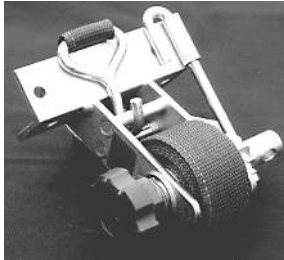

Item #	Desc.
RKRS-1	For Square Tube And Angle Iron
RKRS-3	Curved For 2" O.D. Pipe
RKSRS-4	Curved For 1 5/8" O.D. Pipe



EAGLE MANUFACTURING CO.

Safety Cans

Metal Type I

- Meets OSHA requirements and are UL and FM approved
- Made of galvanized steel
- Equipped with brass pour spout and flame arrestor



Item #	Cap.	Approval
EAUI-10-S	1 gal.	UL, ULC, FM
EAUI-20-S	2 gal.	UL, ULC, FM

Diesel

EAUI-20-SY	2 gal.	UL, ULC, FM
EAUI-50-SY	5 gal.	UL, ULC, FM

EAGLE MANUFACTURING CO.

30 Gallon Safety Storage Cabinets

Two-Door

- Meet OSHA requirements, are FM approved & meet NFPA Code 30 requirements
- 30 gallon capacity
- 43 in. wide x 18 in. deep x 44 in. high
- 14-3/4 in shelf depth, 1 shelf



Item #
EA1932

EAGLE MANUFACTURING CO.

Safety Cans Metal Type II



- These Eagle safety products meet OSHA requirements and most are either Factory Mutual Approved or listed by Underwriters Laboratories, Inc., (UL) and Underwriters Laboratories of Canada (ULC)
- Eagle Safety Containers are manufactured to exacting standards, reflecting sophisticated technology and superior workmanship
- Eagle equals engineering excellence, providing you with the most dependable containers on the market
- Eagle Type I Safety Cans for safer carrying and storing of gasoline and flammable liquids
- Equipped with brass pour spout and flame arrestor
- About Flame Arrestors - Eagle Safety Cans have double-walled brass flame arrestors
- Hot air entering the can is cooled as it passes through the arrestor
- The arrestors absorb and dissipate the heat, keeping the vapor temperature below its ignition (flash) point - another reason for using Eagle Safety Cans for temporary storage of gasoline or other flammable liquids

Item #	Cap.	Approval	Dia. (in.)	Ht. (in.)	Wt. (lbs.)
EAU2-26-S	2 gal.	UL, ULC, FM	11.25	9.50	8
EAU2-51-S	5 gal.	UL, ULC, FM	12.25	13.50	10

Diesel

EAU2-51-SY	5 gal.	UL, ULC, FM	12.50	13.50	10
------------	--------	-------------	-------	-------	----

Accessories

EAFD-25	12" Flex Spout 7/8" O.D.	-
EAF-15	10" Poly Funnel	-

EAGLE MANUFACTURING CO.

45 Gallon Safety Storage Cabinets

- Meet OSHA requirements, are FM approved & meet NFPA Code 30 requirements
- 45 gallon capacity
- 43 in. wide x 18 in. deep x 65 in. high
- 14-3/4 in. shelf depth, 2 shelves



Item #
EA1947

EAGLE MANUFACTURING CO.

Safety Storage Cabinets

- Meet OSHA requirements, are FM approved & meet NFPA Code 30 requirements



Item #	Desc	Max. Cap. (gal.)	Wdth. (in.)	Dpth. (in.)	Ht. (in.)	Shelf Dpth. (in.)	Shelves
EA1925	1 Door	12	23	18	35	14 3/4	1
EA1962	2 Doors	60	31 1/4	65	28	2	

Cabinet Accessories

EA1915	15, 30 & 45 gal. cabinet shelf	-
--------	--------------------------------	---

APEX

APEX
**1/4", 3/8" & 1/2" Drive
Socket Set**

**107-Piece Fractional/ Metric
Armstrong®**

- Made in the USA



Sockets

- 1/4 drive 6 pt. standard length: 5/32, 3/16, 7/32, 1/4, 9/32, 5/16, 11/32, 3/8, 7/16, 1/2
- 1/4 drive 6 pt. deep: 3/16, 7/32, 1/4, 5/16, 11/32, 3/8, 7/16
- 3/8 drive 12 pt. standard length: 3/8, 7/16, 1/2, 9/16, 5/8, 11/16, 3/4, 13/16
- 3/8 drive 12 pt. deep: 3/8, 7/16, 1/2, 9/16, 5/8, 11/16, 3/4, 13/16, 7/8
- 3/8 drive 6 pt. spark plug sockets: 5/8, 13/16
- 1/2 drive 12 pt. standard length: 1/2, 9/16, 5/8, 11/16, 3/4, 13/16, 7/8, 15/16
- 1/2 drive 12 pt. deep: 1/2, 9/16, 5/8, 11/16
- 1/4 drive 6 pt. standard length: 4mm, 5mm, 6mm, 7mm, 8mm, 9mm, 10mm, 11mm, 12mm, 13mm
- 1/4 drive 6 pt. deep: 4mm, 5mm, 6mm, 7mm, 8mm, 9mm, 10mm, 11mm
- 3/8 drive 12 pt. standard length: 10mm, 11mm, 12mm, 13mm, 14mm, 15mm, 16mm, 17mm, 18mm, 19mm
- 3/8 drive 12 pt. deep: 10mm, 11mm, 12mm, 13mm, 14mm, 15mm, 16mm, 17mm, 18mm, 19mm
- 1/2 drive 12 pt. standard length: 18mm, 19mm, 20mm, 21mm, 22mm

Drive Tools

- 1/4 drive 3" extension
- 1/4 drive round head ratchet
- 1/4 drive spinner handle
- 3/8 drive 3" extension
- 3/8 drive round head ratchet
- 3/8 F, 1/2 M adapter
- 1/2 drive 2" extension
- 1/2 drive round head ratchet

Item #
AR15-524A

APEX

1/4" Drive Socket Set

**13-Piece, 6 Point, Standard Length
Armstrong®**

Contents: 9 Sockets, 4 Drive Tools. Metal Box

- Sockets: 3/16, 7/32, 1/4, 9/32, 5/16, 11/32, 3/8, 7/16, 1/2
- Drive Tools: Extension, 1/4 Dr, 1-1/2"; 1/4" Dr, 6"; Spinner Handle, 1/4" Dr; Quick Release Ratchet, 1/4" Dr



Item #
AR15-246A

APEX

1/4" Drive Socket Set

**21-Piece, 6 Point
Armstrong®**

Contents: 16 Sockets, 5 Drive Tools. Metal Box

- Standard Length Sockets: 1/4, 9/32, 5/16, 11/32, 3/8, 7/16, 1/2
- Deep Sockets: 3/16, 7/32, 1/4, 9/32, 5/16, 11/32, 3/8, 7/16, 1/2
- Drive Tools: Extension, 1/4" Dr, 1-1/2"; Extension, 1/4" Dr, 6"; Universal Joint, 1/4" Dr; Spinner Handle, 1/4" Dr; Quick Release Ratchet, 1/4" Dr



Item #
AR15-248A

APEX

1/4" Drive Socket Set

**22-Piece 6 & 12 Point Standard and Deep
GEARWRENCH®**

- 6 Pt. Deep Sockets: 3/16, 7/32, 1/4, 9/32, 5/16, 11/32, 3/8, 7/16, 1/2
- 12 Pt. Standard Sockets: 3/16, 7/32, 1/4, 9/32, 5/16, 11/32, 3/8, 7/16, 1/2
- Drive Tools: 1/4 Drive Full Polish Teardrop Ratchet, 2" Standard Extension, 6" Standard Extension, Spinner Handle



Item #
GW80325

**Call Edge for help with finding the right tool for your job.
We stock and can source many more products than are
shown in this catalog.**

APEX

APEX
3/8" Drive Deep Impact Socket Set



9-Piece Fractional Armstrong®

- Includes Socket Bar 16-831 and (9) Socket Clips 16-843
- Sockets: 1/4, 5/16, 3/8, 7/16, 1/2, 9/16, 5/8, 11/16, 3/4

Item #
AR19-895

APEX
3/8" Drive Socket Set



12-Piece, 12 Point Armstrong®

Contents: 9 Sockets, 3 Drive Tools, Metal Box

- Standard Length Sockets: 3/8, 7/16, 1/2, 9/16, 5/8, 11/16, 3/4, 13/16
- 12-pt. Spark Plug Socket: 5/8
- Drive Tools: Extension, 3/8 Dr, 3"; Extension, 3/8 Dr, 6"; Quick Release Ratchet, 3/8 Dr

Item #
AR15-321A

APEX
3/8" Quick Release Ratchet



18-Piece, 12 Point Armstrong®

Contents: 15 Sockets, 3 Drive tools, Metal Box

- Standard Length Sockets: 3/8, 7/16, 1/2, 9/16, 5/8, 11/16, 3/4, 3/8, 7/16, 1/2, 9/16
- Deep Sockets: 5/8, 11/16, 3/4
- Spark Plug Socket: 5/8
- Drive Tools: Extension, 3"; Extension 6"; Ratchet, quick release

Item #
AR15-322A

APEX
3/8" Drive Socket Set

22-Piece Metric, 6 Point Armstrong®



Contents: 19 Sockets, 3 Drive Tools. In Case

- Standard Length Sockets: 10mm, 11mm, 12mm, 13mm, 14mm, 15mm, 16mm, 17mm, 18mm, 19mm
- Deep Sockets: 10mm, 11mm, 12mm, 13mm, 14mm, 15mm, 16mm, 17mm, 18mm, 19mm
- Drive Tools: Extension, 3"; Extension, 6"; Quick Release Ratchet

Item #
AR44-326A

APEX
3/8" Drive Socket Set

12-Pc. Fractional GEARWRENCH®



- 6 Pt. Std. Socket: 3/8", 7/16", 1/2", 9/16", 5/8", 11/16", 3/4", 7/8"
- 12 Pt. Std. Socket: 13/16"
- Drive tools: Ratchet, 3" Extension, 6" Extension

Item #
GW80556

APEX
3/8" Drive Socket Set

21-Pc. Fractional 6 & 12 Pt. Standard and Deep GEARWRENCH®



- 6 Pt. Deep Socket: 1/4", 3/8", 7/16", 1/2", 9/16", 5/8", 11/16", 3/4", 7/8"
- 12 Pt. Std. Socket: 1/4", 5/16", 3/8", 7/16", 1/2", 9/16", 5/8", 11/16", 3/4"
- Drive tools: Ratchet, 3" Extension, 6" Extension

Item #
GW80557

APEX
3/8" Drive Hex Driver Socket Set



7-Piece Armstrong®

Contents: 7 Hex Drivers. Includes Socket Bar (10) Socket Clips

- Hex Driver Sockets With Standard Length Bits: 1/8, 5/32, 3/16, 7/32, 1/4, 5/16, 3/8

Item #
AR15-440



APEX
1/2" Drive Sq. Drive Socket Set
12-Piece, 12-Point, Standard Length
Armstrong®

Contents: 10 Sockets, 2 Drive Tools.
In Case.

- 12-pt. Standard Length Sockets: 7/16, 1/2, 9/16, 5/8, 11/16, 3/4, 13/16, 7/8, 15/16, 1
- Drive Tools: Extension, 1/2" Dr, 6"; Quick Release Ratchet, 1/2" Dr

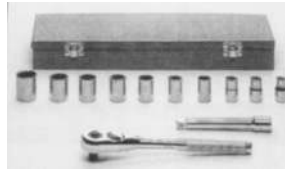

Item #
AR15-519A

APEX
1/2" Drive Socket Set
16-Piece, 12 Point, Standard Length
Armstrong®

Contents: 13 Sockets, 3 Drive Tools. In Case.

- Sockets: 7/16, 1/2, 9/16, 5/8, 11/16, 3/4, 13/16, 7/8, 15/16, 1, 1-1/16, 1-1/8, 1-1/4
- Drive Tools: Extension, 1/2" Dr, 6"; Flex Handle, 1/2" Dr, 15"; Quick Release Ratchet, 1/2" Dr

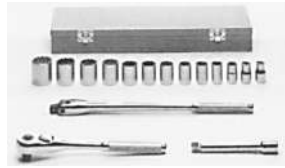

Item #
AR15-518A

APEX
1/2" Drive Socket Set
23-Piece
Armstrong®

Contents: 20 Sockets, 3 Drive Tools. In Metal Box.

- 6-pt. Standard Length Sockets: 7/16, 1/2, 9/16,
- 12-pt. Standard Length Sockets: 5/8, 11/16, 3/4, 13/16, 7/8, 15/16, 1, 1-1/16, 1-1/8, 1-1/4
- 12-pt. Deep Sockets: 1/2, 9/16, 5/8, 11/16, 3/4, 13/16, 7/8
- Drive Tools: Extension, 1/2" Dr, 6"; Flex Handle, 1/2" Dr, 15"; Quick Release Ratchet, 1/2" Dr



Item #
AR15-517A

APEX
1/2" Drive Socket Set
23-Piece, Metric, 12-Point,
Standard Length
Armstrong®

Contents: 19 Sockets, 4 Drive Tools.
In Case.

- Sockets: 9mm, 10mm, 11mm, 12mm, 13mm, 14mm, 15mm, 16mm, 17mm, 18mm, 19mm, 20mm, 21mm, 22mm, 23mm, 24mm, 27mm, 30mm, 32mm
- Drive Tools: Extension, 1/2" DR, 6"; Extension, 1/2" Dr, 10"; Flex Handle, 1/2" Dr, 15"; Quick Release Ratchet, 1/2" Dr



Item #
AR44-516A

APEX
1/2" Drive Socket Set
23-Pc. Fractional, 6-Point,
Standard and Deep
GEARWRENCH®

- 6 Pt. Deep Socket: 1/2", 9/16", 5/8", 11/16", 3/4", 13/16", 7/8", 15/16"
- 6 Pt. Std. Socket: 7/16", 1/2", 9/16", 5/8", 11/16", 3/4", 13/16", 7/8", 15/16", 1", 1-1/16", 1-1/8"
- Drive Tools: Ratchet, 5" Extension, 15" Extension



Item #
GW80707

APEX
1/2" Drive Socket Set
33-Pc. Fractional, 6
Pt., Standard and
Deep
GEARWRENCH®

- Std. Socket: 7/16", 1/2", 9/16", 5/8", 11/16", 3/4", 13/16", 7/8", 15/16", 1", 1-1/16", 1-1/8", 1-1/4", 1-1/2"
- Deep Socket: 7/16", 1/2", 9/16", 5/8", 11/16", 3/4", 13/16", 7/8", 15/16", 1", 1-1/16", 1-1/8", 1-1/4", 1-1/2"
- Polish Teardrop Ratchet
- Drive Tools: 3" Extension, 5" Extension, Flex Handle, Universal Joint



Item #
GW80715

APEX
1/2" Drive Impact
Socket Set
9-Piece, 6-Point
Armstrong®

Includes Socket Bar and (10) Socket Clips.

- Sockets: 1/2, 9/16, 5/8, 11/16, 3/4, 13/16



Item #
AR20-889

APEX

APEX 1/2" Drive Impact Socket Set



**11-Piece, 6-Point
Armstrong®**

Includes Socket Bar and (20) Socket Clips.

- Sockets: 1/2, 9/16, 5/8, 11/16, 3/4, 13/16, 7/8, 15/16, 1, 1-1/16, 1-1/8

Item #
AR20-893

APEX 1/2" Drive Deep Impact Socket Set



**8-Piece, 6-Point
Armstrong®**

Includes Socket Bar and (8) Socket
Clips

- Sockets: 1/2, 9/16, 5/8, 11/16, 3/4, 13/16, 7/8, 15/16

Item #
AR20-897

APEX 1/2" Drive Impact Socket Set



**14-Piece, Deep
Armstrong®**

Includes Socket Bar with Clips.

- Sockets: 3/8, 7/16, 1/2, 9/16, 5/8, 11/16, 3/4, 13/16, 7/8, 15/16, 1, 1-1/16, 1-1/8, 1-1/4

Item #
AR20-895A

APEX 1/2" Drive Hex Bit Socket Set



**7-Piece
Armstrong®**

Contents: 7 Hex Drivers in cardboard box. Includes Socket Bar and (10) Socket Clips.

- Hex Driver Sockets with Standard Length Bits: 1/4, 5/16, 3/8, 7/16, 1/2, 9/16, 5/8

Item #
AR15-610

APEX 3/4" Drive Socket Set

**27-Piece Standard, 12-Point, Standard
GEARWRENCH®**

- SAE Socket: 7/8", 15/16", 1", 1-1/16", 1-1/8", 1-3/16", 1-1/4", 1-5/16", 1-3/8", 1-7/16", 1-1/2", 1-5/8", 1-11/16", 1-3/4", 1-13/16", 1-7/8", 2", 2-1/8", 2-3/16", 2-1/4", 2-3/8"
- Drive Tools: Ratchet, 5" Extension, 8" Extension, 16" Extension, 18" Sliding T Handle, 19" Flex Handle



Item #
GW80880

APEX 3/4" Drive 6-Pt. Impact Socket Set

**14-Piece
Armstrong®**

Includes (2) Socket Bars and (14)
Socket Clips

- Sockets: 3/4, 13/16, 7/8, 15/16, 1, 1-1/16, 1-1/8, 1-3/16, 1-1/4, 1-5/16, 1-3/8, 1-7/16, 1-1/2, 1-5/8

Item #
AR21-893

APEX 3/8" Drive 6-Point. Standard Length Sockets Armstrong®

Item #	Size (in.)
AR11-008	1/4
AR11-010	5/16
AR11-012	3/8
AR11-014	7/16
AR11-022	1 1/16
AR11-028	7/8
AR11-030	1 5/16
AR11-032	1





APEX
3/8" Drive Sockets
12-Point, Standard Length
Armstrong®



Item #	Size (in.)
AR11-110A	5/16
AR11-112A	3/8
AR11-114A	7/16
AR11-116A	1/2
AR11-118A	9/16
AR11-120A	5/8
AR11-122A	11/16
AR11-124A	3/4
AR11-126A	13/16
AR11-128A	7/8

APEX
3/8" Drive Sockets
6-Point, Deep
Armstrong®



Item #	Open. (in.)
AR11-212	3/8
AR11-214	7/16
AR11-220	5/8
AR11-222	11/16
AR11-224	3/4

APEX
3/8" Drive Sockets
12-Point, Deep
Armstrong®



Item #	Open. (in.)
AR11-312A	3/8
AR11-314A	7/16
AR11-316A	1/2
AR11-318A	9/16
AR11-320A	5/8
AR11-322A	11/16
AR11-324A	11/16
AR11-326A	13/16
AR11-328A	7/8

APEX
3/8" Drive Regular Spark Plug Sockets

6-Point
Armstrong®



Item #	Size (in.)
AR11-501	5/8
AR11-504	13/16

APEX
3/8" Drive Standard Length Hex Driver Sockets
Armstrong®



Item #	Bit Size (in.)
AR11-708	1/8
AR11-709	9/64
AR11-710	5/32
AR11-711	13/16
AR11-712	7/32
AR11-713	1/4
AR11-714	5/16
AR11-715	3/8

APEX
3/8" Quick Release Ratchet



Tear Drop
Armstrong®

Fed. Std. GGG-W-641e ANSI Spec. B107.10M

Item #	Length (in.)	No. of Teeth
AR11-967A	7.625	36

APEX
3/8" Flex Head Ratchet



Tear Drop, Quick Release
Armstrong®

Fed. Std. GGG-W-641e ANSI Spec. B107.10M

Item #	Length (in.)	No. of Teeth
AR11-974A	11.375	36

APEX

APEX 3/8" Drive Hinge Handle

Armstrong®



- Chamfered drive ends guide socket onto drive tangs
- Designed to give strength and balance
- High polish chrome finish
- Also available in black finish

Item #	Length (in.)
AR11-918	8½

APEX 3/8" Drive T-Handle

Armstrong®



- Chamfered drive guide sockets onto drive tangs
- High polish chrome finish
- 7" overall length

Item #	Length (in.)
AR11-938	8

APEX 3/8" Drive Speeder

Armstrong®



- Chamfered drive ends guide socket onto drive tangs
- High polish chrome finish
- 16-3/4" overall length

Item #	Length (in.)
AR11-935	16¾

APEX 3/8" Drive Extensions

Armstrong®



- Chamfered drive ends guide socket onto drive tangs
- Designed to give strength and balance
- High polish chrome finish

Item #	Wt. (lbs.)	OA Length (in.)
AR11-921	.08	1½
AR11-922A	.13	3
AR11-923A	.21	6
AR11-925A	.27	8
AR11-927	.40	12

APEX 3/8" Drive Ratchet Adapters

Armstrong®



- Chamfered drive ends guide sockets onto drive tangs
- Chamfered receiving ends guide drives onto drive tangs

Item #	Desc. (in.)	Wt. (lbs.)
AR11-951	¾ F, ¼ M	.06
AR11-952A	¾ F, ½ M	

APEX 3/8" Drive Universal Joint

Armstrong®



Item #	Length (in.)
AR11-947	2.000

APEX 1/2" Drive Sockets

Armstrong®



Item # Open. (in.)

AR12-014	7/16
AR12-016	½
AR12-018	9/16
AR12-020	5/8
AR12-022	11/16
AR12-026	13/16
AR12-028	7/8
AR12-032	1
AR12-034	1 1/16
AR12-040	1 ¼

APEX 1/2" Drive Spark Plug Socket

6-Point
Armstrong®



Item #	Size (in.)
AR12-504	13/16



APEX

APEX
1/2" Drive Sockets
12-Point, Standard Length
Armstrong®



Item #	Size (in.)
AR12-112A	3/8
AR12-114A	7/16
AR12-116A	1/2
AR12-118A	9/16
AR12-120A	5/8
AR12-122A	11/16
AR12-124A	3/4
AR12-126A	13/16
AR12-128A	7/8
AR12-130A	15/16
AR12-132A	1
AR12-134A	1 1/16
AR12-136A	1 1/8
AR12-140A	1 1/4
AR12-142	1 5/16
AR12-144	1 3/8
AR12-146	1 7/16
AR12-148A	1 1/2

APEX
1/2" Drive Sockets
12-Point, Deep Length
Armstrong®



Item #	Size (in.)
AR12-312A	3/8
AR12-316A	1/2
AR12-318A	9/16
AR12-320A	5/8
AR12-322A	11/16
AR12-324A	3/4
AR12-326A	13/16
AR12-328A	7/8
AR12-330A	15/16
AR12-332A	1
AR12-334A	1 1/16
AR12-336A	1 1/8
AR12-340A	1 1/4

APEX
1/2" Drive Sockets
6-Point, Deep Length
Armstrong®



Item #	Open. (in.)
AR12-212	3/8
AR12-216	1/2
AR12-220	5/8
AR12-226	13/16
AR12-244	1 3/8

APEX
1/2" Drive Standard Length Hex
Driver Sockets
Armstrong®



Item #	Bit Size (in.)
AR12-714	5/16
AR12-715	3/8
AR12-716	7/16
AR12-717	1/2
AR12-718	9/16
AR12-719	5/8

APEX
1/2" Sq. Drive Teardrop
Ratchet



Quick Release
Armstrong®

Fed. Std. GGG-W-641e ANSI Spec. B107.10M

Item #	Length (in.)
AR12-967A	10.313

APEX
1/2" Drive Ratchet
Armstrong®



- Comfort grip hand-fitting handle
- Recessed reversing lever
- On-Off indicating lever
- 10-1/2" overall length, 1.625" head width, .875" head depth

Item #
AR12-972

APEX

APEX
1/2" Drive Round Head Ratchet
Armstrong®



Item #	Length (in.)	Head Width (in.)	Head Depth (in.)
AR12-915	10.480	1.750	1.300

APEX
1/2" Round Head Ratchet



Quick Release Long Handle
Armstrong®

Item #
AR12-909A

APEX
1/2" Drive, Long Handle Teardrop Ratchet
Armstrong®



Item #	Length (in.)	Head Width (in.)	Head Depth (in.)
AR12-973	15	1.625	0.875

APEX
1/2" Drive, Flex Head Teardrop Ratchet
Armstrong®



Item #	Length (in.)	Head Width (in.)	Head Depth (in.)
AR12-974	14 1/4	1.625	0.875

APEX
1/2" Teardrop Flex Head Ratchet

Quick Release
Armstrong®



Item #
AR12-974A

APEX
1/2" Drive Flex Handle
Armstrong®



- Material: Forged alloy steel
- Finish: Nickel chrome
- Locking Type: Ball
- Meets Fed. Std GGG-W-641e
- Meets ANSI Spec. B107.10M

Item #	Length (in.)
AR12-917A	15.00

APEX
1/2" Drive Speeder Handle
Armstrong®



- Meets Federal Standards GGG-W-641e: Meets ANSI Spec.

Item #	Length (in.)
AR12-935A	19.56

APEX
1/2" Drive T-Handle
Armstrong®



- Chamfered drive end guides sockets onto drive tang
- High polished chrome finish

Item #	Length (in.)
AR12-938	15

APEX
1/2" Drive Extensions
Armstrong®



- Notched on all four sides of the square so the loading ball in the drive tang will seat on any wall
- Chamfered drive ends guide socket onto drive tang
- High polished chrome finish

Item #	OA Lgth. (in.)
AR12-921	2
AR12-923A	6
AR12-924A	10
AR12-927	20

APEX
1/2" Drive Adapters
Armstrong®



Item #	Desc. (in.)
AR12-951	1/2 F, 3/8 M
AR12-952	1/2 F, 3/4 M



APEX

APEX
1/2" Drive Universal Joint
Armstrong®

Fed. Std. GGG-W-641e ANSI Spec.
B107.10M

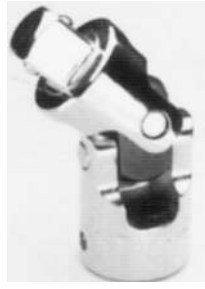

Item #	Length (in.)
AR12-947A	2.690

APEX
1/2" Drive Ratchet
Repair Kit
Armstrong®

Contains:

- Illustrated instruction sheet for repairing the 12-972, 12-973, or 20-972 ratchets
- Gear, Pawl, Shifting lever, Spring, Ball, Cover plate, Cover plate screws



Item #
AR12-990

APEX
1/2" Drive Impact Sockets
12-Point
Armstrong®

Item #	Open. (in.)
AR20-012	3/8
AR20-014	7/16
AR20-016	1/2
AR20-018	9/16
AR20-020	5/8
AR20-022	11/16
AR20-024	3/4
AR20-026	13/16
AR20-028	7/8
AR20-030	15/16
AR20-032	1
AR20-034	1 1/16
AR20-036	1 1/8
AR20-038	1 3/16
AR20-040	1 1/4
AR20-042	1 5/16
AR20-044	1 3/8
AR20-046	1 7/16
AR20-048	1 1/2



APEX
1/2" Drive Impact Sockets

12-Point, Deep
Armstrong®



Item #	Open. (in.)
AR20-212	3/8
AR20-214	7/16
AR20-216	1/2
AR20-218	9/16
AR20-220	5/8
AR20-222	1 1/16
AR20-224	3/4
AR20-226	13/16
AR20-228	7/8
AR20-230	15/16
AR20-232	1
AR20-234	1 5/16
AR20-236	1 1/8
AR20-240	1 1/4
AR20-242	1 5/16
AR20-244	1 3/8
AR20-246	1 7/16
AR20-248	1 1/2

APEX
1/2" Drive Universal Impact
Sockets

6-Point
Armstrong®

- True 360° rotation of socket end for extended range of motion
- Maximum operating angle 30°



Item #	Opening Size (in.)
AR20-574	3/4
AR20-580	15/16

APEX
1/2" Drive Impact
Extensions
Armstrong®



Item #	OA Lgth. (in.)
AR20-923	5
AR20-924	10

APEX

APEX 1/2" Drive Impact Drive Adapter Armstrong®

20-952: Male square has pin thru hole.

- ANSI B107.2
- Fed'l spec. GGG-W-660a



Item #	Desc. (in.)	Overall Length
AR20-952	1/2 F, 3/4 M	1.813 1/2 in. F, 3/4 in. M

APEX 1/2" Drive Impact Universal Joint Armstrong®

Item #
AR20-947



APEX 3/4" Drive Sockets 12-Pt. Standard Length Armstrong®

Item #	Open. (in.)
AR13-126	15/16
AR13-128	7/8
AR13-130	15/16
AR13-132	1
AR13-134	1 1/16
AR13-136	1 1/8
AR13-138	1 3/16
AR13-140	1 1/4
AR13-142	1 5/16
AR13-144	1 3/8
AR13-146	1 7/16
AR13-148	1 1/2
AR13-150	1 9/16
AR13-152	1 5/8
AR13-154	1 11/16
AR13-156	1 3/4
AR13-158	1 13/16
AR13-160	1 7/8
AR13-164	2
AR13-168	2 1/8
AR13-172	2 1/4



APEX 3/4" Drive Ratchets Armstrong®

Fed. Std. GGG-W-641e ANSI Spec. B107.10M

Item #
AR13-972

Repair Kit
AR13-990



APEX 3/4" Flex Handle Armstrong®

- Nickel-chrome finish that provides a lifetime of corrosion resistance for these heavy-duty tools

Item #	Length (in.)
AR13-918	17.550



APEX 3/4" Drive T-Handle Armstrong®

- Drive Size: 3/4" (male square)
- Locking Type: Ball
- Meets Federal Standards GGG-W-641e
- Meets ANSI Spec. B107.10M

Item #	Length (in.)
AN13-938	18



APEX 3/4" Drive Extensions Armstrong®

Fed. Std. GGG-W-641e ANSI Spec. B107.10M

Item #	Size (in.)
AR13-922	5
AR13-923	8
AR13-925	16



APEX 3/4" Drive Ratchet Adapters Armstrong®

- Chamfered drive ends guide sockets onto drive tangs
- Chamfered receiving ends guide drives onto drive tangs
- High polished chrome finish

Item #	Desc. (in.)	Wt. (lbs.)
AR13-951	3/4 F, 1/2 M	.51
AR13-952	3/4 F, 1 M	.75



APEX

APEX
3/4" Drive Impact Sockets
6-Point
Armstrong®



Item #	Open. (in.)
AR21-024	3/4
AR21-026	13/16
AR21-028	7/8
AR21-030	15/16
AR21-032	1
AR21-034	1 1/16
AR21-036	1 1/8
AR21-038	1 3/16
AR21-040	1 1/4
AR21-042	1 5/16
AR21-044	1 3/8
AR21-046	1 7/16
AR21-048	1 1/2
AR21-052	1 5/8
AR21-054	1 11/16
AR21-056	1 3/4
AR21-058	1 13/16
AR21-060	1 7/8
AR21-062	1 15/16
AR21-064	2

APEX
3/4" Drive Impact Sockets
6-Point, Deep
Armstrong®



Item #	Open. (in.)
AR21-224	3/4
AR21-226	13/16
AR21-228	7/8
AR21-230	15/16
AR21-232	1
AR21-234	1 1/16
AR21-236	1 1/8
AR21-238	1 3/16
AR21-240	1 1/4
AR21-242	1 5/16
AR21-244	1 3/8
AR21-246	1 7/16
AR21-248	1 1/2
AR21-252	1 5/8

APEX
3/4" Drive Impact Extensions
Armstrong®



Item #	OA Lgth. (in.)
AR21-923	7
AR21-924	10

APEX
3/4" Drive Impact Drive Adapters
Armstrong®



Item #	Desc. (in.)
AR21-951	3/4 F, 1/2 M
AR21-952	3/4 F, 1 M

APEX
3/4" Drive Impact Universal Joint
Armstrong®



Item #
AR21-947

APEX
3/4" Drive Ret Rings
Armstrong®



Item #	ID of Ring	Hub Dia. Skt. (lbs.)
AR21-964	1 7/16"	1 5/8"
AR21-965	1 5/8"	1 3/4"
AR21-967	1 3/4"	1 7/8"

APEX
1" Drive Adapter
Armstrong®

- High polished chrome finish

Item #	Desc. (in.)
AR14-951	1" F, 3/4" M



APEX

APEX
1" Drive Impact Drive Adapter
Armstrong®



Item #	Desc. (in.)
AR22-951	1 F, 3/4 M

APEX
1" Drive Ret Rings
Armstrong®



Item #	ID of Ring (in.)	Hub Dia. Skt. (lbs.)
AR22-965	2 1/8	2 1/4 and 2 3/8



CHAINRING CONSTRUCTION PRODUCTS
Dawson Channel Socket

Channel Socket

- A unique tool which fits standard 1/2" drive ratchets
- It enables you to attach slotted channel directly to walls, floors & ceilings without the use of brackets or fittings, allowing unobstructed access to the channel mouth for hangers
- Reduce construction time
- Improved quality of connections
- CSM10: Socket for 3/8" hardware
- CSM10e: Long socket for 3/8" hardware in 2-7/16" & 3-1/4" deep strut
- CSM10s: Shallow socket for 3/8" hardware in 13/16" deep strut
- CSM12: 1-5/8" deep strut for 1/2" hardware (3/4" bolt head)
- CSM12e: 2-7/16" & 3-1/4" deep strut for 1/2" hardware (3/4" bolt head)



Item #	Drive Size (in.)	Max Strut Depth (in.)
CNCSM10	3/8	1 5/8
CNCSM10e	3/8	3 1/4
CNCSM10s	3/8	1 3/16
CNCSM12	1/2	1 5/8
CNCSM12e	1/2	3 1/4

APEX
Ratcheting Wrench Set

7-Piece, 12-Point
Armstrong®

- Wrenches: 3/8, 7/16, 1/2, 9/16, 5/8, 11/16, 3/4
- Vinyl roll

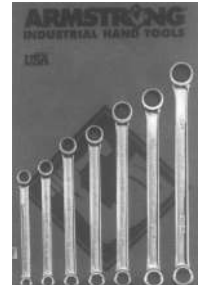

Item #
AR27-609

APEX
Ratcheting Combination Wrench Set

7-Piece, SAE
GEARWRENCH®

- Wrenches: 15/16", 3/8", 17/16", 1/2", 9/16", 5/8", 3/4"



Item #
GW9317

APEX
Ratcheting Combination Wrench Set

7-Piece, Flex Handle
GEARWRENCH®

- Flex Combination Ratcheting Wrench: 3/8", 7/16", 1/2", 9/16", 5/8", 11/16", 3/4"



Item #
GW9700

APEX
Ratcheting Combination Wrench Set

8-Pc., Reversible
GEARWRENCH®

- Reversible Combination Ratcheting Wrench: 5/16", 3/8", 7/16", 1/2", 9/16", 5/8", 11/16", 3/4"



Item #
GW9533



APEX

APEX
Ratcheting Wrench Set

17-Piece, 12-Point, Inches & Metric Armstrong®



- Wrenches: 3/8", 7/16", 1/2", 9/16", 5/8", 11/16", 3/4"
- Metric Wrenches: 10mm, 11mm, 12mm, 13mm, 14mm, 15mm, 16mm, 17mm, 18mm, 19mm

Item #
AR27-708

APEX
Midget Combination Wrench Set

10-Piece, 12- and 6-Point Armstrong®



- Available as a set only.
- Packaged in a pouch.
- Wrenches: 5/32 - 6 Pt. , 3/16 - 6 Pt. , 13/64 - 6 Pt. , 7/32 - 12 Pt. , 15/64 - 12 Pt. , 1/4 - 12 Pt. , 9/32 - 12 Pt. , 5/16 - 12 Pt. , 3/8 - 12 Pt. , 7/16 - 12 Pt.

Item #
AR25-600

APEX
Combination Wrench Set

9-Piece Armstrong®



- Wrenches: 1/4, 5/16, 3/8, 7/16, 1/2, 9/16, 5/8, 11/16, 3/4
- Vinyl roll

Item #
AR25-611

APEX
Combination Wrench Set

11-Piece Armstrong®



- Wrenches: 3/8, 7/16, 1/2, 9/16, 5/8, 11/16, 3/4, 13/16, 7/8, 15/16, 1
- Vinyl roll

Item #
AR25-608

APEX
Combination Wrench Set

11-Piece, Metric Armstrong®



- Wrenches: 7mm, 8mm, 9mm, 10mm, 11mm, 12mm, 13mm, 14mm, 15mm, 17mm, 19mm
- Vinyl Roll

Item #
AR52-606

APEX
Combination Wrench Set

14-Piece Armstrong®



- Wrenches: 3/8, 7/16, 1/2, 9/16, 5/8, 11/16, 3/4, 13/16, 7/8, 15/16, 1, 1-1/16, 1-1/8, 1-1/4
- Vinyl roll

Item #
AR25-607

APEX
Long Pattern Combination Wrench Set

15-Piece GEARWRENCH®



- Long Pattern Combination Wrench:
1/4", 9/32", 5/16", 11/32", 3/8", 7/16", 1/2", 9/16", 5/8", 11/16", 3/4", 13/16", 7/8", 15/16"

Item #
GW81918

APEX
Regular Length Combination Wrench

6-Point Armstrong®



Item #	Open. (in.)	OA Lgth. (in.)
AR25-004	1/8	3.000
AR25-005	5/32	3.000
AR25-006	3/16	3.188
AR25-007	7/32	3.375
AR25-009	9/32	3.800

APEX

APEX Combination Ratcheting Wrenches



SAE GEARWRENCH®

Item #	Size (in.)	Overall Length (in.)
GW9008	1/4	4.921
GW9010	5/16	5.508
GW9011	11/32	5.882
GW9012	3/8	6.256
GW9014	7/16	6.508
GW9016	1/2	7.008
GW9018	9/16	7.504
GW9020	5/8	8.201
GW9022	11/16	8.878
GW9024	3/4	9.764
GW9026	13/16	11.476
GW9028	7/8	11.476
GW9030	15/16	13.114
GW9032	1	13.114
GW9034	1 1/16	14.142
GW9036	1 1/8	15.846
GW9038	1 1/4	16.764
GW9060	1 5/16	18.110
GW9062	1 3/8	18.110
GW9040	1 7/16	19.685
GW9042	1 1/2	19.685
GW9044	1 9/16	22.638
GW9046	1 5/8	22.638
GW9048	1 11/16	24.213
GW9050	1 3/4	24.213
GW9052	1 13/16	25.394
GW9054	1 7/8	25.394
GW9056	2	25.787

APEX Combination Wrenches



12-Point Armstrong®

- Nickel-chrome finish provides lifetime corrosion resistance
- Drop forged and hardened alloy is stronger
- 15 degree offset handle offers better knuckle clearance
- Chamfered opening allows for faster and easier fit over fastener

Item #	Size (in.)	Overall Length
--------	------------	----------------

Regular Length

AR30-308	1/4	3.99
AR30-310	5/16	4.38
AR30-312	3/8	5.32
AR30-314	7/16	5.88
AR30-316	1/2	6.54
AR30-318	9/16	7.13
AR30-320	5/8	8.00
AR30-322	11/16	8.81
AR30-324	3/4	9.67
AR30-326	13/16	10.58
AR30-328	7/8	11.56
AR30-330	15/16	12.58
AR30-332	1	13.56

Long Length

AR25-484	1 1/16	14.69
AR25-486	1 1/8	15.63
AR25-490	1 1/4	16.94
AR25-242	1 5/16	18.31
AR25-244	1 3/8	20.35
AR25-246	1 7/16	20.35
AR25-248	1 1/2	20.35
AR25-252	1 5/8	24.08
AR25-254	1 11/16	24.08
AR25-256	1 3/4	26.09
AR25-258	1 13/16	26.09
AR25-260	1 7/8	27.10
AR25-264	2	29.10
AR25-268	2 1/8	28.75
AR25-272	2 1/4	28.75
AR25-276	2 3/8	28.75
AR25-280	2 1/2	28.75



APEX

APEX
**Short Combination
Wrenches**
12-Point
Armstrong®



- Full polish finish

Item #	Open. (in.)	OA Lgth. (in.)
AR25-111	1 ¹ / ₃₂	4.000
AR25-112	3 ¹ / ₁₆	4.250
AR25-114	7 ¹ / ₁₆	5.062
AR25-119	1 ¹ / ₃₂	6.312
AR25-120	5 ¹ / ₁₆	6.312
AR25-125	25 ¹ / ₃₂	7.375
AR25-126	1 ¹ / ₁₆	7.500
AR25-128	7 ¹ / ₁₆	7.875

APEX
**Long Combination
Wrenches**
12-Point
Armstrong®



- Full polish finish

Item #	Open. (in.)	OA Lgth. (in.)
AR25-210	5 ¹ / ₁₆	5.750
AR25-211	1 ¹ / ₃₂	5.750
AR25-212	3 ¹ / ₁₆	6.500
AR25-214	7 ¹ / ₁₆	7.250
AR25-216	1 ¹ / ₂	8.000
AR25-218	9 ¹ / ₁₆	8.750
AR25-220	5 ¹ / ₈	9.500
AR25-222	1 ¹ / ₁₆	10.250
AR25-226	13 ¹ / ₁₆	11.750
AR25-228	7 ¹ / ₈	12.500
AR25-232	1	14.000
AR25-234	1 ¹ / ₁₆	14.750
AR25-242	15 ¹ / ₁₆	20.125

APEX
**Black Finish
Construction Wrench**
Armstrong®



Item #	Open. (in.)	OA Lgth. (in.)	Lgth. Tang (in.)
AR32-824	3 ¹ / ₄	12.000	6.750

APEX

**Micrometer Torque
Wrenches**
Armstrong®



- 10° ratcheting angle permits use in confined areas
- Rubber seal keeps lubrication in accuracy of +/- 3% and repeatability
- Easy to read dual scales - primary in SAE and secondary in metric
- Detent-style locking collar prevents accidental changes of settings
- Lightly knurled and grooved handle provides comfortable, non-slip grip

Item #	Primary Scale Range (ft/lbs.)	Primary Scale Incr. (in./lbs.)	Alternate Scale Range (Nm)	Alternate Scale Incr. (Nm)
--------	-------------------------------	--------------------------------	----------------------------	----------------------------

3/8" Drive

AR64-041	50-250	1	6-29	.11
AR64-046	10-100	.5	17-139	.7

1/2" Drive

AR64-086	25-250	1	43-348	1.4
----------	--------	---	--------	-----

APEX

Punch and Chisel Set
5-Piece
Gearwrench®



Contains:

- 82270 - 3/8" x 5" Center Punch
- 82273 - 1/8" x 5" x 5/16" Pin Punch
- 82274 - 5/32" x 5-1/4" x 5/16" Pin Punch
- 82275 - 3/16" x 5-1/2" x 5/16" Pin Punch
- 82264 - 1/2" x 6" x 3/8" Cold Chisel

Item #
GW82304

APEX

Punch and Chisel Set
12-Piece
Gearwrench®



Contains:

- 82261 - 1/4" x 4-3/4" x 1/4" Cold Chisel, 82262 - 3/8" x 5" x 5/16" Cold Chisel, 82264 - 1/2" x 6" x 3/8" Cold Chisel, 82265 - 5/8" x 6-1/2" x 3/8" Cold Chisel, 82270 - 3/8" x 5" Center Punch, 82272 - 3/32" x 4-3/4" x 5/16" Pin Punch, 82273 - 1/8" x 5" x 5/16" Pin Punch, 82274 - 5/32" x 5-1/4" x 5/16" Pin Punch, 82275 - 3/16" x 5-1/2" x 5/16" Pin Punch, 82278 - 1/8" x 8" x 3/8" Long Taper Punch, 82283 - 3/16" x 5" x 3/8" Starter Punch, 82285 - 1/8" x 4-1/2" x 5/16" Starter

Item #
GW82305

APEX

APEX Pin Punch Armstrong®



- Stock Shape: Hex
- Material: Steel
- Type: Pin Punch

Item #	Point (in.)	Hex Size (in.)	Length (in.)
AR70-105	1/8	5/16	5
AR70-131	1/4	3/8	7

APEX Center Punch Armstrong®



Item #	Hex Size (in.)	Length (in.)
AR70-239	1/2	6

APEX Cold Chisels Armstrong®



Item #	Cut (in.)	Hex Size (in.)	OA Length (in.)
AR70-309	1/2	3/8	6
AR70-311	5/8	1/2	6 1/2
AR70-313	3/4	5/8	7

APEX Aligning Pry Bar Armstrong®



- Heat treated alloy steel

Item #	Stock Size (in.)	OA Lgth. (in.)
AR70-507	7/8	30

APEX Magnetic Retrieving Tool Armstrong®



- Designed to position or retrieve small objects
- Spring-loaded plunger opens jaw at end of flexible casing
- When plunger is released, jaws grip object with surprising strength

Item #	Length (in.)
AR70-933	16 3/4 - 26 3/4

APEX Inspection Mirrors Armstrong®



- Designed for all types of inspection work where direct sight lines are obstructed
- Features an all-angle ball joint for greater versatility

Item #	Shape	Size (in.)	Length (in.)
AR70-927	Circular	1 1/4	8
AR70-929	Rectangular	2 1/8 x 3 1/2	11 1/4 to 15 1/2

APEX Screw Extractor Set Armstrong®



- 5-piece set in vinyl roll
- Contains:
- 70-950
- 70-952
- 70-954
- 70-956
- 70-958

Item #
AR70-970

APEX Screw Extractors Armstrong®



- Alloy steel, black finish
- Straight, tapered flutes
- Extractors do not bind in the screw or cause it to spread against the hole
- Used for right or left handed screws, bolts or studs

Item #	Screw Size	Pipe Sizes (in.)	Lgth. (in.)	Use Drill Size (in.)	Min. Hole Dpth. (in.)	Shank (in.)	Size of Small End (in.)
AR70-952	5/16 to 3/8	-	2 5/8	3/16	1/2	3/16	1 1/64
AR70-954	7/16 to 1/2	1/8	2 7/8	1 5/64	1/2	1/4	1 3/64
AR70-958	9/16 to 5/8	3/8	3 1/4	3/8	5/8	3/8	1 1/32

APEX

APEX C-Clamps

Deep Throat Pattern Armstrong®



- Frame is drop forged carbon steel; all other parts are machined from carbon steel

Item #	Max Cap. (in.)	Min Cap. (in.)	Depth of Throat from Center of Screw (in.)	Thread Size	Length of Screws (in.)	Min. Proof Test
AR78-402	2	0	2	1/2"-8	4 3/4	3,300
AR78-403	3	0	2 3/8	1/2"-8	5 3/4	3,500
AR78-404	4	0	3 1/4	3/4"-6	7 5/8	4,100
AR78-406	6	0	3 5/8	3/4"-6	9 7/8	5,400
AR78-408	8	0	4 1/2	3/4"-6	12 3/8	5,900
AR78-410	10	3	5 3/8	3/4"-6	12 3/8	6,200
AR78-412	12	4	5 3/4	7/8"-6	13 1/2	9,300

CHANNELLOCK

CHANNELLOCK

Concrete Nippers

- High carbon steel for superior performance
- Laser heat-treated cutting edges last longer
- Knife end anvil cutting edge
- Channellock blue comfort grips



Item #	Length (in.)
CL35-250	10
CL35-300	12

CHANNELLOCK

Diagonal Cutting Pliers

- Perfectly mated cutter, heat treated to hold it's edge
- Polished high carbon drop forged steel
- Channellock blue comfort grips



Item #	Length (in.)	Desc.
CL337	7	Lap Joint
CL435	5	Box Joint

CHANNELLOCK

Tongue & Groove Pliers



- Right angle teeth grip in all directions
- Safe-T-Stop™ prevents finger pinch
- Double Tongue and Groove, won't slip
- Channellock blue comfort grips

Item #	Adj.	Lgth. (in.)	Cap. (in.)	Jaw
CL410	4	9 1/2	1 1/8	Straight
CL420	5	9 1/2	1 1/2	Straight
CL422	5	9 1/2	1 1/2	Curved
CL426	5	6 1/2	7/8	Straight
CL430	7	10	2	Straight
CL432	7	10	2	Curved
CL440	7	12	2 1/4	Straight
CL442	7	12	2 1/4	Curved
CL460	8	16	4 1/4	Straight
CL480	12	20 1/4	5 1/2	Straight



CHANNELLOCK
Slip Joint Pliers



- Wire cutting shear
- Polished high carbon drop forged steel
- Permalock fastener eliminates nut and bolt failure
- Channellock blue comfort grips

Item #	Length (in.)
CL526	6
CL528	8

CHANNELLOCK

Ironworkers Pliers



- Polished high carbon drop forged steel
- Dog leg handle for better leverage when twisting wire
- Coiled spring
- Channellock blue comfort grips

Item #	Length (in.)
CL350-S	8 $\frac{3}{4}$

CHANNELLOCK

Adjustable Wrenches



- Chrome vanadium finish
- Longer jaws grip better avoiding slippage or nut round-off
- Greater jaw capacity
- Thinner jaws for greater access
- Four thread knurl and non-protruding jaws

Item #	Overall Length (in.)	Jaw Capacity	UoM
CL804	4 $\frac{1}{2}$.51	Ea
CL806W	6 $\frac{1}{4}$.938	Ea
CL808W	8	1.18	Ea
CL810W	10	1.375	Ea
CL812W	12	1.5	Ea
CL815	15	1.69	Ea
CL818	18	2.13	Ea

CHANNELLOCK

Adjustable Wrenches
Wide Azz Code Blue®



- Chrome vanadium finish
- Longer jaws grip better avoiding slippage
- Wider jaw capacity
- Four thread knurl
- Code blue grips

Item #	Overall Lgth. (in.)	Jaw Capacity
CL6WCB-6	6	1.34
CL8WCB-8	8	1.50



KLEIN TOOLS

Adjustable Wrenches

Extra-Capacity Design



- Jaws open 3/16" wider than standard design wrenches
- Extra capacity allows use of a smaller size wrench to handle bigger jobs
- Ideal for use in confined spaces
- Drop-forged alloy steel for maximum strength and light weight
- Chrome plated
- Plastic-dipped handles

Item #	Length (in.)	Capacity (in.)	Handle Type
KLD507-6	6	1 $\frac{5}{16}$	Plastic-Dipped
KLD507-8	8	1 $\frac{1}{8}$	Plastic-Dipped
KLD507-10	10	1 $\frac{5}{16}$	Plastic-Dipped
KLD507-12	12	1 $\frac{1}{2}$	Plastic-Dipped



IRWIN INDUSTRIAL TOOLS

GrooveLock Pliers

WISE-GRIP



- Press and slide button quickly adjusts lower jaw
- All purpose jaw grips on round, flat, square and hex shapes
- More groove positions provide the optimum hand location for a better grip on the work piece
- ProTouch Grips provide extra comfort and reduces hand fatigue
- Ratcheting action allows GrooveLock to be adjusted from the open position up to the work piece by pushing the handle up - no need to press the button
- Anti-pinch design prevents handles from pinching

Item #	Size (in.)	Jaw Capacity (in.)	Jaw Positions	Pipe Size (in.)
VG2078108	8	1 $\frac{3}{4}$	13	1
VG2078110	10	2 $\frac{1}{4}$	16	1 $\frac{1}{2}$
VG2078112	12	2 $\frac{3}{4}$	19	2
VG2078116	16	4 $\frac{1}{2}$	21	3 $\frac{3}{4}$
VG2078120	20	6	25	4 $\frac{1}{2}$



IRWIN INDUSTRIAL TOOLS
Straight Jaw Locking Pliers
WISE-GRIP



- Straight jaw provides maximum contact on flat, square or hex materials

Item #	Description	Jaw Capacity (in.)
VG10R	10"	1 $\frac{7}{8}$
VG7R	7"	1 $\frac{1}{2}$

IRWIN INDUSTRIAL TOOLS
Curved Jaw Locking Pliers
WISE-GRIP



- Self-energizing lower jaw provides three times more gripping power, with no slipping or stripping on any style nut or bolt head

Item #	Description	Jaw Capacity (in.)
VG10CR	10"	1 $\frac{7}{8}$
VG7CR	7"	1 $\frac{1}{2}$
VG5CR	5"	1 $\frac{1}{8}$

IRWIN INDUSTRIAL TOOLS
Curved Jaw Locking Pliers with Wire Cutter
WISE-GRIP



- Curved jaw with built-in wire cutter for a great variety of applications and material shapes

Item #	Size	Jaw Capacity (in.)
VG10WR	10"	1 $\frac{7}{8}$
VG7WR	7"	1 $\frac{1}{2}$
VG5WR	5"	1 $\frac{1}{8}$
VGWR	4"	1

IRWIN INDUSTRIAL TOOLS
Long Nose Locking Pliers
WISE-GRIP



- Long, straight nose provides easy access in narrow, hard-to-reach places

Item #	Description	Jaw Capacity (in.)
VG9LN	9"	2 $\frac{3}{4}$
VG6LN	6"	2
VG4LN	4"	1 $\frac{5}{8}$

IRWIN INDUSTRIAL TOOLS
Locking C-Clamps with Regular Tips
WISE-GRIP



- Wide-opening jaws provide greater versatility in clamping a variety of shapes

Item #	Size (in.)	Jaw Capacity (in.)	Throat Depth (in.)
VG24R	24	10	15 $\frac{1}{2}$
VG18R	18	7 $\frac{1}{2}$	9 $\frac{1}{2}$
VG11R	11	4	2 $\frac{5}{8}$
VG6R	6	2 $\frac{1}{8}$	1 $\frac{1}{2}$

IRWIN INDUSTRIAL TOOLS
Locking C Clamps with Swivel Pads
WISE-GRIP



- Swivel pads hold tapered work, awkward fabricating jobs and delicate projects without damaging the work surface

Item #	Size (in.)	Jaw Capacity (in.)	Throat Depth (in.)
VG18SP	18	8	9 $\frac{1}{2}$
VG11SP	11	3 $\frac{3}{8}$	2 $\frac{5}{8}$
VG9SP	9	4 $\frac{1}{2}$	4 $\frac{3}{4}$
VG6SP	6	2	1 $\frac{1}{2}$
VG4SP	4	1 $\frac{5}{8}$	1 $\frac{1}{4}$

IRWIN INDUSTRIAL TOOLS
Locking Sheet Metal tool
WISE-GRIP



- Makes bending, forming and crimping sheet metal jobs easier

Item #	Size (in.)	Jaw Capacity (in.)
VG8R	8	3 $\frac{1}{8}$

IRWIN INDUSTRIAL TOOLS
Locking Welding Clamp
WISE-GRIP



- U-shaped jaws provide enhanced visibility and more working space

Item #	Size	Jaw Capacity (in.)
VG9R	9"	2 $\frac{3}{4}$

IRWIN Industrial Tools

IRWIN INDUSTRIAL TOOLS **Locking Chain Clamp**

VICE-GRIP

- Chain holds and locks around any shape or size



Item #	Size	Jaw Capacity (in.)
--------	------	--------------------

VG20R	9"	18
-------	----	----

IRWIN INDUSTRIAL TOOLS **Replacement Plier**

Parts

VICE-GRIP

Replacement Parts:

- 07-Replacement Screw for 10R®, 10WR®, 10CR®, 20R®, 12LC®, 11R®, 11SP®, 18R®, 18SP™, 24R™, 24SP™ and 10LW®
- 21-Replacement Screw for 7R®, 7WR®, 7CR®, 7LW®, 9LN®, 9R® and RR™
- 91-Replacement screw for 4WR®, 4LN®, 4SP™ and 4LW®
- 08-Replacement spring for 10R®, 10WR®, 10CR®, 11R®, 11SP, 20R®, 12LC® and 10LW™
- 52-Replacement spring for 5WR®, 6LN®, 6R®, and 6SP®
- 92-Replacement spring for 4WR®, 4LN®, 4SP™ 4LW®
- 20REP-Replacement chain for 20R
- 20EXT-Chain extension for 20R



Item #	Description
VG07	Adjusting Screw
VG21	Adjusting Screw
VG51	Adjusting Screw
VG91	Adjusting Screw
VG08	Replacement Spring
VG52	Replacemnt Spring
VG92	Replacement Spring
VG20REP	Replacement Chain 18"
VG20EXT	Extension Chain 18"

STANLEY

STANLEY INDUSTRIAL TOOLS **6-Way Screwdriver**

- All-in-one screwdriver with 6 tips: #1 and #2 Phillips®, 1/4" 3/16" Slotted, 1/4" and 5/16" Nut Driver
- Slip-resistant rubber grip for comfort



Item #

ST68-012M

STANLEY INDUSTRIAL TOOLS

Screwdriver Set

11-Piece Fatmax®



- Tools:
- Standard: 1/4" Stubby, 1/4" x 4", 5/16" x 6"
- Cabinet: 1/8" x 3", 3/16" x 3"
- Phillips: Opt x 2-3/8", 2pt Stubby, 1pt x 3", 2pt x 4", 3pt x 6"
- Hybrid Offset: 1/4" Slotted, 2pt Phillips
- Ergonomically designed tri-lobular handle design provides maximum tip torque
- Slip-resistant rubber grip increases user comfort
- Tip identification symbol molded onto side handle makes tip identification easy

Item #

ST62-502

STANLEY INDUSTRIAL TOOLS

Screwdriver Set

4-Piece Fatmax®



- Tools:
- Standard Tip: 1/4" x 4", Cabinet: 3/16" x 3"
- Phillips: 1pt x 3, 2pt x 4"
- Ergonomically designed tri-lobular handle design provides maximum tip torque
- Slip-resistant rubber grip increases user comfort
- Tip identification symbol molded onto side handle makes tip identification easy

Item #

ST62-505

APEX

APEX **Combination Mini Dual Material**

12-Piece GEARWRENCH



- Tools: 1.5mm Mini Slotted Screwdriver, 2.0mm Mini Slotted Screwdriver, 2.5mm Mini Slotted Screwdriver, #00 Mini Phillips Screwdriver, #0 Mini Phillips Screwdriver, #1 Mini Phillips Screwdriver, T-5 Mini Torx® Screwdriver, T-6 Mini Torx® Screwdriver, T-7 Mini Torx® Screwdriver, T-8 Mini Torx® Screwdriver, T-9 Mini Torx® Screwdriver, T-10 Mini Torx® Screwdriver

Item #

GW80057



MIDWEST TOOL & CUTLERY

Offset Aviation Snips

- Hot-drop forged steel handles
- Heavy duty spring
- Soft grip handles
- Capacity of cutting 18 ga. cold-rolled sheet metal and 22 ga. stainless steel sheet metal



Item #	Description	Handle Color	Cutting Capacities (in.)
MDWP6510 L	Offset Left Cut	Red	1¼
MDWP6510 R	Offset Right Cut	Green	1¼
MDWP6510 S	Offset Straight Cut	Yellow	1½

MIDWEST TOOL & CUTLERY

Aviation Snips

- Hot-drop forged steel handles
- Heavy duty spring
- Soft grip handles
- Capacity of cutting 18 ga. cold-rolled sheet metal and 22 ga. stainless steel sheet metal



Item #	Description	Handle Color	Cutting Capacities (in.)
MDWP6716 L	Left Cut	Red	1¾
MDWP6716 R	Right Cut	Green	1¾
MDWP6716 S	Straight Straight	Yellow	1½



COOPER HAND TOOLS

Aluminum Snips

Wiss®

- Cuts straight, and curves (light gauge)
- For light gauge metal, flash, vinyl siding, gutter, net, rubber
- 3-1/2" blades, drop forged for long life
- Cutting Capacity: 23 gauge low carbon steel



Item #
CGW12MP

COOPER HAND TOOLS

Aviation Snips

Wiss®



- Non-slip serrated jaw of molybdenum steel withstands strain of cutting heavy stock
- Spring action for fast, effortless feed
- Non-slip textured grips and safety latch
- Maximum cutting capacity 18 ga. steel
- Length: 9-3/4"
- Length of Cut: 1-3/8"

Item #	Desc.	Handle Color
CGM1R	Left Cut	Red
CGM2R	Right Cut	Green
CGM3R	Straight Cut	Yellow



IRWIN INDUSTRIAL TOOLS

Aviation Snips

- Hot-drop forged steel blades
- Ergonomic ProTouch™ grips
- Cutting Capacity: 18 ga. steel, 23 ga. stainless steel
- Length: 10"
- Length of Cut: 1-5/16"



Item #	Description	Handle Color
IR2073111	Left Cut	Red
IR2073112	Right Cut	Green
IR2073113	Straight Cut	Yellow

IRWIN INDUSTRIAL TOOLS

Offset Snips

- Multiple pivot pins provide compound cutting action
- Cut at a sharper angle, distancing your hands from sharp, jagged work surfaces
- Cuts straight and angles or curves left
- Cutting Capacity: Cold- roll Steel 18 ga. Stainless Steel 23 ga.
- Length: 9-1/2"
- Length of Cut: 1-5/16"



Item #	Description	Handle Color
IR2073211	Left Cut	Red
IR2073212	Right Cut	Green

IRWIN Industrial Tools

IRWIN INDUSTRIAL TOOLS

Tinner Snip

- Precision-ground blade edges ensure quality cuts
- Hot-drop forged steel blades provide maximum strength
- Double-dipped vinyl handles
- Cutting Capacity: 20 ga. steel, 22 ga. stainless steel
- Length: 12-3/4"
- Length of Cut: 2-3/4"



Item #
VG012



COOPER HAND TOOLS

Hand Seamers

Wiss®

- Used to bend and flatten sheet metal
- Optimal handle span for maximum power and comfortable operating range
- Non-slip cushion grips for superior comfort and control
- 1-1/4" maximum seam depth
- 1/4" depth markings



Item #	Size (in.)
CGWS3	3
CGWS6	6

COOPER HAND TOOLS

Folding tool

Wiss®

- Ideal for folding channels and making longer uniform folds
- Fold 3/8" and 1" depths
- Sight holes to help assure proper depth alignment



Item #	Description
CGWF18	18"

COOPER HAND TOOLS

Hand Crimpers

Wiss®

- Crimps male fitting end to connect guttering, down spouts or metal pipe
- Optimal handle span for maximum power and comfortable operating range
- Non-slip cushion grips for superior comfort and control
- 5 Blade Crimper, 1-1/4" depth



Item #
CGWC5S

COOPER HAND TOOLS

Hand Notcher

Wiss®

- Cuts 30 degree V shaped cut in sheet metal
- Gives clean notch without slipping at corners and take-off tabs
- Non-slip cushion grips for superior comfort and control
- Blade Length: 13/16 in.
- Tool Length: 8 3/4 in.
- Jaw/Throat Depth: 13/16 in.



Item #
CGWHN1



LEATHERMAN

Kick® - Multi-Tool

12-Tools-in-1

- Stainless steel handles/body with Zytel® comfort-grip inserts
- Tools - 420HC clip point knife, needle-nose pliers, regular pliers, wire cutters, wire stripper, large/small screwdriver, Phillips screwdriver, bottle/can opener & 8" ruler
- 4" length



Item #
LE830019



LEATHERMAN
Fuse® - Multi-Tool

13-Tools-in-1

- One-at-a-time blade selection that gets you just the tool you want
- Tools - 420HC clip point knife, needlenose pliers, regular pliers, wire cutters, hard-wire cutters, wire stripper, large/small screwdriver, Phillips screwdriver, scissors, bottle/can opener & 8" ruler
- 4" length



Item #
LE830026

LEATHERMAN
Blast® - Multi-Tool

16-Tools-in-1 with 1 Bit

- Stainless steel handles with Zytel® comfort-grip inserts
- Longer blades mean easier slicing, sawing, filing and more
- Tools - 420HC clip point knife, needlenose pliers, regular pliers, wire cutters, hard-wire cutters, wire stripper, large/small screwdriver, Phillips screwdriver, small bit driver, scissors, wood/metal file, saw, bottle/can opener, 8" ruler & Phillips/flat tip eyeglasses screwdriver bit
- 4" length



Item #
LE830033

LEATHERMAN
Wave® - Multi-Tool

17-Tools-in-1 with 2 Bits

- Outside-accessible blades for one-handed opening
- Tools - 420HC clip point knife, 420HC sheepsfoot serrated knife, needlenose pliers, regular pliers, wire cutters, hard-wire cutters, wire stripper, large/small screwdriver, Phillips screwdriver, small bit driver, scissors, wood/metal file, diamond-coated file, saw, bottle/can opener, 8" ruler & Phillips/flat tip eyeglasses screwdriver bit, Phillips #1-2 and 3/16" bit
- 4" length



Item #
LE830040

LEATHERMAN
Core® - Multi-Tool

19-Tools-in-1

- Tools - 420HC clip point knife, 420HC sheepsfoot serrated knife, needlenose pliers, regular pliers, wire cutters, hard-wire cutters, stranded-wire cutters, wire stripper, 5/16"-7/32"-1/8" screwdrivers, Phillips screwdriver, wood/metal file, saw, bottle/can opener, 8" ruler & awl with thread loop
- 4-1/2" length



Item #
LE830147

LEATHERMAN
Surge® - Multi-Tool

18-Tools-in-1 with 2 Bits

- Stainless steel handles/body
- Outside-accessible blades for one-handed opening
- Blade exchanger, with all locking blades & tools
- Tools -420HC clip point knife, 420HC sheepsfoot serrated knife, needlenose pliers, regular pliers, wire cutters, hard-wire cutters, stranded-wire cutters, wire stripper, electrical crimper, large/small bit driver, scissors, wood/metal file, diamond-coated file, saw, bottle/can opener, 9" ruler, awl with thread loop & Phillips/flat tip eyeglasses screwdriver bit, Phillips #1-2 and 3/16" screwdriver bit
- 4-1/2" length



Item #
LE830161

LEATHERMAN
Charge AL® - Multi-Tool

17-Tools-in-1 with 8 Bits

- Stainless steel with 6061-T6 hard-anodized aluminum handle scales
- Outside-accessible blades for one-handed opening
- All locking blades & tools
- Tools -154CM stainless steel clip point knife, 420HC Sheepsfoot serrated knife, needlenose pliers, regular pliers, wire cutters, hard-wire cutters, wire stripper, large screwdriver, large/small bit driver, scissors, wood/metal file, diamond-coated file, saw, bottle/can opener, 8" ruler & Phillips/flat tip eyeglasses screwdriver bit, Hex 5/32" and 9/64" Bit, Hex 1/8" and 7/64" Bit, Hex 3/32" and 5/64" Bit, Hex 1/16"
- 4" length



Item #
LE830665

LEATHERMAN

LEATHERMAN

Charge ALX® - Multi-Tool

18-Tools-in-1 with 9 Bits

- Stainless steel with 6061-T6 hard-anodized aluminum handle scales
- Outside-accessible blades for one-handed opening
- All locking blades & tools
- Tools -154CM stainless steel clip point knife, 420HC sheepsfoot serrated knife with cutting hook, needle-nose pliers, regular pliers, wire cutters, hard-wire cutters, wire stripper, wire crimper, two large/one small bit driver, wood/metal file, diamond-coated file, saw, bottle/can opener, 8" ruler & Phillips/flat tip eyeglasses screwdriver bit, Hex 5/32" and 9/64" Bit, Hex 1/8" and 7/64" Bit, Hex 3/32" and 5/64" Bit, Hex 1/16"
- 4" length



Item #
LE830677

LEATHERMAN

Skeletool - Multi-Tool

7-Tools-in-1

- Stainless Steel Body
- AL Handle Insert
- Accessories: Needlenose Pliers, Regular Pliers, Wire Cutters, Hard-wire Cutters, Combo Knife, Bit Driver, Bottle Opener, Removable Pocket Clip



Item #	Options	Closed Length (in.)	Blade Length (in.)	Weight (oz.)
LE830948	Standard Sheath	4	2.6	5

LEATHERMAN

Juice CS4 - Multi-Tool

15-Tools-in-1

- Stainless Steel Body
- Anodized AL Handle Scales
- Accessories: Needlenose Pliers, Regular Pliers, Knife, Saw, Wire Cutters, Hard-wire Cutters, Extra-small Screwdriver, Small Screwdriver, Med/Lrg Screwdriver, Phillips Screwdriver, Bottle Opener, Can Opener, Awl Scissors, Corkscrew, Corkscrew Assist, Lanyard Ring



Item #	Color	Closed Length (in.)	Blade Length (in.)	Weight (oz.)
LE74204003K	Glacier Blue	3.25	2.6	5.5

LEATHERMAN

Super Tool 300 - Multi-Tool

19-Tools-in-1

- Stainless Steel Body
- Accessories: Needlenose Pliers, Regular Pliers, Wire Cutters, Electrical Crimper, Knife, Serrated Knife, File, Saw, Screwdrivers, Awl, Ruler, Bottle Opener, Can Opener, Wire Stripper, Lanyard Ring



Item #	Options	Closed Length (in.)	Blade Length (in.)	Weight (oz.)
LE831181	Standard Sheath	4.5	3.2	9.6

LEATHERMAN

Wingman - Multi-Tool

14-Tools-in-1

- Stainless Steel body
- Accessories: Needlenose Pliers, Regular Pliers, Wire Cutters, Combo Knife, Package Opener, File, Scissors, Screwdrivers, Ruler, Bottle Opener, Can Opener, Wire Stripper, Removable Pocket Clip



Item #	Closed Length (in.)	Blade Length (in.)	Weight (oz.)
LE831425	3.8	2.6	7.0

LEATHERMAN

Squirt PS4 - Multi-Tool

9-Tools-in-1

- Stainless Steel Body
- Anodized AL Handle Scales
- Accessories: Needlenose Pliers, Regular Pliers, Wire Cutters, Knife, Scissors, Wood/Metal File, Medium Screwdriver, Flat/Phillips Screwdriver, Bottle Opener, Key Ring Attachment



Item #	Col or	Closed Length (in.)	1Blade Length (in.)	Weight (oz.)
LE831188	Red	2.25	1.6	1.9

LEATHERMAN

Micra - Multi-Tool

10-Tools-in-1

- Stainless Steel Body
- Accessories: Spring-action Scissors, Knife, Nail file, Nail Cleaner, Tweezers, Extra-small Screwdriver, Medium Screwdriver, Flat/Phillips Screwdriver, Ruler, Bottle Opener, Key Ring Attachment



Item #	Color	Closed Length (in.)	Blade Length (in.)	Weight (oz.)
LE64010103K	Stainless Steel	2.5	1.6	1.8



STANLEY

STANLEY INDUSTRIAL TOOLS

**Utility Knife
Classic 99®**



- Patented interlocking nose to hold blade securely
- Three-position retractable blade
- Die-cast handle is durable and lightweight
- Blade storage in handle

Item #
ST10-099

STANLEY INDUSTRIAL TOOLS

**Utility Knife
Classic 199®**



- Positive fixed blade retention
- Heavy-duty die-cast aluminum handle
- Blade storage in handle

Item #
ST10-209

STANLEY INDUSTRIAL TOOLS

**QUICK CHANGE™
Utility Knife
Retractable**



- Three position retractable blade slide
- Swing-out blade storage magazine
- Integrated string cutter

Item #
ST10-499

STANLEY INDUSTRIAL TOOLS

**Retractable Utility
Knife
DynaGrip™**



- Patented interlocking nose secures blade
- Slip resistant grip resists slipping -even on angled surfaces
- Hi-vis yellow handle

Item #
ST10-779

STANLEY INDUSTRIAL TOOLS

**18 mm Snap Off Knife
FatMax®**



- Stainless steel barrel is rust resistant for longer life
- Cartridge holds up to 6 blades

Item #
ST10-481

STANLEY INDUSTRIAL TOOLS

**Retractable Utility
Knife
FatMax®**



- Blade clamp eliminates blade wobble, gives more control
- Pop-up blade dispenser for easier access and faster changeover
- Push button blade change

Item #
ST10-778

STANLEY INDUSTRIAL TOOLS

**Fixed Blade Utility
Knife
FatMax®**



- Dual blade position in nose increases versatility
- Pop-up blade dispenser for easier access and faster changeover
- Cartridge holds up to 5 blades

Item #
ST10-780

STANLEY INDUSTRIAL TOOLS

**Quick Slide Sport
Utility Knife**



- Great for multi purpose cutting
- 3" serrated sport blade
- Spine lock button for ease and security
- Easy blade change
- Interlocking nose prevents spreading

Item #
ST10-813M

STANLEY INDUSTRIAL TOOLS

Putty Knives



- Steel blade hardened, tempered and polished
- Full tang blade permanently fastened to shatter-resistant nylon handle
- Stiff blade

Item #	Blade Width (in.)
ST28-140	1¼
ST28-141	1½
ST28-142	2

STANLEY INDUSTRIAL TOOLS

Wall Scrapers



- High carbon steel—hardened, tempered and polished
- Full tang blade permanently fastened to shatter-resistant nylon handle
- Stiff 3" wide blade

Item #
ST28-139

STANLEY

STANLEY INDUSTRIAL TOOLS
Razor Blade Scraper

- Blade retracts for safety
- Uses single edge razor blade
- Comes with 5 blades



Item #
ST28-500

STANLEY INDUSTRIAL TOOLS
Mini-Razor Scraper

- Great for scraping in hard to reach places
- High-visibility yellow makes it easy to find
- Lightweight and economical plastic razor blade scraper
- Blade reverses for safe storage
- Uses standard, single-edge razor blade



Item #
ST28-100

STANLEY INDUSTRIAL TOOLS
Replacement Utility Knife Blades

FatMax®



Custom heat treatment makes blade strong and resistant to breakage

Item #	Pack (Qty.)
ST11-700	5
ST11-700L	50 w/ dispenser
ST11-700A	100 w/ dispenser

STANLEY INDUSTRIAL TOOLS
Razor Blades

- Single edge replacement blades for Stanley® 28-100 and 28-500 scrapers
- Packed 10 per box



Item #
ST28-510

STANLEY INDUSTRIAL TOOLS
18 mm Replacement Blades
Quick-Point™



- Replacement blade with 8 cutting points
- Fits most 18 mm snap-off blade knives
- 10 blades per dispenser

Item #
ST11-301T

STANLEY INDUSTRIAL TOOLS
Replacement Snap Off Blades
FatMax®



- Fits 18mm. snap blade knives
- Bendable/shatter resistant
- 10 blades per pack

Item #
ST11-718T

STANLEY INDUSTRIAL TOOLS
Replacement Roofing Utility Blades



- Edge is engineered to withstand the rigors of cutting heavier and thicker roofing materials
- Cuts roofing shingles, felt paper, Tyvek®, foam board, insulation, shingles and other building materials
- Designed for use in fixed blade knives only

Item #	Pack (Qty.)
ST11-939	3
ST11-939A	70

IRWIN
Industrial Tools

IRWIN INDUSTRIAL TOOLS
Utility Knife
Retractable Blade



- Smooth, three-position slide exposes variable blade lengths
- Screw permanently captured in casing to prevent loss
- Inside storage for 5 blades
- Includes 1 Irwin Blue Blade Bi-Metal utility blade

Item #
IR2082101



IRWIN INDUSTRIAL TOOLS

Utility Knife

Retractable Blade
ProTouch™



- Quick-change mechanism allows for easy blade removal without opening
- Easy tool-free entry with push button operation opens the knife and exposes replacement blades
- Inside storage for 5 blades
- Includes 3 Irwin Blue Blade™ Bi-Metal Utility Blades

Item #
IR2082200

IRWIN INDUSTRIAL TOOLS

Utility Knife Blades

Blue Blade™



- Features patented Bi-Metal technology
- Spring steel body delivers superior flexibility to prevent breaking
- High speed steel cutting edge stays sharp longer
- Fits most utility knives

Item #	Pkg. Qty.
IR2084100	5
IR2084300	50 w/ dispenser
IR2084400	100 w/ dispenser



PFERD ABRASIVES

Flat Files



- Double cut on both sides and are single cut on both edges
- Used on ferrous and non-ferrous metals for rapid stock removal

Item #	Length (in.)	Cut
PF11009	8	Smooth
PF11012	10	Smooth
PF11013	12	Bastard
PF11015	12	Smooth
PF11016	14	Bastard

PFERD ABRASIVES

Half Round Files



- Used for filing out concave surfaces and crevices, and for rounding out holes
- Flat side is double-cut
- Half round side is spiral cut

Item #	Length (in.)	Cut
PF11026	10	Bastard
PF11028	10	Smooth
PF11029	12	Bastard
PF11032	14	Bastard

PFERD ABRASIVES

Knife Files



- Used on slots and keyways and for acute angle work in diemaking
- Sides are double cut and the thin edge is cut but the back is safe (uncut)

Item #	Length (in.)	Cut
PF11054	6	Smooth
PF11059	10	Second

PFERD ABRASIVES

Round Files



- Designed for enlarging circular holes or rounded grooves that are too small for a half round file
- It tapers toward the point making it adaptable for use on various size holes

Item #	Length (in.)	Cut
PF11073	12	Bastard
PF11076	14	Bastard

PFERD ABRASIVES

Machinist's Files



- Packaged
- Easy Grip Handle

Item #	Length (in.)	Desc.	Cut
PF11007P	8	Flat	Bastard
PF11010P	10	Flat	Bastard
PF11023P	8	Half Round	Bastard
PF11067P	8	Round	Bastard
PF11100P	8	Three Square	Bastard
PF11105	6	Flat	Second



PFERD ABRASIVES
Square Files



- Handy for use on slots, key-ways, rectangular or square holes and for surface work
- Has four equal sides (5/16")
- Double cut, it tapers toward the point

Item #	Length (in.)	Cut
PF11087	8	Bastard

PFERD ABRASIVES
Tapered Mill Files



- Suitable both as engineering and sharpening files
- Useful for filing where a smooth finish is important
- Good for polishing and deburring work in lathes
- Widely applicable for sharpening tools and implements
- Two square edges. Single cut on sides and edges

Item #	Length (in.)	Cross-section (in.)	Cut
PF19003	6	1 ⁹ / ₃₂ x 7/64	Smooth
PF19010	12	1 ⁵ / ₃₂ x 7/32	Bastard

PFERD ABRASIVES
Tapered Mill Files



- Easy grip handle
- Packaged

Item #	Length (in.)	Cut	UoM
PF19001P	6	Bastard (Cut 1)	Ea
PF19004P	8	Bastard (Cut 1)	Ea

PFERD ABRASIVES
Flat Plus Files



- Easy grip handle
- Packaged

Item #	Size (in.)	Length (in.)	Cut
PF11135P	3 ¹ / ₃₂ x 1/4	10	PLUS Cut

PFERD ABRASIVES
Three Square Files



- Double cut and have fairly sharp corners that are slightly set and cut
- For filing internal angles more acute than the right angle, for clearing out square corners and filing taps and cutters

Item #	Size (in.)	Cut
PF11104	10 x 3/4	Second

PFERD ABRASIVES
File Handles



- Plastic file handle
- Air gaps absorb hand moisture
- Long lasting, reusable

Item #	Suitable For	Compatible For File Length (in.)
PF11130	Very Narrow Tangs	4-6
PF11131	Regular Tangs	4-6
PF11132	All Tangs	8-10
PF11133	12-14 All Tangs	12-14



TRIUMPH TWIST DRILL CO.
Hex Rethreading Dies

Heavy-Duty

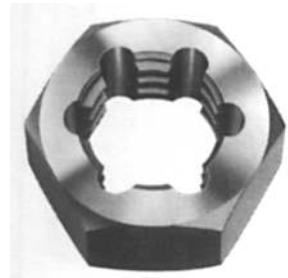

- W109HD Fractional
- Dies made the same size as matching nut, eliminating the need for more than one wrench
- Used to repair badly damaged or rusted threads
- Designed to chase damaged threads, nicks and burrs without undercutting good threads

Item #	Size-Pitch	Thrd	Across Flats
TR69550	1/4-20	NC	19/32
TR69552	5/16-18	NC	11/16
TR69554	3/8-16	NC	25/32
TR69555	3/8-24	NF	25/32
TR69556	7/16-14	NC	7/8
TR69558	1/2-13	NC	1-1/16
TR69559	1/2-20	NF	1-1/16
TR69560	9/16-12	NC	1-1/16
TR69561	9/16-18	NF	1-1/16
TR69562	5/8-11	NC	1-1/4
TR69563	5/8-11	NF	1-1/4
TR69566	3/4-10	NC	1-7/16
TR69567	3/4-16	NF	1-7/16
TR69568	7/8-9	NC	1-5/8
TR69569	7/8-14	NF	1-5/8
TR69570	1-8	NC	1-13/16



TRIUMPH TWIST DRILL CO.

Taps

HSS Thundertap®



- Bronze oxide surface treatment for easier tapping, higher speeds and greater abrasion resistance
- Precision ground cutting surfaces for precise thread production

Item #	Size-Pitch	Thread	Thread Limit	Drill Size
--------	------------	--------	--------------	------------

T61HDT Taper (7-10 threads long)

TR71000	1/4-20	NC	H3	7
TR71001	1/4-28	NF	H3	3
TR71002	5/16-18	NC	H3	F
TR71003	5/16-24	NF	H3	I
TR71004	3/8-16	NC	H3	5/16
TR71006	7/16-14	NC	H3	U
TR71007	7/16-20	NF	H3	25/64
TR71008	1/2-13	NC	H3	27/64
TR71009	1/2-20	NF	H3	29/64
TR71010	9/16-12	NC	H3	31/64
TR71011	9/16-18	NF	H3	33/64
TR71012	5/8-11	NC	H3	17/32
TR71013	5/8-18	NF	H3	37/64
TR71014	3/4-10	NC	H3	21/32
TR71015	3/4-16	NF	H3	11/16
TR71016	7/8-9	NC	H4	49/64
TR71017	7/8-14	NF	H4	13/16
TR71018	1-8	NC	H4	7/8
TR71019	1-12	NF	H4	59/64
TR71020	1 1/8 -7	NC	H4	63/64

T62HDT Taper

TR71041	6-32	NC	H3	36
TR71043	8-32	NC	H3	29
TR71045	10-24	NC	H3	25
TR71046	10-32	NF	H3	21
TR71047	12-24	NC	H3	16

T61HDP Plug (3-5 threads long)

TR71068	1/2-13	NC	H3	27/64
---------	--------	----	----	-------

T61HDB Bottoming (1-2 threads long)

TR71100	1/4-20	NC	H3	7
TR71101	1/4-28	NF	H3	3
TR71102	5/16-18	NC	H3	F
TR71103	5/16-24	NF	H3	I
TR71104	3/8-16	NC	H3	5/16

Item #	Size-Pitch	Thread	Thread Limit	Drill Size
--------	------------	--------	--------------	------------

TR71105	3/8-24	NF	H3	Q
TR71107	7/16-20	NF	H3	25/64
TR71108	1/2-13	NC	H3	27/64
TR71109	1/2-20	NF	H3	29/64
TR71110	9/16-12	NC	H3	31/64
TR71111	9/16-18	NF	H3	33/64
TR71112	5/8-11	NC	H3	17/32
TR71113	5/8-18	NF	H3	37/64
TR71114	3/4-10	NC	H3	21/32
TR71115	3/4-16	NF	H3	11/16
TR71116	7/8-9	NC	H4	49/64
TR71118	1-8	NC	H4	7/8
TR71119	1-12	NF	H4	59/64

T62HDB Bottoming (1-2 threads long)

TR71141	6-32	NC	H3	36
TR71143	8-32	NC	H3	29
TR71145	10-24	NC	H3	25
TR71146	10-32	NF	H3	21
TR71147	12-24	NC	H3	16

TRIUMPH TWIST DRILL CO.

Tap & Die Set

38-Piece



- Molded Case with 17 Plug Taps, 16 Round Dies (1" O.D.)
- 1/4-20 NC, 5/16-18 NC, 3/8-16 NC, 7/16-14 NC, 1/2-13 NC, 4-40 NC, 6-32 NC, 8-32 NC, 10-24 NC, 12-24 NC, 1/4-28 NF, 5/16-24 NF, 3/8-24 NF, 7/16-20 NF, 1/2-20 NF, 10-32 NF, 4-36 NS
- Accessories Include: 1/8-27 NPT Round Dies, 1/8-27 NPT Pipe Tap, TRD47 Round Die Stock, JT20 Tap Wrench, JT40 Tap Wrench

Item #

TR69961

TRIUMPH TWIST DRILL CO.

Tap & Die Set

HSS



- T513 - Molded Case
- 1/4-20 NC, 5/16-18 NC, 3/8-16 NC, 7/16-14 NC, 1/2-13 NC, 4-40 NC, 6-32 NC, 8-32 NC, 10-24 NC, 12-24 NC, 1/4-28 NF, 5/16-24 NF, 3/8-24 NF, 7/16-20 NF, 1/2-20 NF, 10-32 NF, 4-36 NS
- Accessories Include: 1/8-27 NPT Hex Die, TRD50 Hex Die Stock, 1/8-27 NPT Pipe Tap, JT40 Tap Wrench, JT20 Tap Wrench

Item #

TR69963



TRIUMPH TWIST DRILL CO.
Combination Tap and Drill Set

18-Piece
Thunderbit®/Thundertap®



- TD18HDNC - Metal Index
- ThunderBit®: 7, F, 5/16, U, 27/64, 36, 29, 25, 16
- ThunderTap®: 1/4-20 NC, 5/16-18 NC, 3/8-16 NC, 7/16-14 NC, 1/2-13 NC, 6-32 NC, 8-32 NC, 10-24 NC, 12-24 NC

Item #
TR71497

TRIUMPH TWIST DRILL CO.
Tap Set

HSS

- WC39 - Vinyl Pouch
- 10 Piece Pitch Range - 6-32 NC, 8-32 NC, 10-24 NC, 10-32 NF, 1/4-20 NC
- Jobber Drill Size Range (Wire) - 36, 29, 25, 21, 7



Item #
TR69939

TRIUMPH TWIST DRILL CO.
Tap Wrenches

T-Handle

- Sliding T-handle is ideal for turning in confined areas
- Strong and rugged for easy handling and accurate tapping



Item #	Capacity
TR69902	0 to 1/4
TR69903	12 to 5/16
TR69904	1/4 to 1/2

TRIUMPH TWIST DRILL CO.
Tap Wrenches



Straight Handle

- Strong and rugged for easy handling and accurate tapping

Item #	Style	Capacity
TR69905	JTW5	10 to 1/2
TR69907	JTW7	3/8 to 1

TRIUMPH TWIST DRILL CO.
Screw Extractors



- Carbon Steel/Gray
- Remove broken screws, bolts and studs quickly and easily
- Heat-treated finish to resist rust
- Also for turning threaded pipe sections

Item # Screw Ext. # For Removing Screw Size: Use Drill Size:

T13CX

TR98136	6	5/8 to 7/8, 3/8 Pipe	25/64 to 27/64
TR98137	7	7/8 to 1 1/8, 1/2 Pipe	33/64 to 35/64
TR98138	8	1 1/8 to 1 3/8, 3/4 Pipe	25/32 to 27/32
TR98139	9	1 3/8 and Up, 1 Inch Pipe	1 1/16 to 1 1/8

BP13CX

TR98231	1	3/32 to 5/32	1/16 to 5/64
TR98232	2	5/32 to 7/32	3/32 to 7/64
TR98233	3	7/32 to 9/32	9/64 to 5/32
TR98234	4	9/32 to 3/8	7/32 to 1/4
TR98235	5	3/8 to 5/8, 1/8 & 1/4 Pipe	17/64 to 19/64

TRIUMPH TWIST DRILL CO.
Alignment Reamers



- 1/2" Shank, (77280 has 3/8 shank)
- High Speed Steel
- Black and Bronze Oxide
- 3 flats on shank prevents slippage in 3-jaw chuck
- Collar stop to prevent damage to drill chuck
- Made In USA

Item # Size Decimal Equivalent Flute Length Overall Length

TR72280	3/8	.3750	3	5
TR72281	1/2	.5000	3 15/16	5 15/16
TR72282	9/16	.5625	3 15/16	5 15/16
TR72283	5/8	.6250	4 1/2	6 9/16
TR72284	1 1/16	.6875	4 1/2	6 9/16
TR72285	3/4	.7500	4 15/16	7
TR72286	13/16	.8125	4 15/16	7
TR72287	7/8	.8750	5 3/16	7 1/4
TR72289	1"	1.000	5 3/16	7 1/4



KLEIN TOOLS

Folding Hex Key Sets

5-Piece Inch

- Tough, heat-treated chrome-nickel alloy steel
- Hex-key ends are square-cut for a secure full-depth fit
- Helps prevent slippage and stripping of the socket
- Sizes: 3/16", 7/32", 1/4", 5/16" and 3/8"
- Handle Length: 5-1/4"; Key Lengths: 3" to 4-5/8"



Item #

KL70579

KLEIN TOOLS

Folding Hex Key Sets

8-Piece Inch

- Tough, heat-treated chrome-nickel alloy steel
- Hex-key ends are square-cut for a secure full-depth fit
- Helps prevent slippage and stripping of the socket
- Sizes: .050", 1/16", 5/64", 3/32", 7/64", 1/8", 9/64" and 5/32"
- Handle Length: 3-1/16"; Key Lengths: 1-1/2" to 2-3/8"



Item #

KL70581

KLEIN TOOLS

Folding Hex Key Sets

9-Piece Inch

- Tough, heat-treated chrome-nickel alloy steel
- Hex-key ends are square-cut for a secure full-depth fit
- Helps prevent slippage and stripping of the socket
- Sizes: 5/64", 3/32", 7/64", 1/8", 9/64", 5/32", 3/16", 7/32" and 1/4"
- Handle Length: 4-1/4"; Key Lengths: 1-3/4" to 3-1/2"



Item #

KL70591

KLEIN TOOLS

Folding Hex Key Sets

8-Piece Inch

- Tough, heat-treated chrome-nickel alloy steel
- Hex-key ends are square-cut for a secure full-depth fit
- Helps prevent slippage and stripping of the socket
- Sizes: 3/32", 7/64", 1/8", 9/64", 5/32", 3/16", 7/32" and 1/4"
- Handle Length: 5-1/4"; Key Lengths: 3-3/8" to 4-5/8"



Item #

KL70583

KLEIN TOOLS

Folding Hex Key Sets

7-Piece Metric

- Tough, heat-treated chrome-nickel alloy steel
- Hex-key ends are square-cut for a secure full-depth fit
- Helps prevent slippage and stripping of the socket
- Sizes: 1.5 mm, 2 mm, 2.5 mm, 3 mm, 4 mm, 5 mm and 6 mm
- Handle Length: 3-5/8" (92 mm), Key Lengths: 1-5/8" to 3" (41 to 76 mm)



Item #

KL70582

KLEIN TOOLS

Folding Hex Key Sets

5-Piece Metric

- Two key positions (straight-out or right angle) for extra leverage
- Hex ends are square-cut for a secure full-depth fit and maximum contact with the hex socket to prevent slippage and stripping of the socket
- Sizes: 4 mm, 5 mm, 6 mm, 8 mm, 10 mm
- Handle Length: 133 mm
- Key Lengths: 82 mm-117 mm



Item #

KL70580

Looking for other Klein products such as tools & bags?

Look in the "Mechanical & Electrical Work Equipment" chapter.



KLEIN TOOLS

Folding Screwdriver Sets

7 Pc. Torx®



- Set containing seven popular sizes; T10, T15, T20, T25, T27, T30 and T40
- Torx "star" drive cuts slippage, saves fasteners, efficiently transmits more torque to the work
- Keys are tough, heat-treated chrome-nickel alloy steel for strength and durability
- Keys fold flat into handle

Handle length: 4-1/4", blade length: 2-1/8" to 3"

Item #

KL70586



APEX

Fold-Up Hex Key Sets

Allen®

- Nickel-Chrome-Moly alloy steel provides outstanding torque strength
- All hex keys are precision formed to exact dimensional tolerances for precise fit



Item #	Type	No. of Keys	Key Sizes (in.)	Color
AN56074	Standard	9	5/64, 3/32, 7/64, 1/8, 9/64, 5/32, 3/16, 7/32, 1/4	Hi-Vis Orange
AN56076	Metric	7	1.5, 2, 2.5, 3, 4, 5, 6	Hi-Vis Blue
AN56897	Torx	7	T10, T15, T20, T25, T27, T30, T40	Hi-Vis Green

APEX

Fold-Up Hex Keys

Allen®

- Heat treated, tempered alloy steel provides high strength and resistance to rotational distortion
- Rotates to 270 degrees to a firm top for better torquing and access
- Specially contoured handle for better feel and control
- Rugged Duracast® case provides unmatched durability



Item #	Key Sizes (in.)	Handle Length (in.)
AN56346	.050, 1/16, 5/64, 3/32, 7/64, 1/8, 9/64, 5/32, 3/16	3 1/2

APEX

Short Arm Hex Key Set

In Vinyl Pouch

Allen®



- All hex keys are precision formed to exact dimensional tolerances for precise fit
- Heat-treated, tempered alloy steel provides high strength and resistance to rotational distortion
- Pouch

Item #	No. of Keys	Key Sizes (in.)
AN56122	9	5/64, 3/32, 7/64, 1/8, 9/64, 5/32, 3/16, 7/32, 1/4
AN56030	11	.050, 1/16, 5/64, 3/32, 1/8, 5/32, 3/16, 7/32, 1/4, 5/16, 3/8

APEX

Hex Key Set

15-Piece Long Arm

Allen



Contains keys in the following sizes:

- 5/64", 3/32", 7/64", 1/8", 9/64", 5/32", 3/16", 7/32", 1/4", 5/16", 3/8", 1/2", 9/16", 5/8", 3/4"
- Pouch

Item #

AN56014

APEX

Hex Key Set

9-Piece Metric Short Arm

Allen



Contains keys in the following sizes:

- 1-1/2 mm, 2 mm, 2-1/2 mm, 3 mm, 4 mm, 5 mm, 6 mm, 8 mm, 10 mm
- Pouch

Item #

AN56015

APEX

Hex Key Set

6-Piece Torx Long Arm

Allen



Contains:

- T-10, T-15, T-20, T-25, T-27, T-30

Item #

AN56900



APEX

APEX
Hex Key Set

18-Piece Metric Short Arm Allen®

- Contains Following Sizes: .028, .035, .050, 1/16, 5/64, 3/32, 7/64, 1/8, 9/64, 5/32, 3/16, 7/32, 1/4, 5/16, 3/8, 1/2, 9/16 and 5/8
- Metal box



Item #
AN56026

APEX
Short Arm Hex Keys Allen®

- Manufactured with heat-treated alloy steel, black finish to precision tolerances



Item #	Key Sizes (in.)
AN57020	5/32
AN57022	3/16
AN57026	1/4

APEX
T Handle Hex Key Set Allen®

- Contains 10 keys in following sizes: 3/32, 7/64, 1/8, 9/64, 5/32, 3/16, 7/32, 1/4, 5/16 and 3/8
- 9" long
- Cushion grips
- Metal stand



Item #
AN56064

VAUGHAN

VAUGHAN & BUSHNELL MFG.
Professional Rip Hammer

- Superb balance and comfortable grip
- White hickory handle is triple wedged



Item #	Desc.	Head (oz.)	Length (in.)
VB999	"999" Framing, Smooth Face	20	14
VB707M	707M Super Framing, Milled Face	32	18

VAUGHAN & BUSHNELL MFG.
California Framer® Hammer



- Head is forged of high carbon steel, triple zone heat treated, precision machined and polished
- Milled face grips nail heads to minimize slipping and flying nails
- Handle is triple-wedged into eye with wood and steel wedges
- Extra-long hickory handle, shaped for strength and comfort

Item #	Desc.	Head (oz.)	Length (in.)
VBCF1	Milled Face - Straight Handle	23	17
VBCF1HC	Milled Face - Curved Handle	23	18
VBCF1P	Smooth Face - Straight Handle	23	17
VBCF3	Milled Face - Straight Handle	27	18

AUGHAN & BUSHNELL MFG.
Bluemax® High Performance Framing Hammer



- Features the innovative magnetic nail holding slot, capable of holding both 16D and 20D nails
- Forged from high carbon steel and triple zone heat treated with an extra long, blue stained American hickory handle
- Exclusive triple wedge design locks head to handle for maximum strength

Item #	Desc.	Head (oz.)	Length (in.)
VBCFB2HCM	Milled Face - Curved Handle	19	17
VBCFB21FG	Fiberglass, Milled Face - Straight Handle	21	16
VBCFB21HC	Fiberglass, Milled Face - Curved Handle	21	17
VBCFB1HCM	Milled Face - Curved Handle	23	18
VBCFB1LM	Milled Face - Straight Handle	23	17

VAUGHAN & BUSHNELL MFG.
Steel Eagle® Professional Hammer



- Forged entirely of high carbon steel
- Shock-Blok® plug in head absorbs most of the shock
- Air cushioned, slip resistant grip

Item #	Desc.	Head (oz.)	Length (in.)
VBR999ML	"999" Straight Claw, Milled face	20	16
VBRCF2	California Framer, Milled face	19	16



VAUGHAN & BUSHNELL MFG.

Professional Fiberglass Hammer



- Hollow-core fiberglass handle provides better balance and more effective shock absorption
- Head wedged and epoxy sealed
- Slip-resistant grip

Item #	Desc.	Head (oz.)	Length (in.)
VBFS99	"999" Straight Claw, Smooth face	16	13
VBFS999	"999" Straight Claw, Smooth face	20	14
VBFS999ML	"999" Straight Claw, Milled face	20	16
VBFS505	"999" Straight Claw, Smooth face	24	17
VBFS505M	"999" Straight Claw, Milled face	24	17
VBCF21FG	California Framer, Milled Face	21	16

VAUGHAN & BUSHNELL MFG.

Professional Steel Hammer



- Polished and chromed plated tubular steel handle
- Steel wedged, epoxy-sealed eye
- Slip-resistant grip, contoured for comfort

Item #	Desc.	Head (oz.)	Length (in.)
VB999TML	"999" Straight Claw, Milled face	20	16

VAUGHAN & BUSHNELL MFG.

Professional Titanium Hammer



- TiTech® combines the high speed driving power of Titanium with the versatility of interchangeable steel caps
- Steel caps can be changed from milled face for rough framing to smooth face for finish work
- Exclusive vibration absorbing hollow core design
- High impact overstrike guard
- Slip resistant grip

Item #	Desc.	Head (oz.)	Length (in.)
VBTT1FG	Milled Face, Fiberglass Handle	16	

Replacement Caps

VBRCM-2	Milled Face	-	
---------	-------------	---	--

VAUGHAN & BUSHNELL MFG.

Electrician's Hammer



- Polished striking head, sides and claw
- Extra long poll for striking inside electrical junction boxes
- Hollow core fiberglass handle
- Steel wedged, epoxy-sealed eye
- Slip-resistant grip, contoured for comfort

Item #	Desc.	Head (oz.)	Length (in.)
VBE18F	Straight Claw	18	14

VAUGHAN & BUSHNELL MFG.

Double Face/ Engineer's Hammer



- Fitted with high-impact rubber over strike shields in critical neck area
- Hollow core and slip-resistant, cushioned PVC grip

Item #	Desc.	Head (lbs.)	Length (in.)
VBSD48F	Fiberglass Handle	3	15½

VAUGHAN & BUSHNELL MFG.

Commercial Ball Pein Hammer



- Hardened and tempered to precise standards
- Polished face, bevel & pein
- Other surfaces finished in rust resistant paint
- Compression wedged hickory handle

Item #	Head (oz.)	Length (in.)
VBTC224	24	15¼

VAUGHAN & BUSHNELL MFG.

Commercial Hammer



- Polished striking head, sides and claw
- Good grade hickory handle, triple wedged in tapered eye

Item #	Desc.	Head (oz.)	Length (in.)
VBTC16	Curved Claw	16	13"

VAUGHAN & BUSHNELL MFG.

Solid Rubber Mallet



- Made with specially compounded, quality rubber for high impact strength and long life
- Black head is securely mounted on hickory handle

Item #	Face Dia. (in.)	Length (in.)	Weight (lbs.)	Color
VBRM2B	2¼	10½	1¼	Black
VBRM2W	2¼	10½	1¼	White



VAUGHAN & BUSHNELL MFG.

V5 Construction Hammer



- Wood framing to concrete forms
- Set up or tear down fast and easy
- Double "D" nail holder for one-handed nail starting
- Rip out nails without ripping out forms
- High strength I-beam handle design
- "V" head design reduces shock and vibration

Item #	Desc.	Head (oz.)	Length (in.)
VBV5	Milled Face, Steel Handle	19	17

VAUGHAN & BUSHNELL MFG.

Split-Head Hammer

Titanium



- Anti-vibration pads isolate striking face and claws from handle
- Longneck overstrike plate protects the top grade, American hickory handle
- Exclusive Double D magnetic nail starter is capable of holding either standard or duplex nails
- Face and claws are precision balanced for superior weight distribution
- Patented head design with independent face, claws and handle allows for easy replacement

Item #	Head (oz.)	Length (in.)
VBS2	18	

VAUGHAN & BUSHNELL MFG.

Prospecting Pick



- Forged steel head and I-beam handle, fully polished
- Flat striking face and pointed pick
- Patented, air-cushion grip

Item #	Head (oz.)	Length (in.)
VBAP22	22	13

VAUGHAN & BUSHNELL MFG.

Bear Claw® Scraper Bar



- Wide, thin, sharp blades for scraping and cutting
- Pulling end has rocker head for maximum leverage

Item #	Weight (oz.)	Length (in.)
VBBCSB	11	9¾

VAUGHAN & BUSHNELL MFG.

Bear Claw® Nail Pullers



- Forged, tempered steel with flat claw for easy wedging and minimal wood damage
- Rocker head provides excellent leverage
- Black, rust-resistant finish

Item #	Weight (oz.)	Length (in.)
VBBC8	11	7¾
VBBC9	12½	9½
VBBC10	13½	10½
VBBC12	18½	11¾
VBBC14	12¾	14¼

VAUGHAN & BUSHNELL MFG.

Superbar® Prybar



- "Shepherds Crook" rocker head design for maximum prying power
- Forged, spring tempered steel
- Three beveled nail slots
- Polished sharp blades for easy insertion

Item #	Weight (oz.)	Length (in.)
VBB215	24	15
VBB215L	32	21

VAUGHAN & BUSHNELL MFG.

Mini-Bar® Pry Bar



- Versatile little tool will open paint cans and pull small nails and staples
- High quality steel, chrome plated

Item #	Weight (oz.)	Length (in.)
VB222	1	5½

VAUGHAN & BUSHNELL MFG.

Ripping Bar



- Forged of tough, ¾" hex, high carbon steel
- Three beveled nail slots
- Hardened and tempered claws
- Blue, rust-resistant finish, polished ends

Item #	Weight (oz.)	Length (in.)
VBRB18	40	18



VAUGHAN & BUSHNELL MFG.

Wrecking Bar

- Drop forged, heat treated hex steel stock
- Rocker head design for increased leverage
- Two angles for varying torque
- Blue rust-resistant finish



Item #	Length (in.)
VB57736	36
VB57748	48

VAUGHAN & BUSHNELL MFG.

Nail Pullers

- Designed for extracting deeply imbedded nails, these pullers are forged of 5/8" hex, high carbon steel
- Polished claws hardened and tempered for strength
- Blue, rust-resistant finish



Item #	Style	Weight (oz.)	Length (in.)
VBNP12DE	Double end	16	11
VBNP12G	Single end, Cushion grip	20	11½
VBNP15CE	Chisel end	22	15

VAUGHAN & BUSHNELL MFG.

Bricklayer's Sets

- Drop forged of high carbon steel, then hardened and tempered
- Beveled striking face minimizes mushrooming and chipping
- Ground smooth, with rust-resistant black finish



Item #	Blade Width (in.)	Length (in.)
VB4	4	7



STANLEY INDUSTRIAL TOOLS

Pry Bar

"Wonder Bar"

- Heat treated for extra toughness with polished and beveled cutting edges
- Contoured carbon steel bar is ideal for pulling nails, prying, lifting, scraping
- Beveled nail slot both ends
- 1-3/4" wide x 12-3/8" long



Item #
ST55-515

STANLEY INDUSTRIAL TOOLS

Utility Bar

FuBar™

- The ultimate multi-purpose demolition tool
- Excellent for prying, splitting, board bending & heavy striking jobs
- Sledge hammer face
- Ripping hook
- Textured grip for excellent control and comfort
- Nail puller & pry bar



Item #	Length (in.)
ST55-099	18
ST55-120	30



APEX

Indexing Pry Bar

GEARWRENCH®



Item #	Length (in.)
GW82210	10
GW82216	16

APEX

Extendable Pry Bar

GEARWRENCH®



Item #	Length (in.)
GW82220	18-29
GW82248	29-48



STANLEY INDUSTRIAL TOOLS

Hammer Tacker

Heavy-Duty

- Contractor quality design, heavy-duty steel construction
- Full rubber grip to absorb shock and protect user's hands



Item #
STPHT250C



ARROW FASTENER COMPANY,
INC.

Heavy-Duty Hammer Tacker



- All steel construction
- High carbon hardened steel working parts
- Jam resistant mechanisms
- Precision locked rear loading
- Retractable striking edge
- Specially designed power grip handles
- Durable chrome finish
- Works with T50™ staples

Item #
AWHT50A

ARROW FASTENER COMPANY,
INC.

Multipurpose Wire Tacker



- All steel construction
- Grooved driving blade
- Jam resistant mechanism
- Short span easy compression handle
- Chrome finish resists wear and tear
- Grooved guide ensures consistent stapling
- For low voltage wire up to 1/4" diameter
- Works with T25™ staples

Item #
AWT25M

ARROW FASTENER COMPANY, INC.
Heavy-Duty Tacker Gun



- All steel construction
- Jam resistant mechanism
- Hardened steel working parts
- Easy squeeze double leverage operation
- Visual staple refill window
- Works with T50® staples

Item #
AWT50M

ARROW FASTENER COMPANY,
INC.

8000 PowerShot Pro Staple & Nail Gun



- Forward action design eliminates stapler "kickback"
- Capable of rapid fire
- One hand operation
- Anti-slip comfort grip
- Staples/nails remaining window
- Fires 1/4" thru 9/16" heavy-duty PowerShot and Arrow T50 staples and 9/16" PowerShot brad nails, drives staples flush and includes wire guide attachment

Item #
AW8000



STANLEY INDUSTRIAL TOOLS

Brad/Nail Staple Gun

Heavy-Duty



- Easy-squeeze product works overtime as a staple gun, brad nailer, cable tacker and wire tacker
- Uses Stanley® SharpShooter® TRA700 series or Arrow® T-50® heavy-duty narrow crown staples and 1/2", 9/16" and 5/8" Brads

Item #
STTR250

STANLEY INDUSTRIAL TOOLS

Heavy-Duty Crown Staples

- Heavy-duty - narrow crown - fits TR100, TR200, TRE500 series, PHT150, PHT250 and Arrow® T-50
- Box of 1,000



Item #	Size (in.)
STTRA704T	1/4
STTRA705T	5/16
STTRA706T	3/8
STTRA708T	1/2
STTRA709T	9/16

STANLEY

STANLEY INDUSTRIAL TOOLS

Cable Staples

- For low voltage wires
- Galvanized to reduce corrosion
- Fits Arrow® T-25 and Stanley® CT10C series
- 1,000 Units

Item #	Size (in.)
STCT109T	3/16



APEX

APEX

Soldering Gun Kit

Weller®

- Professional heavy-duty gun
- Dual-heat gun produces 260 or 200 watts
- Pistol grip design, ready to use in 6 seconds
- Fingertip trigger selects high (1st trigger position), or low output (2nd trigger position)
- Heavy gauge, high efficiency, tin-plated copper tip
- Twin lights illuminate work
- Contents: D550 soldering gun, 1 each soldering, smoothing, cutting tips, coil of lead free solder and instruction book
- 2-wire cord, UL and cUL listed



Item #
CGD550PK

APEX

Replacement Tips for Soldering Gun

Weller®

- Tips are compatible with Weller® soldering guns
- All tips are made of copper

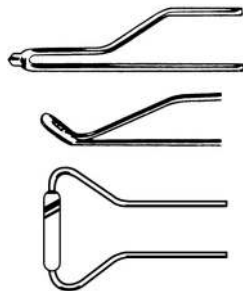

Item #	Desc.	Type
CG6130	Tip With Hex Nut	Cutting
CG6150	Tip Only	Cutting
CG6140	Tip With Hex Nut	Smoothing
CG6160	Tip Only	Smoothing
CG7250W	Tip Only- Per Bag	Standard
CG7250N	Tip With Hex Nut	Standard
CGRCT	Tip Only	Rope Cutting

MARSON

MARSON

HP-2 Hand Riveter

- Precision die cast, high strength aluminum alloy body; drop forged carbon steel upper handle; and thick cushion-molded vinyl grips for comfort
- Sets up to 3/16" steel rivets and comes with four mounted nose-pieces (3/32", 1/8", 5/32", and 3/16") and a service wrench
- MV39001 Kit includes: 200 assorted Klik-Fast rivets in popular sizes plastic case houses and protects the tool, rivets and optional countersink double ended drill bit



Item #	Desc.	Rivet Dia. Cap.	# of Nose-pieces	Range
MV39000	Tool Only	3/16	4	3/8, 1/8, 5/8, 5/32, 3/16
MV39001	Kit	3/16	4	3/8, 1/8, 5/8, 5/32, 3/16

APEX

APEX

Rebar Cutter/Bender

H.K. Porter®

- Mounts easily on most flat surfaces to enhance leverage and increase safety
- Cuts and bends to 90° or 180°
- Length: 52"
- Handle Material: Tubular Steel
- Max. Capacity: 5/8"
- Shear-cut blades



Item #
CG0590RBJ

APEX

Cable Cutter

H.K. Porter®

- For wire rope to 3/4"
- Notched, shear-cut blades hold and lock cable in cutting position
- Cuts steel cable, coarse- or fine-stranded cable, or wire rope with minimal distortion



Item #
CG0190MTN



APEX

APEX Bolt Cutter

H.K. Porter®



- General plant maintenance tool
- Drop-forged, precision ground, alloy tool steel jaws with center-cut blades
- Cuts soft, medium, or hard materials
- Maximum hardness of material to be cut: Brinell 455/Rockwell C48

Item #	Length (in.)	Soft Metal Cut Dia. (in.)	Hard Metal Cut Dia. (in.)
--------	--------------	---------------------------	---------------------------

CG1490MC	14	5/16	3/16
CG0090MC	18	3/8	1/4

Cutterhead Replacement For:

CG0190MC	24	7/16	5/16
CG0290MC	30	1/2	3/8
CG0390MC	36	9/16	7/16
CG0590MC	42	1 1/16	1/2

APEX Wire Rope & Cable Cutter

H.K. Porter®



- Excellent cutter for 3/16" hard - 1/4" soft wire rope or cable, piano wire or aircraft cable
- Length: 7-1/2"
- Cable Capacity: 3/16"
- Rod Capacity: 3/32"

Item #
CG0690TN

APEX Replacement Jaws For Bolt Cutter

H.K. Porter®



- Replacement jaw
- One pair

Item #	Parts For
--------	-----------

Center Cut

CG1412C	1490MC
CG0012C	0090MC

Clipper Cut

CG0112C	0190MC
---------	--------

WILTON

WMH TOOL GROUP

Utility Vise

Wilton



- 180° swivel base with lockdown allows for quick and easy positioning
- Powder coat paint resists scratches and provides a tough durable surface
- Built-in pipe jaws handle various pipe sizes
- Large anvil work surface
- Perfect for general clamping applications

Item #	Model	Jaw Width (in.)	Jaw Opening (in.)	Throat Depth (in.)
--------	-------	-----------------	-------------------	--------------------

JE11127	675	5 1/2	5	3 1/4
JE11128	676	6 1/2	5 1/2	3 13/16

WMH TOOL GROUP

Mechanics Vise

Wilton



- Swivel base rotates 360° and has double lockdowns ensuring maximum stability
- Powder coat paint resists scratches and provides a tough durable finish
- Replaceable hardened steel top and pipe jaws
- Large anvil work surface

Item #	Model	Jaw Width (in.)	Jaw Opening (in.)	Throat Depth (in.)
--------	-------	-----------------	-------------------	--------------------

JE21400	745	5	5 1/4	3 3/4
JE21500	746	6	5 3/4	4 1/8

WMH TOOL GROUP

Tradesman Vise

Wilton



- 360° swivel base with double lockdowns
- Wider jaws provide greater clamping surface
- Fully enclosed spindle and nut increases the life of the vise
- Large anvil work surface
- Precision turned sidebar

Item #	Model	Jaw Width (in.)	Jaw Opening (in.)	Throat Depth (in.)
--------	-------	-----------------	-------------------	--------------------

JE63200	1755	5 1/2	5	3 3/4
JE63201	1765	6 1/2	4	



WMH TOOL GROUP

Carriage C-Clamps

Wilton



- Frames made from high strength ductile iron castings
- Sliding pin (vise type) handle, single acme thread rolled spindle and oscillating ball and socket tip

Item #	Model No.	Capacity (in.)	Throat Depth (in.)	Spindle Dia.(in.)	Clamp Pressure (lbs.)
JE22005	540A-6	0-6	2¾	⅝	2450
JE22006	540a-8	0-8	3¾	¾	2750

UnionTools

UNION TOOLS

Wedge Point Bar

Straight Pattern

- Best for levering and demolition jobs
- Forged carbon steel
- 2-1/4" x 1-1/4" blade
- 60" overall length
- Wt: 18 lbs.



Item #
UF30-658

UNION TOOLS

Pinch Point Bars

Straight Pattern

- Best for levering and demolition jobs
- Forged carbon steel



Item #	Blade Sz. (in.)	OA Length (in.)	Weight (lbs.)
UF30-646	2¼ x 1	48	10
UF30-648	2¼ x 1	51	12
UF30-650	2¼ x 1¼	60	18

UNION TOOLS

San Angelo Bars

- Best for clearing rocks and roots from postholes and ditches
- Forged carbon steel
- Straight pattern 2-1/2" x 2" blade



Item #	OA Length (in.)	Weight (lbs.)
UF30-664	60	14
UF30-666	72	17

UNION TOOLS

Tamping Bar

- Best for clearing rocks and roots from postholes and ditches
- Forged carbon steel

Item #	Blade Size (in.)	O/A Length (in.)	Weight (lbs.)
UF30-670	9½ x 2	72	17



UNION TOOLS

Wrecking Bars

- Best for demolition jobs and pulling nails and spikes
- Doubles as crowbar or wedge
- Gooseneck pattern

Item #	Bar Size (in.)	Weight (lbs.)
UF30-636	30 x ¾	4¼
UF30-640	48 x 1	12



UNION TOOLS

Post Hole Digger

- For digging post holes and footings in all soil types
- Hercules pattern, two piece, riveted, high carbon steel blades with 6" point spread and beveled digging edge
- 48" Hardwood handles

Item #
UF78-005



UNION

Concrete Rake

With Rebar Hook

Razorback®

- Best for spreading and leveling concrete
- Industrial grade tempered steel blade
- 60" premium Northern White Ash handle
- 20" x 4" blade, steel socket nailed to 60" handle

Item #
UF83-154





UNION TOOLS
Mortar Mixer Hoe
Razorback®

- Best for mixing mortar, concrete, plaster and spackling
- 9" x 6" perforated, forged blade for better mixing
- 66" premium Northern White Ash handle
- 5/8" gooseneck shank for added strength
- 8" tube with cap prevents debris build up



Item #
UF66-158



UNION TOOLS
Pulaski Axe

- For chopping and splitting wood
- Drop-forged, tempered carbon steel head
- 36" lacquered Hickory handle for strength
- Wt: 3-1/2 lbs.



Item #
UF30-362

UNION TOOLS
Railroad Pick

- For breaking up hard, rocky soil
- 5 lb. forged steel head, 21" length, 1-7/16" width
- 36" hardwood handle with overstrike protection



Item #	Desc.
UF30-127	Head and Handle
UF30-138	Head Only
UF20-164	Handle Only

UNION TOOLS
Pick Mattock
Razorback®

- Best for cutting roots and breaking up soil
- 5 lb. forged head, 19-1/4" length, 3-1/2" width
- 36" hardwood handle with overstrike protection



Item #	Desc.
UF30-125	Head and Handle
UF30-134	Head Only
UF20-164	Handle Only

UNION TOOLS
Bow Rake

- Good for preparing garden soil
- Welded head with 14 teeth
- 54" White Ash handle w/steel ferrule for strength
- 13-3/4" x 2-3/4" head, 3/16" thick



Item #
UF63-107

UNION TOOLS
Bow Rake
Razorback®

- For loosening and leveling mulch, peat moss and loose or heavy soils
- 15-tine, 16" x 3-1/4" one piece forged steel head
- 60" ash wood handle



Item #
UF63-141

UNION TOOLS
Aluminum Landscape Rake
Razorback®

- For spreading dirt, gravel and sand
- 36" Heavy-duty aluminum head with bolted braces
- 66" Powder-coated Aluminum handle with 5-1/2" end grip



Item #
UF63-000

UNION TOOLSLAWN & LEAF
RAKES

- Good for removing matted thatch, wet grass, debris
- Steel tines for thatching
- Wood handle
- Heavy coil steel spring brace



Item #	Tines	Length (in.)	Handle
UF64-430	22	48	Tap-in
UF64-582	24	54	Bolt thru

UNION TOOLS

Asphalt Lute Rake

- For spreading and leveling asphalt and tar
- 36" heavy-duty aluminum head with wrap-around bolted braces
- 82" powdered-coated aluminum handle with 5-1/2" end grip



Item #
UF63-133

UNION TOOLS

Road/Stone Rake

Razorback®

- For spreading and leveling gravel
- 16-tine 17-3/4" x 4" one piece forged head
- 66" Ash wood handle



Item #
UF63-122

UNION TOOLS

Floor Scraper

Razorback®

- For scraping hard surfaces, form cleaning, tile removal and general construction
- 14" x 6" flexible welded spring steel blade
- 60" wood handle



Item #
UF24-516

UNION TOOLS

Sidewalk/Ice Scraper

Razorback®

- Professional grade forged construction for heavy-duty use
- Socket pattern
- 7" x 6" industrial gauge, forged blade
- 54" Ash wood handle



Item #
UF78-202

UNION TOOLS

Irrigation Shovel

- Ideal for clearing irrigation ditches
- Rolled step prevents material build-up
- #2 blade size
- 9-1/4" x 11-1/2" open-back blade
- 24" handle lift
- 9" socket
- 48" Ash wood handle



Item #
UF40-107

UNION TOOLS

Roof Ripper

Razorback®

- Notched edge shovel for removing shingles
- Turned step, 9" socket
- 7-3/8" x 12" blade
- Welded fulcrum for leverage
- 48" ash wood handle



Item #
UF46-141

UNION TOOLS

Round Point Shovel

Razorback®

- For digging and excavation in hard, rocky soil
- Forward turned step
- #2, 9-1/2" x 12" blade
- Dual rivet, extended tab socket
- 48" Ash wood handle



Item #	Desc.
UF45-520	Open Back
UF45-657	Closed Back

UNION TOOLS

Round Point Shovel

- Forward turned step
- 16 gauge, #2 open back blade with Dura-Torque crimp collar
- 9" x 11-1/2", 9" socket
- 48" Fiberglass handle



Item #
UF45-160

UNION TOOLS

Round Point Shovel

- Good for digging in sandy, light soils
- Forward turned step
- 16 gauge, open back blade
- 9-1/4" x 11-1/2", 9" socket
- 48" Ash wood handle



Item #
UF40-191



UNION TOOLS

Round Point Shovel

- For digging and excavation in most soil types
- Forward turned step
- 16 gauge, #2 open back blade with Dura-Torque crimp collar
- 9" x 11-1/2", 9" socket
- 48" Ash wood handle



Item #

UF45-106

UnionTools

UNION TOOLS

Round Point Shovel

- For digging in tight spaces and transplanting
- Forward turned step
- #0 8-1/4" x 6" open back blade, 7" socket
- 43" Ash wood handle



Item #

UF41-126

UNION TOOLS

Round Point Shovel

Razorback®

- For digging and excavation in hard, rocky soils
- Forward turned step
- 14 gauge, #2, 9-1/2"x12" open back blade w/ reinforced steel backbone
- 48" Fiberglass handle



Item #

UF45-000

UNION TOOLS

Square Point Shovel

Razor-Back®

- For transferring heavy, loose soil
- Forward turned step
- 14 gauge, #2 size, 9-1/2" x 12" industrial gauge blade
- 48" Ash wood handle
- Dual rivets, extended tab socket



Item #	Desc.
UF44-124	Open back
UF44-363	Closed back

UNION TOOLS

Square Point Shovel

- Best for transferring clay, heavy or rocky materials
- Forward turned step
- 16 gauge, #2, 9-1/4" x 11-1/2" open back heavy-duty blade, 9" socket
- Dura-Torque crimp collar
- 48" Fiberglass handle



Item #

UF45-161

UNION TOOLS

Square Point Shovel

- Good for transferring sandy, light soils
- Forward turned step
- 16 gauge, #2, 9-1/4" x 11-1/2" open back blade, 9" socket
- 48" Ash handle



Item #

UF40-184

UNION TOOLS

Square Point Shovel

- For transferring rocky & drier soils
- Forward turned step
- #2 open back, heavy-duty blade w/Dura-Torque crimp collar
- 9-1/4" x 11-1/2" blade, 9" socket
- 48" Ash wood handle



Item #

UF44-106

UNION TOOLS

Square Point Shovel

Razorback®

- For transferring heavy, rocky materials
- Rolled step
- 14 gauge, #2 open back blade
- 9-1/2" x 12", 10" socket
- 48" Fiberglass handle with cushion end grip



Item #

UF44-000

UNION TOOLS

Trench/Clean Out Shovels

Razorback®

- For cleaning out trenches
- Industrial grade steel blade with 11" socket
- Forward turned step
- 48" Ash wood handle



Item #	Desc.
UF47-023	3" Blue blade

Item #	Desc.
UF47-024	4" Orange blade

UNION TOOLS

Trenching Shovel



Razorback®

- Ideal for digging/cleaning narrow trenches
- Rolled step prevents debris build-up
- 14 gauge, 4" x 11-1/2" blade, 9" socket
- Dura-Torque crimp collar
- 54" Fiberglass handle

Item #
UF47-138

UnionTools®

UNION TOOLS

Western Aluminum Grain Scoop

- Good for handling grain, sand, snow and other loose materials or general purpose clean-up
- 29" Ash wood handle with poly D-grip



Item #	Size	Blade Size (in.)
UF53-102	#12	14¾x18¾
UF53-103	#10	14¾x17¾

UNION TOOLS

Poly Grain/Snow Scoop

- Ideal for scooping grain, snow, mulch or general purpose cleanup
- #12 ABS 14-3/4" x 18-3/4" blade
- 29" Ash wood handle with poly D-grip



Item #
UF79-770

UNION TOOLS

Western Aluminum Scoop Shovel

Razorback®

- For transferring grain, snow and loose materials
- #10 Sized 14-1/2" x 17-3/4" industrial gauge aluminum blade
- 48" Ash wood handle



Item #
UF53-127

UNION TOOLS

Double Milled Sledge Hammers

- For heavy pounding jobs
- 16" Fiberglass handle w/grip



Item #	Desc.
UF12-156	6 lb. Head
UF12-157	8 lb. Head

UNION TOOLS

Drilling Hammers

- For driving drilling bits and heavy chisels
- Forged steel head with chamfered edges
- 10-1/2" Hickory handle



Item #	Head Weight (lbs.)	Head Length (in.)
UF30-567	2	4
UF30-568	3	4¼

UNION TOOLS

Sledge Hammers

Double Milled Head

- Best for heavy pounding jobs
- Forged double milled steel head for added durability
- 36" lacquered Hickory handle for strength



Item #	Head Weight (lbs.)	Head Length (in.)
UF30-578	4	5½
UF30-580	8	6½
UF30-582	10	6¾
UF30-584	12	7

UNION TOOLS

Engineer's Hammers

- Best for driving stakes and rods
- Forged steel head w/chamfered edges for added durability
- 16" handle



Item #	Handle	Head Weight (lbs.)	Head Length (in.)
UF30-576	Hickory	4	4¼
UF30-592	Fiberglass	4	4¾



UNION TOOLS

Sledge Hammers

Razor-Back®



- For heavy pounding jobs
- Forged, steel head with chamfered edges for added durability
- 36" Fiberglass handle for superior strength

Item #	Head Weight (lbs.)	Head Length (in.)
UF30-596	8	6¼
UF30-598	10	7



STANLEY INDUSTRIAL TOOLS

Ball Pein Hammer



- High carbon steel forged heads, hardened and tempered
- Rim Tempered™ face minimizes chipping, assures greater safety
- Polished face, poll, and peen
- Hickory handle

Item #	Wt. (oz.)	OA Lgth. (in.)
ST54-016	16	14
ST54-024	24	15
ST54-032	32	16



STANLEY INDUSTRIAL TOOLS

Dead Blow Hammer

Compo-Cast® Soft Face



- Non-sparking, non-marring soft face of Uni-Cast™ construction has no exposed metal
- Dead blow function uses steel shot
- Hi-Vis orange

Item #	Wt. (oz.)	Overall Lgth. (in.)
ST57-532	21	12¾
ST57-533	42	14¼
ST57-534	52	15¼



NUPLA CORPORATION

Dead Blow Hammer



Fiberglass

- Smart hammer technology for creating the ultimate dead blow effect
- Non-marring face

Item #	Head Weight (lbs.)	Handle Length (in.)	Grip
NU10-035	3	14½	SG

NUPLA CORPORATION

Ball Pein Hammers



Fiberglass

- Carbon steel heads
- Precision forged and heat treated



Item #	Head Weight (oz.)	Handle Length (in.)	Grip
NU21-008	8	11	H
NU21-012	12	H	
NU21-017	16	13	SG
NU21-020	20	13	H
NU21-024	24	14	H
NU21-025	24	14	SG
NU21-033	32	14	SG

NUPLA CORPORATION

Cross Pein Hammers



Fiberglass

- Classic blacksmith style
- Carbon steel forged heads

Item #	Head Weight (lbs.)	Handle Length (in.)	Grip
NU29-020	2	14	C
NU29-030	3	14	C

NUPLA CORPORATION

Double-Faced Sledge Hammers



Fiberglass

- Classic blacksmith sledge
- Carbon steel forged heads

Item #	Head Weight (lbs.)	Handle Length (in.)	Grip
NU27-101	10	32	SG

NUPLA CORPORATION
Double-Faced Sledge Hammers



Ergo Power - Fiberglass

- Injection molded cover protects fiberglass from over strikes
- Carbon steel forged heads

Item #	Head Weight (lbs.)	Handle Length (in.)	Grip
NU27-808	8	32	SG
NU27-810	10	32	SG
NU27-812	12	32	SG
NU27-816	16	32	CS

NUPLA CORPORATION
Rubber Mallet



Fiberglass

- 2 lb. rubber head

Item #	Head Weight (lbs.)	Handle Length (in.)	Grip
NU13-120	2	16	H

NUPLA CORPORATION
Brass Hammers



Fiberglass

- Non-sparking brass head

Item #	Head Weight (lbs.)	Handle Length (in.)	Grip
NU30-025	2½	12	SG
NU30-040	4	12	SG



WMH TOOL GROUP
Sledge Hammer
Wilton®



- Unbreakable handle is made with tempered steel and surrounded by heavy-duty molded rubber
- Ergonomic handle absorbs shock, ensures comfort and has a slip-resistant grip
- High-visibility head

Item #	Head Wt. (lbs.)	Handle Lgth. (in.)
WT19999	2½	12
WT20000	4	12
WT20015	6	30
WT20020	10	30
WT20025	12	30
WT20003	14	30

WMH TOOL GROUP
Ball Pein Hammer
Wilton®



- Unbreakable handle is made with tempered steel and surrounded by heavy-duty molded rubber
- Ergonomic handle absorbs shock, ensures comfort and has a slip-resistant grip
- High-visibility head

Item #	Head Wt. (oz.)	Handle Lgth. (in.)
WT20030	24	14
WT20035	32	14



NUPLA CORPORATION
Classic Aluminum Scoop



Fiberglass

- #10 aluminum blade

Item #	Gauge	Blade Dim. (in.)	Handle Length (in.)	Grip
NU69-010	11	14½ x 17¾	27	D

NUPLA CORPORATION
Classic Western Scoop
Fiberglass



- Hollow back blade

Item #	Gauge	Blade Dim. (in.)	Handle Length (in.)	Grip
NU69-109	16	14 x 17	27	D

NUPLA CORPORATION
Classic Round Point Shovels



Fiberglass

- 9" x 11-1/2" blade
- 16 Gauge

Item #	Size	Blade Style	Handle Length (in.)	Grip
NU69-027	#2	Hollow Back	27	D
NU69-048	#2	Hollow Back	48	Butt
NU69-150	#0	Hollow Back	48	Butt



NUPLA CORPORATION
**Classic Square Point
Shovels**



Fiberglass

- 9-7/8" x 11-1/2" blade
- 16 Gauge

Item #	Size	Blade Style	Handle Length (in.)	Grip
NU69-127	#2	Hollow Back	27	D
NU69-148	#2	Hollow Back	48	Butt

NUPLA CORPORATION
Power Pylon Shovels



Fiberglass

- HD14 Gauge
- Solid back blade style
- Ergo Power, 48" handle

Item #	Desc.	Blade Dim. (in.)	Grip
NU72-145	Square Point	9 7/8 x 11 1/2	Ergo
NU72-245	Round Point	9 x 11 1/2	Ergo

NUPLA CORPORATION
**Power Pylon
Trenching Shovel**



Fiberglass

- HD 14 gauge
- Solid-back blade style
- 4-1/2" x 12" blade
- Ergo Power, 48" handle

Item #
NU69-223



NUPLA CORPORATION
Classic Drain Spades



Fiberglass

- "Sharp Shooters"
- 16 gauge
- Hollow back blade style

Item #	Blade Dim. (in.)	Handle Length (in.)	Grip
NU69-276	4 3/4 x 16	27	D
NU69-277	4 3/4 x 14	48	Butt

NUPLA CORPORATION
**Roofers Ripping
Spade**



Fiberglass

- 14 gauge
- Hollow back blade style
- 6-7/8" x 11-1/2" serrated blade
- Butt grip 48" handle

Item #
NU69-799

NUPLA CORPORATION
**Classic Post Hole
Digger**



Fiberglass

- 14 gauge
- Closed back blade style, 6-1/2" dia.
- 48" handle

Item #
NU69-548

NUPLA CORPORATION
Classic Bow Rake



Fiberglass

- Steel 16 tine head
- 16-1/4" W head, 60" handle

Item #
NU69-616

NUPLA CORPORATION
Concrete Placer



Fiberglass

- 20" Blade with hook
- Pro Tec 54" handle

Item #
NU79-314

NUPLA CORPORATION
Soil Probe



Fiberglass

- With metal tip
- Classic T-handle

Item #	Length (in.)
NU69-401	48
NU69-403	60

Replacement Tip for Probes
NU12-495 -

NUPLA CORPORATION
Classic Digging Bar



Fiberglass

- 6' bar with point and ball

Item #
NU69-351

NUPLA CORPORATION
Fire Swatter



- Specialty fire tool
- Butt grip 60" handle

Item #
NU69-215

NUPLA CORPORATION
Nuplabond Epoxy

- For replacement handles
- Size 12 gr.



Item #
NU39-012



NUPLA CORPORATION
Replacement Tool Handles
Fiberglass

- Replacement handles for various applications



Item #	Desc.
NU55-551	Pick/Mattock Handle, #6 eyehole, 36" handle, SG grip
NU59-801	For Sledge 6-16 lbs. Mech/Loc® 36" Handle, SG grip
NU59-987	For Sledge and Cross Pein 14" Handle, SG grip
NU68-446	Fits Hollow/Closed Back Shovels, 48" D Handle
NU68-448	Fits Hollow/Closed Back Shovels, 48"
NU68-555	Fits Broom/Mop, 60"

NUPLA CORPORATION
Replacement Shovel
Blade



- Heavy gauge round point power pylon shovel blade

Item #
NU69-001

STANLEY

STANLEY INDUSTRIAL TOOLS
Plumb Bob



- Polished-lacquer, solid-brass construction is durable and rust resistant
- Replaceable, hardened steel tip is long-lasting
- Screw top simplifies attaching string to center of plumb
- 8 oz. with extra tip

Item #
ST47-973

STANLEY INDUSTRIAL TOOLS

Chisel Set
FatMax®



- 3 pc. set with 1/2", 3/4" and 1" widths, 9" long
- Hardened, tempered high-chrome carbon alloy steel blade for edge retention

Item #
ST16-970

STANLEY INDUSTRIAL TOOLS

Wood Chisels



FatMax®

- Hardened, tempered high-chrome carbon alloy steel blade for edge retention
- Overall Length: 9"

Item #	Size (in.)
ST16-975	1/2
ST16-977	3/4
ST16-978	1

STANLEY INDUSTRIAL TOOLS

Jab Saw



Fat Max™

- Sharp Tooth™ technology cuts 50% faster than traditional tooth designs
- Cuts on both the push and pull stroke

Item #
ST20-556



STANLEY INDUSTRIAL TOOLS

Wallboard Saw

- Designed especially for making cuts in plasterboard
- Self-starting point sharpened for plunge cuts
- 6" pointed blade



Item #

ST15-206

STANLEY INDUSTRIAL TOOLS

Hand Saw

FatMax®

- SharpTooth™ Saw Technology uses three cutting surfaces to cut 50% faster
- Induction-hardened teeth stay sharp up to five times longer than standard teeth-15" x 9 pt. blade
- Back of saw can be used to mark 45° and 90° angles



Item #

ST20-045

STANLEY INDUSTRIAL TOOLS

Hand Saw

Sharptooth™

- Multi-purpose saw for a high-quality finish
- For use on laminate, plastic pipe, and all wood types
- SharpTooth™ saw technology uses three cutting surfaces to cut 50% faster
- 26" x 12 pt. blade



Item #

ST20-065



DBI/SALA

Construction Style Harness

ExoFit NEX™

- Duo-Lok™...lightweight, one-handed use w/ memory-fit
- Revolver™...simple and fast adjustment that locks into position
- Tech-Lite™ Aluminum d-rings:...lightweight alloy adds to comfort
- Repel Technology Webbing...provides up to 5 times more abrasion resistance and water repellency
- Integrated Trauma Straps
- Reflective material provides better visibility
- Impact indicator stitches
- Breakaway lanyard keepers
- Sewn-in hip pad / belt for comfort during a long work day
- Max capacity of 420lbs (including weight of person(s) and gear)



Item #	Size
DI1113121	Small
DI1113124	Medium
DI1113127	Large

DBI/SALA

Tower Climbing Harnesses

ExoFit NEX™

- Duo-Lok™: Lightweight one-handed use w/memory-fit
- Revolver™: Simple and fast adjustment that locks into position
- Tech-Lite™ Aluminum d-rings: Lightweight alloy adds to comfort
- Repel Technology Webbing: Provides up to 5 times more abrasion resistance and water repellency
- Integrated Trauma Straps
- Reflective material: Provides better visibility
- Impact Indicator Stitches
- Breakaway lanyard keepers
- Max Capacity 420lbs
- Meets or exceeds all applicable industry standards including OSHA and ANSI including the stringent ANSI Z359



Item #	Size
DI1113190	Small
DI1113191	Medium
DI1113192	Large

DBI/SALA

Construction Vest Style Harness

ExoFit™

- The ExoFit™ design is based on the concept of a single piece of material constructed in the shape of an "X" that wraps around you for the ultimate in no-tangle donning and comfortable security
- With back D-rings, sewn-in back pad and belt with side D-rings, quick-connect buckles



Item #	Size
DI1108500	Small
DI1108501	Medium
DI1108502	Large
DI1108507	Extra Large

DBI/SALA

Tower Climbing Harness

ExoFit™

- ExoFit™ tower climbing vest-style full body harness with front, back and side D-rings, belt with sewn-in back pad, removable seat sling and quick-connect buckle leg straps
- The ExoFit™ design is based on the concept of a single piece of material constructed in the shape of an "X" that wraps around you for the ultimate in no-tangle donning and comfortable security
- The materials are soft and lightweight, yet extremely durable; the shoulder, hip and leg padding is built-in so it can't slip; with breathable 3-D mesh lining



Item #	Size
DI1108652	Large

DBI/SALA

Vest-Style Harness

ExoFit™

- Cushioned shoulder pads keep the pressure off all the time; in a fall, they absorb shock and help distribute your weight, they are built-in so they can't slip or slide off your shoulder
- Strap keepers prevent dangerous entanglements
- Soft, light-weight webbing is strong without feeling stiff or coarse; the straps are easy to adjust and always hold their adjustment
- Aerospace™ Dri-lex® lining immediately draws moisture away
- Three quick-connect buckles offer one-handed operation and smooth adjustment
- Torso buckles adjust easily, yet hold straps firmly in place and complete the 5-point adjustment system
- The cushioned leg and hip straps and soft seat strap offer comfort and additional security during a fall
- Anti-tear, abrasion-resistant ballistic nylon for rugged strength and durability
- Back D-ring of forged alloy steel (5,000 lbs. minimum tensile strength)
- Black D-ring, loops for belt, quick connect buckles



Item #	Size
DI1107976	Medium
DI1107977	Large
DI1107981	XLarge



DBI/SALA
Vest Style Harness
Delta No-Tangle™

- Delta No-Tangle™ design for added comfort and easy donning
- Spring loaded stand-up back D-ring ensures fast, easy, and safe connections
- Adjustable non-slip chest strap with easy to use pass-thru buckle
- Parachute buckles on lower shoulder straps for quick and easy adjustment
- Tongue buckle leg straps for fast & easy donning
- Polyester webbing construction for added durability; plated hardware for corrosion resistance
- The 1102008 is the same except includes side D-rings



Item #	Size
DI1101252	XLarge
DI1102000	Universal
DI1102008	Universal

DBI/SALA
Construction Cross-Over Harness
Delta No-Tangle™

- With added back support and tool-carrying options
- Pass-thru buckle leg straps
- Adjustable front D-ring; back D-ring; body belt with foam back pad and side D-rings
- Application: Fall arrest (FA), work positioning (WP), restraint (RT)



Item #	Size	Waist Measurement (in.)
DI1101810	Medium	36 - 44
DI1101811	Large	40 - 48
DI1101812	X Large	44 - 52

DBI/SALA
Cross-Over Style Harness
Delta No-Tangle™

Durable harness, constructed of polyester webbing, is designed to restrain the worker in the event of a fall. Complete with front and side D-rings for ladder climbing and positioning and a back D-ring for fall protection. Delta "no tangle" back pad helps harness keep it shape and makes it easier to put on and adjust.



Other features include:

- Parachute adjuster buckle on upper shoulder strap; pass thru adjuster buckles on lower shoulder and leg straps
- *The 1102010 is the same as the 1103270 except no side D-rings.

Item #	Desc.	Size
DI1103270	4 D-Ring	Universal
DI1102010	2 D-Ring	Universal

DBI/SALA
Vest Style Harness
Delta No-Tangle™

- Polyester webbing resists abrasion and UV and chemical degradation
- Web keepers at all adjustment points hold extra webbing so it is tucked away and out of your way
- Seat slings provide both comfort and even distribution of fall arrest forces
- Adjustable non-slip chest strap moves when you want it to; stays put when it should. Metal pass-thru buckle delivers added strength and safety
- Built-in loops for a body belt allow you to customize the harness with your own belt and the harness will support it
- Cadmium-plated forged alloy steel hardware precisely engineered for maximum strength, durability and reliability. 5000 lbs. tensile strength



Item #	Size
DI1102001	Universal

DBI/SALA
Vest Style Harness
Delta No-Tangle™

- Polyester webbing resists abrasion and UV and chemical degradation
- Compare our stitching and precise stitch patterns to anyone else; we sew in strength you can trust
- Web keepers at all adjustment points hold extra webbing so it is tucked away and out of your way
- Seat slings provide both comfort and even distribution of fall arrest forces
- Adjustable non-slip chest strap moves when you want it to; stays put when it should
- Metal pass-thru buckle delivers added strength and safety
- Built-in loops for a body belt allow you to customize the harness with your own belt and the harness will support it
- Add tools and pouches-enjoy the back support
- Cadmium-plated forged alloy steel hardware precisely engineered for maximum strength, durability and reliability
- 5000 lbs. tensile strength
- Parachute buckle leg straps
- Back and side D-rings



Item #	Size
DI1102009	Universal

DBI/SALA
Construction Vest Style Harness
Delta No-Tangle™

- Added back support and tool-carrying options
- Pass-thru buckle leg straps
- Back and without side D-rings
- Belt loops



Item #	Size
DI1103513	Universal



DBI/SALA

Construction Vest Style Harness

Delta No-Tangle™

- Added back support and tool-carrying options
- Pass-thru buckle leg straps
- Back D-ring
- Body belt with foam back pad and side D-rings

Item #	Size
DI1101643	Large



DBI/SALA

Construction Vest Style Harness

Delta No-Tangle™

- Added back support and tool-carrying options
- Tongue buckle leg straps
- Back D-ring
- Body belt with side D-rings
- Sewn-in back pad; sewn-in shoulder pads

Item #	Size
DI1101654	Medium
DI1101655	Large
DI1101656	X-Large



DBI/SALA

Vest Style Harness

Delta No-Tangle™

- With adjustable non-slip chest straps designed for comfort and stability
- Back D-ring
- Tongue buckle leg straps
- Shoulder retrieval D-rings
- Parachute buckles on lower shoulder straps
- Application: Fall arrest (FA), restraint (RT), rescue (RC)

Item #	Size
DI1101254	Universal



DBI/SALA

Vest Style Harness

Delta No-Tangle™

- Dorsal web loop
- Use with web loop lanyards for ultimate safety
- Reduced weight and electrical conductivity
- Pass-thru buckle leg straps
- Non-conductive/non-sparking PVC coated hardware

Item #	Size
DI1104730	Universal



DBI/SALA

Hi-Vis Work Vest Harness

Delta No-Tangle™

- Hi-vis work vest harness - reflective/orange
- Back D-ring, tongue buckle legs

Item #	Size
DI1107404	Universal



DBI/SALA

Shock Absorbing Lanyards

Shock Absorbing

ShockWave2™

- Polyester webbing with tensile strength from 5,750 to 9800 lbs. won't give out, even when you do
- At 5 to 7 stitches per inch, lanyards are sewn tough for rough action
- Our patented, user-friendly self-locking snap hooks open and connect without thumbs or fingers getting in the way
- Expands to 6 ft. and contracts to 4-1/2 ft.
- Abrasion resistant tubular webbing
- Self-locking snap hooks at ends; impact indicator
- With 2007153 aluminum hook (2-1/4" opening) at one end

Item #
DI1224311



DBI/SALA

Shock Absorbing Lanyard

Shock Absorbing

ShockWave2™

- Expands to 6 ft. and contracts to 4-1/2 ft. in reaction to your movements
- Reduces trip fall hazards, dragging and snagging for complete freedom of movement
- With aluminum hook (2-1/4 in. opening) at both ends
- Abrasion resistant tubular webbing for durability and longevity
- Impact indicator allows user to visually inspect unit for a fall
- 6 ft. in length; limits arresting forces to 900 lbs. or less

Item #
DI1244306



DBI/SALA

Shock Absorbing Lanyard

Shock Absorbing, 100% Tie-off

ShockWave2™

- Expands to 6 ft. and contracts to 4-1/2 ft. in reaction to your movements
- Reduces trip fall hazards, dragging and snagging for complete freedom of movement
- Twin-leg 100% tie-off style helps you remain connected at all times
- Abrasion resistant tubular webbing for durability and longevity
- Impact indicator allows user to visually inspect unit for a fall
- 6 ft. in length; limits arresting forces to 900 lbs. or less

Item #	Desc.
DI1244406	3 std. hooks, 3600 lb. gates
DI1244409	1 std./2 aluminum rebar hooks, 3600 lb. gates





DBI/SALA
Safety Lanyards

**Tie-Back, Shock Absorbing
EZ-Stop™ II**



- Tie-back design eliminates the need for a separate anchorage connector
- 1" polyester webbing with abrasion resistant tubular wear layer webbing for added durability and longevity
- Easy to use self locking snap hooks at both ends
- Floating D-ring provides adjustable tie-back point so lanyard can be choked off to itself
- Soft cover shock absorber for added worker comfort
- Length: 6 ft.
- Limits arresting forces to 900 lbs. or less

Item #
DI1221206

DBI/SALA
Safety Lanyards

**Retractable, Shock Absorbing
EZ-Stop® Retrax™**



- Stays close to the body, reducing trip falls, dragging and snagging
- Unique spring technology retracts and expands from 2-1/2 to 6 feet for complete freedom of movement
- Compact, lightweight device weighs only 2 lbs.
- Smooth retraction with no irritating lock-ups enhances ease-of-use and productivity
- Easy to use self locking snap hooks at both ends
- Limits arresting forces to 900 lbs. or less

Item #	Desc.	Gate Opening (in.)
DI1221460	with self locking snap hooks at both ends	NA
DI1221462	w/2007153 aluminum hook at one end	2 1/4

DBI/SALA
Safety Lanyards

**Shock Absorbing
EZ-Stop® II**



- 1" polyester webbing for durability and longevity
- Easy to use self locking snap hooks at both ends
- Soft cover shock absorber for comfort
- 6 ft. in length
- Limits arresting forces to 900 lbs. or less

Item #
DI1240006

DBI/SALA
Safety Lanyards

**Shock Absorbing
EZ-Stop® II**



- 1" polyester webbing with abrasion resistant tubular wear layer webbing for added durability and longevity
- Easy to use self locking snap hooks at both ends
- Floating D-ring provides adjustable tie-back point so lanyard can be choked off to itself
- Soft cover shock absorber for comfort
- 6 ft. in length
- Limits arresting forces to 900 lbs. or less
- Meets or exceeds all applicable industry standards including OSHA, ANSI and the stringent ANSI Z359

Item #
DI1241106

DBI/SALA
Shock Absorbing Lanyards

**Shock Absorbing, 100% Tie-off
EZ-Stop® II**



- Utilizes a tearing action when subjected to fall arrest forces, keeping the arresting forces under 900 lbs.
- Soft cover; 6 ft. long; 1" polyester web
- Twin-leg 100% tie-off type
- Self-locking snap hook at center, 2007153 aluminum hooks (2-1/4" opening) at leg ends

1240406: With self-locking snap hooks at all ends

Item #
DI1220416
DI1240406

DBI/SALA
Shock Absorbing Lanyards

**Shock Absorbing
EZ-Stop® II**



- Utilizes a tearing action when subjected to fall arrest forces, keeping the arresting forces under 900 lbs.
- 1" web, self locking snap hooks x 3 ft.

Item #
DI1240007

DBI/SALA
Shock Absorbing Lanyards

**Shock Absorbing
EZ-Stop® II**



- 1" polyester web and self locking snap hooks at each end, 6 ft. in length

Item #
DI1220256



DBI/SALA

Positioning and Restraint Lanyard

Chain Rebar Assembly

- Use positioning and restraint lanyards while rebar tying or construction of wall-forms
- Should only be used in applications that limit the free fall to two feet or less
- Twist link chain rebar lanyard; self-locking snap hooks on leg ends



Item #	Desc.
DI5920050	swivel flat steel hook 2½" opening gate 20½" long
DI5900051	swivel aluminum hook 2¼" gate opening 22" long

DBI/SALA

Positioning and Restraint Lanyard

Wall-Form Assembly

- Should only be used in applications that limit the free fall to two feet or less
- Twist link chain fits most wedge bolt slots or holes on wall forms
- Self-locking snap hooks at leg ends
- 1/4" tapered wall-form hook nose
- 3600 lb. gates
- 16" long



Item #
DI5904350

DBI/SALA

Self-Retracting Lifeline

Ultra-Lok®

- Comes with a durable glass-filled polyurethane housing, a 3/16" wire rope lifeline and aluminum side plates for maximum durability and minimum weight
- For added security has an anti-ratcheting twin disc brake system with an audio indicator to let you know it is functioning properly
- 30 ft. of 3/16" galvanized steel wire rope, self locking swivel hook with impact indicator
- Stainless steel working components for corrosion resistance
- Reserve lifeline retention system for added safety
- Swiveling anchorage loop to prevent twisting of lifeline



Item #
DI3504430

DBI/SALA

Self-Retracting Lifelines

Cable Ultra-Lok®

- View the impact indicator, located on the snap hook (for quick and easy inspection), to see if the unit has been impact loaded
- For ease of use and worker acceptance, our SRLs are the lightest in the industry at 9 lbs.
- Heavy-duty main spring maintains its exact retraction for the life of the product
- Corrosion-resistant stainless steel working components
- Reserve lifeline retention system
- 3/16" galvanized steel wire rope
- Self-locking swivel snap hook with impact indicator
- Swiveling anchorage loop to prevent twisting of lifeline



Item #	Length (ft.)
DI3504433	20
DI3504450	50

DBI/SALA

Self-Retracting Safety Lifelines

Web Talon™

- Engineered for reliable protection that locks when it should; won't lock when it shouldn't
- Self-retracting, all metal braking system for durability
- Self-locking hook with impact indicator
- Swiveling anchorage loop to prevent lifeline twisting
- 1" nylon webbing



Item #	Length (ft.)	Desc.
DI3101000	8	Standard Snap Hook
DI3101051	16	Swivel Snap Hook

DBI/SALA

Web Self-Retracting Lifelines

11' Web

- Rugged, heavy-duty (yet lightweight) cast aluminum housing
- Anti-ratcheting twin disc brake
- Reserve lifeline retention system
- 1" wide nylon webbing lifeline
- Self-locking swivel snap hook with impact indicator
- 11 ft. long



Item #
DI3103031



PROTECTA
Self-Retracting Lifelines

30' Cable
KRG Series



- Provides an economical SRL solution without compromising performance for safety
- 3/16" x 30' galvanized steel wire rope in thermoplastic housing with zinc coated internal components
- Swiveling snap hook with impact indicator and a self locking carabiner for use when mounting the unit to your anchor point
- It begins fall arrest within 2 ft. and has a red end-of-travel indicator, it works horizontally or vertically
- Weighs less than 10 lbs.

Item #
DIPAD215AG

PROTECTA
Self Retracting Lifeline

33' Cable
Rebel™



33' Self Retracting Lifeline with 5mm Galvanized Cable, Thermoplastic Housing and Carabiner.

- Ensures falls are stopped within a few inches, making Rebel™ SRL's safer than traditional lanyards
- Incorporates rugged aluminum or thermoplastic housing and stainless steel working components that can withstand rough use
- Unique speed sensing brake keeps forces to a minimum, and reduces clearance requirements. With a 420 lb. capacity (190kg), the worker is provided added versatility and tool carrying options

Features:

- Stainless steel or galvanized cable options available
- 2-year warranty on parts and workmanship, plus no annual re-certification is required; meets all applicable industry standards including OSHA and ANSI Z359.1

Item #
DI3590500



DBI/SALA
Rope Grabs

- Mobile type, automatically follows worker providing maximum freedom of movement
- Fits 5/8" diameter rope lifeline; they can be installed or removed at any point on the lifeline
- Use with 3 ft. EZ Stop® II shock absorbing lanyard 1240007



Item #
DI5000335

DBI/SALA
Rope Lifeline Assemblies

- 5/8" polyester/polypropylene blend rope
- Self-locking snap hook at one end
- Taped at other end

Item #	Length (ft.)
DI1202754	30
DI1202794	50
DI1202821	75
DI1202844	100
DI1202879	150
DI1202900	200



DBI/SALA
Horizontal Lifelines
Sayline™

- Lightweight and easy to install, and they are also extremely portable
- Easily installed with no special tools or equipment
- Lightweight
- Rope lifeline assembly with tensioner
- Two tie-off adapters; carrying/storage bag

Item #	Length (ft.)
DI7600506	60
DI7600510	100



DBI/SALA
Roof Anchor Fall Protection Kits

- Includes 2103673 roof anchor, 1224005 rope adjuster w/lanyard, 1103513 harness, 1203000 lifeline x 50 ft. with 5901583 counterweight and carry bag

Item #
DI2104168



DBI/SALA
Roof Anchors

Permanent

- Simply install by clamping onto joist, rafter, etc. (roof member)
- Complete with integral D-ring anchorage point
- Weather tight cap protects the anchor from corrosion by sealing it from the environment
- Complete with thermoplastic flashing to prevent water leakage through the roof
- 5,000 lb. Minimum breaking strength



Item #	Fits
DI2103670	2x8
DI2103671	2x10 to 2x12



DBI/SALA
Roof Anchors

Reusable

- Nail into the sheathing and joist, rafter, etc. (roof member)
- Steel construction; includes 20 16D nails for single use
- 3 lbs. total weight
- Complete with cadmium plated forged alloy steel D-ring
- 5,000 lb. Minimum breaking strength



Item #
DI2103676

DBI/SALA
Roof Anchor

Reusable

- Chain and O-ring
- 25" long
- Nail or screw into place



Item #
DI2103673

DBI/SALA
Roof Anchors

Disposable

- Quickly installed by first bending the anchor into shape and conforming it to the roof; then simply nail it into place through sheathing and truss on the roof or peak using ten 16d nails
- Material: Zinc plated steel
- Capacity: 310 lbs.
- Breaking Strength: 1,800 lbs. - rated for fall arrest



Item #
DI2103680

DBI/SALA
D-Ring Anchorage Plate

- Bolt or weld to structure
- Two 1/2" dia. attachment holes
- Plate size 1/4" x 2" x 4-1/4"
- Stainless steel plate, zinc plated D-ring



Item #
DI2101630

DBI/SALA
Sliding Beam Anchor

Glyder2™

- Provides complete horizontal mobility, tie-off overhead or at your feet (use with Force2 shock absorbing lanyard when used at your feet)
- Integrated ratcheting adjustment system provides quick and easy installation and removal
- Unique guarded locking mechanism protects the anchor from accidental disengagement
- Extremely lightweight at only 3.7 lbs., with a user capacity of 420 lbs. and a minimum breaking strength of 5,000 lbs.
- Replaceable synthetic wear pads
- Fits flange 3-1/2" to 14" wide and up to 1-1/4" thick



Item #
DI2104700

DBI/SALA
Tie-Off Adapters

Pass-Thru

- Pass-through design makes attaching to anchorage quick and easy
- 1-3/4" polyester strength member (5,000 lb. Min. tensile strength)
- 3" wide polyester wear pad
- Zinc plated steel hardware



Item #	Length (ft.)
DI1003000	3
DI1002004	4
DI1003006	6

DBI/SALA
Anchorage Connectors

Scaffold Choker

- 1" x 17" long polyester web
- Fits 3" max. diameter structure
- Zinc plated hardware



Item #
DI1201390

DBI/SALA
Steel Carabiners
Saflok®

- Self-closing/self-locking gate for increased safety and security
- Steel construction for durability
- User-friendly design for simple operation even while wearing gloves
- Rated gate of 3,600 lbs.
- Compatible with most connecting rings



Item #	Gate Opening (in.)
DI2000112	1/16
DI2000113	13/16
DI2000114	23/16



DBI/SALA
Trauma Strap

- Allows worker who is suspended to stand up in their harness to relieve pressure
- Continuous loop design allows for either one or two-foot suspension relief without pinching
- Can be attached to most harness brands/ styles right in the field
- Extremely compact and lightweight design stays out of the worker's way
- Deployment and operation is foolproof, simply unzip, and hook straps together



Item #
DI9501403

DBI/SALA
Confined Space Rescue

Retrieval Systems
Salalift® II Winch with Tripod

- Complete rescue system including tripod and Salalift® II winch
- Designed for durability and light weight, the UL classified 7' aluminum tripod is easy to set up and transport
- Rated working load is 350 lbs. for work support and 310 lbs. for fall arrest
- Designed for raising, lowering, work support or personnel rescue and features 60' of galvanized 1/4" steel cable
- Durable corrosion resistant construction featuring anodized aluminum side plates, zinc plated gears and shafts, stainless steel springs and aluminum drum for superior corrosion resistance



Item #
DI8300040

DBI/SALA
Personnel Rescue Retrieval Systems

Winch with Tripod

- The rated working load is 310 lbs. for fall arrest; the sealed SRL winch is intended for personnel rescue, though it may also be used for some raising and lowering of equipment
- Assembly includes: Sealed SRL winch, cable as selected, mounting bracket, winch carrying bag and 9 ft. aluminum tripod
- Galvanized cable 3/16" x 50'



Item #
DI8301020

DBI/SALA
Retro-Fit Tag
i-Safe™

- It can be 'choked' around an object and locked down with a permanent dome fastener; the scanner will pick up the encoded information right through the pouch; the tag is ideally suited for web materials, small diameter pipe and fixtures and can be attached without tools



Item #
DI9502059

DBI/SALA
PDA

i-Safe™

- The PDA enables the user to scan RFID tags and inspect product on site without having access paperwork and return product to a specific site to do the work
- Equipped with i-Safe™ Mobile Intelligent safety software
- Contains Microsoft® Windows Mobile™ Version 5.0
- ActiveSync 4.0 for quicker synchronization to your PC
- Integrated Multimedia player and SD card capability
- Complete with cradle and sync cable
- Carrying case included
- Full color screen
- Promag RFID reader



Item #
DI9000026

DBI/SALA
Ladder Safety System
Lad-Saf®

- ASK ABOUT INSTALLATION
- Hands-Free Climbing And Protection: The Lad-Saf™ sleeve automatically follows the user, can be attached anywhere along the cable and locks in the event of a fall
- Tension Indicator: Integrated tension indicating bottom bracket takes the guesswork out of installation
- Customizable: Hundreds of different brackets, styles and configurations to suit almost any application
- Corrosion Resistant Construction: Galvanized and stainless steel construction stands up to harsh environments for added longevity
- Shock Absorbing Design: Integrated shock absorbing top bracket reduces forces imposed on ladder structure during fall
- Intermediate Cable Guides: Prevents cable wear against the ladder and permits the climber to bypass without disconnecting



Item #
LAD-SAF SYSTEM



MILLER BY HONEYWELL

Harness Revolution™



- Web Finalis - Clip-on design safely organizes webbing after proper adjustment
- PivotLink™ Connection - Unique rotary design provides greater comfort in bending/mobility
- ErgoArmor™ Back Shield - Semi-flexible back shield minimizes impact from sharp/heavy snap hooks and self-retracting lifelines
- DualTech™ Webbing - Donning made easy with two-sided, contrasting color webbing and textures
- Cam Buckle - Easy, one-hand adjustment/release allows simultaneous adjustment of shoulder straps
- Self-Contained Label Pack - Integrated pack encapsulates labels minimizing damage and loss
- Integrated Accessory System - Modular attachment design provides connection points for belts/tools/accessories
- Rated to 400 lbs. capacity

Item #	Size
MYRDT-QC/SM	Sm/Med
MYRDT-QC/U	Universal
MYRDT-QC/XXL	XXL/XXXL
MYRDT-QC-BDP/U	Universal
MYRDT-QC-BDP/XXL	XXL/XXXL
MYRDT-TB/U	Universal

MILLER BY HONEYWELL

Arc-Rated Harness Revolution™



- The webbing offers the durability and FR properties of Kevlar® on the outer side, with softer FR Nomex® on the inside of the webbing for greater comfort
- PivotLink™ design allows unmatched freedom of motion and comfort, while the unique Cam Buckles provide easy two-finger adjustment
- Leather insulators under all metal hardware offer additional protection for the worker
- The Kevlar web loop on the back pad allows for a “metal-less” connection when used with a Kevlar shock-absorbing lanyard with a choke-off loop
- All Miller Revolution Arc-Rated Harnesses have bright red binding on every pad, making them easily identifiable as an Arc-Rated product
- Quick-Connect Chest Buckles; Cam Buckles
- ErgoArmor Back Shield
- Self-Contained Label Pack
- Web Finalis; Back D-Rings

Item #	Size
MYRKNAR-QC/UBK	Universal
MYRKNAR-TB/UBK	Universal

MILLER BY HONEYWELL
Harness Accessories
Revolution™



The PivotLink™ Connection provides attachment for accessories and tool pouches with a design that accommodates:

- Pouches, tool holders, cell phones, water bottles and more
- A tool belt that attaches and detaches – distributing weight across the hips and shoulders
- Universal attachment clips that fit on your existing accessories or tool rig and easily attach/detach

Item #	Desc.
MYRIA-T1	Mini Cell Phone Holder w/Snap-On Connector
MYRIA-T2	Regular Cell Phone/Jobsite Radio Holder, w/ Snap-On Connector
MYRIA-T3	Water Bottle Holder, 1 Qt.
MYRIA-T4	Large Open Bolt & Bull Pin Bag w/Quick-Release Tool Snap
MYRIA-T5	Medium Open Bolt & Bull Pin Bag
MYRIA-T6	2 Pocket Nail & Tool Pouch
MYRIA-T7	Large Multi-Pouch Tool Bag w/2 Steel Hammer Loops
MYRIA-T8	Padded Hammer Loop
MYRIA-T9	Open End Pliers & Tool Holder
MYRIA-T10	Zippered Cylindrical Utility Pouch

MILLER BY HONEYWELL

PivotLink Connection Kits Revolution™

The PivotLink Connection provides an attachment point for a multitude of accessories



- Pouches, tool holders, cell phones, water bottles and more
- A tool belt that easily attaches and detaches – distributing weight across the hips and shoulders
- Universal attachment clips that fit on your existing accessories or tool rig and easily attach/detach
- Accessory Kits & Rigs (Fits sizes 32" to 54")

Item #	Desc.
MYRIA-K2	Regular Cell Phone/Jobsite Radio Holder w/ Snap-On Connector, Water Bottle Holder, Large Multi-Pouch Tool Bag w/2 Steel Hammer Loops
MYRIA-R2	Belt w/Pad and PivotLink Attachments, 5 Accessory Connectors, Large Multi-Pouch Tool Bag w/ 2 Steel Hammer Loops, 2 Pocket Nail & Tool Pouch, Zippered Cylindrical Utility Pouch
MYRIA-R4	Belt w/Pad and PivotLink Attachments, 5 Accessory Connectors, 2 Large Open Bolt & Bull Pin Bags, Padded Hammer Loop



MILLER BY HONEYWELL
Optional Padding

Revolution™

- Shoulder/leg pads (2 pack)

Item #
MYRIA-P1



MILLER BY HONEYWELL
Belts

Revolution™

- Fits sizes 32" to 54"
- 5 accessory connectors

Item #	Desc.
MYRIA-B1	Belt only
MYRIA-B2	Belt w/ back pad



MILLER BY HONEYWELL
Harness Accessories

Connection Points
Revolution™

Item #	Desc.
MYRIA-C1	Sliding Belt Accessory Connectors (3 pack)
MYRIA-C2	Universal Accessory & Belt Attachment Clip (2 pack)



MILLER BY HONEYWELL
Identification Kits

Revolution™

- Self-adhesive windows with write-in window
- 10 pack

Item #	Desc.
MYRIA-BL	Blue
MYRIA-YL	Yellow
MYRIA-RD	Red

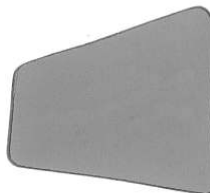

MILLER BY HONEYWELL
Non-Stretch Harness

HP™

- Rated to 400 lbs. capacity
- Self-contained label pack encapsulates labels minimizing damage and loss; integrated and oversized pull-free lanyard rings
- Comfort-touch back D-ring pad is designed with woven, breathable material for cooler extended wear comfort; orients harness for quick tangle free donning
- Bright 1" polyester webbing make the harnesses readily visible and easy to inspect
- Side and back D-rings; pull-up adjustment style



Item #	Size
MY650T-58	Universal

MILLER BY HONEYWELL
Non-Stretch Harness

- Rated to 400 lbs. capacity
- Self-contained label pack encapsulates labels minimizing damage and loss; integrated and oversized pull-free lanyard rings
- Bright webbing colors are easily visible enhancing compliance and inspection
- Back D-ring



Item #	Size
MY751L/XL	L/XL

MILLER BY HONEYWELL
Non-Stretch Harness

- Rated to 400 lbs. capacity
- Self-contained label pack encapsulates labels minimizing damage and loss; integrated and oversized pull-free lanyard rings
- Bright webbing colors are easily visible enhancing compliance and inspection
- Back D-ring



Item #	Size
MY8428-15-XL	XL
MY8428-15-XXL	XXL

MILLER BY HONEYWELL
Non-Stretch Harness

- Rated to 400 lbs. capacity
- Yellow 1-3/4" non-stretch polyester webbing with pull down adjustment is lightweight and durable
- Minimum tensile 5000 lbs. on webbing
- Steel hardware with brass grommets
- Back D-ring



Item #	Size
MY850-4	Universal



MILLER BY HONEYWELL
Stretchable Harness

DuraFlex®

- Rated to 400 lbs. capacity
- Self-contained label pack encapsulates labels minimizing damage and loss; integrated and oversized pull-free lanyard rings
- Bright webbing colors are easily visible enhancing compliance and inspection
- Back and side D-rings



Item #	Size
MYE650-77	Universal
MYE650-58SN	Universal

MILLER BY HONEYWELL
CoolMax Back Pad

- 6" wide pad for added comfort



Item #
MY9014

MILLER BY HONEYWELL
Harness Body Belt Accessories

- 1-3/4" black web belt with tongue buckle and 11 grommets

Item #	Size
MY6414N-S	Small
MY6414N-M	Medium
MY6414N-L	Large



MILLER BY HONEYWELL
Tool Lanyard

Bandit™

- Lanyard conveniently attaches to the user's belt
- Tools are attached with the carabiner or by cinching the cord around tool



Item #
MY9077

MILLER BY HONEYWELL
Titan™ Non-Stretch Harness

- Rated to 400 lbs.
- Sliding back D-ring
- Two pull-free lanyard rings
- Non-stretch



Item #
MYT4007

MILLER BY HONEYWELL
Relief Step™ Safety Device

- The Relief Step Safety Device provides support and enhances blood circulation until rescue – permitting the ability to move and flex leg muscles
- Small and lightweight; attaches to any brand full-body harness
- Utilizing two (2) Relief Steps (one for each leg/foot) assures greater comfort until rescue is completed



Item #
MY9099X

MILLER BY HONEYWELL
Web Lanyard

Adjustable

- Polyester webbing
- Two locking snap hooks
- 10 ft. length



Item #
MY210WLS

MILLER BY HONEYWELL
Stretchable Shock-Absorbing Lanyard
Manyard II

- Features a unique stretchable design that offers greater maneuverability and safety for the user by contracting 6 ft. to 4 ft.; greatly reduces the chances of tripping, snagging or dragging



Webbing:

- Safety Strap/Jacket: Green tubular polyester webbing
- Shock-absorbing web core: polyester
- 1" elastic

Technical:

- Max Working Load Capacity: 310 lbs. (141 kg)
- Snap Hooks: 5,000 lbs. (22kN) 3/4" (19 mm) gate opening
- Rebar Hooks: 5,000 lbs. (22kN) 2 3/4" (63 mm) gate opening

Item #	# of Legs	Harness Connection	Anchorage Connection
MY216M	1	Locking Snap Hook	
MY219M/6FTGN	1	Locking Snap Hook	Locking Rebar Hook
MY231M/6FTGN	2	Locking Snap Hook	Locking Rebar Hooks
MY232M	2	Locking Snap Hook	Locking Snap Hooks



MILLER BY HONEYWELL
Shock Absorbing Lanyards

**Shock-Absorbing
Manyard HP™**

- Features a special woven shock-absorbing inner core that reduces fall arrest forces, the heavy-duty tubular outer jacket serves as a back-up web lanyard



Webbing:

- Safety Strap/Jacket: Green tubular polyester webbing
- Shock-absorbing web core: polyester
- Steel Hardware

Technical:

- Max Working Load Capacity: 310 lbs (141 kg)
- Snap Hooks: 5,000 lbs. (22kN) 3/4" (19 mm) gate opening
- Rebar Hooks: 5,000 lbs. (22kN) 2 3/4 in. (63 mm) gate opening

Item #	# of Legs	Harness Connection	Anchorage Connection
MY216TWLS	1	Locking Snap Hook	
MY232TWLS	2	Locking Snap Hook	

MILLER BY HONEYWELL
Tie-Back Lanyard

**Shock Absorbing, 100% Tie-off
BackBiter™**

- The heavy-duty polyester webbing provides more abrasion resistance

Materials:

- Webbing: 1-3/8" Green Polyester
- SofStop® Shock Absorber
- Webbing: Polyester, Safety Strap (Inside SofStop®): 1-3/4" Polyester, 6 ft. long
- Miller 5K® snap hook provides 5,000 lb. gate load capacity from any angle



Item #	# of Legs	Harness Connection	Anchorage Connection
MY913B-SN	1 w/one 5K snap hook & 1 locking snap hook	Locking snap hook	Locking 5k snap hook
MY8798B-SN	2 w/two 5K snap hooks & 1 locking snap hook	Locking snap hook	Locking 5k snap hook

MILLER BY HONEYWELL
StretchStop® Lanyards w/Shock Absorber

100% Tie-off

Description:

- Combine the SofStop® Shock Absorber with a unique stretchable lanyard design (4ft.-6ft.) reducing tripping hazard
- Designed with a specially-woven inner core that smoothly expands to reduce fall arrest forces



Webbing:

- Safety Strap/Jacket: Green tubular polyester web, Shock-absorbing web core: polyester, 1" elastic
- Minimum Tensile: 5000 lbs. on webbing

Technical:

Max. Working Load Capacity: 310 lbs.

Item #	# of Legs	Harness Connection	Anchorage Connection
MY8798RSS	2	Locking snap hook	Locking snap hooks
MY8798SS	2	Locking snap hook	Locking rebar hooks

MILLER BY HONEYWELL

SofStop® Shock Absorber

- Designed with a specially-woven inner core that smoothly expands up to 42 inches to reduce fall arrest forces



Item #	Material	# of Legs	Harness Connection	Anchorage Connection
MY928LS	-	N/A	Locking snap hook	D-ring
MY910WLS	6' Webbing	One	Locking snap hook	
MY907NLS/6FTYL	6' Vinyl-coated wire rope	One	Locking snap hook	

MILLER BY HONEYWELL

Rebar Positioning Assembly

- Rebar chain assembly used for positioning
- Hardware: Steel, Zinc Plated
- Locking Snap Hooks: 3/4" gate opening
- Locking Rebar Hooks: 2-1/2" gate opening



Item #
MY6756RS



MILLER BY HONEYWELL

Fall Limiters

11'
MiniLite®



- Lightweight, compact design that fits in the palm of your hand – only 2.5 lbs.
- Offers up to 11 ft. of working capacity
- Quick-activating, high-strength stainless steel braking system
- Corrosion-resistant interior, frame and components
- No annual factory recertification required
- High-impact protective outer cover; visual load indicator
- Rated to 400 lbs. capacity when using a SofStop® shock absorber (928LS/18INYL), also rated 310 lbs. as-is

Item #	Connector
MYFL11-3	Carabiner and swivel shackle
MYFL11-6	Rebar hook swivel shackle

MILLER BY HONEYWELL

Self-Retracting Lifeline

MightyLite™



- Durable and dependable, corrosion-resistant stainless steel and aluminum housing
- No annual factory recertification required
- Ideal for hard-to-mount locations; carabiner and tagline included
- Rated to 400 lbs. capacity when using a SofStop® shock absorber (928LS/18INYL)

Item #	Material	Length (ft.)
MYRL20P	1" polyester webbing	20
MYRLS30G/30	3/16" galvanized wire rope	30
MYRL65G	3/16" galvanized wire rope	65

MILLER BY HONEYWELL

Personal Fall Limiters

9'
Scorpion™



- Attach directly to the harness D-ring for use as a personal fall limiter, or use as a traditional retractable lifeline
- Small, lightweight design 2.9 lbs.
- Quick-activating, high-strength stainless steel braking system – arrests free falls
- 9 ft. of working capacity
- Rated to 310 lbs. capacity
- No annual factory recertification required
- Visual load indicator – indicates the unit must be removed from service

Item #	Unit Connector	Lanyard End Connector
MYPFL-4	Scorpion w/carabiner and swivel shackle	Locking snap hook
MYPFL-6	Scorpion w/rebar hook and swivel shackle	Locking snap hook

MILLER BY HONEYWELL Self-Retracting Lifeline

Cable
Falcon



- Lightest composite unit on the market; corrosion-resistant stainless steel and aluminum internal components
- Smooth, quiet operation; engineered spring retraction tension designed not to pull or drag on a worker
- Dual swivels (unit top and snap hook) included on all cable models to minimize lifeline from twisting during use
- Improved load indicators identify when the unit needs to be removed from service
- 3/16" galvanized wire rope
- No annual factory recertification required; rated to 400 lbs. capacity when using a SofStop® Shock Absorber (928LS/18INYL)

Item #	Length
MYMP20G/20FT	20' Galvanized wire rope
MYMP30G/30FT	30' Galvanized wire rope

MILLER BY HONEYWELL

Personal Fall Limiters

6'
TurboLite™



- Extremely compact and lightweight (1.9 lbs.) provides 6 ft. working capacity lifeline; unit attaches directly to the harness back D-ring for greater mobility and versatility
- Engineered webbing for greater abrasion resistance and long service life
- High-strength, impact-resistant nylon housing for maximum durability; built-in swivel prevents lifeline from twisting
- No annual factory recertification required; rated to 400 lb. capacity

Item #	Unit Connector	Lanyard End Connector
MYMFL-11/6FT	Aluminum Twist-Lock Carabiner	Alum. Locking Snap Hook
MYMFL-12/6FT	Aluminum Twist-Lock Carabiner	Alum. Locking Snap Hook

MILLER BY HONEYWELL

Fall Protection System

100% Tie-off
Twin Turbo™



- Adapts two (2) lightweight Miller TurboLite™ Personal Fall Limiters (PFLs) for continuous 100% tie-off fall protection
- Replacement for double-legged shock-absorbing lanyards
- Innovative design that easily connects to the back D-ring of any fall protection harness; increases worker productivity and versatility with freedom of movement
- The swivel action prevents webbing from twisting and binding inside of the unit; webbing payout smoothly extends/retracts without interruption
- Easy-to-use and assemble/disassemble; adapts to most Miller TurboLite™ PFL models

Item #	Description
MYMFLB	Twin Turbo D-Ring Connector



MILLER BY HONEYWELL
Rope Grabs

- Compact design; corrosion-resistant stainless steel construction
- Lightweight and easy to use

Materials:

- Rope Grabs: Stainless Steel
- Rope Lanyard: 5/8" Synthetic Rope
- Web Lanyard: Polyester
- Snap Hook: Clear Zinc Chromate Plated Forged Alloy Steel Proof tested to 3,600 lbs.



Item #	Desc.
MY8174X	Stainless steel, manual rope grab for use with 5/8" or 3/4" synthetic rope
MY8174MLS	8174 with attached 4' Manyard shock-absorbing lanyard with locking snap hook

MILLER BY HONEYWELL
Safety Lifelines

Rope:

- 5/8" nylon
- A standard four-tuck splice is hand-crafted on each end, the ends of the rope are seared to prevent fraying; the last splice is treated with a nylon-based stiffening agent to prevent the splice from unraveling



Thimbles:

- A round, black plastic thimble is used in each lanyard eye to protect the eye from wear

Technical:

- Max. Working Load: 310 lbs. (141 kg)
- Minimum Tensile: 5,000 lbs. (22kN)

Item #	Length (ft.)
MY195R-2-25	25
MY195R-2-50	50

MILLER BY HONEYWELL
Safety Lifelines

Materials:

- Rope: Polypropylene/Polyester
- Snap Hook: Clear Zinc Chromate Plated Forged Alloy Steel
- Proof tested to 3,600 lbs.

Technical:

- Rope Diameter: 5/8"
- Min. Tensile Strength: 5000 lbs.



Item #	Length (ft.)
MY300L-2	25
MY300L-5	50
MY300L-7	75
MY300L-10	100

MILLER BY HONEYWELL

Temporary Roof Anchor

- Roof anchors are for temporary anchorage connection
- Two reusable anchors with screws



Item #
MYRA20-1

MILLER BY HONEYWELL

Grip™ Concrete Anchor

- A safe anchor point is established when the anchor is inserted into a properly-sized, cured concrete hole
- The reusable anchor can be removed and simply re-installed in a new location
- Designed for vertical or overhead/ceiling surface applications
- Constructed of stainless steel, aluminum and other non-corrosive materials for a longer service life
- Designed for use in cured concrete with a compression strength of at least 3,000 psi
- Color-coded to differentiate fall protection from multi-use models per OSHA regulations
- The structure or substrate that this product is anchored to must be capable of supporting 5,000 lbs. (22.2 kN) per user attached; or be designed, installed and used, under the supervision of a qualified person, as part of a complete personal fall arrest system which maintains a safety factor of at least two



Item #	Description
MY496	5,000 lb. ultimate strength; for single user connection; 400 lbs. max capacity

MILLER BY HONEYWELL

Wire Hook Anchor

Stainless steel wire hook connects to various approved anchorages including railings, small I-beams, angle iron and scaffolding. Squeeze the spring-loaded hook and slip the large opening over the approved structure.



- Max. Capacity: 400 lbs. (181.4 kg)

Item #
MY470

MILLER BY HONEYWELL

Cross-Arm Anchorage Connector

- Web straps wrap around I-beams and other structures
- Attaches with 2" D-ring that slips through 3" D-ring to form secure attachment
- 6 ft. length
- 400 lbs. maximum capacity



Item #
MY8183



MILLER BY HONEYWELL

Permanent Roof Anchor

- Ideal for new construction or as a retrofit on roofs with asphalt, shake or tile roofing materials
- Only the permanent D-ring(s)/anchor is exposed, providing a quick, safe fall arrest connection point(s)
- Stainless steel body construction, zinc-plated steel D-ring(s) resist corrosion for long service life
- Complete with 8, 16d nails



Item #

MYRA40

MILLER BY HONEYWELL

Cable Anchorage Connector

- Creates a quick and easy secure point of attachment; simply wrap the cable around an I-beam or other structure capable of withstanding 5,000 lbs. and connect the captive eye carabiner to the thimble at the opposite end of the cable
- Constructed of 1/4" vinyl-coated, galvanized wire rope, 6 ft. length
- Forged steel, auto-lock, captive eye carabiner with 1" gate opening
- Forged steel 3" O-ring



Item #

MY8187V

MILLER BY HONEYWELL

Carabiners

- Carabiners with spring loaded keepers are used as anchorage connectors; has a 1" gate opening and is plated to resist rust and corrosion
- 400 lb. maximum capacity



Item #

MY17D-1

MILLER BY HONEYWELL

Self-Retracting Lifeline with Retrieval Hoist

MightEvac®

- No annual factory recertification required
- Promotes quick and easy rescue with a 4:1 mechanical advantage
- 310 lb. weight capacity
- For emergency evacuation only
- Corrosion-resistant stainless steel/aluminum components
- Convenient, heavy-duty carrying handle
- 7 ft. tripod with mounting bracket
- Galvanized wire rope 3/16" x 50 ft.



Item #

MYMR50GC

MILLER BY HONEYWELL

Ladder Climbing Safety Systems

with Automatic Pass-Through

Vi-Go™

- Sleeves – Designed to follow the user along the lifeline while ascending or descending, instantly locking in the event of a fall
- Uninterrupted fall protection – Sleeve automatically bypasses intermediate cable guides, keeping both hands free for climbing; travels smoothly along cable and locks instantly in the event of a fall
- Easy, one-hand operation for attachment/detachment from the system
- Automatic pass-through cable guides secure lifeline to prevent cable wear and enable the system to accommodate curves
- Withstand Harsh Environments – Constructed with durable, corrosion-resistant aluminum and stainless steel components
- Attachment mechanism engineered to prevent incorrect installation, ensuring greater safety. Unit will not open if attached incorrectly
- Accommodates 5/16" or 3/8" cable



Item #	Length (ft.)	# of Cable Guides
MYVG/30FT	30	0
MYVG/50FT	50	1
MYVG/70FT	70	1
MYVG/110FT	110	2



GUARDIAN FALL PROTECTION

Full Body Construction Harness

Seraph

- Shoulder pads
- Six points of adjustment
- Stretchability in the shoulder straps
- Cradle seat
- Quick adjust torso buckles
- Padded waist belt
- D-ring lanyard keepers double as retrieval hoists
- Impact indicator & inspection log tag
- Hammer loops
- Tongue buckle leg straps



Item #	Size
GU11170	M-L
GU11171	XL, w/side D-rings
GU11172	XL
GU11173	M-L, w/side D-rings



GUARDIAN FALL PROTECTION
Retractable Lifeline

30' Cable

- Compact and lightweight design; stainless steel and non corrosive components extend the life of the unit
- Durable aluminum housing; high strength composite cable guide
- Quick-action braking system; comes with swivel top, swivel snap hook and boot cover
- 3/16" x 30 ft. galvanized cable



Item #	Weight
GU10916	15.00

GUARDIAN FALL PROTECTION
Heavy-Duty Retractable Lifeline

Cable
Edge Series

- Designed to be used specifically for leading edge work
- Galvanized cable; light weight, compact and durable aluminum housing; stainless steel and non-corrosive components for longer life
- Swivel top and swivel snaphook allow free movement of cable; impact indicator on the snaphook; integrated shock absorber pack with removable cover for inspection
- Quick action braking mechanism limits fall forces to 900 lbs. or less
- Self-closing carabiner included for attachment to top of housing; self-locking snaphook reduces potential for rollout



Item #	Length (ft.)
GU10925	30
GU10927	50

GUARDIAN FALL PROTECTION
Retractable Lifeline

11' Web

- Ergonomic frame makes handling more comfortable; quick-action braking system
- No recertification required, considered a disposable unit

Specifications:

- Pawls: Machined 304 Stainless Steel
- Reel Body: Glass reinforced nylon
- Brake Ring & Brake Body: Machined 304 Stainless Steel
- Anchorage Connection: Zinc plated alloy steel carabineer (5,000 min. tensile strength)
- Snap Hook: Zinc plated alloy steel snap hook (5,000 min. tensile strength)
- Housing: High strength aluminum; Webbing – Nylon: 1" x 11 ft.
- Weight: Less than 4 lbs.; Capacity: 310 lbs.
- Max. Arresting Force: 900 lbs.; Max. Arresting Distance: 42"
- Average Locking Speed: 4-1/2 ft/sec



Item #
GU10900

GUARDIAN FALL PROTECTION
Cable Retractable Lifeline

50'
Edge Series

- Corrosion-resistant stainless steel and aluminum components
- Dual braking mechanism operates quickly, arresting a fall within two feet while giving flexibility for use
- Dual-swivel design allows for greater mobility while keeping the lifeline in good working condition
- Simple design allows for quick inspection and turn around
- Each retractable includes a steel twist-lock carabiner and tagline
- Limited nuisance lock up
- 3/16" x 50' galvanized cable with swivel top and swivel snap hook



Item #
GU10917

GUARDIAN FALL PROTECTION
Retractable Lifeline

Cable
Aardvark

- Spring Loaded Absorber: The spring loaded absorber limits the redundant locking up of the retractable, saving costly repairs, and making it easier to use
- Steel Framed Housing: The steel plate insert molded into the ultra lightweight housing provides added strength and durability to the retractable
- Triple Locking Device: New pawl design creates backup safety features so that the retractable will lock up well within ANSI guidelines



Item #	Length (ft.)
GU10989	16
GU10985	25
GU10987	50

GUARDIAN FALL PROTECTION
Shock Absorbing Lanyards

- 1" x 6 ft. nylon webbing is light and durable
- Clear shock absorber pack for easy inspection
- Easy to use self double locking rebar hooks



Item #
GU01231

GUARDIAN FALL PROTECTION
Tool Lanyard

- Helps reduce falling object related injuries
- Securely attach tools to wrist or tool belt
- Two connection options for ease and versatility
- With mini carabiner



Item #
GU10726



GUARDIAN FALL PROTECTION
Horizontal Rope Lifeline System

- Two person temporary reusable system for fall arrest
- 5/8" braided polyester rope
- Rope tensioner
- Two anchorage web slings; Two self-locking carabiners
- Two O-rings
- Storage bag



Item #	Length
GU04625	30
GU04628	60
GU04630	100

GUARDIAN FALL PROTECTION

Fall Protection Kits
Bucket of Safe-Tie

Includes:

- Universal harness with 5 points of adjustment for added comfort
- 50' Vertical Lifeline Assembly with Shock Pack, and permanently attached Positioning Device with 18" lanyard extension to keep device within reach
- 1 HD Temper Reusable Anchor



Item #
GU00815

GUARDIAN FALL PROTECTION

3-Way Rescue Retrieval Retractable Lifeline

- Easy handle feature allows for quick adjustment
- High-quality machined parts make the product durable and dependable
- Proprietary design of internal mechanisms
- Capacity: 310 lbs.
- Max. Arresting Force: 900 lbs.; Max. Arresting Distance: 42"
- Average Locking Speed: 4-1/2 ft./sec.



Item #
GU10974

GUARDIAN FALL PROTECTION

Concrete Anchor Strap

- As a disposable anchor point, can be used in other applications such as wood framing members, rebar, pipe racking, etc.
- As always, make sure that your anchor strap is attached to a structure capable of supporting 5,000 lbs.
- 6 ft. long



Item #
GU10717

GUARDIAN FALL PROTECTION

Arc-O-Pod Rescue & Retrieval Kit

- 7 ft. aluminum tripod is lightweight and portable
- Adjustable locking legs adjust quickly in increments of 2" and are kept in position with locking push pins - and will span a 5-1/2 ft. diameter hole
- Complete with safety chain to prevent movement and safety shoes that incorporate a rubber sole for flat surfaces and spiked edges for slippery surfaces
- Heat-treated cast aluminum head incorporates a built-in pulley system to rout lifeline of mechanical device directly over opening; also equipped with drop-forged steel eyebolts for use as anchorage point for secondary or back-up system
- Complete with quick-mount bracket for attachment of Guardian 3-Way mechanical device for ease of use
- Rated working load is 350 lbs. for work support and 310 lbs. for fall arrest and can withstand up to 5,000 lbs. of vertical pull
- Comes with bag, bracket, pulley, chains



Item #
GU15030

GUARDIAN FALL PROTECTION

Standing Seam Roof Clamp

- Designed for use with retractable lifelines; 10" x 12" base plate with 7-1/2" post
- Reusable temporary anchor point; mounts to flat wood or metal roofs
- Fits most retractable lifelines up to 50'; allows retractable to rotate 360 degrees



Item #
GU00250

GUARDIAN FALL PROTECTION

Concrete Grip Anchor

- Designed for use in cured concrete with a compression strength of at least 3000 psi
- Reusable, temporary; installation is easy, just compress spring and insert cable shaft into hole
- Great for anchoring scaffolding; for use on vertical, or overhead applications
- 3/4" hold diameter, 3" deep minimum; 5,000 lbs. capacity
- Designed for single user connection



Item #
GU00235



GUARDIAN FALL PROTECTION
Beam Anchor

Beamer™ 2000



- Designed specifically for use at your feet and overhead
- Nylon bushings provide smooth movement along beam & act as an impact indicator in the event of a fall
- Fits 3.5" - 14" beams
- Weather-resistant
- Reusable and extremely durable
- Ratcheting end piece
- Lightweight
- Slides easily in both directions
- Welding spatter does not stick to aluminum bar
- No tools are needed for fast installation
- Precision machined aluminum bar
- One handed operation

Item #
GU00101

GUARDIAN FALL PROTECTION
Permanent Roof Anchor
Skyhook



- Patented permanent anchor point for
-Wood; 3/4" cdx plywood or better
-Metal; 20 gauge or thicker
- Powder-coated for a durable weather proof finish
- Wood/metal fasteners provided
- Perfect for use with our cable horizontal lifeline system
- Skyhook Swivel Top can mount on top of Skyhook

Item #	Pitch
GU00300	Flat
GU00320	1/12 - 6/12
GU00340	10/12 - 12/12

GUARDIAN FALL PROTECTION
Permanent Roof Anchor
CB-12 & CB-18



- Universal base plate
- Durable galvanized finish
- Fasteners provided for wood & steel
- For use on wood, steel or concrete
- Post extends past roofing substrate to keep attachment point high enough that it is still accessible after the roof is complete
- Round post works with most off-the-shelf flashing kits
- Great for use with retractable or horizontal lifeline systems

Item #	Size
GU00645	12" post
GU00656	18" post

GUARDIAN FALL PROTECTION
Ladder Extension System
Safe-T Ladder™



Designed to attach over the top of the ladder and provide a safe and easy transition from the ladder to a second surface; requires no tools, drilling or bolting to hold it securely in place; once installed, the unit provides two offsetting handrails that can be used to walk through and step on or off the ladder

- Simple to use knob, tightens by hand without scratching or damaging ladder
- Safety latch prevents unit from slipping off ladder; cushioned bumper pads help to protect the eaves of the roof
- Added hand grips for safe and easy use

Item #
GU10800

GUARDIAN FALL PROTECTION
Basemate Ladder Stabilizer



- Cuts the risk of falls by allowing ladders to remain stable on uneven ground
- Easily attaches to the bottom of any standard ladder
- Wide base gives added support/stability to extension ladders
- Made of hardened steel; Weight tested to 1,200 lbs.
- Patented triple action locking system with one foot operation (patented design)
- Installation to most fiberglass, aluminum and wood extension ladders (12" to 20" rung width)
- Adds less than 12 lbs. to the base of the ladder

Item #
GU02475

GUARDIAN FALL PROTECTION
Swivel Anchor Point



The MEGA Swivel incorporates a custom design to its components to give it's incredible strength. The D-Ring used a heavy gauge heat treated steel, Reinforced Bridge and Locking Caps. The Locking Caps slot into the Swivel Housing preventing the D-Ring from spreading outwards during heavy loads. The Bridge keeps the D-Ring from collapsing. The Swivel Housing allows the D-Ring to flip back and forth as wells rotate at 360 degrees.

Specifications:

- Safe working load: 2,000 lbs; ultimate breaking strength: 10,000 lbs
- Material: Drop forged alloy steel
- Hardware for concrete: Custom designed bolt (3,000 psi); Hardware for steel: 5/8" grade 8 bolt, lock washer & nut
- Rates for 4 men HLL systems
- Rotates 360° degrees; flips 180° degrees
- Used for steel flanges or concrete substrate

Item #	Base Material
GU0237	Steel
GU0238	Concrete

Honeywell

HONEYWELL **Biosystems TOXILT^D**

Single-Sensor Gas Monitors

ToxiLTD is a 2-Year Disposable Single-Sensor Gas Monitor with features such as optional continuous real-time gas readings, top and front high intensity LED visual alarm light, event logger and a calibration reminder.



- Inquire about Optional docking station

Item #	Description
BIO54-44-01	CO
BIO54-44-02	H2S

HONEYWELL

Biosystems MULTIPROTM

Confined Space Gas Detector

The MultiPro is the smallest and easiest to use confined space gas detector offered by Honeywell Analytics. It offer real time readings of up to 4 gases simultaneously, one-button operation including calibration, an easy to read LCD display, audible, visible and optional vibrating alarms, standard event logger and black box data logger, an IrDA port for easy communication with a PC, and an optional sample draw pump.



Sensors and Calibration:

- Three sensors; O₂, LEL and CO, H₂S or combined CO/H₂S sensor
- User replaceable sensors
- One button auto calibration
- Calibration due reminder
- Sensor span reserve indicators during calibration for predictive maintenance

Item #	Desc.
BIO54-48-300	LEL/O ₂
BIO54-48-301	LEL/O ₂ /CO
BIO54-48-302	LEL/O ₂ /H ₂ S
BIO54-48-314	LEL/O ₂ /Duo-Tox (CO/H ₂ S)

HONEYWELL

Biosystems MultiPro Remote Accessories

Continuous Sample Pump

- Continuous sample pump for MultiPro
- Includes 10' of sample tubing and sample probe assembly



Item #
BIO54-49-102

HONEYWELL

Biosystems PHD6TM

Multi-Sensor Gas Detector

The PHD6 is the most configurable gas detector made with 5 sensor ports, up to 6 channels of detection, and over 16 sensor options including electrochemical, LEL, PID and Infrared.



- 5 Sensor Ports and 16 Sensor Options: With 16 sensor choices, including PID, IR-CO₂, IR-CH₄, conventional LEL, oxygen and 11 different toxic gas sensors including Duo-Tox, the PHD6 can be configured for just about any use
- PID Sensor Option: PID sensor monitors for hundreds of known VOCs
- IR CO₂ Sensor Option: For breweries, wineries and anywhere accumulations of CO₂ can be an issue
- Electrochemical Sensor Option: Choose from 11 different electrochemical toxic gas sensors
- LEL Sensor option: A catalytic hot-bead LEL sensor is available for the detection of combustible gases and vapors
- IR CH₄ Sensor Option: Poison-proof technology for use in situations where a conventional LEL sensor can fail
- Interchangeable Battery Packs: Both Li-Ion and Alkaline battery packs offer up to 24 hour run times
- IQ Dock Compatibility: Reduce labor costs, automate record keeping and save calibration gas all at the same time with the IQ6 Dock

Suffixes:

- Battery Type: A (Alkaline instrument only) N (Rechargeable (Li-Ion) instrument only)
- Calibration Kit (Optional): V (Value pack; includes small cylinder of calibration gas, regulator and foam-lined hardshell carrying case, alkaline only) C (Complete kit; includes large cylinder(s) of calibration gas, regulator and waterproof, foam-lined hardshell carrying case)
- Select Upgrades (Optional): D (datalogging upgrade) Y (vibrating alarm upgrade) W (datalogging and vibrating alarm upgrade)

FOR ADDITIONAL CONFIGURATIONS CALL EDGE

Item #	Description
BIO54-53-A01028000	O ₂ /CO/H ₂ S/LEL
BIO54-53-A1025080	O ₂ /CO/H ₂ S/IR0CO ₂ /LEL
BIO54-53-A01025100	O ₂ /CO/H ₂ S/IR-CH ₄
BIO54-53-A1025280	O ₂ /CO/H ₂ S/LEL/PID
BIO54-53-A02198000	O ₂ /H ₂ S/CO-H/LEL
BIO54-53-A02195080	O ₂ /H ₂ S/CO-H/IR-CO ₂ /LEL
BIO54-53-A02195100	O ₂ /H ₂ S/CO-H/IR-CH ₄
BIO54-53-A02195280	O ₂ /H ₂ S/CO-H/LEL/PID
BIO54-53-A14008000	O ₂ /Duo-Tox(CO/H ₂ S)/LEL
BIO54-53-A14005080	O ₂ /Duo-Tox(CO/H ₂ S)/IR-CO ₂ /LEL
BIO54-53-A14005100	O ₂ /Duo-Tox(CO/H ₂ S)/IR-CH ₄
BIO54-53-A14005280	O ₂ /Duo-Tox(CO/H ₂ S)/LEL/PID
BIO54-53-A03148000	O ₂ /SO ₂ /Duo-Tox(CO/H ₂ S)/LEL
BIO54-53-A06148000	O ₂ /NO/Duo-Tox(CO/H ₂ S)/LEL
BIO54-53-A09148000	O ₂ /NO ₂ /Duo-Tox(CO/H ₂ S)/LEL
BIO54-53-A10148000	O ₂ /HCN/Duo-Tox(CO/H ₂ S)/LEL
BIO54-53-A14158000	O ₂ /SO ₂ (Ext. Range)/Duo-Tox(CO/H ₂ S)/LEL
BIO54-53-A14188000	O ₂ /Duo-Tox(CO/H ₂ S)/CL ₂ (Specific)/LEL
BIO54-53-A14218000	O ₂ /Duo-Tox(CO/H ₂ S)/NH ₃ /LEL
BIO54-53-A03148000	O ₂ /SO ₂ /Duo-Tox(CO/H ₂ S)/LEL



Honeywell

HONEYWELL

Biosystems Automatic Docking Stations

Automatic docks will be the nerve center of your gas detection program. Simply place an instrument into the dock. These docks automatically bump test each instrument, automatically download detector event and maintenance data, automatically check each detector for more than 12 different performance functions, automatically run a full calibration if the unit requires it...then automatically make all of that data available to you...in clear, easy-to-read reports.



Dock Software:

- There are 2 software programs available for PC interface

Docking Station Software:

- Allows you to easily customize the instrument's settings
 - Configures dock options including calibration gas set-up
 - Provides docking station live bump and calibration testing status
- Database Management Software:

- Allows you to access and manage the data for all instruments in your database

Item #	Description
--------	-------------

IQ Express™ Automatic Docking Stations for ToxiPro/Ltd/3Ltd Gas Monitors

BIO54-46-9000	Docking Station, stand alone or USB set up, standard version (for O2, CO or H2S)
BIO54-46-9100	Docking Station, stand alone or USB set up, enhanced version (for O2, CO, H2S, SO2, Cl2, NO2, NH3, HCN or PH3)
BIO54-46-9000N	Docking Station, Ethernet-ready standard version (for O2, CO or H2S)
BIO54-46-9100N	Docking station, Ethernet-ready enhanced version (for O2, CO, H2S, Cl2, NO2, NH3, HCN or PH3)

MultiPro IQ Express™ Automatic Docking Stations for MultiPro Multi-Gas Monitor

BIO54-49-9000	Docking station, stand alone or USB setup
BIO54-49-9000N	Docking station Ethernet-ready

IQ6™ Automatic Docking Stations for PHD6 Multi-Gas Monitor

BIO54-54-9200	2-ports, * stand alone or USB set up
BIO54-54-9200N	2-ports, * Ethernet-ready
BIO54-54-9400	4-ports, ** stand alone or USB set up
BIO54-54-9400N	4-ports, ** Ethernet-ready

*** 2-port version recommended for standard CO, O2, H2S and LEL sensors configuration**

**** 4-port version recommended for units with IR sensor, PID sensor or non-standard configuration**

JACKSON

KIMBERLY CLARK

Hard Hats

BlockHead™

Jackson Safety



- Meets ANSI Z89.1 Type 1, Class C, G, and E
- Full 360 degree brim adds protection from nature's elements
- High Density Polyethylene (HDPE) - 16.3 oz.; 8 pt. ratchet suspension

Item #	Color
JS3014874	White

KIMBERLY CLARK

Hard Hats

Charger™

Jackson Safety



- Meets ANSI Z89.1 Type 1, Class C, G and E
- High Density Polyethylene (HDPE) - 13.5 oz.
- Contoured dome maximizes protection; 4 pt. ratchet suspension

Item #	Color
JS3013372	Neon-Pink

KIMBERLY CLARK

Hard Hats

Sentry III™

Jackson Safety



- High Density Polyethylene (HDPE) - 12.5 oz.
- 6 pt. ratchet suspensions offer two additional points of impact absorbance
- Can be printed with private label/logo

Item #	Color
JS3000061	Yellow
JS3000064	White
JS3000067	Gray
JS3000070	Green
JS3000072	Blue
JS3000075	Red
JS3000078	Orange
JS3000085	Hi-Viz Orange

JACKSON

KIMBERLY CLARK **Bump Caps** Jackson Safety



- For work situations that do not require ANSI hard hat protection
- Molded from high-density polyethylene for lightweight comfort

Item #	Color
JS3001937	White
JS3001938	Dark Green
JS3001939	Dark Blue
JS3001941	Red

KIMBERLY CLARK **Nylon Brackets**

Huntsmen A-5500SN Jackson Safety

- Dielectric
- Fits most safety caps with-out slots
- Heavy-duty rubber cord holds bracket in place



Item #
JS3000447

KIMBERLY CLARK **Faceshield Bracket**

Huntsmen A-5500X Jackson Safety

- Lightweight 100% nylon bracket
- For slotted cap, pivots up and secures in 3 different positions



Item #
JS3000448

KIMBERLY CLARK **Winter Liner**

225 Plus Jackson Safety

- Three layers of thick foam under a blue 100% quilted nylon shell



Item #
JS3000442

KIMBERLY CLARK **Winter Liner**

Windjammer™ IV Jackson Safety

- Silver with black fastener straps and elastic border stitching



Item #
JS3005346

KIMBERLY CLARK **Winter Liner**

AA-7 Windgard™ Jackson Safety

- Knitted tube cap style traps warmth and prevents moisture build-up, keeps wind out
- Flame retardant treated polyester - Navy blue color



Item #
JS3000434

KIMBERLY CLARK **Winter Liner**

AA-8 Windgard™ Jackson Safety

- Knitted tube hat style for 360 degree brim hats - Red color
- Warmth for temps 32° to 0° F (0° to -20°C)



Item #
JS3000436

KIMBERLY CLARK **Winter Liner**

400 Jackson Safety

- Full head and neck coverage with extra-long nape and wrap-around collar
- 100% cotton, denim exterior; Thick, sherpa lining for maximum warmth



Item #
JS3000441

KIMBERLY CLARK **Pinlock Suspension** Jackson Safety

- Replacement 6 pt. pinlock suspension for Sentry III

Item #
JS3000094



KIMBERLY CLARK **Ratchet Suspension** Jackson Safety

- Replacement 6 pt. ratchet suspension for Sentry III

Item #
JS3000095



KIMBERLY CLARK **Ratchet Suspension** Jackson Safety

- Replacement 8 pt. ratchet suspension for Blockhead

Item #
JS3014879



KIMBERLY CLARK **Drybrow Sweatbands** Jackson Safety

- Keep cool and prevent perspiration from running into your eyes

Item #	Desc.
JS3005334	AA-100 Elastic Band
JS3305336	AA-102 Clip-on



KIMBERLY CLARK **Replacement Sweatbands** Jackson Safety

- Replacement sweatband for hats and caps
- Made of a Coolmax® terry cloth material to wick away user's perspiration for comfort
- Sweatband only (hat not included)



Item #
JS3000105



MSA

MINE SAFETY APPLIANCES CO.

Protective Caps

Skullgard®

- Skullgard® caps feature heavy-duty construction for use in steel mills and other heavy industries
- Skullgard® caps meet or exceed the applicable requirements for a Type I helmet (top impact) as outlined in ANSI Z89.1 1997, class G (electrical—low voltage) (formerly class A)



Item #	Color	Style
MIN475395	Natural Tan	Cap
MIN475407	Natural Tan	Hat

Fas-Trac Suspension For Above

MIN473334

MINE SAFETY APPLIANCES CO.

Safety Caps

V-Gard®

- 4-point Fas-Trac® polyethylene shell and suspension
- The rigid shell is lightweight and balanced for all-day wearing comfort
- The shell is one-piece injection-molded of high-density polyethylene and has high dielectric strength



Item #	Color
MIN475358	White
MIN475359	Blue
MIN475360	Yellow
MIN475361	Orange
MIN475362	Green
MIN475363	Red

MINE SAFETY APPLIANCES CO.

Vented Safety Caps

V-Gard® Advance®

- Cooling vents for improved air circulation
- Lightweight design for added comfort
- Lateral contours above the ear for easy integration of hearing protection
- 4-point Fas-Trac® suspension
- Glaregard™ under brim to reduce reflective glare



Item #	Color
MIN10034018	White

MINE SAFETY APPLIANCES CO.

Terri-Band Sweatbands

- Custom design fits all MSA helmets; washable and has plastic snaps
- 10 per package



Item #
MIN696688

JACKSON

KIMBERLY CLARK Safety Glasses



Nemesis™

Jackson Safety

- Sleek, sporty style; soft touch temples
- Lightweight construction; single lens wrap-around protection

Item #	Lens Color	Frame Color
JS3000354	Clear	Black
JS3000356	Smoke	Black
JS3000357	I/O Lens	Black
JS3000358	Blue Mirror	Black
JS3000359	Amber	Black
JS3011375	Copper	Camo
JS3020706	Clear	Camo
JS3020707	Smoke	Camo
JS3020708	Amber	Camo
JS3020709	Smoke	Inferno Red

KIMBERLY CLARK Safety Glasses



30-06 Readers

Jackson Safety

- Polycarbonate lenses
- Base curve 7

Item #	Frame/Lens Color	Diopter Strength
JS3011712	Tortoise/Brown	+1.5
JS3011713	Tortoise/Brown	+2.0
JS3011717	Black/Clear	+1.5
JS3011718	Black/Clear	+2.0
JS3011719	Black/Clear	+2.5

KIMBERLY CLARK Safety Glasses



Element™

Jackson Safety

- Lightweight design; universal nose bridge for comfort
- Base Curve 9.5; high impact and 99.9% UV protection

Item #	Lens Color	Frame Color
JS3004880	Clear	Black
JS3004882	Smoke	Black

JACKSON

KIMBERLY CLARK
Safety Glasses



HellRaiser™
Jackson Safety

- Steamlined, sunglass styling; extreme lightweight design
- High performance polycarbonate lens; flex point temples for comfort and stability
- Base Curve 8

Item #	Lens Color
JS3013851	Clear
JS3013854	Smoke
JS3013856	I/O
JS3013858	Blue Mirror

KIMBERLY CLARK
Safety Glasses



Platinum X™
Jackson Safety

- Gunmetal X-frame makes the eyewear flexible with a secure fit
- Scratch-resistant polycarbonate wraparound lens, 8-base curve and 99.9% UV protection
- Hinge stops to help to prevent lens damage while the contoured, soft-touch rubber temples allow for all-day comfort

Item #	Lens Color
JS3023031	Clear
JS3023032	Smoke
JS3023033	Indoor/Outdoor
JS3023034	Amber

KIMBERLY CLARK
Safety Goggles



MonoGoggle® 202 Series
Jackson Safety

- Chemical splash goggle; .060 polycarbonate lens

Item #
JS3005052

KIMBERLY CLARK
Headgear

Model K
Jackson Safety



- Soft, absorbent wrap-around foam cushioned sweatband gently hugs the natural shape of the head
- High performance ratchet; crown assembly pivots up; low-riding nape strap for firm fit
- Faceshield window not included

Item #
JS3000001

KIMBERLY CLARK
Faceshields
Jackson Safety



- Polycarbonate: Optical-grade thick polycarbonate from extruded sheet or injection molded resin provide superior secondary impact protection and increased scratch resistance
- Petg: Provides quality impact protection at an economical price. Ideal for any worker who needs light impact protection and is not exposed to high heat applications, offers good scratch resistance and distortion free optics

Item #	Size (in.)	Color	Type
JS3005399	8 x 15.5	Clear	PETG
JS3005379	8 x 15.5	Dark Green	Polycarbonate
JS3005378	8 x 15.5	Clear	Polycarbonate
JS3005371	8 x 15.5	Clear	Polycarbonate

UVEX

by Honeywell

UVEX BY HONEYWELL
Safety Glasses



Bandit™
Uvex

- Wrap-around frame has a dual lens look, but is actually a single lens with molded-in sideshields and brow guards for complete protection and excellent visibility
- Sleek sporty design; great fit with adjustable spatula temples
- Providing 99.9% UV protection
- Uvextreme® AF (XTR), the revolutionary new anti-fog, anti-static, anti-scratch and anti-UV coating

Item #	Lens Tint & Coating
--------	---------------------

Black Frame

UVS1603 Espresso UD

Slate Blue Frame

UVS1620X Clear XTR

UVS1624 Mirror UD

Replacement Lenses

UVS6310X Clear XTR

UVS6311 Amber UD

UVS6312 Espresso UD

UVS6313 Mirror UD

UVS6314 SCT-Reflect 50 UD



UVEX BY HONEYWELL
Safety Glasses

Genesis®
Uvex



- Patented dual 9-base wrap-around lens
- Soft elastomer browguard; three position ratchet lens inclination
- Ventilation channel between frame and lens
- Lens design follows cheekbone contour; soft, flexible “fingers” bridge adjusts to nasal profiles
- Meets military Vo ballistic test for impact
- Meets ANSI Z87+ (High Impact) and is certified to CSA Z94.3 standards

Item #	Lens Tint & Coating
--------	---------------------

Black Frame

UVS3200X	Clear XTR
UVS3201X	Espresso XTR
UVS3202	Amber UD
UVS3203	Mirror UD
UVS3204	SCT-Reflect 50 UD

Replacement Lenses

UVS6900X	Clear XTR
UVS6901X	Espresso XTR
UVS6902	Amber UD
UVS6903	Mirror UD
UVS6904	SCT-Reflect 50 UD

UVEX BY HONEYWELL
Safety Glasses

Astrospec® OTG 3001
Uvex



- Large enough to fit over most prescription spectacles yet light weight
- Patented Duoflex™ temples; adjustable temple length
- Patented lens inclination system
- Single-piece panoramic lens; unique lens replacement system
- Impact resistant polycarbonate lenses block 99.9% of UV rays
- Meets military Vo ballistic test for impact
- Meets ANSI Z87+ (High Impact) and is certified to CSA Z94.3 standards

Item #	Lens Tint & Coating
--------	---------------------

UVS2500C	Clear XTR
UVS2504C	Gray XTR

Replacement Lenses

UVS561	Clear XTR
UVS562C	Gray XTR

UVEX BY HONEYWELL
Stealth® Goggles

Uvex



- The easiest lens replacement system
- Exclusive Uvextreme® AF lens coating provides anti-fog, anti-scratch, anti-static, and anti-UV protection
- Unique toric lens design offers a close fit, superior optics, and dramatically improved peripheral vision
- Elastomer seal stays amazingly soft, pliable, and comfortable for the life of the frame

Item #	Lens Tint & Coating
UVS3960C	Clear XTR

Replacement Lenses

UVS700C	Clear XTR
---------	-----------

UVEX BY HONEYWELL
Eyewear Hang Cords

Uvex



- Black universal neck cord
- Provide convenient access to safety eyewear and encourage greater compliance

Item #
UVS501

UVEX BY HONEYWELL
Eyewear Pouch

Uvex



- Nylon drawstring pouch fits most Uvex eyewear to protect lenses from scratches and abrasion

Item #
UVS487

UVEX BY HONEYWELL
Lens Cleaner Towelettes

Uvex



- Handy pocket size towelettes, pre-moistened with Uvex Clear® lens cleaning solution, are ideal for anti-fog coatings and scratch-resistant coatings
- Does not contain silicone
- 100 per box

Item #
UVS468

UVEX BY HONEYWELL
Fog Eliminator Cloths

Uvex



- Formulated to effectively protect lenses from all types of fogging caused by cold, high humidity or sudden temperature changes; safe for all surfaces, including polycarbonate and glass
- Streak and film free, alcohol and silicone free; non-flammable and non-toxic
- Each cloth provides multiple applications; 100 per box

Item #
UVS477



EDGE EYEWEAR

Dakura Safety Glasses

Polarized



- Black frames wraparound design
- Provide 99.9% protection from UVA, UVB and UVC rays
- High Velocity Impact Resistant - .25" steel ball at 150 ft/s (ANSI); High Mass Impact Resistant - 17.6 oz. projectile from 50" drop

Item #	Lens
EDTSM212	Yellow
EDTSM215	Copper
EDTSM216	Smoke
EDTSMAP218	Aqua Precision Blue Mirror
EDTSM21-G15-7	Silver Mirror

EDGE EYEWEAR

Kazbek Safety Glasses

Polarized



- Black frames wraparound design
- Provide 99.9% protection from UVA, UVB and UVC rays
- High Velocity Impact Resistant - .25" steel ball at 150 ft/s (ANSI); High Mass Impact Resistant - 17.6 oz. projectile from 50" drop

Item #	Lens
EDTSK215	Copper
EDTSK216	Smoke
EDTSKAP218	Aqua Precision Blue Mirror
EDTSK21-G15-7	Silver Mirror

EDGE EYEWEAR

Khor Safety Glasses

Polarized



- Sleek wrap-around frame; no side shield distortion
- Provide 99.9% protection from UVA, UVB and UVC rays
- High Velocity Impact Resistant - .25" steel ball at 150 ft/s (ANSI); High Mass Impact Resistant - 17.6 oz. projectile from 50" drop

Item #	Lens
EDTSDK215	Copper

EDGE EYEWEAR

Reclus Safety Glasses

Polarized



- Black frames wraparound design
- Provide 99.9% protection from UVA, UVB and UVC rays
- High Velocity Impact Resistant - .25" steel ball at 150 ft/s (ANSI); High Mass Impact Resistant - 17.6 oz. projectile from 50" drop

Item #	Lens
EDTSRG216	Gradient

EDGE EYEWEAR

Leash Nylon Cord

- Holds the glasses firmly in place while allowing you to hang them from your neck



Item #
ED9701

EDGE EYEWEAR

Leash Floater Cord

- Holds the glasses firmly in place while allowing you to hang them from your neck



Item #
ED9705



HOWARD LEIGHT BY HONEYWELL

Disposable Foam Earplugs

Multi Max®

Howard Leight

- Uniquely designed two-size-in-one earplug - you have the choice of which tip fits and works best and is most comfortable for you
- Combines high ratings with convenient size flexibility-works for easy inventory
- Smooth, soil-resistant skin features
- Noise reduction rating NRR 31dB
- High-visibility colors, packed in poly bags; 200 pair per box



Item #
HLMM-1

HOWARD LEIGHT BY HONEYWELL

Reusable Earplugs

AirSoft®

Howard Leight

- Advanced air pocket design features internal noise-blocking fins
- Four-flange profile creates better seal in the ear canal
- Less pressure in the ear canal eliminates that "plugged up" feeling
- Rounded flanges, tapered shape fits better in the ear canal; firm stem facilitates easy insertion and removal
- Outstanding noise-blocking protection – highest attenuation in multiple-use



Item #	Desc.	Qty/Box
HLDPAS-1	Uncorded	200 pr
HLDPAS-30R	Corded	100 pr



HOWARD LEIGHT BY HONEYWELL

Reusable Foam Earplugs

Quiet®

Howard Leight



- Features a built-in flexible foam stem which allows wearer to adjust plug for a comfortable fit
- Self-adjusting soft foam eliminates waiting for plug expansion
- Pre-shaped for form fitting protection and exceptional comfort, flared ends makes removal easy
- Washes with soap and water
- Each pair is packaged in convenient plastic reusable flip-top box
- NRR 26 dB
- 100 pair per box

Item #	Desc.
HLQD1	Uncorded
HLQD30	Corded

HOWARD LEIGHT BY HONEYWELL

Disposable Foam Earplugs

Max®

Howard Leight



- Compressible foam rolls up small for easy insertion; expands in ear canal for a custom fit
- Smooth surface for comfort and hygiene
- Preshaped and tapered; soil-resistant skin
- Bright orange-red color
- NRR 33dB

Item #	Desc.	Qty/Box
HLMAX-1	Uncorded	200 pr
HLMAX-30	Corded	100 pr

HOWARD LEIGHT BY HONEYWELL

Disposable Foam Earplugs

Max Lite®

Howard Leight

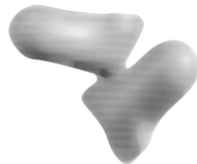

- Reduces noise and eliminates pressure on ear canal
- Smooth surface for comfort and hygiene
- Non-irritating, non-allergenic; preshaped and tapered
- Can be used by wearers with small ear canals; ends flared for easy removal
- Fluorescent green color
- NRR 30dB

Item #	Desc.	Qty/Box
HLLPF-1	Uncorded	200 pr
HLLPF-30	Corded	100 pr

HOWARD LEIGHT BY HONEYWELL

Hearing Bands

Howard Leight

- Smooth, ergonomic pods fit in the ear for maximum protection
- Patented band design prevents ear pods from touching dirty or contaminated surfaces
- Lightweight and portable – designed especially for environments with intermittent noise hazards
- Includes pair of replacement pods



Item #	Type	NRR Rating
HLQB1HYG	Inner Aural	27 dB
HLQB2HYG	Supra Aural	25 dB
HLQB3HYG	Semi Aural	23 dB

Replacement Pods

HLQB100HYG	For QB1HYG
HLQB200HYG	For QB2HYG
HLQB300HYG	For QB3HYG

HOWARD LEIGHT BY HONEYWELL

Noise Blocking Earmuffs

Howard Leight

Leightning®:

- Maximum protection from an ear-muff
- Robust steel headband withstands demanding use
- Padded foam headband and super-soft ear cushions deliver long wearing comfort
- Contemporary design improves wearer compliance
- Telescoping height adjustment



Thunder®:

- Top of the line protection and comfort
- Non-deforming comfort headband fits all head sizes
- Ventilated inner headband and soft pads for maximum comfort
- Quick-Click height adjustment
- Dielectric design safe for electrical environments

Leightning and Thunder feature patented Air Flow Control(TM) technology that improves overall protection without increasing earcup size or weight

Item #	Desc.	Style
HL1010924	Leightning® L3/NRR30	Headband
HL1011997	Leightning® L2F/NRR27	Headband
HL1010970	Thunder® T3/NRR30	Cap Mounted
HL1011603	Thunder® NRR27 T3H	Folding



HOWARD LEIGHT BY HONEYWELL
Noise Blocking Earmuffs

QM24+® Earmuff
Howard Leight



- This 6 oz. dielectric muff is hard to beat during prolonged usage; the high visibility red cups and black band add style to an extremely functional earmuff
- Economical three-position usage, supplied with an adjustable crown strap for a secure fit when worn behind the head or under the chin
- NRR 25 dB when worn over or behind head

Item #
HLQM24+



MOLDEX-METRIC
Ear Plugs
SparkPlugs®



- Uncorded foam earplugs
- NRR33
- 200 pair per box

Item #
MX6604

MOLDEX-METRIC
HandyStrap® Respirators



- HandyStrap® with buckle, allows mask to hang around neck when not in use
- Stretch cloth strap is comfortable against skin; soft foam nose flange for comfort
- Ventex® valve lets hot air out faster
- Size medium/large

Item #	Desc.
MX2600N95	N95 series without valve
MX2700N95	N95 series with valve
MX2800N95	N95 series plus nuisance organic vapors
MX2730N10	N100 series with valve

MOLDEX-METRIC
Disposable Respirators



- Easier to wear, have a pinch-free nose bridge; Dura-Mesh® shell protects the filter media, resists collapsing
- Four elastic straps securely attached
- Size: medium/large

Item #	Desc.
MX2200N95	N95 series without valve
MX2306N95	N95 series with valve

Honeywell

HONEYWELL
Half Mask Respirators



Survivair 2000 Series

- Unique sliding adjustment system on head harness, keeps loose straps secure and out of wearer's vision
- Durable silicone face piece: guaranteed to withstand five years of washings
- Easily convertible and compatible: This half mask converts easily to a belt-mounted Powered Air Purifying Respirator and its replaceable cartridges/filters are compatible with all Survivair half mask and full face piece air purifying respirators

Item #	Size
SRB250000	Small
SRB260000	Medium
SRB270000	Large

HONEYWELL
Half Mask Respirators



Survivair Blue 1™

- Dual flange protection with speaking diaphragm
- Made of comfortable, pliable silicone; the mask will not lose elasticity even in extreme hot or cold weather
- Economical solution for improving wearer communication
- Dual sealing flange provides excellent face piece seal for secure fit
- Easily convertible to Continuous Flow SAR without the aid of tools

Item #	Size
SR210010	Small
SR220010	Medium
SR230010	Large

HONEYWELL
Full Face Respirators



Survivair Opti-Fit™

- Comfortable, durable silicone skirt
- 5-strap suspension headgear
- Nose cup is a standard feature to prevent fogging
- Lens is replaceable and treated with an anti-scratch coating
- Molded in speaking diaphragm

Item #	Size
SR762000	Medium
SR772000	Large



Honeywell

HONEYWELL

Respirator Cartridges

- Accessories for S-Series respirators



Item #	Desc.
--------	-------

Cartridges

SR100100	Organic Vapors (OV)
SR100200	Acid Gases (AG)
SR100844	Multi-Contaminant (MC)

Filters

SR105014	P100 Particulate
SR119044	P100 Slimline
SR106010	N95 Organic Vapor

Accessories

SR140105	P100 Slimline spark cover
SR140171	Filter Retainer
SRB140074	Filter Base

HONEYWELL

Cleaning Wipes

- Wipes do not affect the integrity of the respirator face piece
- Pre-moistened & disposable; reduces the hazard of contamination
- Box includes 100 individually packaged wipes



Item #
SR140096



MEMPHIS GLOVE

Work Gloves

- Cow leather, slip-on cuffs
- Keystone thumb; shirred elastic back
- Select grade



Item #	Size
MG3211-XS	X-Small
MG3211-S	Small
MG3211-M	Medium
MG3211-L	Large
MG3211-XL	X-Large
MG3211-XXL	XX-Large

MEMPHIS GLOVE

Work Gloves

- Cow leather gloves with cotton backs' Gunn pattern select split
- Double leather palm, fleece lining, shirred back
- 2-1/2" rubberized safety cuff



Item #	Size
MG1361	Large

MEMPHIS GLOVE

Work Gloves

Big Jake Series

- Cow leather gloves with cotton backs' Gunn pattern heavy select
- Side leather palm, 8 oz jersey lining, 9 oz. canvas back
- 2-3/4" rubberized cuff
- Sewn w/Kevlar



Item #	Size
MG1700L	Large
MG1700XL	Extra Large

MEMPHIS GLOVE

Work Gloves

Arctic Jack® Series

- Thinsulate® lining
- Grain pigskin



Item #	Desc.	Size
MG1965-L	2 1/2" Safety Cuff	Large
MG1966-L	Knit wrist	3Large

MEMPHIS GLOVE

Insulated Driver's Gloves

- Premium grain pigskin Thinsulate® lined
- Keystone thumb



Item #	Size
MG3460-S	Small
MG3460-M	Medium
MG3460-L	Large
MG3460-XL	X-Large

MEMPHIS GLOVE

Deerskin Driver's Gloves

- Red jersey lined; self hemmed
- Keystone thumb; split deer back grain deer palm



Item #	Size
MG3555-M	Medium
MG3555-L	Large
MG3555-XL	X-Large



MEMPHIS GLOVE
Welder's Gloves

Bob Cat™

- Select side cow leather; Gunn pattern brown
- Straight thumb w/reinforcement; grey cuff w/flame-resistant cuff liner
- Sewn w/Kevlar



Item #	Size
MG4740	Large

MEMPHIS GLOVE
Cotton Gloves

- 8 oz. cotton canvas
- 2.5" knit wrist
- Straight thumb; clute pattern



Item #
MG8100C

MEMPHIS GLOVE
Cotton Gloves

Dotted Palm

- 8 oz. regular weight cotton canvas
- PVC dotted palm, index finger and thumb
- 2.5" knit wrist
- Straight thumb; clute pattern



Item #	Size
MG8802	Small
MG8808	Large

MEMPHIS GLOVE
String-Knit Gloves

- Cotton/Polyester blend; 7 gauge regular weight
- Natural color, hemmed



Item #	Size
MG9500XSM	Extra Small
MG9500MM	Medium
MG9500LM	Large

MEMPHIS GLOVE
String-Knit Gloves

Thermostat™

- Blue, 10 gauge, 100% thermostat
- One Size Fits All



Item #
MG9622

MEMPHIS GLOVE
Jersey Gloves

- Cotton brown jersey
- Knit wrist; straight thumb
- Clute cut
- 7100P - 100% cotton



Item #	Size
MG7102	Small
MG7100P	Large

MEMPHIS GLOVE
Powdered Vinyl Gloves

SensaGuard™

- Industrial Grade - Blue; 5 mil thickness
- Ambidextrous w/rolled cuffs
- Component materials comply with FDA regulations for food contact
- 100 gloves per dispenser



Item #	Size
MG5030-L	Large
MG5030-XL	X-Large

MEMPHIS GLOVE
Powder Free Latex Gloves

Med-Tech™

- 11 mil thickness
- Component materials comply with FDA regulations for food contact
- Ambidextrous w/rolled cuffs
- 12" Length
- 50 gloves per dispenser



Item #	Size
MG5049-L	Large

MEMPHIS GLOVE
PVC Gloves

- Double dipped black PVC
- Sandpaper finish



Item #	Size	Liner	Style
MG6100S	Large	Interlock	3" knit wrist
MG6212SJ	Large	Jersey	12" gauntlet

MEMPHIS GLOVE
PVC Gloves

- Double dipped red PVC
- Jersey liner, sandpaper finish
- 14" Gauntlet



Item #
MG6454S



MEMPHIS GLOVE
PVC Gloves

- Double dipped black PVC
- Jersey lining, rough finish
- 14" Gauntlet

Item #
MG6514SJ



MEMPHIS GLOVE
Latex Gloves

- 18 Mil blue canners
- Unlined, straight cuff

Item #	Size
MG5199B	10.5



MEMPHIS GLOVE
Latex Gloves

- 18 Mil yellow canners
- Unlined, straight cuff

Item #	Size
MG5199E	10.5



MEMPHIS GLOVE
Nitrile Gloves

Nitri-Chem

- 11 Mil thick
- Green nitrile gloves, unlined
- Straight cuff, pebble embossed grip

Item #	Size
MG5308	8 (Men's Small)
MG5309	9 (Men's Large)
MG5310	10 (Men's XL)



Honeywell

HONEYWELL
Perfect-Coat™

- 10 Cut, medium weight; outstanding abrasion resistance
- Gray cotton/polyester shell with blue natural rubber palm and fingertip coating

Item #	Size
PFG300PC-S	Small
PFG300PC-M	Medium
PFG300PC-L	Large
PFG300PC-XL	Extra Large



HONEYWELL
Pure Fit™ Gloves

- 13 Cut, lightweight white nylon shell with gray foamed nitrile palm coating; lightweight knit enhances ventilation to keep hands cool and dry
- Lightweight fibers provide superior tactile sensitivity for precision handling and delicate operations
- Filament yarn reduces linting and is easily laundered for extended use

Item #	Size
PFG390-S	Small
PFG390-M	Medium
PFG390-L	Large
PFG390-XL	Extra Large



HONEYWELL
Perfect-Coat0™

- Heavyweight light gray cotton/polyester napped knit shell with gray natural rubber palm and fingertip coating; outstanding abrasion resistance

Item #	Size
PFG451PC-S	Small
PFG451PC-M	Medium
PFG451PC-L	Large
PFG451PC-XL	Extra Large



HONEYWELL
Pure-Fit™

- 13 Cut, lightweight charcoal HPPE shell liner with gray polyurethane palm and fingertip coating
- Combination of HPPE fiber with nitrile palm coating offers increased cut resistance and superior abrasion resistance

Item #	Size
PFG541-L	Large
PFG541-XL	Extra Large



Ansell

ORS-NASCO
HyFlex®

Dyneema® and LYCRA® liner

- Relaxed, natural fit liner helps reduce hand fatigue
- Polyurethane coating and liner combination; improves tactile sensitivity
- Excellent grip in dry environments; effective control in minimally oily environments
- Cool and comfortable feeling; launderable, durable materials

Item #	Size
OR11-627-8	8
OR11-627-9	9
OR11-627-10	10
OR11-627-11	11





MAJESTIC GLOVE
Cut Resistant Gloves

- Dyneema continuous fiber
- 13 gauge seamless knit
- White polyurethane palm coating
- Cut resistance equivalent to kevlar with ten times greater abrasion resistance



Item #	Size
MJ3435-M	Medium
MJ3435-L	Large
MJ3435-XL	Extra large



CUSTOM LEATHERCRAFT
Handyman™ Work Gloves

- Clarino® synthetic leather is tough, soft and comfortable to wear, resists shrinking, stretching and hardening
- Padded knuckles provide protection against bumps
- Lycra side panels for improved dexterity
- Padded palm for more comfort
- Elastic wrist cuff keeps debris out
- Reinforced fingertips for added durability



Item #	Size
CS125M	Medium
CS125L	Large
CS125XL	X-Large

CUSTOM LEATHERCRAFT
Boxer™ Work Gloves

- Clarino® synthetic leather is tough, soft and comfortable to wear, resists shrinking, stretching and hardening
- Padded knuckles provide protection against bumps
- Lycra side panels for improved dexterity
- Non-slip fourchette for reinforced extra grip on index and thumb fingers
- Elastic wrist cuff keeps debris out
- Tacky pattern on palm and fingers for a firm non-slip grip
- Terry cloth on thumbs to remove sweat or debris from face



Item #	Size
CS135M	Medium
CS135L	Large
CS135XL	X-Large

CUSTOM LEATHERCRAFT
Pro Framer™ Work Gloves

- Clarino® synthetic leather is tough, soft and comfortable to wear, resists shrinking, stretching and hardening
- Padded knuckles provide protection against bumps; textured grip palm pads for better grip, extra wear and added durability
- Wing closing strap for perfect adjustments and easy-on, easy-off; flexible neoprene wrist cuff keeps debris out
- Stretch spandex for flexibility and fit; Lycra side panels for improved dexterity
- Flex-Spot™ thumb design for better flexibility; terry cloth on thumbs to remove sweat or debris from face



Item #	Size
CS140M	Medium
CS140L	Large
CS140XL	X-Large

CUSTOM LEATHERCRAFT
Tradesman™ Work Gloves

- Clarino® synthetic leather is tough, soft and comfortable to wear, resists shrinking, stretching and hardening
- Padded knuckles provide protection against bumps; textured grip palm pads for better grip, extra wear and added durability
- Wing closing strap for perfect adjustments and easy-on, easy-off; flexible neoprene wrist cuff keeps debris out
- Stretch spandex for flexibility and fit; Lycra side panels for improved dexterity
- Flex-Spot™ thumb design for better flexibility; terry cloth on thumbs to remove sweat or debris from face



Item #	Size
CS145M	Medium
CS145L	Large
CS145XL	X-Large

CUSTOM LEATHERCRAFT
Safety Tradesman™ Work Gloves

Hi-Vis

- Wing closing wrist strap for perfect adjustments and easy-on, easy-off
- Clarino® synthetic leather palms, tough, soft and comfortable to wear, resists shrinking, stretching and hardening
- Textured grip palm pads for better grip, extra wear and durability; neoprene knuckle provides padding against bumps
- Flex-Spot™ thumb design for better flexibility; terry cloth on thumbs to remove sweat or debris from face
- Stretch Spandex for flexibility and fit; Lycra side panels for improved dexterity
- Safety orange with black and yellow accents



Item #	Size
CS147M	Medium
CS147L	Large
CS147XL	X-Large



CUSTOM LEATHERCRAFT
Storm™ Work Gloves

- Clarino® synthetic leather is tough, soft and comfortable to wear, resists shrinking, stretching and hardening
- Neoprene knuckles provide padding against bumps; Clarino® non-slip pads for tough grip, extra wear and added durability
- Hook and loop closure strap for comfort and protection from cold temperatures
- Stretch spandex with a Reissa® membrane coating is wind, rain and snow resistant; Lycra side panels for improved dexterity
- Terry cloth to remove sweat or debris from face



Item #	Size
CS170M	Medium
CS170L	Large
CS170XL	X-Large

CUSTOM LEATHERCRAFT
Demolition™ Work Gloves

- Top grain leather palm; tough, soft, and comfortable
- Molded cap TPR knuckles provide padding against bumps
- Wing closing strap for perfect adjustments and easy-on, easy-off
- Sandwich mesh for breathable flexibility and fit; Spandex side panels for improved dexterity
- PU Carbon fiber palm pads for better grip and added durability; flexible neoprene wrist cuff keeps debris out
- Terry cloth to remove sweat or debris from face



Item #	Size
CS175M	Medium
CS175L	Large
CS175XL	X-Large

CUSTOM LEATHERCRAFT
Airflow™ Work Gloves

- Clarino® synthetic leather is tough, soft and comfortable to wear, resists shrinking, stretching and hardening
- Padded knuckle provide protection against bumps
- Wing closing strap for perfect adjustments and easy-on, easy-off
- Air mesh for maximum breathability, flexibility and fit; Lycra side panels for improved dexterity
- Sure Grip™ on palm and fingers for a firm non-slip grip; flexible neoprene wrist cuff keeps debris out
- Terry cloth to remove sweat or debris from face



Item #	Size
CS190M	Medium
CS190L	Large
CS190XL	X-Large

CUSTOM LEATHERCRAFT
Backcountry™ Work Gloves

Mossy Oak®

- Clarino® synthetic leather is tough, soft and comfortable to wear, resists shrinking, stretching and hardening
- Padded knuckles provide protection against bumps
- Wing closing strap for perfect adjustments and easy-on, easy-off
- Stretch spandex for flexibility and fit; Lycra side panels for improved dexterity
- Padded palm and fingers for more comfort; elastic wrist cuff keeps debris out



Item #	Size
CSM125M	Medium
CSM125L	Large
CSM125XL	X-Large



YAKTRAX®
Outdoor Performance Footcare

**Traction Device
PRO**

- High-strength, abrasion resistant 1.4 mm steel coils
- Heavy-duty natural rubber material
- Provides 360 degrees of traction on packed snow and ice and can be worn in temperatures as low as -41° Fahrenheit
- Easy On/Off
- Walk naturally
- Spikeless/Ultralight
- Helps reduce the risk of falls & injuries



Item #	Size	Womens	Mens
YA08009	Sml	5-8½	6½-10
YA08011	Med	9-11	10½-12½
YA08013	Lrg	11½-13½	13-15
YA08015	XL	14+	15½+

**Keep your
workforce safe.
Try the Yaktrax
on ice and snow.**

JACKSON

KIMBERLY CLARK Safety T-Shirts Jackson Safety



- Chest pocket with continuous super bright silver retroreflective tape
- Ribbed collar & cuffs with a stitched hem for added comfort & durability; Polyester moisture management fabric wicks away excess moisture
- Meets ANSI/ISEA 107 - 2004 Class 2 standards

Item #	Size
Lime	
JS3012947	L
JS3012948	XL
JS3012949	2X
Orange	
JS3012943	L
JS3012944	XL
JS3012945	2X

KIMBERLY CLARK Safety Vests

ESK Reflective Jackson Safety



- Mesh fabric, one size fits most
- Elastic sides for easy fit, hook and loop closure

Item #	Desc.
JS3017589	Orange, 3/4" lime prismatic
JS3017593	Lime, 1 1/2" orange on lime

KIMBERLY CLARK Safety Vests

ESK Non-Reflective Jackson Safety



- Mesh fabric, one size fits most
- Elastic sides for easy fit, hook and loop closure

Item #	Color
JS3017585	Orange
JS3017586	Lime

KIMBERLY CLARK Safety Vests

GPV Reflective Jackson Safety



- Constructed of flat weave, 7 oz. polyester
- Can be wiped clean

Item #	Desc.
JS3006273	Orange w/ Lime Stripes

KIMBERLY CLARK Safety Vests

Survey - Class 2 Jackson Safety



- 4 pocket design (2 exterior and 2 interior)
- 360 degree visibility with high intensity tape, machine washable; color prismatic reflective tape
- Meets ANSI / ISEA 107 - 2004 Class 2 standards

Item #	Size	Desc.
JS3022275	M/Lg	Orange w/Lime Prismatic
JS3022276	XL/2X	Orange w/Lime Prismatic
JS3022277	3X/4X	Orange w/Lime Prismatic
JS3022278	M/Lg	Lime w/Orange Prismatic
JS3022279	XL/2X	Lime w/Orange Prismatic
JS3022280	3X/4X	Lime w/Orange Prismatic

KIMBERLY CLARK Safety Vests

Survey Vests - Class 3 Jackson Safety



- 4 pocket design (2 exterior and 2 interior)
- 360 degree visibility with high intensity tape, machine washable; color prismatic reflective tape
- Meets ANSI/ISEA 107 - 2004 Class 3 standard

Item #	Size	Desc.
JS3022337	M/Lg	Orange w/Lime Prismatic
JS3022338	XL/2X	Orange w/Lime Prismatic
JS3022339	3X/4X	Orange w/Lime Prismatic
JS3022340	M/Lg	Lime w/Orange Prismatic
JS3022341	XL/2X	Lime w/Orange Prismatic
JS3022342	3X/4X	Lime w/Orange Prismatic



RADIANS Economy Surveyor Vest

Class 2



- Reflective stripes on contrasting trim make workers much more noticeable in low-light and broad daylight
- Specifications:

- Closure: Zipper; Pockets: 2
- Tape: 2" Silver reflective material w/1 horizontal stripe
- Materials: 100% polyester mesh

Item #	Size	Color
RVSV22-2ZGM-L	Large	Hi-Vis Green
RVSV22-2ZGM-XL	X-Large	Hi-Vis Green



RADIANS
Surveyor Vest

Class 2



- Reflective stripes on contrasting trim make workers much more noticeable in low-light and broad daylight; mic tab on both shoulders

Specifications:

- Closure: Zipper; Pockets: 7
- Tape: 2" silver reflective material w/1 horizontal stripe
- Materials: 100% polyester solid knit/twill front, 100% polyester mesh back

Item #	Size	Color
RVSV6G-M	Medium	Hi-Vis Green
RVSV6G-L	Large	Hi-Vis Green
RVSV6G-XL	X-Large	Hi-Vis Green
RVSV6G-2XL	XX-Large	Hi-Vis Green

RADIANS
Surveyor Vest

Class 2



- Radio pocket and lower front pockets are covered; inside pockets are extra deep to prevent tools, phones, or radios from falling out; mic tab on both shoulders

Specifications:

- Closure: Zipper; Pockets: 7
- Tape: 2" silver reflective material w/1 horizontal stripe
- Materials: 100% polyester solid knit front, 100% polyester mesh back

Item #	Size	Color
RVSV70-L	Large	Hi-Vis Orange
RVSV70-XL	X-Large	Hi-Vis Orange
RVSV70-2XL	XX-Large	Hi-Vis Orange

RADIANS
Surveyor Vest

Class 3



- Contrast trim combinations make workers much more noticeable in low light and broad daylight ; mic tab on both shoulders

Specifications:

- Closure: Zipper; Pockets: 7
- Tape: 2" silver reflective material w/1 horizontal stripe
- Materials: 100% polyester solid knit front, 100% polyester mesh back, 100% polyester mesh sleeves

Item #	Size	Color
RVSVS63G-L	Large	Hi-Vis Green
RVSVS63G-XL	X-Large	Hi-Vis Green
RVSVS63G-2XL	XX-Large	Hi-Vis Green

RADIANS

Two-In-One Bomber Jacket

- Zip out removable fleece jacket; concealed detachable hood
- Tape: 2" silver high visibility reflective tape
- Mic tabs on both shoulders
- Clear, chest badge holder; fleece lined chest pocket
- Pockets: 8
- Materials: PU coated polyester waterproof shell
- Elastic waistband
- Elastic wrist cuffs with hook & loops closures



Item #	Size	Color
RVSJ21-3ZGS-L	Large	Hi-Vis Green
RVSJ21-3ZGS-XL	X-Large	Hi-Vis Green
RVSJ21-3ZGS-2X	XX-Large	Hi-Vis Green
RVSJ21-3ZGS-3X	XXX-Large	Hi-Vis Green

RADIANS

Three-In-One Weatherproof Parka

- Wind and water resistant shell; removable inner fleece jacket; concealed hood
- Tape: 2" silver reflective tape
- Mic tabs on both shoulders
- Pockets: 8
- Fleece lined chest pocket
- Pass through on back for fall protection
- Wrist cuffs with closure



Item #	Size	Color
RVSJ41-3ZGS-L	Large	Hi-Vis Green
RVSJ41-3ZGS-XL	X-Large	Hi-Vis Green
RVSJ41-3ZGS-2X	XX-Large	Hi-Vis Green
RVSJ41-3ZGS-3X	XXX-Large	Hi-Vis Green



CUSTOM LEATHERCRAFT

Class 3 Certified Rainsuit

- 3 Piece - Consists of hood, jacket and bib overalls
- High quality polyester reflective material
- Storm front jacket with zippered closure
- When worn as a suit – meets all ANSI CLASS 3 high visibility criteria



Item #	Size
CSR111L	Large
CSR111X	X-Large
CSR1112X	XX-Large



CUSTOM LEATHERCRAFT
Fluorescent Yellow Rain Suit

- High visibility material
- Full cut sizes to fit over clothing
- Jacket, bib pants and detachable hood
- Storm front jacket with double fly snap
- Heavy duty buckles on overall straps
- Rear mesh vents for breathability
- Constructed with durable water resistant Oxford Polyester



Item #	Size
CSR107L	Large
CSR107X	X-Large
CSR1072X	XX-Large

CUSTOM LEATHERCRAFT
Black PVC Boot

Plain Toe

- Cleated outsole
- Over the sock



Item #	Size
CSR23010	10
CSR23011	11
CSR23012	12

**Need other
raingear or
workwear?**

**Call Edge
Today.**



HELLY HANSEN
Hi Vis Polyester W/PU Backed Rainwear

Alta Jacket and Pant

- COLORS: 360 EN471 Yellow, 260 EN471 Orange
- SIZES: S-3XL
- 100 % Polyester, PU coated, 150 g/m
- Lining 100% Nylon



Jacket Details:

- Insulation 100% polyester, 120 g in body, 80 g in sleeve
- Reflective tape EN 471- Class 3 EN 343- 3,1 EN 342
- Packable Hood with drawcord at front, Velcro at back
- Fleece inside collar
- Chin guard w/ fleece & printed logo
- Front zipper w/ storm flap
- Inner chest pocket

Pant Details:

- Insulation 100% polyester, 80 g
- Reflective tape
- Elastic waist
- Inside kneepad pockets
- Boot zipper and velcro adjustment at hem
- Loop inside waist for ID card
- Printed logo at hip
- EN 471- Class 2 EN 343- 3,1 EN 342

Item #	Color
--------	-------

Alta Jacket

HH70333-260FL	Orange
HH70333-360FL	Yellow

Alta Pant

HH70444-260FL	Orange
HH70444-360FL	Yellow



HELLY HANSEN

High Vis PU Coated Polyester Raincoat

Narvik

High Viz "Patrol" jacket with 3M reflective tape that enjoys a degree of stretch you will not find in many other jacket styles

- PU Coated Knitted Polyester - 180g Light Weight
- Stretchable fabric
- Waterproof
- Reflective 3M® Scotchlite stripes on chest and arms
- Storm flap with zip and Velcro closure
- 2 hand pockets with flap
- Concealed hood in collar
- Draw cord adjustment on hood
- Inside rib cuff; Velcro closure at sleeves
- Draw cord adjustment on bottom hem



Item #	Color
HH70260-260	EN471 Orange
HH70260-360	EN471 Yellow

HELLY HANSEN

Flame Retardant Base Layer

Fargo

FR Bodywear is comprised of a woven 230g blend of Kermel®, Viscose and Beltron Antistatic, to provide warmth and moisture management.

Crewneck and Pant Features:

- Anti-static; highly resistant to abrasion
- Moisture removing material
- Flatlock seams
- Double knit cuffs
- ASTM-F1891-06 Compliant

Balaclava Features:

- Ribbed expandable face opening
- Anti-static; highly resistant to abrasion
- Moisture removing material
- Flatlock seams
- ASTM-F1891-06 Compliant
- Crewneck and pants available in sizes XS-4XL
- Balaclava is one size fits all



Item #	Description	Color
HH75090-560	Crewneck Shirt	Royal Blue
HH75490-560	Pant	Royal Blue
HH79892-560	Balaclava	Royal Blue

HELLY HANSEN

Flame Retardant Midlayer

FR Softpile™

FR SoftPile™ is a blend of Kermel®, Wool, Lenzing and Beltron Antistatic to provide warmth and protection.

Jacket Features:

- 410g blend of Kermel®, Wool, Lenzing and Beltron fleece knit
- Anti-static
- Soft hand and ultra warm
- Front Nomex® / brass zipper closure with inner storm flap
- Reinforced zipper and collar edge with FR binding
- High collar design
- Drawcord adjustable hood
- Two side seam pockets
- Flatlock seams
- FR knit cuffs at wrist
- ASTM-F1891-06 Compliant



Pant Features:

- 410g blend of Kermel®, Wool, Lenzing and Beltron fleece knit
- Anti-static
- Soft hand and ultra warm
- Enclosed elastic hem waist
- Flatlock seams
- FR knit cuffs at wrist
- ASTM-F1891-06 Compliant

Item #	Description	Color
HH72190-960	Jacket	Grey
HH72191-960	Hooded Jacket	Grey
HH72490-960	Pant	Grey

HELLY HANSEN

Barcelona Soft Shell Jacket

- 95% Polyester, 5% Elastane
- Reflective piping at elbows and shoulder in front and back
- Available in Black (990) or Black/Dark Grey (999)



Item #	Size
HH74008XS	Extra Small
HH74008S	Small
HH74008M	Medium
HH74008L	Large
HH74008XL	Extra-Large
HH740082XL	2XL
HH740083XL	3XL
HH740084XL	4XL



HELLY HANSEN
Highliner Jacket

- PVC-coated woven cotton, 450g heavy weight; .45 mm thick
- Oil-, chemical-, and cold-resistant
- Available in Light Yellow (310) and Dark Green (490)



Item #	Size
HH70300XS	Extra Small
HH70300S	Small
HH70300M	Medium
HH70300L	Large
HH70300XL	Extra Large
HH703002XL	2XL
HH703003XL	3XL
HH703004XL	4XL

HELLY HANSEN
Highliner Bib

- PVC-coated woven cotton, 450g heavy weight; .45 mm thick
- Oil-, chemical-, and cold-resistant
- Available in Light Yellow (310) and Dark Green (490)



Item #	Size
HH70300XS	Extra Small
HH70300S	Small
HH70300M	Medium
HH70300L	Large
HH70300XL	Extra Large
HH703002XL	2XL
HH703003XL	3XL
HH703004XL	4XL



KIMBERLY-CLARK
Protective Coveralls
KleenGuard® A40

- Zipper front; elastic wrists & ankles
- White in color
- Low in lint; made with breathable material for comfort
- Meets ANSI/ISEA 101-1996 sizing standard
- Passes NFPA 99 criteria for antistatic materials



Item #	Size
KC44314	XL
KC44315	XXL

KIMBERLY-CLARK
Protective Coveralls
KleenGuard® A40



- Zipper front; elastic wrists, ankles & hood
- Low in lint; made with breathable material for comfort
- White in color; meets ANSI/ISEA 101-1996 sizing standard
- Passes NFPA 99 criteria for antistatic materials

Item #	Size
KC44322	Med
KC44323	Lrg
KC44324	XL
KC44325	XXL
KC44326	XXXL

KIMBERLY-CLARK
Shop Towels
WypAll® X80

- Red in color; absorbs more oil and water faster pound for pound than laundered shop towels
- No holes, strings, metal chips or residues like laundered shop towels; maintains strength in solvents as well as laundered shop towels
- Can be used for heavy-duty & part wiping, wiping metal shavings, prepping surfaces with solvents, cleaning rough surfaces
- Size: 12.5" x 13.4"; 475 per roll



Item #
KC41055



KIMBERLY CLARK
Traffic Cones

W Series
Jackson Safety

- Meets MUTCD standards with orange base

Item #	Desc.
JS3004019	12" - 2 lbs.
JS3004042	18" - 2.5 lbs.
JS3004158	28" - 6.5 lbs.



KIMBERLY CLARK
Traffic Cones

DW Series
Jackson Safety

- Meets MUTCD standards; wide body design with rugged black base
- Flow molded, dayglow orange PVC w/white inner liner; 6" & 4" reflective collars

Item #	Desc.
JS3004205	28" - 7 lbs.





KIMBERLY CLARK
Delineator Posts
Jackson Safety

- NCHRP-350 approved
- Two 3" reflective bands standard
- Standard 4" x 42" high post;; 16" W x 11/2" H octa-
gon base 10 lb.

Item #	Desc.
JS3007642	Post
JS3001742	Base



KIMBERLY CLARK
Safety Triangles
Jackson Safety

- Meets FMVSS-125 standards
- Polypropylene plastic with red acrylic plastic reflectors; air-flow design helps reduce wind resistance
- Kit includes - 3 triangles in poly box

Item #
JS3006007



KIMBERLY CLARK
Traffic Paddles
Jackson Safety

- .080 gauge baked aluminum enamel
- Aluminum silk-screened octagon shaped paddles in 18" size
- Ideal for school crossing guards, flaggers, & plant security guards

Item #	Desc.
JS3007354	18" wood handle
JS3007641	6" wood handle

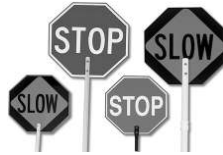

KIMBERLY CLARK
Pennant Flag
Jackson Safety

- Made of low density UV polyethylene for long lasting use
- Tensile strength of 107 lbs. for extra durability
- 9"x13" red triangular pennants, 100' long

Item #
JS3006634



KIMBERLY CLARK
Warning Flags
Jackson Safety

- Orange vinyl 18" flag with 24" dowel
- Heat sealed hem

Item #
JS3006648



KIMBERLY CLARK
Speed Bumps
Jackson Safety

- Withstands 120,000 lbs., will not warp, crack, chip or rot, made of 100% recycled rubber
- Yellow polyurethane glass-beaded paint for maximum reflectivity
- Channeled bottom (two 1/4" channels) allows for cabling or piping and facilitates drainage
- Four spikes required on 72" speed bumps, spikes sold separately
- Striped Seed Bump 2.5" X 12" X 72"

Item #
JS3007917



KIMBERLY CLARK
Parking Curbs
Jackson Safety

- Manufactured from 100% recycled rubber, will not warp, crack, chip or rot
- Yellow polyurethane glass-beaded paint for maximum reflectivity
- 1/10 the weight of concrete
- Resistant to UV, moisture, oil and extreme temperature variations
- Two spikes required on 36", four spikes on 72" parking curbs. Spikes sold separately

Item #	Desc.
JS3007914	Parking Curb 4 in. x 6 in. x 36 in.
JS3007915	Parking Curb 4 in. x 6 in. x 72 in.

Rebar Spikes

JS3007973	14 in. Rebar Spikes
-----------	---------------------



KIMBERLY CLARK
Wheel Chock
Jackson Safety

- Built to meet OSHA requirements
- Designed for maximum traction on practically any surface, wet or dry
- Fluted design causes downward pressure to lock chock into place
- Rubber with imbedded metal O-hook

Item #
JS3006598



KIMBERLY CLARK
Sandbags
Jackson Safety

- Hemmed top polypropylene sand-bag, tie cord attached
- UV Rating: 500 hrs.
- White, 14x26 in.
- 100 per bundle

Item #
JS3006693





CERTIFIED SAFETY MANUFACTURING INC.
10-Person First Aid Kit

Contents:

- Certi-Strips - Plastic - 1"x3"- ANSI Z308.1 2009 - 16/unit
- Certi-Gauze Pads - 3"x3" - ANSI Z308.1 2009 - 4/unit
- Certi-Burn Cream - 1 gm. - ANSI Z308.1 2009 - 6/unit
- Antiseptic BZK - Towelettes - 5"x7" - ANSI Z308.1 2009 - 10/unit
- Triangular Bandage O/W - 40"x40"x56" - ANSI Z308.1 2009 - 3 ea.
- Gloves - Nitrile - ANSI Z308.1 2009 - 1 pair
- Certi-Tape - 1/2"x2-1/2 yd. - ANSI Z308.1 2009 - 1 ea.
- Certi-Strip - Woven - Medium Fingertip - 1 ea.
- Certi-Strip - Woven - Knuckle - 1 ea.
- First Aid Facts Sheet - 6"x16" - 1 ea.



Item #	Desc.
CFK610-027	Poly Case
CFK610-028	Metal Case

CERTIFIED SAFETY MANUFACTURING INC.
25-Person First Aid Kit

Contents:

- Certi-Strips - Plastic - 1"x3"- ANSI Z308.1 2009 - 16/unit
- Certi-Gauze Pads - 3"x3" - ANSI Z308.1 2009 - 4/unit
- Certi-Burn Cream - 1 gm. - ANSI Z308.1 2009 - 6/unit
- Antiseptic BZK - Towelettes - 5"x7" - ANSI Z308.1 2009 - 10/unit
- Certi-Strip - Woven - Fingertip & Knuckle - 9/unit
- Gloves - Nitrile - ANSI Z308.1 2009 - 1 pair
- Certi-Tape - 1/2"x2-1/2 yd. - ANSI Z308.1 2009 - 1 ea.
- Cold Pack - Certi-Cool - Junior - 1 ea.
- Ammonia Inhalant - 1 ea.
- Eye Wash - 4 oz. - ANSI Z308.1 2009 1 ea.
- First Aid Facts Sheet - 6"x16" - 1 ea.



Item #	Desc.
CFK610-029	Poly Case
CFK610-030	Metal Case

CERTIFIED SAFETY MANUFACTURING INC.
50-Person First Aid Kit

Contents:

- Certi-Gauze Pads - 3"x3" - ANSI Z308.1 2009 - 4/unit
- Certi-Burn Cream - 1 gm. - ANSI Z308.1 2009 - 6/unit
- Antiseptic BZK - Towelettes - 5"x7" - ANSI Z308.1 2009 - 10/unit
- Eye Pads - Certi-Tape - Oval - 8/unit
- Certi-Strip - Plastic - Assortment - ANSI Z308.1 2009- 75/asst.
- Triangular Bandage O/W - 40"x40"x56" - ANSI Z308.1 2009 - 3 ea.
- Gloves - Nitrile - ANSI Z308.1 2009 - 1 pair
- Certi-Tape - 1/2"x2-1/2 yd. - ANSI Z308.1 2009 - 1 ea.
- Certi-Gauze Roll - 2"x6 yd. - 1 ea.
- Cold Pack - Certi-Cool - Junior - 1 ea.
- Certi-Gauze - Non-Stick Pad - 2"x3" - 1 ea.
- Ammonia Inhalant - 1 ea.
- PVP Iodine Wipe-Ups - 1"x2" - 1 ea.
- Eye Wash - 4 oz. - ANSI Z308.1 2009 - 1 ea.
- Elastic Bandage - Ace Style - 2" x 5 yd. - 1 ea.
- Forceps - Plastic - 4" - 1 ea.
- First Aid Facts Sheet - 6"x16" - 1 ea.



Item #	Desc.
CFK610-033	Poly Case



RUBBERMAID COMMERCIAL PRODUCTS
Water Coolers

Gott®

- Durable construction resists scratching, denting and fading
- Drip-resistant spigot; screw-tight lid
- Extra-thick insulation ensures superior thermal retention
- Stain and odor resistant, easy-to-clean liner
- Swing-top bail handle for easy carrying



Item #	Size (gal.)
IGGT1683	3
IGGT1685	5
IGGT1610	10

RUBBERMAID COMMERCIAL PRODUCTS
Mounting Bracket

- Designed specifically for Rubbermaid® water coolers
- Durable, weather-resistant construction
- Horizontal mounting



Item #	Desc.
IGGT1640	Rack



RUBBERMAID COMMERCIAL PRODUCTS

Cup Holder

- Designed specifically for Rubbermaid® water coolers
- Durable, weather-resistant construction



Item #
IGGT8257UN

RUBBERMAID COMMERCIAL PRODUCTS

Paper Cone Cup

Solo®

- 4 oz. cone shaped water cup with a rolled rim
- 25 sleeves of 200; 5000 cups per case



Item #
IG9346



THE SQWINCHER CORP.
Electrolyte Drinks

Ready-To-Drink Bottles

- Ready-to-drink; 20 oz. wide-mouth plastic bottle
- 24 per case

Item #	Flavor
SQ030530-BE	Berry
SQ030531-CI	Citrus
SQ030532-GR	Grape
SQ030534-OR	Orange
SQ030535-FP	Fruit Punch



THE SQWINCHER CORP.
Electrolyte Drinks

Fast Pack®

- This package is your cup for a handy single-serving of 6 oz. when water is added
- 4/50 pk. per case

Item #	Flavor
SQ015301-CH	Cherry
SQ015302-GR	Grape
SQ015303-LA	Lemonade
SQ015304-OR	Orange
SQ015305-FP	Fruit Punch
SQ015308-LL	Lemon-Lime



THE SQWINCHER CORP.
Electrolyte Drinks

Qwik Stik

- Pour in 20 oz. bottle of water
- 10/50 pk. per case

Item #	Flavor
SQ060100-OR	Orange
SQ060102-FP	Fruit Punch
SQ060106-LL	Lemon Lime
SQ060107-GR	Grape



THE SQWINCHER CORP.
Electrolyte Drinks

Powder Pack™

- Powder pack makes 2.5 gallons
- 32 pk. per case

Item #	Flavor
SQ016040-LA	Lemonade
SQ016041-OR	Orange
SQ016042-FP	Fruit Punch
SQ016043-LL	Lemon-Lime
SQ016046-GR	Grape



MOTOROLA
Two-Way Radios

RDX Series

4 watt two-way radio operates on an innovative 89 business-exclusive UHF frequencies.

- Exceptional voice quality
- Rugged and water-resistant
- Customer programming software
- Simplified cloning
- Voice activation



Item #	Frequency Band	Coverage Area
MOTRDU4100	UHF	Up to 350,000 sq. ft. 30 floors

MOTOROLA
High Capacity Lithium Ion Battery

Item #	Radio Compatibility
MOTRLN6305	RDX Series





MOTOROLA
Standard Capacity Lithium Ion Battery

Item #	Radio Compatibility
MOTRLN6351	RDX Series



MOTOROLA

Multi-Unit Charger

- Charges up to 6 radios at a time

Item #	Radio Compatibility
MOTRLN6309	RDX Series



MOTOROLA

External Speaker Microphones

This clip-on microphone allows to talk and listen without reaching for radio

- For: XU-XV Series; Spirit M-Series, SP10

Item #
MOT53862



MOTOROLA

Extreme Headset

- Can be worn with most protective headgear, bumpcaps, and hardhats
- Shell mounted push to talk button

Item #
MOTXTI



MOTOROLA

CPS USB Programming Cable

- Used to further enhance the productivity benefits from Motorola RDX Series radios

Item #	Radio Compatibility
MOTRKN4155	RDX Series



Honeywell

HONEYWELL

Eyewash Bottles

- Buffered, saline solution that is sterile
- FDA grade polyethylene bottles are tamper-resistant



Item #	Desc.
UV32-000451-0000	1 oz. with user-controlled delivery
UV32-000455-0000	16 oz. with extended flow nozzle

HONEYWELL

Eyewash Station

- Durable, open-face design holds bottle firmly in place
- Mounts to wall with provided screws
- Easy to clean durable plastic
- Holds one 32 oz. bottle of sealed, sterile saline



Item #
UV32-000461-0000



LOGISTICS

Purell® Hand Sanitizer

- Kills 99.9% of most common germs
- Works in as little as 15 seconds
- No water or towels needed
- Alcohol based

Item #	Size
GJ9652-12	8 oz. pump



NATIONAL MARKER CO.

Jobsite Safety Signs

10" X 14" Rigid Plastic

- Prevent injuries, OSHA violations and penalties, post safety signs throughout your facility
- These visual reminders provide for a safe and more efficient work environment



Item #	Desc.
NMC151RB	Caution, Eye and Ear Protection Required in This Area
NMD125RB	Danger Men Working Above
NMD132RB	Danger Construction Area
NMD247RB	Danger Construction Site Auth. Personnel Only
NMD404RB	Danger Construction Keep Out
NMD46RB	Danger Hard Hat Area
NMD79RB	Danger No Smoking
NMD9RB	Danger Auth. Personnel Only
NMN119RB	Notice Visitors Must Register at Office
NMSF47RB	First Aid Kit Inside



EMPIRE LEVEL
Flagging Tape

- Fluorescent colors
- Durable plastic remains pliant in cold weather
- 200' x 1" rolls



Item #	Color
EE77-001	Lime Green
EE77-002	Orange
EE77-003	Pink

EMPIRE LEVEL
Caution/Danger Barricade Tape

- Made of durable plastic
- Plastic remains pliant in cold weather



Item #	Desc.	Size (in. x ft.)
EE77-0204	Red -Danger/ Peligro	3 x 200
EE77-1001	Yellow- Caution	3 x 1000
EE77-1002	Yellow - Caution/ Cuidado	3 x 1000
EE77-1004	Red - Danger	3 x 1000



EAGLE MANUFACTURING CO.
Safety Cans

Metal Type I

- Meets OSHA requirements and are UL and FM approved
- Made of galvanized steel
- Equipped with brass pour spout and flame arrestor



Item #	Cap.	Color
EAUI-10-S	1 gal.	Red
EAUI-20-S	2 gal.	Red

Diesel

EAUI-20-SY	2 gal.	Yellow
EAUI-50-SY	5 gal.	Yellow

EAGLE MANUFACTURING CO.

Safety Cans

Metal Type II

- Meets OSHA requirements and are UL and FM approved
- Made of galvanized steel
- Equipped with brass pour spout and flame arrestor



Item #	Cap.	Color
EAU2-26-S	2 gal.	Red
EAU2-51-S	5 gal.	Red

Diesel

EAU2-51-SY	5 gal.	Yellow
------------	--------	--------

Accessories

EAFD-25	12" Flex Spout 7/8" O.D.
EAF-15	10" Poly Funnel



BUFFALO INDUSTRIES, INC.

Quick Response Spill Kit

Oil Only

Contains:

- 15 Oil only bonded pads, 3 oil only 3"x4' socks, 1 pair Nitrile gloves, 1 disposable bag and instruction sheet
- Absorbs up to 5 gallons



Item #

BF92001

BUFFALO INDUSTRIES, INC.

Econo Safety Pail Spill Kit™

Universal

Contains:

- Portable 5-gallon pail, 10 pads, 4 socks, 1 qt. Ensorb, 1 disposable bag and zip tie, 1 pair nitrile gloves and goggles, emergency response guide and instruction sheet



Item #

BF92001



BUFFALO INDUSTRIES, INC.
Heavy Weight Sorbent Pads

Oil Only-Meltblown

- Oil-Only sorbents absorb oil-based fluids such as motor oil & hydraulic/transmission fluid
- Meltblown sorbents are the most economical product available
- 100 per poly bag



Item #	Size
BF90850	15"x18" Pad



KIDDE FYRNETICS
Fire Extinguishers
ProLine™



- All corrosion resistant, epoxy coated seamless cylinders
- Easy to operate
- Pictographic operating instructions
- Easy to read pressure gauge
- Stainless steel hose and bracket bands
- Rated for A,B,C class fires
- Dry chemical uses a monoammonium phosphate agent

Item #	Cap. (lbs.)	U/L Rating	H (in.)	W (in.)	Dis-charge Time (sec.)	Range (ft.)
--------	-------------	------------	---------	---------	------------------------	-------------

w/ Metal Vehicle Bracket

KI466227-01	2½	1A-10B:C	15	5.3	8-10	6
-------------	----	----------	----	-----	------	---

w/ Wall Hook

KI466112K	5	3A-40B:C	16	7.8	13-15	18
KI466204K	10	4A-60B:C	21.2	8.22	19-21	20
KI466206K	20	10A-80B:C	21.6	8.3	20-22	20
KI466227K	2½	1A-10B:C	15	5.3	8-10	6

Fire Extinguisher Brackets

KI292474	20 (model)
KI366242	10 (model)
KI466400	5 (model)
KI466401	2½ (model)



RHINO
Anti-Fatigue Mats

Cushion Classic™

- Made of resilient rubber that helps minimize the fatigue of long-standing
- Surface texture helps prevent slipping while minimizing dirt trapping; Multi-Nib back adds to comfort while enhancing drainage and cleanliness
- Built-in connector strip on two sides of mat makes it easy to add on mats for coverage of areas with regular proportions
- Grease-resistant rubber stands up to machine tool cutting fluids and similar liquids found in industrial and commercial environments
- Mats - black, Bevels - available black or yellow
- 5/8" Thickness

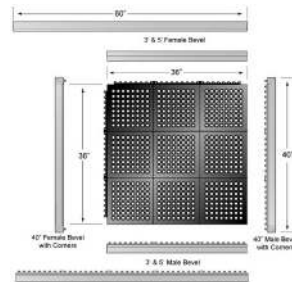

Item #	Desc.
RH57160	36" X 36" Mat
RH56642	36" X 60" Mat
RH57162	36" Bevel Strip Male
RH57164	36" Bevel Strip Female
RH56673	40" Bevel Strip Male w/Corner
RH56674	40" Bevel Strip Female w/Corner
RH56671	60" Bevel Strip Male
RH56672	60" Bevel Strip Female

RHINO
Anti-Fatigue Mats

Diamond Plate™

- Heavy-duty 9/16" thick closed cell polymeric sponge base
- suffers no deterioration from weathering and ozone exposure
- Excellent durability following exposure to many organic and inorganic industrial chemicals
- Available in solid black or gray and black/yellow, gray/yellow



Item #	Size (ft.)
RHDTT2436	2 X 3
RHDTT3660	3 X 5



RHINO
Anti-Fatigue Mats



Ultra-Dome® Modular

- Blend of hollow dome surface with Multi-Nib back provides a resilient, active surface
- Non-directional domed top surface provides excellent traction and a safer work place with high visibility yellow, bevelled borders
- Individual components lock together to create mats of virtually any size; will not pull apart when in use but can easily be unlocked as needed
- Grease-resistant rubber stands up to machine tool cutting fluids and similar liquids



Item #	Desc.	Size (in.)
RHUD33S	Solid Mat	36 X 36
RHUD33D	Drain-thru Mat	36 X 36
RHUD3B	Bevel Strip	36
RHUD18C	Corner Piece	18 X 18



CUSTOM LEATHERCRAFT
Easy-Swivel Kneepads

- Heavy-duty construction throughout
- Heavy plastic front caps for easy knee swiveling
- Thick foam interior for all-day comfort
- One size fits all
- Buckle style fastening system with adjustable straps for convenience, comfort, fit and durability



Item #
CSV6355

CUSTOM LEATHERCRAFT
Leather Kneepads

Heavy-Duty

- Double 1/2" thick water-repellent felt lining for all-day comfort
- One size fits all
- Adjustable leather straps with steel buckles
- Riveted for extra strength



Item #
CS313

CUSTOM LEATHERCRAFT
Non-Skid Professional Kneepads

Ultraflex™

- Sure grip shell surface
- Thick foam inner pads for all-day comfort and protection
- Designed for tile-setters, plumbers, roofers
- Adjustable rubber straps to fit all sizes



Item #
CS361

CUSTOM LEATHERCRAFT
Non-Skid Kneepads

- Exclusive grooved cap design prevents thread abrasion
- Buckle style fastening system with adjustable straps
- Comfortable foam padding for extra knee protection
- Super tough, lightweight fabric covering
- One size fits all



Item #
CSV236

CUSTOM LEATHERCRAFT
Non-Skid Kneepads

- Soft, flexible outer shell protects and grips most surfaces without scratching or scuffing
- High density, closed-cell foam inner pad for all-day comfort
- One size fits all



Item #
CS369

CUSTOM LEATHERCRAFT
Professional Gel Kneepads

- Special CLC "Comfort Zone" gel center provides maximum cushioning for all day wearability
- Crafted from 1680D Ballistic nylon and 3/4" foam for increased comfort
- Two strap fastening for added stability
- Breathable Neoprene lower straps secure below the knee for comfort all day long
- Low profile cap designed to prevent "roll-over" onto hard surface
- Elastic upper straps with "buckle-style" fasteners for rapid fit



Item #
CSG340



CUSTOM LEATHERCRAFT

Professional Gel Kneepads

Ultra-Flex®

- Special CLC "Comfort Zone" gel center provides maximum cushioning for all day wearability
- Super Accordion, Ultra-Flex construction for comfort and protection
- Durable rubber straps for added stability; maximum memory foam layer under gel center for greater comfort
- Soft, flexible outer shell protects and grips most surfaces without scratching or scuffing
- One size fits all



Item #

CSG361

CUSTOM LEATHERCRAFT

Mason's Tool Bags

- Heavy-duty canvas; top grain leather handles and straps
- Heavy gauge hinged steel frame for tight closure
- 7-1/2" x 9" canvas pocket inside; 24" x 14" deep



Item #

CS308

CUSTOM LEATHERCRAFT

Standard BigMouth Bag

33 Pocket

- 11 multi-use pockets inside and 22 outside organize tools and parts
- Internal metal frame holds bag wide open for easy access
- Reinforced interior bottom panel; padded sides and bottom prevent scuffing floors or countertops
- 14"L x 7"W x 10"H



Item #

CS1135

CUSTOM LEATHERCRAFT

Large BigMouth Bag

39 Pocket

- 13 multi-use pockets inside and 26 outside organize tools and parts; internal metal frame holds bag wide open for easy access
- Reinforced interior bottom panel; padded sides and bottom prevent scuffing floors or countertops
- 18"L x 8"W x 12"H



Item #

CS1136

CUSTOM LEATHERCRAFT Large Traytote™ Bags

14 Pocket

- 2 pockets inside, 12 outside
- Heavy-duty stitching, reinforced web handles
- 13-1/2" x 6" multi-compartment plastic tray included, slides securely into bottom of bag
- Opens wide for easy access
- 16"L x 9"W x 12"H



Item #

CS1139

CUSTOM LEATHERCRAFT

Traytote™ Bag

12 Pocket

- 2 pockets inside, 10 pockets outside
- 11"x6" multi-compartment plastic tray slides securely into bottom of bag
- Reinforced web carrying handles
- Opens wide for easy access to bag contents
- 12"L x 8"W x 12"H



Item #

CS1137

CUSTOM LEATHERCRAFT

Tool Organizer Bag

28 Pocket

- 7" x 5-1/2" multi-compartment plastic tray included, slides securely into bottom of pouch
- Box-shaped design prevents tipping
- Pockets for drill bits and tips, electrical tape strap, etc.
- Extra padded carrying handles and adjustable shoulder strap
- Metal tool snap and electrical tape strap
- 8"L x 8"W x 17"H



Item #

CS1526

CUSTOM LEATHERCRAFT

Double Traytote™ Bag

36 Pocket

- 36 multi-use outside pockets
- Pockets for cordless drill, cell phone, 2-way radio, etc.
- Two 11" x 6" multi-compartment plastic trays included, slides securely into bottom of bag
- Reinforced carrying handles and adjustable shoulder strap
- 24"L x 9"W x 12"H



Item #

CS1141



CUSTOM LEATHERCRAFT
Megamouth™ Tote Bag

32 Pocket

- 8 multi-use pockets inside and 24 outside organize tools and accessories
- Internal metal frame holds bag open for easy access
- Large interior to carry power tools, circular saws, hardhats, etc.
- Padded handles and adjustable shoulder strap
- 24"L x 11"W x 12"H



Item #

CS1164

CUSTOM LEATHERCRAFT
BigMouth™ Bag

22 Pocket
Mossy Oak®

- 12 Multi-use pockets inside and 10 outside organize tools and accessories
- Opens wide for easy access to bag's content
- Adjustable shoulder strap
- Padded reinforced web carrying handles
- Heavy-duty stitching and bar tacking at all stress points
- 16" x 8-1/2" x 10"



Item #

CS1165M

CUSTOM LEATHERCRAFT
Center Tray Tool Bag

15 Pocket

- 13-1/2" x 9" Multi-compartment plastic tray included, stored into middle compartment for easy access to the rest of bag contents
- 8 pockets outside and 7 inside to organize a wide range of tools and accessories
- Main pocket with web loops to accommodate large handle tools
- Extra padded carrying handles and adjustable shoulder strap
- Metal tool snap and electrical tape strap
- 16"L x 9"W x 9"H



Item #

CS1529

CUSTOM LEATHERCRAFT
Softsided Carpenter's Tool Box

24 Pocket

- 16 Multi-use outside pockets and 8 inside pockets to organize tools and accessories
- Large interior to carry a wide variety of carpenter's tools; padded rubber web carrying handle and adjustable shoulder strap
- 2 large side pockets with loops to hold large handle tools; mesh zippered pocket for easy view of pocket contents
- 18"L x 9"W x 12"H



Item #

CS1532

CUSTOM LEATHERCRAFT
Multi-Compartment Tool Carrier

58 Pocket

- 54 Pockets inside and 4 pockets outside to organize tools and accessories
- Large center compartment to carry multiple power tools and accessories and separate outside two compartments; zippered side panels prevent spillage of tools when carrying or storing carrier
- Vertical tool pockets keep them in sight for quick access
- 18"L x 7"W x 14"H



Item #

CS1539

CUSTOM LEATHERCRAFT
Softsided Tool Box

33 Pocket

- 21 Multi-use outside pockets and 12 inside pockets to organize a wide range of tools and accessories
- Padded rubber web carrying handle and adjustable shoulder strap
- 8" x 4" Multi-compartment plastic tray to organize small parts or accessories; large interior to carry a wide variety of tools and accessories
- 18" L x 9-1/2" W x 14" H



Item #

CS1572

CUSTOM LEATHERCRAFT
Tote Bag

23 Pocket

- 10 Pockets inside and 13 pockets outside to organize tools and accessories
- 10" x 3" Multi-compartment plastic tray to organize small parts, recessed on top for easy access; reinforced web carrying handles and adjustable shoulder strap
- 16"L x 8"W x 11"H



Item #

CS1534



CUSTOM LEATHERCRAFT
Electrician's Tool Pouch

21 Pocket

- Double layer of rugged, lightweight 600D polyester fabric
- Zippered top flap to prevent spillage of tools when not in use
- Ergonomic rubber handle and padded shoulder strap design for easy storage and the ideal way to carry loaded tool pouch
- Zippered back pocket for 8" x 5" writing pad
- Outside pocket to hold cell phone holder and 3 outside large screwdriver holders



Item #
CS1509

CUSTOM LEATHERCRAFT
Electrical & Maintenance Tool Carrier

23 Pocket

- 11" x 6" Multi-compartment plastic tray included that slides securely into bottom of tool carrier organizes small parts
- 16 Multi-use outside pockets and 7 inside to organize a wide range of tools and accessories
- Box shaped design prevents tipping
- Extra padded carrying handle and adjustable shoulder strap
- Large main divided pockets with elastic loops to accommodate large tools
- Electrical tape strap
- 11"L x 10"W x 19"H



Item #
CS1528

CUSTOM LEATHERCRAFT
Electrical & Maintenance Tool Pouch

17 Pocket

- Heavy-duty top grain leather
- Box-shaped design prevents tipping
- Large divided main pocket for extra tool capacity
- Leather reinforced carrying handle and electrical tape chain
- 8" L x 8" W x 15" H



Item #
CS526

CUSTOM LEATHERCRAFT
Pro Electrician's Tool Pouch

20 Pocket

- New handle and padded shoulder strap design for easy storage and the ideal way to carry loaded tool pouch
- Double layer of rugged lightweight Dupont Cordura Plus fabric
- Heavy-duty tool snap and electrical tape strap; steel hammer loop
- Adjustable shoulder strap
- 6 Large screwdriver holders



Item #	Part #
CS5508	5508

CUSTOM LEATHERCRAFT
Carpenter's Nail & Tool Bag

8 Pocket

- Reversed top grain leather
- 2 Large capacity main nail/tool pockets
- 6 Smaller pockets fit pencils, nail sets, pliers, etc.
- Fits belts up to 2-3/4" wide
- 2 Steel hammer loops



Item #
CS178234

CUSTOM LEATHERCRAFT
Electrician's Tool Pouch

9 Pocket

- Chrome-tanned top grain leather
- 1 Main deep pocket
- 7 Additional front and side pockets for screwdrivers, wrenches, etc.
- Fits belts up to 2-3/4" wide
- Leather hammer loop
- Leather holder fits up to 30' measuring tape
- Tape chain and metal tool clip



Item #
CSK500

CUSTOM LEATHERCRAFT
Nail & Tool Bag

8 Pocket

- Suede leather
- 2 main reversed nail/tool pockets
- 6 smaller pockets fit pliers, nail sets, pencils, etc.
- Fits belts up to 2-3/4" wide
- 2 Leather hammer loops



Item #
CSI823X



CUSTOM LEATHERCRAFT
**3-Piece Electrical
Combos**



20 Pocket

- Totally versatile-all parts removable and interchangeable
- Double layer of rugged, lightweight nylon
- Grip-Strip™ hook and loop fastener system keeps pouches in place
- Sta-Open™ feature on main pockets
- Metal clip holds all measuring tape sizes
- Metal tape chain and tool snap
- Pocket to hold cordless drill
- 3" wide padded comfort belt with double tongue roller buckle
- Fits waist sizes 29" - 46"

Item #

CS5609

CUSTOM LEATHERCRAFT
**Pro-Framer's
Combo System**



19 Pocket/4-Piece

- Heavy-duty top grain leather
- Easy Carry Handle design provides simple adjustments, easy carrying and storage of combo without spilling contents
- 8 main reversed nail/tool pockets
- 9 smaller pockets fit pliers, nail sets, pencils, knife, etc.
- 2-3/4" wide padded heavy leather belt with double tongue steel roller buckle
- Fits waist sizes 29" - 46"

Item #

CS21452

CUSTOM LEATHERCRAFT
**Pro-Framer's
Combo System**



27 Pocket/4-Piece

- Crafted from super tough, double layered 1680 ballistic nylon and top grain leather
- Easy Carry Handle design provides simple adjustments, easy carrying and storage of combo without spilling contents
- 8 main reversed nail/tool pockets
- 17 smaller pockets fit pliers, nail sets, pencils, knife, etc.
- 5" wide padded comfort belt with double tongue steel roller buckle
- Fits waist sizes 29" - 46"

Item #

CS51452

CUSTOM LEATHERCRAFT
Electrical Combo System



**29 Pocket/3-Piece
ComfortLift™**

- Crafted from super tough, double layered 1680 ballistic nylon and top grain leather
- Completely adjustable, padded suspenders engineered to hold and distribute weight evenly without strain on lower back and hips
- Easy Carry Handle design provides for simple adjustments and easy storage without spilling contents; zippered top flap pouch to prevent spillage of tools when not in use
- Extra padded back for extra comfort; large screwdriver side holders; metal hammer holder, tool snap and web strap
- Includes a 3" wide padded comfort belt, with 2" double tongue metal roller buckle
- Fits waist sizes 29" - 46"

Item #

CS51609

CUSTOM LEATHERCRAFT
Framer's Combo System



**26 Pocket/3-Piece
ComfortLift™**

- Crafted from super tough, double layered 1680 ballistic nylon and top grain leather
- Completely adjustable, padded suspenders engineered to hold and distribute weight evenly without strain on lower back and hips
- Easy Carry Handle design provides for simple adjustments and easy storage without spilling contents
- 5 main nail/tool pockets; 19 smaller pockets fit pliers, nail sets, pencils, knife, etc.
- Leather combination square and pry bar holders
- Newly designed Sta-Open main pockets are tapered for faster access to contents
- Includes a 3" wide padded comfort belt, with 2" double tongue metal roller buckle
- Fits waist sizes 29" - 46"

Item #

CS51714

CUSTOM LEATHERCRAFT
**Professional
Carpenter's Combo**



18 Pocket/5-Piece

- Easy Carry Handle design provides simple adjustments, easy carrying and storage of apron without spilling contents
- Totally versatile-all parts removable and interchangeable; Sta-Open feature on main reversed pockets
- 9 Main pockets for tools/nails, etc.; 6 Smaller pockets for screwdrivers, cutters, pliers, pencils, etc.
- Speed square and pry bar holders; 2 Steel hammer loops
- Metal clip holds all measuring tape sizes
- 5" Wide padded comfort belt with double tongue steel roller buckle
- Fits waist sizes 29" - 46"

Item #

CS5605



CUSTOM LEATHERCRAFT
**Framer's Comfort
Lift System**

31 Pocket/5-Piece



- Unique, padded suspenders engineered to carry loads comfortably and distribute weight evenly without strain on lower back and hips
- Easy Carry Handle design provides for simple adjustments and easy storage without spilling contents
- Pockets with more capacity and easy access to contents
- Cell phone holder on upper part of suspenders for easy access
- Bottoms of main pockets are reinforced with PVC material for better resistance to abrasion
- Metal hook to carry cordless drill, nail guns or other power tools
- 5" Wide padded comfort belt with double tongue steel roller buckle
- Fits waist sizes 29"- 46"

Item #

CS6714

CUSTOM LEATHERCRAFT
Bucket Pocket

30 Pocket



- 14 multi-size pockets inside and 16 outside organize a wide range of tools & accessories
- Designed to fit most standard 3-1/2 to 5 gallon buckets
- Heavy-duty stitching

Item #

CS1117

CUSTOM LEATHERCRAFT
Bucket Pocket

30 Pocket/Outside



- 30 multi-size outside pockets organize a wide range of tools & accessories
- Drill pocket with hook & loop handle strap
- Tape strap & key clip
- Security pocket with hook and loop closure
- Designed to fit most standard 3-1/2 to 5 gallon buckets

Item #

CS1118

CUSTOM LEATHERCRAFT
Drawstring Bucket Bag

22 Pocket



- 6 large compartments for organizing and stowing small parts
- 16 pockets outside/inside for a variety of tools and accessories
- Easy-lock/pushbutton-release draw-string system
- "Soft" bottom panel prevents tipping and spilling
- 10" round x 7" high

Item #

CS1148

CUSTOM LEATHERCRAFT
Bucket Pocket

48 Pocket



- 14 Double row pockets inside and 34 triple row outside organize a wide range of tools and accessories
- Drill pocket with hook and loop handle strap
- Designed to fit most 3-1/2 to 5 gallon buckets
- Measuring tape strap and key clip included

Item #

CS1119

CUSTOM LEATHERCRAFT
Bucket Pocket

61 Pocket-In & Out



- Made of durable, rugged, 600D Ripstop fabric
- 36 Triple row outside pockets, 25 double row inside pockets
- Drill holder with side release buckle security strap
- Designed to fit most standard 3-1/2 to 5 gallon buckets

Item #

CS4122

CUSTOM LEATHERCRAFT
Bucket Seat

EasySeat™



- The original contoured bucket seat
- Turns standard 3-1/2 - 5 gallon bucket into comfortable seat
- Grooved design channels away moisture
- Durable, lightweight plastic

Item #

CS1140



CUSTOM LEATHERCRAFT
Cell Phone Holders

Keystone Series



- Belt clip swivels to accommodate wearing on left or right side

Item #	Desc.
CS1517	BlackBerry®-style/iPhone®
CS1520	Smaller phones, Magnet® close
CS1521	Larger phone/walkie-talkie

CUSTOM LEATHERCRAFT
Cell Phone Holder

- Specially designed to hold newer/smaller cell phones; versatile 2-way attachment for belts, pants, etc.
- Heavy-duty clip on back, elastic side panels and padded inside to protect cell phones



Item #	Desc.
CS5124M	Mossy Oak®
CS5124	Black

CUSTOM LEATHERCRAFT
16' - 30' Tape Rule Holder

- Top grain leather; easy out keel
- Holds larger tape rules
- Molded leather front retains its shape
- Fits belts up to 2-3/4" wide



Item #
CS465

CUSTOM LEATHERCRAFT
Hammer Holder

Steel Loop

- Top grain leather
- Cradle design eliminates hammer pivoting
- Fits belts up to 2-3/4" wide



Item #
CS439

CUSTOM LEATHERCRAFT
Plier/Tool Holder

- Top grain leather
- Molded, closed-bottom design retains shape
- Fits belts up to 2-1/4" wide



Item #
CS418

CUSTOM LEATHERCRAFT
Plier Holder

- Top grain leather
- Fits narrow-type hand tools up to 10" long
- Molded leather retains shape
- Fits belts up to 2-1/4" wide

Item #
CS767



CUSTOM LEATHERCRAFT
Leather Work Belt

- Trim to fit waist sizes 29"-46"
- Steel single tongue roller buckle
- 2" embossed top grain leather



Item #
CSE4521

CUSTOM LEATHERCRAFT
Back Support Belts

- 8" wide heavy-duty elastic back panel
- 5" wide heavy elastic side bands for custom fit
- 1-1/4" wide elastic adjustable suspenders
- 4 internal stays provide extra support
- Tapered front panels for comfort while bending



Item #	Fits Waist Sizes (in.)
CS5000M	32 - 38
CS5000L	38 - 47
CS5000XL	46 - 56

CUSTOM LEATHERCRAFT
Work Suspenders

- 2" wide heavy-duty elastic straps
- Adjustable to fit all sizes
- Heavy-duty front and rear clips
- Red white & blue graphic print



Item #
CS110USA

CUSTOM LEATHERCRAFT
Padded Work Suspenders

- 2" Wide foam-filled comfort pads
- Heavy-duty clips front and back
- Comfortable heavy-duty straps
- Adjustable to fit all sizes



Item #
CS5121



CUSTOM LEATHERCRAFT
Leather Suspenders

- Fully adjustable
- Shoulder pads for added comfort
- Reduces load of heavy nail bags and aprons
- Heavy-duty top grain leather



Item #
CS21110

CUSTOM LEATHERCRAFT
Web Tie Down Straps

- Strong 1" heavy-duty web construction
- Rustproof, cam-action buckle



Item #	Length (ft.)	Color
CSWS02	2	Red
CSW04	4	Yellow
CSW06	6	Green
CSW08	8	Purple
CSW10	10	Blue
CSW12	12	Black

Edge installs permanent fall restraint systems.

Call for more information.

Don't see what you need?

Call an Edge sales representative to inquire about other safety products.

Jenny

JENNY

Hand Carry Portable Air Compressor

Electric, 4 Gallon

- Lightweight, compact & extremely portable
- Cast iron cylinder for extended pump life
- Single stage, direct coupled, oil lubricated pump
- Powder coated heavy-duty steel tank and frame assembly
- Protectively mounted fittings; forced ventilation cooling system
- Air line regulator and two gauges for line and tank pressure
- Anti-vibration feet; pressure relief safety valve
- Special unloading valves to assist in motor/engine starting



Item #

JNA2G246-HC4V

JENNY

Single Stage Wheeled Portable Air Compressors

Electric

- Heavy-duty single stage cast iron compressor pump made in Somerset, PA USA
- Splash lubricated; totally enclosed heavy-duty belt guard
- Belt driven w/a large flywheel for extra cooling and easier start-up
- 8 & 15 gallon tanks are low profile, powder coated twin tank receivers
- 17 and 30 gallon tanks are powder coated and ASME certified
- Convenient lifting handles
- Anti-vibration feet; protectively mounted fittings
- Special unloading valves to assist in motor starting; Tank gauge; regulator and outlet pressure gauge



Item #	Pump	HP	Tank Gallon	Power Supply	CFM @ 100 PSI	CFM @ 125 PSI
JNK15A-8P	K	1.5	8	115 or 230 Volt 1 Phase	6.5	6.2
JNK15A-15P	K	1.5	15	115 or 230 Volt 1 Phase	6.5	6.2
JNK15A-17P	K	1.5	17	115 or 230 Volt 1 Phase	6.5	6.2
JNK15A-30P	K	1.5	30	115 or 230 Volt 1 Phase	6.5	6.2
JNK2A-8P	K	2	8	115 or 230 Volt 1 Phase	8.4	8.0

JENNY

Single Stage Wheeled Portable Air Compressors

Gas Powered

- Heavy-duty single stage cast iron compressor pump made in Somerset, PA USA
- Totally enclosed heavy-duty belt guard; belt driven with a large flywheel for extra cooling and easier start-up
- 8 & 15 gallon tanks are low profile, powder coated twin tank receivers; 17 and 30 gallon tanks are powder coated and ASME certified
- Convenient lifting handles; anti-vibration feet; protectively mounted fittings
- Splash lubricated; special unloading valves to assist in engine starting
- Tank gauge; regulator and outlet pressure gauge



Item #	Pump	HP	Tank Gallon	Drive	CFM @ 100 PSI	CFM @ 125 PSI
JNK5HGA-8P	K	5.5	8	Honda GX Gasoline Engine Recoil Start	8.9	8.6
JNK5HGA-17P	K	5.5	17	Honda GX Gasoline Engine Recoil Start	8.9	8.6
JNK5HGA-30P	K	5.5	30	Honda GX Gasoline Engine Recoil Start	8.9	8.6
JNG8HGA-17P	G	8	17	Honda GX Gasoline Engine Recoil Start	16.2	15.6



CHICAGO PNEUMATIC TOOL CO.

Portable Compressor

- Offers many features asked for by the rental industry
- The corrosion resistant galvanized steel canopy will ensure many years of service
- A compact, lightweight design with recessed towing lights and a rear bumper provide greater maneuverability and added safety while towing
- Features a highly efficient, direct-drive airend that provides 185 cfm of compressed air while using only a 49 HP engine
- The control panel and discharge valves are conveniently located at the rear of the compressor

Includes:

- Toolbox; recessed towing lights; rear bumper
- Electric fuel gauge; low fuel shutdown
- Direct drive airend; single point lifting eye
- 49 HP Perkins engine (Interim Tier 4); glow plug engine preheat
- Wide opening one piece canopy; galvanized steel canopy; torsion bar suspension
- Protective shutdown system for high compressor temperature, low oil pressure, low fuel level
- Folding drawbar with adjustable jackstand and safety chains

Centralized Controls:

- Control panel and discharge valves are conveniently located on the rear of the compressor
- The control panel includes an hourmeter, discharge pressure gauge, electric fuel gauge, engine preheat actuator and rotary start switch
- The control system also provides protective shutdowns for high engine temperature, low oil pressure, high compressor temperature and low fuel level



Item #	Free Air Delivery (cfm)	Working Pressure (PSI)	Max Unloading Pressure (PSI)	Discharge Valves	Fuel Tank Capacity (gal.)	Number of Cylinders	Cooling System	Overall Length (in.)	H x W (in.)	Weight (lbs.)
CPCP 185 PD	185	100	125	(2) x 3/4"	25	4	Water	125	57 x 60	2,375

CHICAGO PNEUMATIC TOOL CO.

Portable Compressor

- Provides the strength and flexibility required for today's demanding applications
- The sturdy A-frame drawbar, mechanically controlled Perkins engine and 500 hour maintenance intervals assure many years of dependable service
- Standard features include road lights, electric fuel gauge, low fuel shutdown and full length lockable doors
- A built-in aftercooler, water separator, primary and secondary filter package is available as an option for applications where clean, dry compressed air is critical

Includes:

- 500 hour service interval
- Large tool storage box; unloaded starting
- Torsion bar suspension
- 111 HP Perkins engine (Tier 3); Glow plug engine preheat
- Recessed towing lights; dual stage water separator
- Fuel level gauge and hour meter; low fuel shutdown
- Single point lifting eye
- Galvanized sheet metal enclosure with powder coat paint
- Full length lockable doors
- A-frame drawbar with adjustable pintle eye, retractable swivel wheel and safety chains



Item #	Free Air Delivery (cfm)	Working Pressure (PSI)	Max Unloading Pressure (PSI)	Discharge Valves	Fuel Tank Capacity (gal.)	Number of Cylinders	Cooling System	Overall Length (in.)	H x W (in.)	Weight (lbs.)
CPCPS 375	375	100	125	(2) x 3/4" & (1) x 1 1/2"	38	4	Water	145	71 x 72	3,860



AIRMAN
Air Compressor

Sunami Series



- Electric fuel prime and air-bleed
- Low noise level
- Stainless steel exhaust
- CFM: 185

Item #	Working Pressure (PSI)	Rated Output (HP @ RPM)	Fuel Capacity (Gal)
R-AIPDS185S	100	50.8 @ 3000	21



MAKITA USA
Electric Air Compressor

**Hot Dog
MAC700**



- Low Noise
- Low Amp Draw
- Oil Lubricated - Cooler running pump, minimizes wear
- Large automotive style industrial air filter
- Durable cast iron cylinder
- Oil sight glass for fast, easy and efficient maintenance
- Lever handle ball valve - tank drain valve improves upon standard petcock design for easier maintenance
- Built-in thermal overload for additional motor protection

Includes:

- 1/4" Brass Makita Universal Coupler
- Horsepower: 2.0hp; tank (ga.): 2.6 "Hot Dog"hp
- Pump: Oil-lubricatedhp
- Performance (CFM): 90 PSI 3.3; 40 PSI 3.8hp
- Operating Pressure (PSI): 0 - 130hp
- AMPS: 12.4hp
- Noise Level (dB): 80hp
- Size: 18"x10"x22"

Item #
MAMAC700



MAKITA USA
Air Compressor

3.0 HP
"Wheelbarrow"



- Folding Handle - For easy storage
- Built-in Storage Compartment - Stores air fittings & accessories
- Oil Lubricated
- Air Hose Wrap - Stores 50' of 3/8" Air Hose with handle folded or upright
- Large automotive style industrial air filter
- Durable cast iron cylinder
- Roll cage construction
- Oil sight glass for fast, easy and efficient maintenance
- Finned discharge tubing for increased heat dissipation and reduced moisture in the air
- Lever handle ball valve - tank drain valve improves upon standard petcock design for easier maintenance
- Convenient oil drain at the front of the pump for easy access
- Built-in thermal overload for additional motor protection

Includes:

- 1/4" Brass Makita Universal Coupler
- Horsepower: 3.0; tank (ga.): 5.2
- Pump: Oil-Lubricated
- Performance (CFM): 90 PSI 6.5, 40 PSI 6.9
- Operating Pressure (PSI): 0 - 140
- AMPS: 13.8 ; noise Level (dB): 90
- Size: 29"x19"x19-1/2"

Item #
MAMAC5200



YAMAHA MOTOR CORP.
Portable Generator

Premium Gasoline Powered



- Maintenance free, brushless, single phase
- Auto-Decompression for easy starting
- Oil Watch Warning System shuts things down before the oil level gets low and won't let the generator be restarted until oil is added
- Auto Voltage Regulation to ensure correct power delivery even with extension cords
- Transistor Controlled Ignition
- Noise Suppressor

Item #	Rated Voltage	Frequency	Max/Rated AC Output	Battery Start
YMYG-4000DX	120/240V	60 Hz	4000/3500 watts	N
YMYG-5200DX	120/240V	60 Hz	5200/4500 watts	N
YMYG-6600DX	120/240V	60 Hz	6600/6000 watts	N
YMYG-6600DEX	120/240V	60 Hz	6600/6000 watts	Y



YAMAHA MOTOR CORP.

Portable Generator

Gasoline Powered

- Compact and only 92.6 pounds
- 2.9-gallon fuel tank (with gauge) that provides 11 hours of run time on a single tank of gas
- Ground fault interrupter and non-fuse thermal breaker circuitry
- Oil Watch Warning System protects the heavy duty 171cc engine
- Mechanical governor delivers consistent engine speed for smoother power, while rubber mounts and a quiet muffler keep the noise to a minimum



Item #	Type	Rated Voltage	Frequency	Max/Rated AC Output	Battery Start
YMEF-2600	Brushless	120V	60 Hz	2600/2300 watts	N

YAMAHA MOTOR CORP.

Portable Generator

Gasoline Powered Inverter Series

- Inverter technology: clean power, quiet & fuel efficient
- Maintenance free, brushless, single phase
- Smart Throttle automatically adjusts the engine speed to precisely match the load
- Exceptional fuel economy and is remarkably quiet
- Pulse Width Modulation produces high quality, clean electricity that's ideal for powering tools and equipment with built-in microprocessors or microcomputer-controlled electric tools
- Oil Watch Warning System



Item #	Rated Voltage	Frequency	Max/Rated AC Output	DC Output	Battery Start
YMYG-2800i	120V	60 Hz	2800/2500 watts	8.3 amps	N

YAMAHA MOTOR CORP.

Portable Generator

Gasoline Powered Inverter Series

- Inverter technology: clean power, quiet & fuel efficient
- Noise Block technology housing (53-60 dBA)
- Boost Technology sense when extra power need and boosts output for up 10 seconds
- Built-in ergonomic handles and sturdy wheels make moving the generator smooth and easy
- Pulse Width Modulation, Smart Throttle, Oil Watch Warning System



Item #	Type	Rated Voltage	Freq.	Max/Rated AC Output	DC Output	Battery Start
YMEF30iSE	Brushless Inverter	120V	60 Hz	3000/2800 watts	12 volt 12 amps	Y

YAMAHA MOTOR CORP.

Portable Generator

Gasoline Powered Inverter Series

- Meeting the strictest environmental standards, it's simply the greenest way ever to power up
- Lightweight, 44 lbs. - easy to move, transport and store
- Super quiet muffler with USFs approved spark arrestor
- Twin Tech capability - hook up two for maximum power
- Smart Throttle varies engine speed based on load
- Oil Watch Warning System - prevents engine damage
- Fuel gauge
- Electrical overload breaker



Item #	Type	Rated Voltage	Freq.	Max/Rated AC Output	DC Output	Battery Start
YMEF2000iS	Brushless Inverter	120V	60 Hz	2000/1600 watts	12 volt 8 amps	N



YAMAHA MOTOR CORP.
Generator Wheel Kit

- For ease of maneuverability these wheel kits are ideal
- Heavy-duty solid rubber tires to eliminate flats
- Handles are made to fold down to reduce space requirements and potential damage
- Fits EF4000DE, EF4600DE, EF5200DE, EF6600DE, YG4000D, YG5200D, YG6600D and YG6600DE
- Chrome finish



Item #
YMACC-WHEEL-KI-TC



CHICAGO PNEUMATIC TOOL CO.
Reversible Pneumatic Drills

- CFM: 24
- Air Inlet: 1/4" NPT
- Air Hose Bore: 3/8"
- Spindle Thread Size: 3/8"-24



Item #	Chuck Size (in.)	Free Speed (RPM)
CPCP9789	1/2	800
CPCP9790	3/8	2000

CHICAGO PNEUMATIC TOOL CO.
Aluminum Body Air Hammer

- CFM: 25
- Air Inlet: 1/4" NPT
- Air Hose Bore: 3/8"



Item #	BPM
CPCP9311	3000
CPCP9315	2300

CHICAGO PNEUMATIC TOOL CO.
Super Duty Hammer

- Pistol grip hammer; easy change retainer for quick accessory change
- Standard .401 round shank
- BPM: 3500

Item #
CPCP716



CHICAGO PNEUMATIC TOOL CO.
Pistol Grip Hammer

- Standard .401 round shank
- Easy change retainer for quick accessory change
- BPM: 3000

Item #
CPCP7111



CHICAGO PNEUMATIC TOOL CO.
Impact Wrenches

CPRP9540B:

- Working Torque: 25-310 ft./lbs.
- Torque Max: 425(ft./lbs.)
- CFM: 15
- Air Inlet: 1/4" NPTF
- Clutch: Dyna Pact™



CPRP9560:

- Working Torque: 200-950 ft./lbs.
- Torque Max: 1360(ft./lbs.)
- CFM: 24
- Air Inlet: 1/4" NPTF
- Clutch: Pin

CPRP7763:

- Working Torque: 100-950ft./lbs.
- Torque Max: 1200(ft./lbs.)
- CFM: 30
- Air Inlet: 3/8" NPTF
- Clutch: Twin Hammer

Item #	Drive End (in.)
CPRP9540B	1/2
CPRP9560	3/4
CPRP7763	3/4

CHICAGO PNEUMATIC TOOL CO.
Extreme Duty Impact Wrench

- BPM: 1580
- CFM: 5.5
- Working Torque: 50-550 ft./lbs.
- Torque Max: 600(fwd)/800(rev)(ft./lbs.)
- Air Inlet: 1/4" NPTF
- Min. Hose Size: 3/8"



Item #	Drive End (in.)
CP-7750	1/2

CHICAGO PNEUMATIC TOOL CO.
High Power Pneumatic Ratchets

- CFM: 16; Free Speed: 150 RPM
- Torque Range: 10-50 (ft./lbs.); Air Inlet: 1/4" NPT; Air Hose Bore: 3/8"



Item #	Drive End (in.)
CPCP9429	3/8
CPCP9430	1/2



CHICAGO PNEUMATIC TOOL CO.

1/2" Heavy-Duty Ratchet



- Features CP's patented TriSpring anti-slip head design
- Compact, yet packed with power and speed; hardened gears

Item #
CPCP828H

CHICAGO PNEUMATIC TOOL CO.

In Line Die Grinder



- Power: 0.5 H. P.
- Free Speed: 24,000 RPM; CFM: 22
- Air Inlet: 1/4" NPT; Air Hose Bore: 3/8"

Item #
CPCP9113

CHICAGO PNEUMATIC TOOL CO.

Mini Angle Die Grinder



- Power: .2 H.P.; Free Speed: 22,500 RPM
- Air Inlet: 1/4" NPTF

Item #
CPRP875

CHICAGO PNEUMATIC TOOL CO.

Standard Duty Die Grinder



- Free Speed: 22,000 RPM
- CFM: 26
- Air Inlet: 1/4" NPTF

Item #
CPRP872

CHICAGO PNEUMATIC TOOL CO.

Angle Head Die Grinder



- Power: .25 H.P.
- Free Speed: 25,000 RPM; CFM: 19
- Air Inlet: 1/4" NPT; Air Hose Bore: 3/8"

Item #	H.P.	Free Speed (RPM)	CFM	Air Inlet (in.)	Air Hose Bore (in.)
CPRP9106	0.25	25000	19	1/4 NPT	3/8

CHICAGO PNEUMATIC TOOL CO.

Angle Grinder 4-1/2" x 5/8"-11

- Power: 0.8 H.P.
- Free Speed: 12,000 RPM
- Air Inlet: 1/4" NPT; Air Hose Bore: 3/8"

Item #
CPRP9122BR



CHICAGO PNEUMATIC TOOL CO.

7" Angle Grinder

- Power: 1.12 H.P.
- Free Speed: 7,500 RPM
- Air Inlet: 3/8"; Air Hose Bore: 1/2"



Item #
CPCP9123

CHICAGO PNEUMATIC TOOL CO.

Compact Engraving Pen



Item # BPM
CPCP9160 32400

CHICAGO PNEUMATIC TOOL CO.

Engraving Pen Kit



Item #
CP-9361-1

CHICAGO PNEUMATIC TOOL CO.

Needle Scalers



Item #	Bore & Stroke (in.)	BPM	Handle
CPCP0951	25/32x1 1/8	3600	Lever
CPCP0952	15/16x1 1/8	3900	Offset

CHICAGO PNEUMATIC TOOL CO.

Needle Scaler with Chisel

- Bore: 1-1/8"; BPM: 4600
- CFM: 15.5; Air Inlet: 1/4" NPT
- Shank: 1/2"; Min. Hose Size: 3/8"



Item #
CPCP9538

CHICAGO PNEUMATIC TOOL CO.

Heavy-Duty Reciprocating Saw



Item #	Stroke (in.)	BPM	CFM	Air Inlet (in.)	Air Hose Bore (in.)
CPRP9881	1	5000	27	1/4 NPT	3/8

CHICAGO PNEUMATIC TOOL CO.

Industrial Weld Flux Chipper

Industrial Needle Scaler

- Super durable for extreme applications
- Only 3.7 lbs.; 4,600 BPM



Item #
CPCP9356
CPCP9356/NS

CPRP9356
CPRP9356/NS



CHICAGO PNEUMATIC CONSTRUCTION EQUIPMENT
4-Bolt High Performance Breakers

30 Pound Class

- Alloy steel forgings provide excellent durability; four-bolt backhead design withstands rugged use
- Integral oiler provides continuous lubrication; oversized springs, side bolts and anvil minimize repairs
- CP Four-bolt breakers require minimal servicing to maintain peak operating efficiency over extended periods of rugged use
- CP Breakers can be ordered with mufflers, or mufflers can be purchased separately
- Air consumption at 90 psi, 45 cfm
- EX = Extended handle for trench work; S = Silenced models



CPCP 0112 S

Item #	Standard Hex Chuck Size (in.)	Retainer Type	Length (in.)	Weight (lbs.)
CPCP 0112	1 x 4¼	Latch	21	30
CPCP 0112 EX	1 x 4¼	Latch	30¾	33
CPCP 0112 S	1 x 4¼	Latch	21	32

CHICAGO PNEUMATIC CONSTRUCTION EQUIPMENT
4-Bolt High Performance Breakers

35 Pound Class

- Alloy steel forgings provide excellent durability; four-bolt backhead design withstands rugged use
- Integral oiler provides continuous lubrication
- Heavy-duty front headsprings on CPCP 1210 reduce reaction to operator
- CPCP 1210S is equipped with a silencer to reduce sound level
- Vibration reduced handle (SVR) is available on the CPCP 1210 SVR
- CP Four-bolt breakers require minimal servicing to maintain peak operating efficiency over extended periods of rugged use
- Oversized springs, side bolts and anvil minimize repairs
- CP Breakers can be ordered with mufflers, or mufflers can be purchased separately
- Air consumption at 90 psi, 48 cfm
- S = Silenced models; SVR = Silenced Vibration + reduced models



CPCP 1210 S

Item #	Standard Hex Chuck Size (in.)	Retainer Type	Length (in.)	Weight (lbs.)
CPCP 1210	1 X 4¼	Latch	21½	44
CPCP 1210S	1 X 4¼	Latch	21½	48
CPCP 1210 SVR	1 X 4¼	Latch	23½	51

Edge rents & repairs breakers!



CHICAGO PNEUMATIC CONSTRUCTION EQUIPMENT
4-Bolt High Performance Breakers

60 Pound Class

- Alloy steel forgings provide excellent durability
- Four-bolt backhead design withstands rugged use
- Integral oiler provides continuous lubrication
- Heavy-duty front headsprings reduce reaction back to operator
- Reversible piston reduces maintenance cost
- Air inlet swivel for easy maneuverability
- CPCP 1230 S is equipped with silencers
- Vibration reduced handle (SVR) available on the CPCP 1230 SVR
- CP Four-bolt breakers require minimal servicing to maintain peak operating efficiency over extended periods of rugged use
- Oversized springs, side bolts and anvil minimize repairs
- CP Breakers can be ordered with mufflers, or mufflers can be purchased separately
- Air consumption at 90 psi, 63 cfm
- S = Silenced models; SVR = Silenced Vibration + reduced models



CPCP 1230 S

Item #	Standard Hex Chuck Size (in.)	Retainer Type	Length (in.)	Weight (lbs.)
CPCP 1230	1½ X 6	Latch	26½	65
CPCP 1230 S	1½ x 6	Latch	26½	68
CPCP 1230 SVR	1½ x 6	Latch	27½	76
CPCP 1230	1¼ x 6	Latch	26½	65
CPCP 1230 S	1¼ x 6	Latch	26½	68
CPCP 1230 SVR	1¼ x 6	Latch	27½	76

CHICAGO PNEUMATIC CONSTRUCTION EQUIPMENT
4-Bolt High Performance Breakers

90 Pound Class

- Alloy steel forgings provide excellent durability
- Four-bolt backhead design withstands rugged use
- Integral oiler provides continuous lubrication
- Heavy-duty front headsprings reduce reaction back to operator
- Reversible piston reduces maintenance cost
- Air inlet swivel for easy maneuverability
- CPCP 1240 S is equipped with silencers
- Vibration reduced handle (SVR) available on the CPCP 1240 SVR
- CP Four-bolt breakers require minimal servicing to maintain peak operating efficiency over extended periods of rugged use
- Oversized springs, side bolts and anvil minimize repairs
- CP Breakers can be ordered with mufflers, or mufflers can be purchased separately
- Air consumption at 90 psi, 81 cfm
- S = Silenced models; SVR = Silenced Vibration + reduced models



CPCP 1240 SVR

Item #	Standard Hex Chuck Size (in.)	Retainer Type	Length (in.)	Weight (lbs.)
CPCP 1240	1½ x 6	Latch	28¾	83
CPCP 1240 S	1½ x 6	Latch	28¾	86
CPCP 1240 SVR	1½ x 6	Latch	30	95
CPCP 1240	1¼ x 6	Latch	28¾	83
CPCP 1240 S	1¼ x 6	Latch	28¾	86
CPCP 1240 SVR	1¼ x 6	Latch	30	95



CHICAGO PNEUMATIC CONSTRUCTION EQUIPMENT

Rivet Busters

With CPS

- Originally designed for cutting and forming metal rivets, the CP buster is now used for concrete demolition and has become one of the stars of the CP range
- It has low frequency blow with hitting power equivalent to a paving breaker twice its weight
- The new CPS includes a stepped piston and step cylinder to prevent accidental ejection of the piston
- Teasing throttle for progressive hitting frequency gives better control of such a powerful machine
- Special Boyer valve makes the cylinder stroke effectively longer for more hitting power
- Boyer valve's high quality design makes the blow more consistent
- Forged steel handle for long life in rugged conditions
- Stepped piston of hardened steel
- New buffer ring is now 90 durometer rubber for extra life
- Stepped piston to prevent accidental ejection of the piston



CPCP 4608 P CPCP 4608 D

Choice of cylinders:

- 11" cylinder
- 8" cylinder

Choice of handle:

- Open grip with outside trigger
- "D" handle with inside trigger
- 1/2" inlet bushing

Item #	Blows Per Minute (bpm)	Cylinder Stroke (in.)	Length (in.)	Air Consump. (cfm)	Air Inlet (in.)	Chuck Size (Jumbo Shank)	Handle	Cylinder
CPCP 4608 P	1080	8	23	45	1/2	.890" x 1.125" Taper	Open grip - Outside trigger	Short cylinder
CPCP 4611 P	720	11	26	45	1/2	.890" x 1.125" Taper	Open grip - Outside trigger	Long cylinder
CPCP 4608 D	1080	8	23	45	1/2	.890" x 1.125" Taper	"D" handle - Inside trigger	Short cylinder
CPCP 4611 D	720	11	26	45	1/2	.890" x 1.125" Taper	"D" handle - Inside trigger	Long cylinder

CHICAGO PNEUMATIC CONSTRUCTION EQUIPMENT

Scabblers

Scabblers are ideal for cleaning and roughing concrete and construction joints; they can also be used to produce ornamental or contrasting finishes on building structures

CPCP 0006:

- Lightweight, compact tool with contoured grip handle reduces operator fatigue and increases output
- Tungsten carbide-tipped pistons last longer and are easily replaced
- Back head grip gives in-line thrust
- Chamfered cylinder block increases visibility of the work piece permitting close operation in tight corners



CPCP 0006

CPCP 0066:

- Lightweight, compact tool with contoured grip handle reduces operator fatigue and increases output
- Tungsten carbide-tipped pistons last longer and are easily replaced
- Chamfered cylinder block increases visibility of the work piece permitting close operation in tight corners
- All models - Air consumption at 90 psi: 29 cfm, 1/2" (NPT) air inlet thread



CPCP 0066

Item #	BPM per Piston	Bore (in.)	Stroke (in.)	Weight	Length	Height (Pistons Extended) (in.)	Width (in.)	Number/Type of Pistons
CPCP 0006	3000	1	10	16	7	4	Three 4-point carbide tipped	
CPCP 0066	3000	0	1	10	11	5	2	3



CHICAGO PNEUMATIC CONSTRUCTION EQUIPMENT

Combi Drills/Hammers

- These versatile tools are both a drill and a chipping hammer; a push of the rotation release button easily and quickly converts the tool to a hammer
- The CPCP 009 and CPCP 0014 RR rotary hammers are designed for a wide variety of construction and maintenance applications such as driving or setting masonry anchors and drilling holes in concrete, bricks or rock; as a hammer, these tools can be used for chipping, scarifying, scaling and cleaning welds

All Models:

- Excellent power-to-weight ratio helps drill holes faster and easier than comparable electric rotary hammers
- Built-in oiler provides continuous lubrication; teasing throttle for precise control
- Rotation release button converts tool to a hammer (except on CPCP 0009 AC)
- Cushioned piston for smooth operation and long tool life
- Muffler available to reduce noise

CPCP 009:

- Right hand rotation
- With an adaptor, can be used with electric hammer drill bits
- Spline version available
- Adapter (R137586) round to SDS

CPCP 0014:

- Superior drilling rates; Greater drilling capacity compared to plug hole drills - Designed for production drilling of small holes



Item #	Net Weight (lbs.)	Overall Length (in.)	Type of Chuck (in.)	Chuck Size (in.)
CPCP 0009 - Air consumption at 90 psi: 20 cfm, 3/8" (NPT) air inlet thread				
CPCP 0009 A	8	14 3/4	round shank	3/4 x 3 3/4
CPCP 0009 AC	8	14 3/4	round shank	3/4 x 3 3/4
CPCP 0009 F	8	14 3/4	spline drive	
CPCP 0014 RR - Air consumption at 90 psi: 32 cfm, 3/8" (NPT) air inlet thread				
CPCP 0014 RR	15	18 1/2	spring hex shank	7/8 x 3 1/4

CHICAGO PNEUMATIC CONSTRUCTION EQUIPMENT

Redhawk Gas Powered Breaker

- Tough and well designed, the Red Hawk is ideal for small jobs or for working in remote locations
- Use the rugged and versatile Red Hawk to: Break concrete; cut asphalt; dig
- Drive posts and fences; drive rods and spikes
- Tamp and compact soil; tamp ballast/ties
- Vibration-dampening handles have reduced vibration levels from 8 to less than 4.8 m/s²
- Engine Type: 185 cc 1-cylinder, 2-stroke
- Cooling: Forced air
- Impact rate: 2600 BPM
- Weight: 50.5 lbs.



Item #
CPRED HAWK

Gas Powered Drive Hammer - Combination Breaker & Drill

- Atlas Copco Cobra Combi gas powered drill/breaker

Includes:

- Replacement plug and starter rope, 1 liter oil, 1-3/8" drill steel x 16" length, 1-3/4" wide chisel x 13-1/2" length, carrying case & owners spare parts & safety manuals
- Chuck fits standard 7/8" x 4-1/4" hex detachable shanks

Item #
UTCC-78414





CHICAGO PNEUMATIC CONSTRUCTION EQUIPMENT

Chipping Hammers



CPCP 4123

CPCP 0012:

- Since the CPCP 0012 is light and has medium hitting power, it is very easy to handle and control for more precise jobs
- Typical applications include alteration work, hole making and trimming

CPCP 4123:

- The most popular chipping hammer; the CPCP 4123 is used for a wide variety of construction and industrial applications, from light to medium chipping to heavy cutting; choose the cylinder size that best suits your particular application
- Classic simplate valve; Heat treated cylinder; Now with spline lock instead of clip locking mechanism

CPCP 4125:

- The extra features of the CPCP 4125 make it more suitable for tough construction and industrial applications, including foundries, shipyards, refineries, or fabrication shops; even in hot, dirty working conditions, it will consistently hit hard and last longer than conventional hammers
- Unique ring valve as standard for harder blow in tough applications or dirty environments; Chrome plated cylinder for extra durability; Spline locking to prevent loosening of handle or cylinder

CPCP 4123 & CPCP 4125:

- Powerful, yet compact and lightweight; Rugged construction, hardened steel cylinder and handle; Teasing throttle for precise control; Open grip handle with self closing outside trigger
- Available in 2", 3" or 4" cylinder stroke versions
- Choice of bushing: .680" Round chisel rotates freely or .580" Hex prevents chisel rotation

CPCP 4130:

- Designed to tackle punishing jobs with the hard hitting power that you expect from CP
- It is used for medium-duty to heavy-duty chipping, cutting and trimming operations; the four bolt handle provides higher air flow and durability
- Locking mechanism with four high-strength 1/2" bolts; "D" handle with outside trigger and extra safety mechanism
- Muffler assembly as standard; Simplate valve for smooth operation; Available in 3" or 4" cylinder stroke versions
- Choice of bushing: .680" Round chisel rotates freely or .580" Hex prevents chisel rotation

CPCP 4132:

- A durable 4-bolt chipping hammer with inside trigger and standard retainer; available in two cylinder sizes to suite your particular application

Item #	Old Model Name	Weight (lbs.)	Cylinder Stroke	Length (in.)	Blows Per Minute (bpm)	Air Consump. (CFM)	Muffler Included As Standard	Chuck Size (in.)
CPCP 0012 2BR		12	2	16	2600	20	yes	.680" Rnd
CPCP 0012 2H		12	2	16	2600	20	yes	.580" Hex
CPCP 4123 2R	CPCP 4123 PYRA	13	2	12 ⁷ / ₈	2400	25	-	.680" Rnd
CPCP 4123 2H	CPCP 4123 PYRE	13	2	12 ⁷ / ₈	2400	25	-	.580" Hex
CPCP 4123 3R	CPCP 4123 PYSA	14 ¹ / ₄	3	14 ⁷ / ₈	1920	26	-	.680" Rnd
CPCP 4123 3H	CPCP 4123 PYSE	14 ¹ / ₄	3	14 ⁷ / ₈	1920	26	-	.580" Hex
CPCP 4123 4R	CPCP 4123 PYTA	15 ¹ / ₂	4	15 ¹ / ₂	1500	27	-	.680" Rnd
CPCP 4123 4H	CPCP 4123 PYTE	15 ¹ / ₂	4	15 ¹ / ₂	1500	27	-	.580" Hex
CPCP 4125 2R	CPCP 4125 PALA	13	2	13 ¹ / ₄	2400	26	-	.680" Rnd
CPCP 4125 2H	CPCP 4125 PALE	13	2	13 ¹ / ₄	2400	26	-	.580" Hex
CPCP 4125 3R	CPCP 4125 PAMA	14 ¹ / ₄	3	14 ¹ / ₄	1920	27	-	.680" Rnd
CPCP 4125 3H	CPCP 4125 PAME	14 ¹ / ₄	3	14 ¹ / ₄	1920	27	-	.580" Hex
CPCP 4125 4R	CPCP 4125 PANA	15 ¹ / ₂	4	15 ¹ / ₄	1500	28	-	.680" Rnd
CPCP 4125 4H	CPCP 4125 PANE	15 ¹ / ₂	4	15 ¹ / ₄	1500	28	-	.580" Hex
CPCP 4130 3R	CPCP 4130 3RO	18 ¹ / ₂	3	16 ¹ / ₂	1920	26	yes	.680" Rnd
CPCP 4130 3H	CPCP 4130 3HO	18 ¹ / ₂	3	16 ¹ / ₂	1920	26	yes	.580" Hex
CPCP 4130 4R	CPCP 4130 4RO	19 ¹ / ₂	4	17 ³ / ₄	1500	27	yes	.680" Rnd
CPCP 4130 4H	CPCP 4130 4HO	19 ¹ / ₂	4	17 ³ / ₄	1500	27	yes	.580" Hex
CPCP 4132 3R		15	3	17	1800	33.23	-	.680" Rnd
CPCP 4132 3H		15	3	17	1800	33.23	-	.580" Hex
CPCP 4132 4R		15	4	17	1800	33.23	-	.680" Rnd
CPCP 4132 4H		15	4	17	1800	33.23	-	.580" Hex



CHICAGO PNEUMATIC CONSTRUCTION EQUIPMENT

Backfill Tampers



- Quickly and effectively compact soil around foundations and other structures and are indispensable for compacting backfill in trenches
- The CPCP 0003 is well equipped to handle light to medium applications while the CPCP 0004 is ideal for heavier jobs
- Maximum power - slow, powerful blows efficiently and quickly compact all types of backfill, including clay and soils containing high percentages of finely crushed or powdered material
- Heat-treated cylinder and chrome plated piston significantly extend tool life; Adjustable packing maintains a positive air seal
- Aluminum butt held with clamp screw for quick, easy replacement; Exhaust deflector directs air, moisture and oil away from operator
- Integral oiler continuously lubricates tool during operation; Well-balanced, smooth-operating tool is easily guided by one person
- 1/2" (NPT) air inlet thread
- For quieter operation, optional mufflers are available

Item #	Valve Type	Bore & Stroke (in.)	Blows Per Minute (bpm)	Net Weight (lbs.)	Overall Length (in.)	Piston Rod Body Dia. (in.)	Piston Rod Butt Size (in.)
CPCP 0003 - Air consumption at 90 psi: 18 cfm							
CPCP 0003	Simplex	1 1/16 x 6	800	30	52	7/8	5
CPCP 0004 - Air consumption at 90 psi: 28 cfm							
CPCP 0004	Ring	2 1/4 x 6	780	42	50	1	6 1/4



ATLAS COPCO
Pneumatic Breakers

HAPS Vibration Reduction TEX PE Series



- Highly efficient silencing and vibration dampening systems make PATTEX PE breakers comfortable to operate and the most productive choice for demanding jobs
- The ergonomic design of the PATTEX PE series breakers equipped with HAPS® (Atlas Copco's Hand-Arm Protection System), means they can be used for prolonged periods with minimum risk to the operator's health

Atlas Copco's HAPS® System:

- By reducing the in-use vibration value of the breaker, Atlas Copco's HAPS system decreases the negative effects of harmful vibration at a given trigger time
- The PE series pneumatic breakers allow up to 7 times the trigger time of conventional fixed-handled tools at a given level of operator vibration-exposure
- Data at 6 bar (90 psi) air pressure

Item #	Tool Shank (in.)	Weight (lbs.)	Air Consump. (CFM)	Length (in.)	Impact Frequency (blows/min.)
PATTEX 150PE	1 x 4 1/4	40	53	23	1530
PATTEX 190PE	1 x 4 1/4	50	55	24	1500
PATTEX 230PE	1 1/8 x 6	60	64	26	1320
	1 1/4 x 6	60	64	26	1320
PATTEX 280PE	1 1/8 x 6	70	68	27	1230
	1 1/4 x 6	70	68	27	1230
PATTEX 33PE	1 1/8 x 6	81	74	29	1200
	1 1/4 x 6	81	74	29	1200
PATTEX 40PE	1 1/8 x 6	93	83	30	1110
	1 1/4 x 6	93	83	30	1110



ATLAS COPCO
Pick Hammers

Low Weight - High Productivity



- The PATTEX 09 and 12 series pick hammers are one of the lightest and most productive medium-weight tools in their class; They are fitted with D-type handles
- The SOFTSTART two-step trigger feature lets the operator start slowly with full control over the chisel starting position and placement
- PS = Equipped with threaded, cap-type tool retainer for more comfortable handgrip when performing horizontal tasks; PSK = Equipped with kick-latch type tool retainer for quick and easy tool changing; S = Silenced

Item #	Tool Shank (in.)	Weight (lbs.)	Air Consump. (CFM)	Length (in.)	Impact Frequency (blows/min.)
PATTEX 09PS	7/8 x 3 1/4	21	39	20	1800
PATTEX 09PSK	7/8 x 3 1/4	23	39	21	1800
PATTEX 12PSK	7/8 x 3 1/4	27	21	1800	

ATLAS COPCO
Ergonomic Scaler



- Ruggedly built, the PATTEX 117 is a low maintenance, long reach scaler perfect for many surface-cleaning operations
- Using a variety of standard accessories, the operator can chip concrete, grout, caulking or remove tiles, mastic, paint and roofing materials
- The ergonomic long reach scaler reduces time-consuming hand scraping and back breaking labor; it is economical to use, consuming only 7 cfm, and can operate from a small portable compressor
- Includes 4" wide chisel - 9245 9987 67

Item #	Desc.	Weight (lbs.)	Air Consump. (CFM)	Length (in.)	Impact Frequency (blows/min.)
PATTEX 117	Floor Scraper	17	7	70	2300

ATLAS COPCO
Rock Drills



- The ergonomically designed PATBBD 15E and PATRH 572E, medium-weight rock drills with high power-to-weight ratios, provide maximum operational safety and productivity; these low maintenance drills deliver high impact energy in relation to weight, and have ergonomic features that improve operator comfort and safety
- The PATBBD 15E and PATRH 572E are equipped with spring-dampened handles that reduce vibration transmissions to the operator's hands by more than 75%; PATBBD 15ET has a lever operated throttle control
- Sound suppressors reduce low-frequency noise levels by 7 dB(A) - more than 50%; the combination minimizes operator fatigue and raises productivity
- The PATRH 572E features rifle-bar rotation, a slower rotation and lower impact frequency for drilling in hard rock
- This drill is ideal for minor bench drilling and other rock drilling applications
- The lighter PATBBD 15E has ratchet-wheel rotation, with faster rotation and higher impact frequency, for drilling in soft to medium-hard rock; the PATBBD 15E is designed for concrete drilling, drilling for smooth blasting and seam drilling - all applications that demand a high-performance, lightweight, easy-to-handle drill
- Penetration Rate: Drilling in granite with 1-1/8" chisel-type integral drill-steel (working at 90 psi)

Item #	Weight (lbs.)	Air Requirement (CFM)	Length Incl. Drill-Steel Retainer (in.)	Drill-Steel Chuck (hex) (in.)	Impact Frequency (blows/min.)	Rotation Speed (r/min.)	Penetration Rate (in./min.)	Hose Connection (in.)
PATBBD 15E	34	47	22 3/4	3/4 x 4 1/4	2520	220	8 3/4	5/8
	34	47	22 3/4	7/8 x 3 1/4	2520	220	8 3/4	5/8
	34	47	22 3/4	7/8 x 4 1/4	2520	220	8 3/4	5/8
PATBBD 15ET	34	47	22 3/4	7/8 x 4 1/4	2520	220	8 3/4	5/8



ATLAS COPCO
Light Rock Drills



- The lightweight PATBBB 12 hand-held rock drill is the perfect partner in a wide variety of applications where maneuverability and easy handling are important
- Available in two models, one for horizontal drilling and one for vertical-down drilling, the PATBBB delivers powerful, reliable and flexible operation
- Equipped with a D-type handle, the PATBBB 12D is ideal for horizontal drilling, plug hole drilling in concrete to a maximum depth of 3 feet
- For vertical-down drilling to 10 feet in depth, Atlas Copco offers the PATBBB 12T, with slightly-angled T-type handle, to provide the best grip
- The PATBBB 12T is perfect for concrete drilling, drilling for smooth blasting, and seam drilling; all PATBBB models are equipped with kick-latch type drill-steel retainers for safe, quick and easy steel changes
- Horizontal Penetration Rate: Drilling in granite with 1-1/8" chisel-type integral drill-steel (working at 90 psi)
- Vertical-Down Penetration Rate: Drilling in granite with 1-1/4" chisel-type integral drill-steel (working at 90 psi)

Item #	Weight (lbs.)	Air Requirement (CFM)	Length Incl. Drill-Steel Retainer (in.)	Drill-Steel Chuck (hex) (in.)	Impact Frequency (blows/min.)	Rotation Speed (r/min.)	Penetration Rate (in./min.)	Hose Connection (in.)
Horizontal								
PATBBB 12D	22	51.1	22¼	¾ x 4¼	2580	220	10	½
PATBBB 12DS	24	46.9	22¼	¾ x 4¼	2520	220	8	½
Vertical-Down								
PATBBB 2T-01	24	51.1	20	7/8 x 4¼	2580	220	6	½
PATBBB 12TS-01	27	46.9	20	7/8 x 4¼	2520	220	6	½



AJAX TOOLS
Air Hammer Chisels

**1/2" Square Shank
Weld Flux**

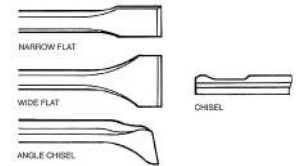

- 1/2" square shank
- 7" length

Item #	Desc.	Width (in.)
AJ382	Flat	¾
AJ383	Scaling	1¾
AJ384	Angle	1¾

AJAX TOOLS
Air Hammer Chisels

Zip Gun

- All listed chisels have .401" round shank with round retainer

Item #	Desc.
AJ907	Claw Ripper — Edging Tool
AJ908	Muffler Cutter
AJ909	Panel Cutter
AJ910	Flat Chisel, ¾ Blade
AJ910-1/2	Flat Chisel, ¾ Blade
AJ911	Taper Punch
AJ913	Straight Punch
AJ922	Angle Chisel

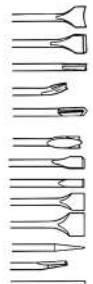

AJAX TOOLS

AJAX TOOLS

Air Hammer Chisels

.680" Round Shank-Oval Collar



- .680" round shank oval collared

Item #	Desc.	Width (in.)	Length (in.)	Wt
AJ303	Flat	1	9	1.25
AJ303-12	Flat	1	12	
AJ303-18	Flat	1	18	2.5
AJ303-24	Flat	1	24	
AJ313	Moil	-	9	
AJ315-12	Moil	-	12	1.5
AJ315-24	Moil	-	24	
AJ325	Scaling	1½	9	1.25
AJ325-12	Scaling	1½	12	1.5
AJ325-18	Scaling	1½	18	
AJ323	Scaling	2	9	
AJ323-12	Scaling	2	12	1.75
AJ307	Round Nose	¾	9	

AJAX TOOLS

Spline Drive Accessories

Chiseling and Chipping



- Scaling Chisel
- 5/8" Round spline shank for large rotary hammer with spline drive; 12" length

Item #	Width (in.)	Wt
AJ5009	2	2.25
AJ5012	3	2.25

AJAX TOOLS

Replacement Scaler Needles

Set of 19

- Replacement needle for needle scaler
- Diameter: 1/8"; Length: 7"

Item #	UoM
AJ1377	St



AJAX TOOLS

Shank Rivet Sets

- .401 Shank Rivet Sets

Item #	Size (in.)	Head
AJ1605	¼	Round
AJ1621	¼	Brazier

NO IMAGE AVAILABLE

AJAX TOOLS

Paving Breaker Tools



1" X 4-1/4" Hex

Item #	Desc.	Length (in.)
AJ22100	Narrow Chisel	18
AJ22200	Moil Point	18
AJ23300	3" Wide Chisel	18
AJ28400	Asphalt Cutter 5"x6"	6

AJAX TOOLS

Paving Breaker Tools



1-1/8" X 6" Hex

Item #	Desc.
AJ30010	Bushing Tool 2" x 2"
AJ31060	Frost Wedge 1 7/8" x 12"
AJ31080	Digging Chisel 3" x 10"
AJ32100	Narrow Chisel 18"
AJ32200	Moil Point 18"
AJ32300	3" x 18" Wide Chisel
AJ38400	Asphalt Cutter 5" x 6"
AJ39500	Clay Spade 5 1/2" x 6 1/2"

AJAX TOOLS

Paving Breaker Tools



1-1/4" X 6" Hex

Item #	Desc.
AJ41200	Moil Point 14"
AJ42200	Moil Point 18"
AJ47200	Moil Point 72"
AJ42100	Narrow Chisel 18"
AJ43100	Narrow Chisel 24"
AJ42300	Wide Chisel 3" x 18"
AJ43300	Wide Chisel 3" x 24"
AJ48400	Asphalt Cutter 5" x 6"
AJ49500	Clay Spade 5 1/2" x 6 1/2"

AJAX TOOLS

Concrete & Masonry Demolition Hammer Bits

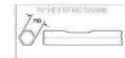

5218



5209

3/4" Hex Shank

- For 3/4" hex shank demolition hammers
- Fits Makita HM1211B and DeWalt DW551K

Item #	Desc.	Width (in.)	Length (in.)	Dia.	Wt
AJ5209	Scaling Chisel	2	12	¾	1.75
AJ5218	Bushing Tool	1 3/8 Sq.	9 1/4	¾ Hex	2.7



AJAX TOOLS

Electric Hammer Chisels



5/8" Round Spline Shank

- For large rotary hammers with spline drive

Item #	Desc.	Length (in.)	Width (in.)
AJ5016	Clay Spade	15½	4½

AJAX TOOLS

Electric Hammer Chisels

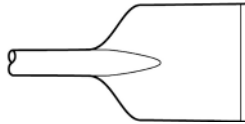

3/4" Hex Demo Shank

- For demolition hammers which use 3/4" hex accessories

Item #	Desc.	Length (in.)	Width (in.)
AJ5220	Asphalt Cutter	15½	5

AJAX TOOLS

Electric Hammer Chisels



SDS Max Shank

- For large rotary hammers with SDS-Max drive

Item #	Desc.	Length (in.)	Width (in.)
AJ5801	Moil Point	12	1
AJ5803	Moil Point	18	1
AJ5805	Flat Chisel	12	-
AJ5816	Clay Spade	15½	4½
AJ5820	Asphalt Cutter	15½	3½

AJAX TOOLS

Prick Punch



Item #	Size (in.)
AJ592	¾ x 5

AJAX TOOLS

Pry Bars with Handles



Item #	Size (in.)	Width
AJ675-12	¾ x 12	¾
AJ675-18	½ x 25	[11x16]

AJAX TOOLS

Pinch Bars



Item #	Size (in.)
AJ682	7/8 x 36

AJAX TOOLS

Steel Stock Wedges



Item #	Height (in.)	Width (in.)	Length (in.)
AJ882	½	1	6
AJ884	1	1½	8

AJAX TOOLS

Ground Rod Driver

1-1/4" X 6" Hex

NO IMAGE
AVAILABLE

- Driving electrical grounding rods into the soil

Item #	Hole Size (in.)	Rod Size (in.)
AJ41758	¾	¾



GREENLEE TEXTRON INC.

HPD Series Sign Post Drivers

**Hydraulic
Fairmont**



- Can drive a variety of post sizes from small delineator posts up to 3-1/2" round posts including square, "U" channel, breakaway stubs, round, "T" fence, and wood
- Quick change front head design accommodates adapters for different types of posts
- A deep post opening and smooth operation ensures that the driver will not jump off of posts
- Available with integral trigger or remote on/off valve

Item #	Desc.
GRHPD-T-U	Sign post driver with integral trigger with universal post adapter
GRHPD-HV-U	Sign post driver with remote on/off valve with universal post adapter
GRUA	Universal post adapter
GRRA96	3.8" round post adapter
GRSA54	2½" square post adapter
GRF020196K	HTMA Female Coupler - ½" NPTF internal thread
GRF020197K	HTMA Male Coupler - ½" NPTF internal thread
GR1803065	12" Hose Assembly
GR54923	HTMA Female Coupler
GR54924	HTMA Male Coupler
GR1803066	12" Hose Assembly
GR111952	Remote Valve



GREENLEE TEXTRON INC.

Pole Tampers

**Hydraulic
Fairmont**



- Makes quick work of setting poles, asphalt patch and general construction backfill compacting
- Only three moving parts for low maintenance
- Kidney-shaped foot included
- Hose End Valve - Reversible on/off valve for open-center and closed-center hydraulic systems
- Valve on Tube - Rotate trigger spool for open-center and closed-center hydraulic systems

Item #	Desc.
GRH4802	60" Pole Tamper, Hose End Valve
GRH4802-6	60" Pole Tamper, Hose End Valve (unit does not include on/off valve)
GRH4802-1	85" Pole Tamper, Hose end Valve
GRH4802-5	60" Pole Tamper, Valve on Tube
GRH4802-3	72" Pole Tamper, Valve on Tube
GR111964K	Kidney-Shaped Foot
GR111952	Remote Valve

GREENLEE TEXTRON INC.

Sign Post Puller

**Hydraulic
Fairmont**



- Uses serrated jaws or wraparound, high-strength alloy chain
- Able to pull most any post size and shape
- Faster and easier than conventional manual methods

Includes pulling chain

Specifications:

- System: Open-Center
- Lift Capacity: 9,800 lb. (4,445 kg)
- Stroke: 5" (127 mm)
- Chain: 9/32" (7.1 mm) alloy
- Weight: 70 lb. (31.8 kg)

Item #
GRH4905A

GREENLEE TEXTRON INC.

Pole Puller Hydraulic Fairmont



- Heavy-duty construction
- Works in confined areas, next to buildings, or out in the open
- Proof-certified 6' (1.8 m) alloy chains included

Specifications:

- System: Open-center and closed-center
- Lift Capacity: 56,000 lb. at 2,000 psi
- Chains: 5/8" proof-certified alloy
- Weight: Cylinder only: 101 lb., with base and chain: 178 lb.

Item #
GRH4910A

GREENLEE TEXTRON INC.

Impact Wrenches Fairmont



- Added power and torque for heavy-duty jobs
- Twin hammer design
- Can be used on either open-center or closed-center system
- Adjustable torque control

Item #	Desc.
GRH6510A	3/4" Impact Wrench - 3/4" Square Drive
GR48330	1/2" Impact Wrench

GREENLEE TEXTRON INC.

Impact Wrenches and Drills 7/16" Hex Hydraulic Fairmont



- Twin-hammer impact mechanism provides high performance and reliability
- Button to switch between forward and reverse rotation
- One-piece handle and impact housing casting provide long life
- Super Spool™ permits quick switches between open-center and closed-center hydraulic systems
- Heat-insulated handle, ergonomically positioned for comfort; well balanced for comfortable operation
- Most durable and longest life of any 1/2" wrench on the market
- Includes the 49314 heavy-duty adapter; toughest adapter on the market

Item #	Desc.
GRH8508-1	High torque 1/2" impact wrench with 7/16" hex quick-change chuck and 49314 heavy-duty adapter
GRH8508-1V	High torque 1/2" impact wrench with flow control, 7/16" hex quick-change chuck and 49314 heavy-duty adapter
GRH8508-3	Moderate torque 1/2" impact wrench, 7/16" hex quick-change chuck and 49314 heavy-duty adapter
GRH8508-3V	Moderate torque 1/2" impact wrench with flow control, 7/16" hex quick-change chuck and 49314 heavy-duty adapter



GREENLEE TEXTRON INC.

Reversible Drill Hydraulic Fairmont



- Rugged gear motor; reversible
- Compact, lightweight – ideal for line construction applications
- Super Spool™ selector control for use on open-center and closed-center hydraulic systems

Capacity:

- Steel: 1/2" hole; wood 1-1/6" hole

Item #	Desc.
GRH6400C	Drill - 1/2" key-type chuck

GREENLEE TEXTRON INC.

Compact Submersible Water Pumps 2" Pump Fairmont



- Self-priming, compact, lightweight design with carrying handle
- Can draw water down to depth of 1-3/4"; can run dry w/o damage

Specifications:

- System: Open-center and closed-center
- Capacity: Up to 275 gpm (at 7 gpm and a 10' head height)
- Flow Range: 5 - 8 gpm; Operating Pressure: 0 - 2,000 psi

Item #
GRH4665A

GREENLEE TEXTRON INC.

Standard Chain Saws Hydraulic Fairmont



- Ideal for large trimming applications and cut-up removal jobs
- Chain and bar can be adjusted without removing sprocket cover
- Handle position can be oriented to horizontal, or to 60° or 30° relative to bar and chain to user preference (except on model with chain brake)
- Rugged gear motor and expanded chip exit area
- Automatic chain oiler can be adjusted without tools
- Safety Features Include: Two-step safety trigger, high impact polymer front handle/shroud, wide lower handle protects hands/knuckles, chain catcher stops chain rotation
- Reduced kickback bar and chain
- Supplied with 12" (305 mm) steel braided whip hoses (couplers not included)
- Chain brake models meet requirements of ISO 6535

Item #	Desc.	Cutting Capacity (in.)	Weight (lbs.)	Length (in.)
GRHCS816	Chain Saw	16	9.5	31.5
GRHCS820	Chain Saw	20	10.2	35.5
GRHCS8160CB	Chain Saw w/ Chain Brake	16	9.5	31.5

GREENLEE TEXTRON INC.

Long-Reach Chain Saws



Hydraulic Fairmont

- Cuts hard-to-reach branches from aerial basket or from the ground
 - Super Spool™ selector control for use on open-center and closed-center hydraulic systems
 - Available in three lengths
 - Insulated fiberglass extension tubes, tested to meet OSHA Regulation 1910.269
 - Safety features include: two-step trigger, trigger guard, and fully covered sprocket guard
 - Anti-kickback chain and automatic chain oiler
 - Unfilled and foam-filled extension tube versions offered
- Specifications:

- Cutting Capacity: 13"
- System: Super Spool™ selector control for use on open-center and closed-center hydraulic systems
- Extension Type: Fiberglass-tested to 100 KvA for 5 minutes

Item #	Desc.	Length (in.)	Weight (lbs.)
GR43178	Long Reach Chain Saw	62.5	8½
GR38568	Long Reach Chain Saw	75	9¼
GR43177	Long Reach Chain Saw	88.5	9¾
GRLRF75	Foam Filled Long Reach Chain Saw	75	9½
GRLRF88	Foam Filled Long Reach Chain Saw	88.5	10¼

GREENLEE TEXTRON INC.

Hydraulic Power Unit



20 Hp Fairmont

- Electric key-start 20 hp Honda OHV engine with low-oil shutdown
- Variable oil flow to 10 gpm (38 lpm)
- Oversized oil cooler and electric fan ensures cool running
- Engine hour meter and tachometer
- Hydraulic oil level sight gauge and 10 micron oil filter
- Tubular frame protects components and allows easy access to maintenance points
- Integral grab rails for lifting the unit into trucks and trailers
- Heavy-duty lifting eye
- HTMA flat-face hydraulic couplers
- Easy access service points for engine oil, fuel, battery, and oil filter
- Sealed lead-acid battery

Specifications:

- Horsepower: 20 at 3,600 rpm (14.9 kW at 3,600 rpm)
- System: Open-center
- Rated Flow: 5 - 10 gpm; Rated Pressure: 2,000 psi
- Fuel: Gasoline 3.3 gal.; Hyd Oil Capacity: 3.1 gal.
- Dry Weight: 259 lb.
- Length: 34"; Width: 31"; Height (handle folded): 32"

Item #
GRF20



GREENLEE TEXTRON INC.

Hydraulic Flow Control Valve

Fairmont



- Operates off other equipment's hydraulic accessory circuit—no need for a separate power unit
- Accepts up to 30 gpm for running off most skid-steer, tractors and loaders
- Variable flow adjustment allows precise flow control for tool operation; integral pressure relief valve helps protect hydraulic equipment and tools
- All-aluminum body design is lightweight and provides better heat dissipation; low profile, compact unit is unobtrusive and easy to install.
- All tool ports have O-Ring boss and accept industry standard hoses and couplers

Specifications:

- Hydraulic Ports: Power Source Side – Pressure: 1-1/16" NPT – SAE O-Ring Boss
- Power Source Side – Return: 1-1/16" NPT – SAE O-Ring Boss
- Tool Side – Pressure: 3/4" - 16 SAE O-Ring Boss HTMA Flush Face Coupling
- Tool Side – Return: 3/4" - 16 SAE O-Ring Boss HTMA Flush Face Coupling
- Maximum Output Flow: 10 gpm; Maximum Output Pressure: 2,150 psi
- Temperature Range: -30° to 140° F
- Maximum Input Flow: 30 gpm; Maximum Input Pressure: 3,000 psi

Item #
GRHFC30

GREENLEE TEXTRON INC.

Breaker - 45 lb. and 55 lb.

Hydraulic
Fairmont



- Great for breaking sidewalks and curbs or driving ground rod, and for other small demolition jobs
- Clean modular design with few protrusions to irritate operators' legs
- High blow energy provides maximum breaking power
- Integral rubber damper reduces chisel noise
- Low noise and vibration levels
- AVS tools have patented spring-dampened handles that reduce vibration transmitted to the operator by 80%-90%
- Two-step trigger
- Supplied with 12" (305 mm) steel braided whip hoses

Item #	Desc.
GRHPB45-1AVS	Breaker-- 1 1/8 x 6" tool shank size, cushioned/spring-dampened handles
GRHPB45-2AVS	Breaker-- 1 X 4 1/4" tool shank size, cushioned/spring-dampened handles
GRHPB55-1AVS	Breaker-- 1 1/8 x 6" tool shank size, cushioned/spring-dampened handles



TSURUMI PUMPS

Garden Hose Utility Pump

- Air-filled motor
- Built in float switch for automatic or manual operation
- 1.25" discharge with garden hose adapter
- Suitable for all your general dewatering applications
- Built in float switch allowing you to operate the pump automatically or manually depending on the situation



Item #	Discharge Bore (in.)	Cable Length (ft.)	Diameter (in.)	Height
TSUF-13	1 1/4 & 1 1/2	10	7 3/4	12 1/8



MULTIQIP INC

Gasoline-Powered Trash Pumps

- Rugged and dependable, they are ideal for dewatering applications with high solid content
- Sticks, stones and debris easily pass through the pump, minimizing downtime due to clogging
- Self-priming design
- Silicone seals stand up to harsh jobsite environments
- Large easy cleanout



Item #	Desc.
MQQP2TH	2" Trash, 211 GPM, Honda GX160

MULTIQIP INC

4-Cycle Gasoline Rammers

- Improved self-cleaning clutch design
- Built-in hourmeter/tachometer
- Unique throttle control
- Advanced air filtration system
- Poly fuel tanks and heavy duty PVC guards and covers
- Quiet, EPA-approved engine
- Advanced anti-vibration handle design
- Convenient rollers for easy loading
- Laminated wood and steel shoe absorbs and withstands shock and stress



Item #	Desc.
MQMTX70	Honda GX100, 3350 lbs force 11.2" shoe



TPI CORPORATION
Belt Drive Portable Blower

Standard & Swivel

- Swivel model rotates 360° in 12.5° increments and locks in place with a steel locking pin
- 10" hard rubber wheels
- Size - 36", 42" and 48"
- Motor - 1-speed, permanently lubricated ball bearing; Switch - Rocker on 115V 1 Phase models
- ETL listed; Meets OSHA standards
- 1 Year Limited Warranty



Item #	Blade Size (in.)	CFM	Amps	Weight (lbs.)	Motor Type	Motor HP	RPM	Base
TPIPB-36-B	36	14500	8.0	120	120 V 1 PH ODP	1/2	500	Standard
TPIPBS-36-B	36	14500	8.0	145	120 V 1 PH ODP	1/2	500	Swivel
TPIPB-42-B	42	18200	11.0	135	120 V 1 PH ODP	3/4	430	Standard
TPIPBS-42-B	42	18200	11.0	160	120 V 1 PH ODP	3/4	430390	Swivel
TPIPB-48-B	48	22700	15.0	155	120 V 1 PH ODP	1	390	Standard
TPIPBS-48-B	48	22700	15.0	180	120 V 1 PH ODP	1	390	Swivel

TPI CORPORATION
Direct Drive Portable Blower

Standard & Swivel

- Swivel model rotates 360° in 12-1/2 increments and locks in place with a steel locking pin
- 8"/10" rubber wheels
- ETL Listed; Meets OSHA Standards
- 1 Year Limited Warranty



Item #	Blade Size (in.)	CFM	Amps	Shipping Wt.	Motor	Base
TPIPB-36-D	36	12500	5.5	82	1/3	Standard
TPIPBS-36-D	36	12500	5.5	110	1/3	Swivel
TPIPB-42-D	42	15600	6.0	102	1/2	Standard
TPIPBS-42-D	42	15600	6.0	128	1/2	Swivel
TPIPB-48-D-OP	48	17300	10.3	117	3/4	Standard
TPIPBS-48-D-OP	48	17300	10.3	142	3/4	Swivel

TPI CORPORATION
Mini-Blower

Floor Model

- Size - 24" and 30"
- Cord - SJT type, 3 conductor, 10 ft. long
- Blade - Aluminum; Guards - Spiral wire - front and rear
- Housing - Powder coated 20 ga. steel
- Motor - 2-speed, 1/4 HP, 1 Phase, 115 volt, ball bearing, permanently lubricated, totally enclosed, permanent split capacitor
- Switch - Rotary on floor model, rocker on 30" floor model with wheels and pull chain on yoke mounted model
- UL - Listed; Meets OSHA Standards; 1 Year Limited Warranty

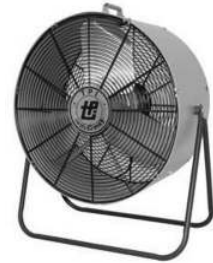

Item #	Blade Size	CFM	Amps	Shipping Wt.
TPIMB-24-DF	24	6800	2.2	52
TPIMB-30-DF	30	7800	2.5	58



TPI CORPORATION
Fan Forced Milkhouse Heater

- Heat settings plus fan only setting
- Temperature control thermostat
- 6' long - 3 conductor cord
- Triple safety system: Tip over switch, Automatic reset type limit control, Thermal cut-off device



Item #	Volts	Watts	Phase	Max. BTU's/Hr.
TPI188TASA	120	1500/1300 Fan Only	1	5120

TPI CORPORATION
**Combination Radiant
& Fan Forced Heaters**

- 3-Heat settings
- Temperature control thermostat
- Dual safety system: Tip over switch, Manual reset type limit control
- 6' long - 3 conductor cord



Item #	Volts	Watts	Phase	Max. BTU's/Hr.
TPI198TMC	120	1500/900/600	1	5120



ALLEGRO INDUSTRIES
**8" AC Axial Blower
Metal Housing & Canister**

- AC axial blower w/canister
- Engineered for convenience, this 8" axial blower is an all-in-one ventilation system
- Design allows ducting to collapse into a built-in canister for easy storage
- Includes blower, build-in storage canister and 25 ft. of ducting
- Free Air Flow: 1275 CFM, Air Flow with One 90° Bend: 661 CFM, Air Flow with Two 90° BendS: 582 CFM
- Power Rating: 3A/115V; Wt.: 46 lbs.



Item #	Desc.
ALL9514-25	25 ft. of Ducting

ALLEGRO INDUSTRIES
8" Duct to Duct Connector

- Allows safe connection of additional ducting; Constructed of galvanized steel with raised lip to hold in place

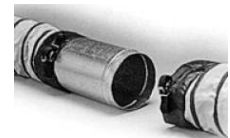

Item #
ALL9500-01



ALLEGRO INDUSTRIES
**8" AC COM-PAX-IAL
Plastic Blower**



With Canister & 25' Ducting

- Features the 8" Com-Pax-Ial blower with canister and 25' ducting
- Designed with the quick-connect clipping system which allows workers to attach the canister, tools-free, to the input side for powerful extraction or output side for ventilation
- The 25' ducting stores conveniently within the canister
- Built-in carry handles, built-in On/Off switch and "Safety" orange coloration
- Free Air Flow: 831 CFM, Air Flow with One 90° Bend: 709 CFM, Air Flow with Two 90° Bends: 586 CFM
- Power Rating: 3A/115V; Power Cap.: 1/3 hp; Wt.: 38 lbs.

Item #	Desc.
ALL9533-25	25 ft. of Ducting

ALLEGRO INDUSTRIES
**8" Plastic Explosion
Proof COM-PAX-IAL
Blower with Ducting**



- 8" COM-PAX-IAL AC explosion proof blower with canister and 25' statically conductive ducting
- Electric explosion-proof motor is UL/CSA listed
- Single-phase motor includes NEMA rated 115V plug for use with explosion-proof socket (sold separately)
- Meets Class I, Divisions 1 and 2, Groups C and D and Class II, Divisions 1 and 2, Groups F and G Hazardous Location Requirements
- Free Air Flow 900 CFM, Air Flow with One 90° Bend: 650 Cfm, Air Flow with Two 90° Bends: 625 CFM
- Power Rating 115V; Power Cap.: 1/3 hp; Wt.: 44lbs.

Item #
ALL9538-25

ALLEGRO INDUSTRIES
Blower Ducting

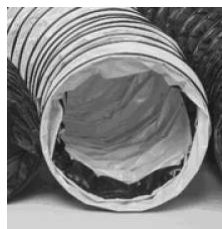

- Lightweight and retractable - vinyl and polyester materials with PVC coating
- Designed for maximum air handling capabilities and built for dual direction flow
- Yellow with black weatherstrip for visibility on the job; 25 ft. of 8" diameter

Item #	Desc.
ALL9500-25	25 ft. of 8 in. Duct

ALLEGRO INDUSTRIES
Axial Inlet Adapter



- Allows an axial blower to draw fumes and other contaminants out of work area
- Can be used on any Allegro 8" metal axial blower and allows blower to work on two completely different applications

Item #
ALL9500-03

Edge rents & repairs all types of equipment including hydraulic & gas-powered.

**Need something you don't see?
Call Edge & we likely have it or will be able to source it!**



L.B. WHITE
Forced Air LP/NG Heaters
Tradesman®



- LP and NG models available
- Ultra models include Self Diagnostic Service Saver for convenient trouble-shooting
- Dependable electronic spark ignition; Superior Tri-Shield finish provides extended protection against abrasion and corrosion
- Thermostatic temperature control (Tradesman 170, 400 models); Adjustable front leg provides easy direction of heat (170,400 models)
- Variable output saves fuel; Direct-fired = 99.97% fuel efficiency
- CSA US, (all models) and Canada (all except 100K)

Item #	Btu/h Rating	Heated Air Output (CFM)	Fuel Consumption (max.) LP Gas (lbs./hr.)	Fuel Consumption (max.) Natural Gas (cu.ft./hr.)	Amps (starting/continuous operation)	Service Saver
LB100	50,000-100,000	350	4.6		4.7/2.0	
LB170	125,000 - 170,000	625	7.2	170	3.7/2.4	
LB170Ultra	125,000 - 170,000	625	7.2	170	3.7/2.4	Yes
LB400	250,000 - 400,000	1,582	18.5		3.7/2.4	
LB400Ultra	250,000 - 400,000	1,582	18.5		3.7/2.4	Yes

L.B. WHITE
Forced Air Kerosene Heaters
Tradesman®



- Kerosene, #1 diesel or #1 fuel oil
- Durable brass fuel fittings, not plastic; Dependable, dual-prong electronic spark ignition
- Fuel gauge indicates remaining run time; Comfort control thermostat
- Threaded drain plug; Wheels and handles make it easier to maneuver
- CSA US and Canada

Item #	Btu/h Rating	Heated Air Output (CFM)	Pump Pressure (psi)	Fuel Consumption (max.) (gal./hr.)	Tank Cap. (gal.)	Operating Time/Tankful (hrs.)	Amps (continuous operation)	Motor Horsepower	Dimensions (LxWxH/in.)	Shipping Weight (lbs.)
LBK170	170,000	600	6.5	1.3	13	10.0	3.2	¼	43.5x23.9x26.6	60.0
LBK400	400,000	1,400	125	3.0	29	9.5	4.4	½	52.5x32.0x34.0	155.0
LBK650	650,000	3,600	110	4.9	50	10.0	7.1	¾	69.2x30.7x48.7	298.0



ENERCO®
Forced Air Propane Heater
For Small Worksites
HeatStar



- Propane gas; Flame safety
- Pressure regulator settings: 28" W.C.; Adjustable height control; Continuous ignition
- High temperature limit switch: 240° F; Power Required: 115 V 60 Hz 3A
- Propane Hose - 20 ft.: 3/8" I.D. w/Regulator and POL; POL/Excess flow check valve
- HS85FAV heats up to 2,000 square feet and operates up to 8 hours on a 20 lb. tank
- HS125FAV heats up to 3,000 square feet and operates up to 11 hours on a 40 lb. tank

Item #	Output BTU/hr	Output CFM	Min. LP Tank Size (lb.)	Propane Consump. (lbs/hr)	Shipping Size LxWxH (in.)	Net Weight (lbs.) (Includes Hose/Regulator/POL Assembly)	Shipping Weight (lbs.)	Shipping Cube (ft.)
HS85FAV	50,000-85,000	300	20	2.3 to 3.9	21x11.5x16	18	20	2.2
HS125FAV	75,000-125,000	350	40	3.5 to 5.8	20.25x12x15.5	23	25	2.7



ENERCO®

Forced Air Propane Heater

For Large Jobsites



- Propane gas; Flame Safety
- Min. LP Tank Size: 100 lb.; High temperature limit switch: 240° F
- Automatic solid state ignition; Built-in thermostat
- Power Required: 115 V 60 4A; POL/Excess flow check valve
- HS170FAVT has adjustable height control, heats up to 4,000 square feet and operates up to 17 hours on a 100 lb. tank
- HS400FAVT heats up to 9,000 square feet and operates up to 17 hours on a (2) 100 lb. tanks

Item #	Stock Number	Output BTU/hr	Output CFM	Propane Consump. (lbs/hr)	Pressure Regulator Settings	Propane Hose - 20 ft.	Shipping Size LxWxH (in.)	Net Weight (lbs.)(Includes Hose/Regulator/POL Assembly)	Shipping Weight (lbs.)	Shipping Cube (ft.)
HS170FAVT	F170170	125,000-170,000	450	5.8 to 7.8	28" W.C.	3/8" I.D. w/Regulator & POL	26.5x11.5x16.75	32	34	3.0
HS400FAVT	F172425	250,000-400,000	1400	11.5 to 18.5	20 PSI	1/4" I.D. w/Regulator & POL	38.58x15x22.25	47	51	7.5

ENERCO®

Forced Air Kerosene Heaters

For Large Jobsites

HeatStar



- Heavy construction; Illuminated on-off switch
- Enclosed motor; Large heavy-duty handles; Cord wrap; Fuel gauge
- 10" Pneumatic tires; High output fan; Larger "glove-friendly" controls

Specifications:

- Tank Capacity (GAL - L): 14/52; Flame Safety/Overheat Safety Shutoff; Continuous Ignition
- Power Required: 110-115 V 60 Hz; Tires/Wheels: 10" Pneumatic
- Shipping Size (LxWxH): 42"x18"x22"
- Multi-Fuel (No. 1 or No. 2 Diesel Oil, Kerosene, JP-8 or Jet A)

Item #	Stock Number	Output BTU/hr	Heating Area (sq. ft.)	CFM Output	Fuel Consump. (Gal./hr. - L/hr.)	Operating Hours On Full Tank	Shipping Weight (lbs.)
HS125KT	F170325	125,000	3,000	275	.77/2.91	15	74
HS175KT	F170375	175,000	4,250	400	1.15/4.35	10	81
HS210KT	F170380	210,000	6,000	400	1.60/6.05	8	87

ENERCO®

Convection Heaters

HeatStar



Special Features:

- Piezo push button ignitor; Adjustable Heat Output
- "Insta-Lock" system for easy assembly - no tools

Specifications:

- Fuel: Propane Gas
- Flame Safety: Thermocouple operated gas valve; Standing Pilot; Piezo ignition
- Power required: None; POL/Excess flow check valve

Item #	Stock Number	Output BTU/hr	Propane Consump. (lbs/hr)	Pressure Regulator Settings	Hose - 20 ft.	Shipping Size LxWxH (in.)	Net Weight (lbs.)(Includes Hose/Regulator/POL Assembly)	Shipping Weight (lbs.)	Shipping Cube
HS80CV	F170480	30,000-80,000	1.4 to 3.7	11" W.C.	3/8" I.D. w/Regulator & POL	15.25x18.25x21.75	19	21	3.50
HS200CV	F170600	75,000-200,000	3.5 to 9.3	10 PSI	1/4" I.D. w/Regulator & POL	18.25x15x27.5	25	27	4.36



ENERCO®
**Single Tank-top
Propane Heater**

w/ Piezo Ignitor
HeatStar



- Variable output of: 8, 12 & 14,000 BTU/hr
- Hi-Medium-Low Regulator
- Safety shutoff; Operates 30-52 hours on a 20 lb. tank
- Connects to a 20 lb. cylinder

Item #	Stock Number
MH12T	F273100

ENERCO®
**Double Tank-top
Propane Heater**

w/ Piezo Ignitor



- Variable output of: 8, 12, 16, 24 & 28,000 BTU/hr
- Two safety shutoffs
- Hi-Medium-Low Regulator
- Run on one burner or two
- Operates 17-52 hours on a 20 lb. tank
- Connects to a 20 lb. cylinder

Item #	Stock Number
MH24T	F273600



UNION TOOLS
Dual Wheel Wheelbarrow



- 8 cu. ft. poly tray
- Front tray braces, "H" brace and steel cross strips
- Two 16" pneumatic 2-ply tire and oil lube bearings
- Wood handles

Item #
UF77-315

UNION TOOLS
**Contractor Grade
Wheelbarrow**



- 6 cu. ft. heavy gauge seamless steel tray
- Front tray braces, "H" brace, steel cross strips and leg pads
- 16" pneumatic 2-ply tire with oil lube bearings
- Wood handles

Item #
UF77-306

UNION TOOLS
**Poly Tray Wheelbarrow
With Pour Spout & Steel Handles**



- 6.5 cu. ft. poly tray with pour spout
- Reinforcing ribs, front tray braces and "H" brace
- 16" pneumatic 2-ply tire with oil lube bearings
- Steel handles

Item #
UFC6UPSP



MARATHON INDUSTRIES

Wheelbarrow Tire

Flat Free

- Solid flat free polyurethane tire
- 500 lb. capacity
- Size 4.80/4.00-8"
- 6" hub, 5/8" bearing, 15-1/2" diameter



Item #	Style
MRT00001	Solid Ribbed
MRT00047	Solid Knobby



COLUMBUS MCKINNON CORP.

Hookaroons

36" Hickory handle

- Ergonomically designed for specific tasks within a high production mill environment, providing a task oriented design when extreme light weight and durability are required



Item #	Head Style
CM12220	1.5 Dixie Standard

COLUMBUS MCKINNON CORP.

Pike Poles

Aluminum Handles

- Manufactured to withstand extensive use of handling timber in and around water
- All pike hooks are manufactured from a single piece of high carbon steel and drop forged
- Will not warp or break with continued use



Item #	Length (ft.)
CM10082	6
CM10002	8
CM10012	10
CM10022	12
CM10032	14
CM10042	16
CM10052	18
CM10062	20
CM10072	24



DIAMOND PRODUCTS
Complete Drill Rigs

Combination

- The most lightweight rig of any in its class (combo stand, wheel kit and switch box weighs just 52 lbs.)
- 12" bit capacity (up to 36" with spacers and hydraulic motor and power jack)
- Easy quick-disconnect motor mount
- Angle drilling capability up to 45°
- Easily adjustable slide bearings
- Longer columns available up to 60"
- Quick release vacuum button
- Double column support for increased stability
- 4-spoke sliding handle (can be used on either side)
- Convenient easy carrying handle (ceiling jack available)



Motor:

- 20 amp core bore CB748, RPM: 350/900

Safety Override:

- Slip clutch

Item #
DP4220003

DIAMOND PRODUCTS
Hand Held Core Drill
WEKA DK12

- Hand held and portable



Item #	Desc.	RPM	Safety Override
DP4244017	WEKA DK12, 14 AMP	580/1400/2900	Slip Clutch

DIAMOND PRODUCTS
Complete Drill Rigs

Light Weight
M1-AA-15

- 15 amp, 3.5HP
- 6 inch bit capacity
- Weighs only 45 lbs.
- 15 amp, 3.5 HP Core Bore Motor
- Single speed - 800 RPM
- Water hose connection
- Spring loaded slide handle for easy coring
- Includes a water trap ring



Item #
DP4220050

DIAMOND PRODUCTS
Complete Drill Rigs

Combination
M-1

- 1" to 10" bit capacity (14" with one spacer)
- Dual switch/outlet control panel & amp meter
- Streamlined base and carriage
- 2-1/2" square column with black oxidized finish
- Quick changeover from vacuum to anchor base



Item #	Desc.	RPM	Safety Override
DP4245055	20 Amp Core Bore	350/900	Slip Clutch

DIAMOND PRODUCTS
Drill Rig Accessories

Vacuum Pumps

- Gast vacuum pumps mount easily and run quietly, we have pumps designed for each of our rigs or choose a pump for an all-purpose base



Item #
DP4244077

DIAMOND PRODUCTS
Complete Drill Rigs

Combination
M-4

- Weighs only 35 lbs. (rig -20 lbs., motor -15 lbs.)
- 6" bit capacity (3" handheld)
- Converts to hand held drill motor in seconds
- Combination Stand quickly angles to 45 degrees
- 3-speed hand held drill motors with overload clutches
- Mast can rotate 360 degrees on swivel stand
- Reversible slide handle (use on left side or right side of rig)



Item #	Desc.	RPM	Safety Override
DP4240001	14 Amp WEKA DK12	580/1400/2900	Slip Clutch

Accessories

DP4240020	M-4 Drill Stand
-----------	-----------------



DIAMOND PRODUCTS
14" Masonry Saw

- Powerful 3 HP motor
- 14" blade capacity
- Tool-free air filter replacement
- Saw head adjusts easily
- Longer motor life due to a superior air filter
- Includes 2 spare air filters
- Blade not included
- Power Supply: 115V/60Hz
- Power: 2 Horsepower
- Amp Draw: 15 Amp
- RPM: 3600
- Blade Capacity: 14"
- Max. Depth of Cut: 5"
- Max Length of Cut: 16"
- Material Size: 8" x 8" x 16"
- Weight: 80 lbs.
- Saw Height: 24"
- Saw Length: 28"
- Saw Width: 23"



Item #
DPCC300M

DIAMOND PRODUCTS
Masonry Saw

Electric

Masonry electric saws have dual run and start capacitors for minimal amp draw at start up. Our high torque motors use a premium start capacitor box with a sealed manual thermal overload reset. Our 2.5 HP motor is the largest dual voltage motor in its class. We outfitted our motor with a convenient front facing voltage switch and a side mounted water pump outlet.

- Legs standard on all saws
 - Water pump standard on all electric models
 - Easy, safe access to depth control lock
 - 2.5 HP electric motor is strongest dual-voltage motor on the market
 - Stay level guard
 - Side carrying handles
- Amp draw: 2.5 HP - 21.0 amps @ 115V.
*All electric motors are single phase.



Item #
DP46901

DIAMOND PRODUCTS
Cut-Off Saw

SpeediCut

- Sturdy die-cast magnesium foot
- Rubber cushioned full wrap-around handle



Item #
DP44071

DIAMOND PRODUCTS
Concrete Saw

Center Cut Design

- Cyclone air cleaner for increased engine longevity
- Front and rear pointers
- Polyurethane wheels with roller bearings and grease zerks
- Quick release folding handle
- Cutting depth up to 2-1/4" with 8 inch blade
- Power transmission to blade drive is via 2 molded notch 3VX premium belts - for better cutting performance and longer belt life
- Center cut design - Better tracking into an existing cut and easy to keep the cut straight
- Self adjusting dust guard
- 1" arbor with greaseable bearings



Item #
DP46851

DIAMOND PRODUCTS
Concrete Saw

Our patented ratchet raise and lower system is the fastest, easiest way to place the blade into and out of the cut. It has 11 depth settings to choose from which automatically lock in place when the handgrip is released. Settings are in 1/2" increments.

- Large wheels for easy mobility over curbs and rough surfaces
- Removable handles for easy storage
- Blade coolant is delivered from an innovative dual multi-spray water tube system which gets coolant to both sides of the blade from the arbor to the top of the blade
- Power transmission to blade drive is via 3 molded notch 3VX premium belts - not 2, like some of our competitors, resulting in better cutting performance and longer belt life
- 4-5/8" cutting depth with 14" guard

Specifications:

- Maximum Depth of Cut: 4-5/8"
- Blade Shaft: 3,000 RPM
- Blade Shaft Diameter: 1"
- Arbor Size: 1" diameter with single drive pin



Item #
DP02276



DIAMOND PRODUCTS
Push Saw

Our patented ratchet raise and lower system is the fastest, easiest way to place the blade into and out of the cut. It has 17 depth settings to choose from which automatically lock in place when the handgrip is released. Settings are in 1/2" increments.



- Positive lock screw feed raise and lower mechanism allows precision blade depth and feed adjustment
- Power transmission to blade drive is via 3 molded notch 3VX premium belts - not 2, like some of our competitors, resulting in better cutting performance and longer belt life
- Handle adjusts to saw operators height
- Available with 14" or 18" blade guard
- 6-5/8" cutting depth with 18" guard
- Left or right hand sawing

Specifications:

- Maximum Depth of Cut with 14" Blade: 4-5/8"
- Blade Shaft: 2,600 RPM
- Blade Shaft Diameter: 1-1/4"
- Arbor Size: 1" diameter with single drive pin

Item #
DP25181

DIAMOND PRODUCTS
Walk Behind Concrete Saws
CC1200



- Heavy-duty design
- Slip-on blade guard
- Depth indicator
- 6-5/8" maximum cutting depth
- 18" Maximum blade capacity
- Left or right hand sawing

Item #	Engine Type	Blade Capacity (in.)
DP5800630	9 HP Robin-Subaru	14
DP5800631	9 HP Robin-Subaru	18
DP5800632	9 HP Honda	14
DP5800633	9 HP Honda	18
DP5800636	13 HP Honda	14
DP5800637	13 HP Honda	18

DIAMOND PRODUCTS
Concrete Saws

Walk Behind

- Screw feed raise and lower mechanism
- Handle adjusts to saw operators height
- Available with push or hydrostatic transmission choices
- Variety of power options in gasoline, electric or hydraulic up to 20 HP
- Left or right hand sawing

†Electric start

*Includes remote cyclone air cleaner



Dimensions:

- Saw height with handlebar: 37-1/2"
- Min. length pointer up: 36"
- Max. length pointer down: 72"
- Saw height without handlebar: 33-3/4"
- Frame width: 16"
- Frame length: 30-5/8"
- Saw width: 22-3/8"

Item #	Model No.	Engine Type	P/N - 20 in. Model
DP47029	CC1818BV-S	18 HP Briggs Vanguard †	5800327
DP25180	CC1820H-S	20 HP Honda †*	5800333



HUSQVARNA
Gas Powered Cutoff Saw



- Cuts concrete and masonry in alteration, renovation and new construction work
- Cuts curbstones and pavers in landscaping
- Pipe cutting in installation work
- Asphalt cutting in roadwork and pre-cutting in pipe trenches
- Metal cutting
- Blade: 14/16 in.
- Cutting Depth : 5/6 in.
- Power : 6.4 hp

Item #
PRK970-14
PRK970-16



HUSQVARNA
Gas Cutoff Saw



- Cuts concrete and masonry in alteration, renovation and new construction work
- Cuts smaller holes and adjusts window and door openings
- Cuts curbstones and pavers in landscaping
- Pipe cutting in installation work
- Asphalt cutting in roadwork and pre-cutting in pipe trenches
- Metal cutting
- Blade Dia.: 12/14 in.
- Cutting Depth: 4/5 in.
- Power: 5 hp

Item #
PRK760-12
PRK760-14

HUSQVARNA
Electric Cutoff Saw



- Made for cutting indoors and outdoors
- Ideal for quick and easy cutting of building block, pipe, reinforcement bar, supports, etc
- Easily adjusts between cutting different materials
- Blade: in. (mm) 14 (350)
- Cutting Depth: 5 in.
- Electric Motor: 120 vac
- Rated Output: 1,800 watt
- Rated Current: 15 amp

Item #
PRK3000WET14

HUSQVARNA
Electric Cutoff Saw



- Efficient electric cutter with convenient method for cutting up to 16" deep
- An excellent choice for flush cutting, i.e. cutting tight against walls and floors
- Blade Diameter: 9 in.
- Cutting Depth: 16 in.
- Electric motor: 120 v.
- Rated Output: 1800 watt
- Rated current: 15 amp

Item #
PRK3000CUT-N-BREAK

HUSQVARNA
Wet Cutting Kit



- For older power cutters, a wet cutting kit is available as an accessory
- The nozzles distribute the water evenly over the blade

Item #
TA505-09-54-03

HUSQVARNA
Soff-Cut 2000



- Applications:
- Ultra Early Entry™ concrete cutting system reduces random cracking
 - Designed for heavy-duty usage on highways, runways and paving applications
 - Three blade widths can be used, allowing different joint widths and crack control simultaneously.

- Benefits:
- Self Propelled gasoline saw with hydrostatic transmission
 - Electronic remote key start and choke
 - Mechanical remote retractable guide
 - Cyclonic air filter to increase engine longevity
 - Patented dry-cut diamond blade, anti-ravel skid plate and safety arbor

- Technical specifications:
- Maximum blade diameter, in (mm): 10 (254)
 - Maximum depth of cut, in (mm): 1-1/2 (38)
 - Maximum power, hp*: 9
 - Average bladeshaft, rpm: 3600

Item #
PR966845301

HUSQVARNA
Soff-Cut 150



- Applications:
- Ultra Early Entry™ concrete cutting system reduces cracking
 - Designed for residential and light commercial applications

- Benefits:
- Gasoline saw with easy pull start engine
 - Mechanical blade depth control
 - Retractable front guide system

- Technical specifications:
- Maximum blade diameter, in. (mm): 6 (152)
 - Maximum depth of cut, in. (mm): 1-3/16 (30)
 - Maximum power, hp*: 4.3
 - Average bladeshaft, rpm: 3,800

Item #
PR966844801



HUSQVARNA
**Excel 1000 Series
Purple**

**Ultra Early Entry™ Saw
Blades**

- The Husqvarna Excel 1000 Series Purple is recommended for ultra hard aggregate, non-abrasive sand



Item #	Size-Inches (mm)	Blade
542777005	6 (152)X.100	XL6-1000
542756137	8 (203)X.100	XL8-1000
542756100	10 (254)X.100	XL10-1000
542756105	12 (305)X.100	XL12-1000
542756164	12 (305)X.220	XL12S22-1000
542756112	13½ (343)X.120	XL14-1000

HUSQVARNA
MS355 14" Portasaw



Applications:

- Smaller jobs for cutting brick, block or pavers

Benefits:

- New replaceable rails make alignment of cart easier
- New design has wider opening in back to allow larger material to pass through
- Saw head comes preassembled to frame
- High torque continuous duty 115/208-230 dual voltage electric motor provides high power and long life
- Only two pivot points for reduced saw maintenance and longer diamond blade life
- Plunge cut or lock the head and use with the rolling cart
- The optional foot pedal kit reduces operator fatigue when plunge cutting
- Sta-level® bladeguard keeps parallel to the cutting table for accurate cuts
- The side handles make moving the saw easier
- Pivot lock bar moved to front for convenient raise/lower operation of blade

Item #	Blade Dia. (in.)	Power (hp)	Arbor Size (in.)
PR966006503	14	2	1

Folding Stand

PR034040

Adaptor Cord 20A Twist to 15A Straight

PR173120

HUSQVARNA

Cut-n-Break Blades



- PREL 10 CnB (shown) is for cutting cured concrete with hard to medium-hard aggregate and has a U-shaped segment design which improves cooling and slurry transportation, for better blade speed
- PREL 35 CnB is a general purpose blade that will cut hard material such as river rock, granite, heavily reinforced concrete, mica, precast panels, marble, quartz, trap rock, flint rock, and concrete over 6,000 psi tensile strength
- PREL 70 CnB cuts concrete block, green concrete, limestone, lava rock, slaterock, shale, and sandstone; it is also suitable to cut through very abrasive, softer material - this blade has an excellent speed and life in all abrasive concrete
- The Cut-n-Break blade sets have a depth of 16" for wet cutting only
- The total segment height for these sets is .295" diamond depth

Item #
PREL 10 CnB
PREL 35 CnB
PREL 70 CnB

Edge rents
and repairs
equipment.

Call for a
demo.



HUSQVARNA
Cut-n-Break Concrete Saw

K 760



- Ideal for window and door openings where you don't want overcutting at the corners
- Deep cutting up to 16"; cuts pipes in pipe trenches, grooves for cabling, expansion joints and crack repair
- Excellent for cutting when burying signal cables
- Specially developed, twin 9" blades provide high cutting speed and power
- Active Air Filtration™, centrifugal air cleaning, extends product life and service intervals
- SmartCarb™, a built-in automatic filter compensation, maintains high power and lowers fuel consumption
- EasyStart™ provides 50% easier starts
- DuraStarter™ reduces wear on the starter
- Easy view fuel indicator shows the fuel level in the tank
- Air-cooled 2-stroke engine
- Fuel indicator in the tank
- Easy-adjust blade guard
- Wet kit
- One set of Cut-n-Break blades included
- Designed for wet cutting only

Item #	Blade (in.)	Power (hp)	Power/Weight Ratio (hp/lbs.)	Displacement (cu in.)	Weight, with out fuel and cutting equip. (lbs.)	Fuel Capacity (qt.)	Sound Power Level dB(A)	Sound Pressure Level dB(A)	Vibrations Front Handle Equivalent (m/s ²)	Vibrations Rear Handle Equivalent (m/s ²)
PRK 760	9	5	.22	4.5	23.3	.95	113	97	3.2	5.7

HUSQVARNA
Cut-n-Break Concrete Saw

K 3000



- Efficient electric cutter with convenient method for cutting up to 16" deep
- An excellent choice for flush cutting, i.e. cutting tight against walls and floors
- Well suited for indoor use and smaller jobs where you want to avoid overcutting at the corners
- Ideal for cutting pipes in trenches, grooves for cabling, expansion joints and for crack renovation
- Specially developed, twin 9" blades provide high cutting speed and power
- The ergonomic front handle facilitates both vertical and horizontal cutting
- The convenient, patented design of the rear handle makes operation easier
- Adjustable blade guard enables flush cutting
- Elgard™, the advanced electronic overload protection system, varies the rotation speed to warn of an approaching overload
- Electronic Softstart™ provides starting with normal, slow-acting fuses
- Generously dimensioned miter gear provides high durability, minimal power loss and low noise levels
- One set of Cut-n-Break blades included
- Simple blade change
- Wet kit

Item #	Cutting Depth (in.)	Electric Motor (volt)	Rated Output (watt)	Rated Current (amp)	Weight Without Blade (lbs.)	Sound Power Level Lwa, dB(A)	Sound Pressure Level dB(A)	Vibrations Front Handle Equivalent (m/s ²)	Vibrations Rear Handle Equivalent (m/s ²)
PRK 3000	9	16	120	1,800	18	108	95	3.2	3.4



HUSQVARNA
Gas Powered Walk Behind Flat Saw
FS 627 20



- Ideal for medium to small service and repair jobs when cutting concrete or asphalt
- Fully enclosed transmission
- Lift bail is standard on all models

Item #	Max. Blade Diameter (in.)	Max. Depth Of Cut (in.)	Average Bladeshift (rpm)	Blade Flanges (in.)	Power Source	Max. Power HP*/Engine Manufacturer
PRFS 627 20	20	7½	2,400	4	Gasoline	27/Kohler

HUSQVARNA
Gas Powered Walk Behind Flat Saw
FS 400



- Ideal for small road repair jobs in concrete or asphalt
- Cutting trenches for pipe laying
- Making expansion joints in concrete floors
- Cutting channels for impedance loop fittings or cable laying
- Max Power is 11 HP
- Honda engine
- Gasoline power source

Item #	Max. Blade Diameter (in.)	Max. Depth Of Cut (in.)	Average Bladeshift (rpm)	Blade Flanges (in.)
PRFS 400	18	6½	2,800	4½

HUSQVARNA
Diesel Powered Walk Behind Flat Saw
FS 4800 D 30



- For jobs such as airports, highways, service work and other applications where production is a concern
- Ideal for mid-size to small jobs that require high production rates when cutting depth is no more than 15"

Item #	Max. Blade Diameter (in.)	Max. Depth Of Cut (in.)	Average Bladeshift (rpm)	Blade Flanges (in.)	Power Source	Max. Power HP*/Engine Manufacturer
PRFS 4800 D 30	30	12	1,600	5	Diesel	48/Yanmar

HUSQVARNA
Diesel Powered Walk Behind Flat Saw
FS 6600 D 36



- Large jobs such as airports, highways, larger service work and other applications where production is a concern
- Ideal for mid-size and smaller jobs that require high production rates

Item #	Max. Blade Diameter (in.)	Max. Depth Of Cut (in.)	Average Bladeshift (rpm)	Blade Flanges (in.)	Power Source	Max. Power HP*/Engine Manufacturer	Power At Bladeshift (HP)
PRFS 6600 D 36	20	7½	2,400	5	Diesel	66/John Deere	60



DIAMOND PRODUCTS
Dry Turbo Saw Blades

- Faster cutting, lower cost version of our original outstanding turbo blade
- Designed for use of right-angle grinders, high speed, portable, electric, masonry and tile saws
- Smooth cutting from our advanced, high density metal bond technology and our unique segment design
- Cuts brick, block, concrete pavers, concrete, marble and stone

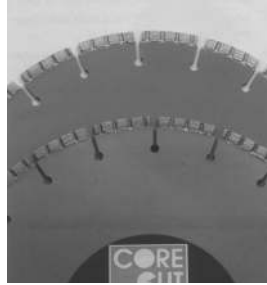

Item #	Size	Desc.
DP11709	12 in. x .125	Gold HP Dry Turbo Blade
DP11711	12 in. x .125 x 20mm	Gold HP Dry Turbo Blade
DP11666	14 in. x .125	Orange HP Dry Turbo Blade

DIAMOND PRODUCTS
Dry Saw Blades

Small Diameter

- For use on hand-held circular saws and most right-angle grinders
- Diamond blade maintains a constant depth of cut with fewer blade changes than abrasive blades
- Provide fast, free cutting in concrete, block, marble, soft granite, stone, tile and other materials



Item #	Size	Blade Type
DP23754	4 in. x .070	Green
DP23857	4½ in. x .070	Green
DP11344	4 in. x .070	Gold
DP11352	6 in. x .080	Gold
DP11242	4 in. x .070	Orange
DP11268	7 in. x .080	Orange

DIAMOND PRODUCTS
Pointing Saw Blades

Dry Tuck

- HD orange general purpose dry tuck pointing blades
- For use on hand-held circular saws and small, right-angle grinders



Item #	Size
DP12418	4" x .250
DP12446	7" x .250

DIAMOND PRODUCTS
Bit Extension Rod

Steel

- Made of durable steel
- Length: 12"
- Fits Bit Size: Up to 1-1/2"



Item #
DP4400005

DIAMOND PRODUCTS
Adapters

Steel

- Made of durable steel



Item #	Top Thread	Bottom Thread Male
DP4400008	1.250"-7 Female	5/8 in. - 11
DP4400009	5/8 in. - 11 Female	1.250 in. - 7
DP4400011	1/2 in. - 20 Female	
DP4400033	1/2 in. Straight Male Shank	5/8 in. - 11
DP4400037	1/2 in. BSP Male	5/8 in. - 11

Call an Edge sales representative for help with your specific application.



DIAMOND PRODUCTS
Core Bits

Premium Black

- Our premium black bit is the industry standard; it's very high diamond concentration gives maximum footage and drilling speed
- Designed for all types of wet drilling; good in moderate to high steel applications



Item #	Size (in.)
--------	------------

Fast Cutting concrete with high steel core bit

DP27319	1/2
DP21536	5/8
DP21537	3/4
DP21538	7/8
DP14369	1
DP19582	1 1/8
DP20066	1 1/4
DP23775	1 3/8
DP05434	1 1/2
DP20264	1 5/8
DP43724	1 3/4
DP45949	1 7/8
DP05520	2
DP23876	2 1/4
DP05602	2 1/2
DP23877	2 3/4
DP05649	3
DP23878	3 1/4
DP05700	3 1/2
DP05748	4
DP23824	4 1/4
DP05802	4 1/2
DP05836	5
DP05864	5 1/2
DP05884	6
DP30187	6 1/4
DP22049	6 1/2
DP22049	7
DP05976	8
DP06012	9

DIAMOND PRODUCTS

Core Bits

Heavy-Duty Orange

- Has a high diamond concentration for excellent footage and cutting speed
- Designed for all types of wet drilling in applications with light to moderate steel
- HOL-General purpose, fast cutting



Item #	Size (in.)
--------	------------

DP04812	1
DP04837	1 1/8
DP15509	1 1/4
DP15525	1 1/2
DP15479	2
DP04959	2 1/4
DP00004	2 1/2
DP00005	3
DP05032	3 1/4
DP00006	3 1/2
DP00007	4
DP00008	4 1/2
DP00009	5
DP00010	6

DIAMOND PRODUCTS

Dry Diamond Hole Saws

- Drill dry through block and brick in seconds; no water needed for easy cleanup

Dry hole saw notes:

- Not all types of brick and block drilled
- All bits have 5/8"-11 threads
- All bits have 9" drilling depth



Item #	Diameter (in.)	Drill Grinder	
		Minimum (Amps)	Max/Min (RPM)

DP04706	1	6	6000/2300
DP04717	1 1/2	7	5000/1600

DIAMOND PRODUCTS

High Speed Saw Blades

Segmented Dry

- Economy green dry high speed blades
- The most competitively priced on the market; designed for fast, smooth cutting in many materials; may be used wet or dry
- More constant depth of cut and far fewer blade changed compared to abrasive blades; great for cutting concrete, concrete curbing, brick or block walls, expansion joints, precast and prestressed materials and much more
- Application - General purpose long life



Item #	Size(in)
--------	----------

DP26137	12x.110
DP26420	14x.110



DIAMOND PRODUCTS
Dry Turbo Saw Blades

Economy

- Economy green turbo blades
- Designed for use on right-angle grinders, high speed, portable electric, masonry and tile saws
- Advanced, high-density metal bond technology and high diamond concentration
- Long life and smooth cutting in the widest range of materials
- Application: General purpose, smooth cutting, long life



Item #	Size	Desc.
DP23755	4 in. x .080	Green Turbo Blade
DP12489	7 in. x .095	Gold Dry Turbo Blade
DP12286	4½ in. x .080	Orange Dry Turbo Blade
DP12290	5 in. x .080	Orange Dry Turbo Blade
DP12292	6 in. x .080	Orange Dry Turbo Blade
DP12298	7 in. x .095	Orange Dry Turbo Blade
DP12319	12 in. x .125	Orange Dry Turbo Blade
DP12327	12 in. x .125 x 20mm	Orange Dry Turbo Blade
DP12331	14 in. x .125	Orange Dry Turbo Blade

DIAMOND PRODUCTS
High Speed Saw Blades

Heavy-Duty Orange Dry

- Designed for fast, smooth cutting in smooth, cutting in many materials
- More constant depth of cut and far fewer blade changes compared to abrasive blades
- Great for cutting concrete, concrete curbing, brick or block walls, expansion joints, precast and prestressed materials and much more



Item #	Size (in.)
DP53729	12x.110
DP53735	12x.125
DP53737	14x.110
DP53741	14x.110
DP53742	14x.125
DP53743	14x.125

DIAMOND PRODUCTS

Masonry Saw Blades

- For the contractor who wants to make intermittent cuts without water for patch/repair work or expansion joints
- Much more efficient than abrasives for speed and consistent depth
- Our .125 wide blades may now be used on high speed cutoff saws



Item #	Size	Desc.
DP11156	12 in. x .125	HD Orange Asphalt Blade
DP11162	14 in. x .125	HD Orange Asphalt Blade
DP44889	8 in. x .125 x 1	Early Entry Orange Blade
DP44490	8 in. x .125 x 1	Early Entry Orange Blade

DIAMOND PRODUCTS

High Speed Saw Blades

Imperial Purple

- High quality, long life
- General purpose cutting in hard materials
- Dry or wet cutting



Item #	Size (in.)
H8I - General purpose	
DP85149	
DP78976	
DP96480	
H10I - Asphalt, brick and block	
DP15376	
DP15379	
DP15381	

DIAMOND PRODUCTS

Dry Grinders

Spiral Turbo Cup

- The most efficient way to grind all types of concrete, masonry, brick, block and stone
- Ring cup grinder is ideal for beveling, smoothing and shaping concrete, masonry and stone surfaces
- May be used on most right-angle grinders
- Note: All cup grinders come with 5/8"-11 threaded arbor

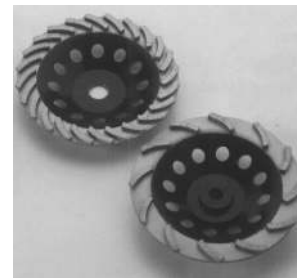

Item #	Desc.	Side Rail Length (ft)
DP17943	Orange Spiral Turbo Cup Grinder with 10 Segs	4" x 5/8"-11
DP15096	Orange Spiral Turbo Cup Grinder with 24 Segs	7" x 5/8"-11



DIAMOND PRODUCTS
Standard Gold

Cup Grinders

The most efficient way to grind all types of concrete.



Item #	Size	Style
DP07442	4" x 5/8"-11	Single Row
DP07429	4" x 5/8"-11	Double Row
DP07439	4" x 5/8"-11	Ring
DP28508	5" x 5/8"-11	Single Row
DP07431	5" x 5/8"-11	Double Row
DP07450	7" x 5/8"-11	Single Row
DP07434	7" x 5/8"-11	Double Row

DIAMOND PRODUCTS
Standard Gold

Turbo Cup Grinders

- Angled segments for faster grinding
- General grinding and medium removal
- Spiral turbo for a fast grind



Item #	Size
DP17846	4" x 5/8"-11 (9 seg)
DP23177	4" x 7/8" (9 seg)
DP16410	7" x 5/8"-11 (12 seg)
DP17834	7" x 7/8" (12 seg)
DP15263	7" x 5/8"-11 (24 seg)

DIAMOND PRODUCTS
Star Blue

Cup Grinders

The most efficient way to grind all types of concrete.



Single Row:

- General grinding

Double Row:

- General grinding with smooth finish

Item #	Size	Style
DP77383	4" x 5/8"-11	Single Row
DP77502	4 1/2" x 5/8"-11	Single Row
DP77542	7" x 5/8"-11	Single Row
DP70360	4" x 5/8"-11	Double Row
DP70387	4 1/2" x 5/8"-11	Double Row
DP70391	7" x 5/8"-11	Double Row



HUSQVARNA
General Purpose Grinding Cups



Premium Dry Cutting

- Silicon carbide specification wheel is used for general purpose work; concrete and masonry products, cast iron, ductile iron and titanium
- For fast, efficient grinding and long life
- Grinding cup wheels include steel backs for increased safety

Item #	Size
TA22984	4" x 2" x 5/8"-11
TA40S006	5" x 2" x 5/8"-11
TA40S10	6" x 2" x 5/8"-11

HUSQVARNA
General Purpose Abrasive Blades

Concrete/Masonry Dry Cutting

- For general purpose cutting of concrete and masonry materials
- Outstanding speed, blade life and cost efficiency



Item #	Size
TA23019	12" x 1/8" x 1"
TA23020	12" x 1/8" x 20mm
TA23021	14" x 1/8" x 1"
TA23022	14" x 1/8" x 20mm

HUSQVARNA
General Purpose Abrasive Blades

Metal Dry Cutting

- For general purpose blade for cutting metal
- Outstanding speed, blade life and cost efficiency



Item #	Size
TA23023	12" x 1/8" x 1"
TA23024	12" x 1/8" x 20mm
TA23025	14" x 1/8" x 1"
TA23026	14" x 1/8" x 20mm



HUSQVARNA
**General Purpose
Abrasive Blades**

Cast/Ductile Iron Dry Cutting

- For general purpose cutting of cast iron and ductile iron
- Outstanding speed, blade life and cost efficiency



Item #	Size
TA23027	12" x 1/8" x 1"
TA23028	12" x 1/8" x 20mm
TA23029	14" x 1/8" x 1"
TA23030	14" x 1/8" x 20mm

HUSQVARNA
**General Purpose
Abrasive Blades**

Asphalt Dry Cutting

- For general purpose asphalt cutting blade
- Outstanding speed, blade life and cost efficiency



Item #	Size
TA23033	14" x 5/32" x 1"

HUSQVARNA
**High-Speed Concrete
Abrasive Blades**

Super Premium Dry Cutting

- Will cut most concrete and masonry
- Blades have maximum performance featuring a unique grain/bond formula that is flat-woven and triple reinforced for added strength



Item #	Size
TA24511211	12" x 1/8" x 1"

HUSQVARNA
Shaft Extensions



Item #	Thread	Size (in.)
TA541201737	1 1/4"-7	12
TA541400067	1 1/4"-7	6
TA541400070	5/8"-11	6

HUSQVARNA
**High-Speed Metal
Abrasive Blades**

Super Premium Dry Cutting

- Metal cutting blade
- Blades have maximum performance featuring a unique grain/bond formula that is flat-woven and triple reinforced for added strength



Item #	Size
TA25511111	12" x 1/8" x 1"
TA25411111	14" x 1/8" x 1"

HUSQVARNA
**Threaded Shaft
Adapters**

Item #	Female	Male
TA541201736	1 1/4"-7	5/8"-11
TA541404610	5/8"-11	1 1/4"-7



HUSQVARNA
**45° Bevel Tuckpoint
Saw Blades**

General Purpose Dry/Wet

- The 45° Bevel Tuckpoint blade is used for crack chasing and mortar removal between brick and block
- A great multi-purpose blade for the restoration market
- V-shaped segments leave a clean groove for easy filling and repair



Item #	Size
TA520031	4" x .375 x 7/8 - 5/8 B
TA520032	7" x .375 x 7/8 - 5/8 B

HUSQVARNA
**Super Premium
Diamond Blades**
**General Purpose Dry/Wet
Cutting
HI Series**

- HI5 - fast cutting of a wide variety of materials on the first pass, such as cured concrete and brick; only all-purpose diamond blade with aggressive notched segments which grab and grind material for a rapid first cut
- HI9 - cuts green concrete with soft to medium aggregate and provides long life



Item #	Desc.	Size
TA542774540	HI5	12" x .125 x 1" DP -20mm B
TA542774541	HI5	14" x .125 x 1" DP -20mm B
TA581291	HI9	14" x .125 x 1" DP -20mm B



HUSQVARNA

DT5+ Tuckpoint Saw Blades

General Purpose Dry/Wet

- The DT5+ soft bond blade is used to quickly remove mortar between brick and block

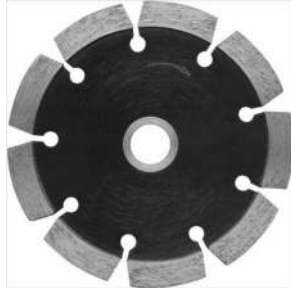

Item #	Size
TA542774593	4 1/2" x .250 x 7/8 - 5/8 B

HUSQVARNA

Super Premium Diamond Blades

MI5 General Purpose Dry/Wet Cutting

MI Series

- The MI5 blade fast cuts a wide variety of materials on the first pass, such as brick and some block
- This all-purpose diamond blade is the only one with aggressive notched segments which grab and grind material for a rapid first cut



Item #	Size
TA542774809	14" x .125 x 1" DP
TA542774817	20" x .140 x 1" DP

HUSQVARNA

Premium Diamond Blades

Dry/Wet Cutting

EH Series

- EH5 is a general purpose blade used for cutting concrete, masonry and stone
- EH8 blade will cut a wide range of abrasive materials such as soft brick, abrasive block, and green concrete or cured concrete with soft aggregate



Item #	Desc.	Size
TA542775594	EH5	12" x .125 x 1" DP - 20mm B
TA542778735	EH5	14" x .125 x 1" DP - 20mm B
TA542775596	EH8	12" x .125 x 1" DP - 20mm B
TA542775597	EH8	14" x .125 x 1" DP - 20mm B

HUSQVARNA

Quality Diamond Blades

VH5 General Purpose Dry/Wet Cutting

VH Series

- General purpose blade for cutting cured concrete and brick



Item #	Size
TA542777987	14" x .118 x 1" DP - 20mm B

HUSQVARNA

Super Premium Diamond Blades

General Purpose Dry/Wet Cutting

Barracuda™

- The Barracuda™ blade is for cutting almost any masonry, tile, stone or hard concrete material
- It is a fast, smooth cutting blade



Item #	Size
TA542761427	4 1/2" x .085 x 7/8 - 20mm - 5/8 B
TA542761431	8" x .085 x DM - 7/8 - 5/8 B
TA542761433	10" x .100 x 7/8 - 5/8 B

HUSQVARNA

Super Premium Diamond Blades

General Purpose Dry/Wet Cutting

TSD-T Dri Disc®

- Use the TSD-T blade for fast, smooth cutting of a variety of materials, including stone, tile, brick, concrete and masonry
- Gives turbo performance at an affordable price



Item #	Size
TA542761416	4" x .080 x 7/8 - 20mm - 5/8 B
TA542761420	7" x .095 x DM - 7/8 - 5/8 B



HUSQVARNA
**Super Premium
Diamond Blades**

**MS Brick & Block Dry/Wet
Cutting
Banner Line®**



- Blue 1 BLM blade can be used to cut general purpose medium-hard to hard brick, stone and hard concrete block
- Red 1 BLM blade for general purpose cutting of brick and hard paving block (50% brick, 50% block), can also cut abrasive granite

Item #	Desc.	Size
TA542750666	Blue 1 BLM	20" x .125 x 1 DP
TA542750667	Red 1 BLM	14" x .110 x 1 DP

HUSQVARNA
**Super Premium
Diamond Blades**

**GH General Purpose Abrasive
GH Series**



- For fast cutting of asphalt, asphalt over concrete and some abrasive green concrete

Item #	Desc.	Size
TA580601	GH10	14" x .125 x 1 DP - 20mm B

HUSQVARNA
**Premium Diamond
Blade**

**Hard Materials Dry/Wet
Cutting
TXS-S Dri Disc®**



- Fast cut a wide variety of materials including concrete, brick, masonry and stone
- Designed for small to medium jobs

Item #	Size
TA542774902	7" x .090 x DM - 7/8 - 5/8 B

HUSQVARNA
**Diamond Grinding
Discs**

**GW Series
Dri Disc®**



- GW1 is for fast removal (single rim) on concrete, masonry, stone and similar materials
- The GW2 is for long life and smooth finish (double rim) on concrete, masonry, stone and similar materials
- GW Turbo is for a faster and smoother finish (segment turbo) on concrete, masonry, stone and similar materials

Item #	Rim	Size
TA580735	GW1 (single)	4" x 5/8 -11 THD
TA580736	GW2 (double)	4" x 5/8 -11 THD
TA580737	GW1 (single)	7" x 5/8 -11 THD
TA580738	GW2 (double)	7" x 5/8 -11 THD
TA580761	GW1 (single)	4" x 7/8 - 5/8 B
TA580762	GW2 (double)	4" x 7/8 - 5/8 B
TA580763	GW1 (single)	7" x 7/8 - 5/8 B
TA621679	Turbo	7" x 5/8 -11 THD
TA621715	Turbo	4" x 5/8 -11 THD

HUSQVARNA
**Premium Diamond
Blades**

**Hard Materials Dry/Wet
Cutting
TSD-S Dri Disc®**



- Fast cutting a wide variety of materials, including concrete, masonry, brick and stone

Item #	Size
TA542761412	7" x .095 x DM - 7/8 - 5/8 B
TA542761413	8" x .095 x DM - 7/8 - 5/8 B

HUSQVARNA
**Porcelain + High
Production Tile Blades**

**Wet Cutting
Superlok®**



- Makes fast, smooth, chip-free cuts
- Use this blade to cut porcelain tile, granite and other stone materials
- Thicker core specification provides straighter, chip-free cutting during high production sawing

Item #	Size
TA542761276	10" x .060 x 5/8



HUSQVARNA
**High Production Tile
Blades**

**General Purpose Wet Cutting
Superlok®**

- Make fast, smooth cuts in a wide variety of soft to hard ceramic tile, marble and porcelain



Item #	Size
TA542761268	7" x .060 x 5/8"
TA542761270	10" x .060 x 5/8"

HUSQVARNA
Diamond Core Bits DRI8

**General Purpose Wet/Dry Cutting
Dri Bits™**

- Designed for long life drilling in lightweight block or concrete block materials on hand drills or angle grinders
- Can also be used for long life drilling of brick on hand drills
- Specially designed barrel vents keep bits cool and provide fast removal of cuttings (mount bits directly onto standard 5/8"-11 grinder spindles)
- Drill faster than conventional carbide-tipped percussion bits for a smoother finish



Item #	Size (in.)
TA542750649	1
TA542750651	1½
TA542750653	2
TA542750655	2½
TA542750656	3
TA542750658	4
TA542750660	5

HUSQVARNA
**Super Premium
Diamond Blades**

**Multi-Application Dry/Wet
Cutting
Barracuda™**

- Fast, smooth cutting on almost any masonry, tile, stone or hard concrete material



Item #	Size
TA772180	12" x .125 x 1 DP - 20mm B
TA772182	14" x .125 x 1 DP - 20mm B

HUSQVARNA
**Premium Diamond
Blades**

**Wet Cutting
Vanguard® II**

- Cuts soft to medium aggregates with light steel reinforcing



Item #	Desc.	Size
TA773204	Blue 250V	14" x .110 x 1 DP

HUSQVARNA
**Super Premium
Diamond Blades**

**Wet Cutting
Banner Line®**

- Blue 200B blade is a general purpose blade used to cut soft to medium-hard aggregate with light steel reinforcing
- Blue 300B blade cuts soft to medium-soft aggregate and can also be used for cured joint widening
- Red 450B-R blade is used for cutting green concrete, asphalt over concrete or asphalt with hard aggregate. Undercut protection is standard on this blade
- Black 500B-R blade has an extra long life when cutting abrasive asphalt. Undercut protection is standard on this blade



Item #	Desc.	Size
TA773236	Blue 200B	14" x .110 x 1 DP
TA773238	Blue 300B	14" x .110 x 1 DP
TA773240	Red 450B-R	14" x .110 x 1 DP
TA773242	Black 500B-R	14" x .110 x 1 DP

HUSQVARNA
**OilGuard Premium 2-Stroke
Engine Oil**

OilGuard oil is a high-quality two-stroke oil developed specially for dusty environments. It is easily recognized by its yellow colour. The oil can be used in any premium two-stroke engine, to provide maximum performance and lubrication.



Item #
TA504-06-72-01



HUSQVARNA
Foam Filter Oil

- Helps to trap airborne dirt, dust and sand to optimize engine performance



Item #
TA505-51-03-02

HUSQVARNA
**Max Performance
Diamond Core Bits**

Wet Cutting

- B5500 Standard bit has the longest life and lowest cost per hole when drilling a wide range of critically hard materials with steel reinforcing; also for brick and block
- B5500 FC is for the fastest possible drilling on critically hard materials like concrete with heavy reinforcing; effective on granite, marble and other stone material



Item #	Size (in.)
--------	------------

B5500 Standard

TA542785150	2
TA542785152	2½
TA542785154	3
TA542785156	3½
TA542785157	4
TA542785160	5
TA542785162	6
TA542785165	8

B5500 FC

TA542785111	1
TA542785112	1¼
TA542785115	1½
TA542785118	2
TA542785120	2½
TA542785122	3
TA542785125	4
TA542785128	5
TA542785130	6



BUILDINGS AND MATTERS, LLC
Hole Covers

- The industry's only core cover with a water-tight seal that keeps water out of open holes during construction
- Unique Dome Profile Has Many Benefits: optimizes material usage, minimizes tripping hazards, distributes structural capacity evenly - regardless of the diameter, allows holes as small as 2 inches apart to be covered, uses post-consumer recycled polypropylene that can be recycled
- Fluorescent Yellow
- No tools needed, simply press fit into hole until underside of rim is flush with floor
- Temperature Range: -20° F to 120° F
- Loads: Safety Factor >4 for a 150 psf load, >2 for a 250 pound load at the center
- To remove pry up with screwdriver (or similar tool) using the two slots on the underside of rim
- Made In The USA



Item #	Size Dia. (in.)
--------	-----------------

HP-P002.0	2
HP-P002.5	2½
HP-P003.0	3
HP-P003.5	3½
HP-P004.0	4
HP-P004.5	4½
HP-P005.0	5
HP-P005.5	5½
HP-P006.0	6
HP-P007.0	7
HP-P008.0	8
HP-P009.0	9

**Quickly and easily
cover holes in decks.**

- Reusable
- No more plates or plywood
- Removes tripping hazard



JIFFY MIXER Mixers

- Jiffy Mixer is an all purpose, heavy duty, extremely efficient industrial/commercial mixer.
- It is designed to quickly and thoroughly mix dense and viscous substances in an open container.
- It is equally effective with liquids, dry materials, liquid and dry materials combined, or multiple component materials.
- Made of stainless steel 304, its patented construction and design is for mixing, not just stirring.
- The leading edge of the lower horizontal blade will scrape the bottom of the mixing container to bring all settled material particles into the mixing unit.
- Jiffy Mixers operate with both electric and air-driven chucked power tools
- Pools with 450-750 rpms give the best rate of thorough mixing.
- Applications: Adhesives, sealers, cement, coatings, mortar, stains, . . .



LM is for pint containers

HS is for 1-2 gallon containers

ES is for 2-5 gallon containers

PS-1 with a 20 1/2" shaft is for 5-10 gallon containers

PS-2 with a 40" shaft is for 10-50 gallon containers

HD is for 75-100 gallon containers

Item #	Shaft Length (in.)	Container Size	Top Diameter (in.)	Bottom Diameter (in.)	Depth of Head (in.)	Shaft Diameter (in.)
JMLM	10 1/4	pint	1 1/4	1 3/8	1/4	
JMHS-1	10 1/4	1-2 gal.	2 5/8	2 3/8	1/4	
JMHS-2	14 3/4	1-2 gal.	2 5/8	2 3/8	1/4	
JMHS-3	30	1-2 gal.	2 5/8	2 3/8	1/4	
JMES	20 1/2	2-5 gal.	3 1/4	3 3/4	3/8	
JMPS-1	20 1/2	5-10 gal.	4 5/8	5 1/8	5	1/2
JMPS-2	40	10-50 gal.	4 5/8	5 1/8	5	1/2
JMHD	40	75-100 gal.	8 1/2	9 3/4	10	3/4



MARSHALLTOWN TROWEL CO.

Rub Bricks

20-Grit

- Fluted silicon carbide stone
- Comfortable handle securely attached
- Ideal for dressing down and removing form marks from concrete



Item #	Size (in.)
MS841	8x3 1/2x1 1/2

MARSHALLTOWN TROWEL CO.

Wood Backed Concrete Brooms

Black Polypropylene Bristles

- Long wearing 2-3/4" black polypropylene bristles set solidly into a natural lacquered hardwood block
- Threaded hole accepts any standard broom handle
- Ideal for applying non-slip finish to newly finished concrete surfaces



Item #	EDI	Size (in.)
MS847	847	36



MARSHALLTOWN TROWEL CO.

Masonry Brushes

- Bristles made of white tampico fiber and are set in hardwood block



Item #	Size (in.)
MS829	6½x1¾

MARSHALLTOWN TROWEL CO.

Bucket Brush with Tampico Bristles

- Made of four rows of 3-1/2" long white tampico bristles
- 6" plastic handle with hang clip to hook on side of bucket



Item #	Size (in.)
MS521	6x1¾

MARSHALLTOWN TROWEL CO.

Short Handle Acid Brush

- Bristles made with Tampafil plastic set in high-tensile strength foam plastic block
- Recommended for use in acid solutions to clean mortar from bricks and concrete from wood or metal forms and tools



Item #	Size
MS6523	8" Handle

MARSHALLTOWN TROWEL CO.

Concrete Darby

Mahogany

- Made from straight grain mahogany
- Unique two-way tapered blade
- 3-1/2" wide by 3/4" thick at the heel



Item #	Length (in.)	Handle	Wt
MS150	28	Single Loop	1.65
MS152	36	Two Loop	
MS151	45	Three Loop	2.56

MARSHALLTOWN TROWEL CO.

Tapered Magnesium Darby



DuraSoft® Handle

- The same lightweight, durable extrusion as our magnesium floats
- Blade is tapered from 3" at the heel to 2" at the toe

Item #	Length (in.)
MS4615	30

MARSHALLTOWN TROWEL CO.

Blue Steel Edgers

Straight End

Marshalltown®



- Heavy gauge blue steel high carbon blade
- Used to produce a radius at the edge of a concrete slab to prevent the edge from chipping

Item #	Size (in.)	Radius (in.)	Lip (in.)
MS162B	6 x 6	¾	½
MS163B	6 x 6	½	⅝
MS166B	9 x 6	½	⅝
MS167B	9 x 6	¾	⅞

MARSHALLTOWN TROWEL CO.

Straight Ends Concrete Edger

DuraSoft® Handle

- Heavy gauge high carbon steel blade
- Used to produce a radius at the edge of a concrete slab to prevent the edge from chipping



Item #	Size (in.)	Radius (in.)	Lip (in.)
MS36D	6 x 3	¾	½

MARSHALLTOWN TROWEL CO.

Concrete Edger

Straight Ends

- Heavy gauge high carbon steel blade
- Used to produce a radius at the edge of a concrete slab to prevent the edge from chipping



Item #	Size (in.)	Radius (in.)	Lip (in.)
MS120D	8 x 6	¾	½



MARSHALLTOWN TROWEL CO.

Walking Concrete Edger



- Made of heavy gauge blue steel
- Slightly convex blade prevents gouging
- Use our #9 or #10 handle (sold separately)
- Used to produce a radius at the edge of a concrete slab to help prevent the edge from chipping off

Item #	Size (in.)	Radius (in.)	Lip (in.)
MS124B	9 x 6	3/8	1/2

MARSHALLTOWN TROWEL CO.

Magnesium Hand Floats



Beveled Ends

- Extruded from very hard, durable, lightweight magnesium
- Comfortable handle is positioned to give the tool perfect balance
- Magnesium floats produce a smoother finish than wood

Item #	Size (in.)	Handle	Wt
MS142	12 x 3 3/8	Wood	1.4
MS145D	16 x 3 3/8	DuraSoft®	1.65
MS145SH	16 x 3 3/8	Structural Foam	
MS146D	20 x 3 3/8	DuraSoft®	

MARSHALLTOWN TROWEL CO.

Magnesium Bull Float



Square End

- Made from the finest extruded magnesium available
- Lightweight, long wearing and properly balanced to provide the finish you want

Item #	Size (in.)
MSB42	42 x 8
MSB45	45 x 8
MSB48	48 x 8

MARSHALLTOWN TROWEL CO.

Rubber Floats



- 5/8" thick red rubber bonded to aluminum backing plate
- Used by plasterers & other finishers for textured finishes

Item #	Size (in.)
MS38	9 x 4 Fine

MARSHALLTOWN TROWEL CO.

Rubber Floats



Aluminum Backing Plate

- Molded black rubber pad is very comfortable and has a dense texture
- Float face is permanently cemented to the lightweight aluminum backing

Item #	Size (in.)
MS40	9 x 4

MARSHALLTOWN TROWEL CO.

Fine Plastic Foam Float



- Fine cell plastic foam pad specially bonded to an aluminum backing plate

Item #	Size (in.)
MS46G	9 1/2 x 4

MARSHALLTOWN TROWEL CO.

Magnesium Bull Float



Round End

- Made from the finest extruded magnesium available
- Lightweight, long wearing and properly balanced to provide the finish you want

Item #	Size (in.)
MSB48FR	48 x 8

MARSHALLTOWN TROWEL CO.

Blue Glider with Rounded Ends



- Made of blue spring steel
- A C-channel runs the length of the gliders to help strengthen the blade

Item #	Size (in.)
MSBG48	48 x 12 3/8

MARSHALLTOWN TROWEL CO.

Walking Groovers



Zinc Double End

- Made from high-quality, long wearing zinc
- Has the weight and finish to cut quickly and cleanly
- Double end bit permits use in either direction

Item #	Size (in.)	Radius (in.)	Bit (in.)
MS836	8 x 4 3/8	1/4	1 x 3/8



MARSHALLTOWN TROWEL CO.

Concrete Groover

Stainless Steel

- Blade made of stainless steel
- Properly shaped bit and leading edge cuts a sharp groove
- Bit Size: 1/4" radius, 1/2" width, 1/2" depth



Item #	Size (in.)
MS180D	6 x 3

MARSHALLTOWN TROWEL CO.

Drywall Hammer

16" Hickory Handle

- Wedge shaped steel blade is notched underneath and doubles as a nail puller
- Lightweight and perfectly balanced



Item #	Weight (oz.)
MS800	12

MARSHALLTOWN TROWEL CO.

Wood Handle

With Steel Clevis

Wood handles are fitted with a steel clevis

- For use with both fresno trowels and walking edgers
- Size: 6'
- Diameter: 1-1/2"



Item #
MS10

MARSHALLTOWN TROWEL CO.

QLT Powder Coated Blue Aluminum

Push Button Handle Section

- Constructed of thick-walled aluminum tubing
- Quick connect snap spring positively lock handles in place



Item #	Length (in.)	Dia (in.)
MS17-6ASU	72	1 3/4

MARSHALLTOWN TROWEL CO.

Wood Pole Sander Handle

- Made from hardwood
- Steel end cap for setting nails



Item #	Size (in.)
MS28L	60

MARSHALLTOWN TROWEL CO.

Curved Wood Trowel Handle

- Curved wood finishing trowel handle
- Will fit all of our Marshalltown finishing trowels



Item #
MS402

MARSHALLTOWN TROWEL CO.

Threaded Aluminum Handle Section

- The large threads can be combined with similar handles made by others



Item #	Length (in.)	Dia (in.)
MSB5-72	72	1 3/4

MARSHALLTOWN TROWEL CO.

Aluminum Hawk

- Made of heavy gauge, hard-rolled aluminum
- Lightweight but durable
- Edges have been smoothed and the corners rounded
- Has a threaded 3-5/8" flange
- Used for holding plaster during application

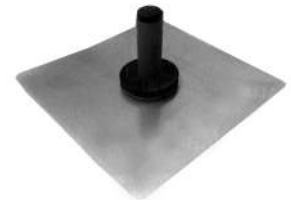

Item #	Size (in.)
MS1D	13 x 13

MARSHALLTOWN TROWEL CO.

Blue Steel Taping Knife

DuraSoft® II Handle

- Tapered blade for corner work
- One of the most lightweight knives on the market



Item #	Size (in.)
MS4510D	10 x 3
MS4512D	12 x 3



MARSHALLTOWN TROWEL CO.

Jiffler Mixer®

3-1/2" Wheels



- Plated steel wheels
- Wheels can be adjusted on the shaft
- Unique action mixes fast as the lower wheel cuts upward and upper wheel downward to create counter flow

Item #	Size (in.)	Shaft (in.)
MS893	3½	16

MARSHALLTOWN TROWEL CO.

Aluminum Concrete Placer



- Light aluminum mounting bracket that mounts over the blade
- Has new open blade design and is contoured for added strength

Item #	Size (in.)	Blade (in.)
MSAP738	54 x 1½	19½ x 4

MARSHALLTOWN TROWEL CO.

QLT All Aluminum Concrete Placer



- Aluminum construction, powder coated
- Braced for additional strength
- Soft grip end-cap

Item #	Size (in.)	Blade (in.)
MSAP753H	60	19½ x 4

MARSHALLTOWN TROWEL CO.

QLT Lightweight Aluminum Concrete Placer



- Strong, lightweight aluminum head
- Head is powder coated and braced for additional strength

Item #	Size (in.)	Blade (in.)
MSAP867H-5	54	19½ x 4

MARSHALLTOWN TROWEL CO.

Steel Spred-Kretes



- Blade is 12 ga. cold rolled steel
- Steel ferrule welded securely to blade holds contoured handle firmly in place
- Superior to a jam type connector
- Used for spreading, grading, and striking off concrete

Item #	Size (in.)
MS826	20 x 4
MS828	54 x 1¼

MARSHALLTOWN TROWEL CO.

Floor Scrapers



- 60" steel handle welded to angle iron bracket
- 1-1/8" diameter handle

Item #	Desc.	Size (in.)
MS820	Floor Scraper	20 x 4½
MS820B	Replacement Blade	20 x 4½

MARSHALLTOWN TROWEL CO.

Magnesium Alloy Screed



- Made from the finest magnesium alloy available, won't rust or rot
- End capped to prevent concrete from getting inside

Item #	Size (ft. x in. x in.)
MS822	12 x 2 x 4
MS825	16 x 2 x 4

MARSHALLTOWN TROWEL CO.

Big Diamond Concrete Tamper



- Reinforced splash-way grill
- Built to take the pounding and stay flat
- Properly balanced handle with rubber grips to ensure easy, safe handling

Item #	Size (in.)
MST34	34 x 7½



MARSHALLTOWN TROWEL CO.
Blue Steel Step Tool

- 90° blade angle
- Made of blue steel



Item #	Size (in.)	Radius (in.)	Type
MS174B	6 x 6 x 6	½	Cove (Inside)
MS175B	6 x 6 x 3	½	Nose (Outside)

MARSHALLTOWN TROWEL CO.
Finishing Trowels

High Carbon Steel

- Highest grade hardened and tempered spring steel blade, properly shaped
- Beveled work edges prevent surface aggregate popping



Item #	Size (in.)	Handle
MSMXS57D	14 x 3	DuraSoft®
MSMXS60D	16 x 3	DuraSoft®
MSMXS64D	14 x 4	DuraSoft®
MSMXS66D	16 x 4	DuraSoft®
MSMXS81D	18 x 4	DuraSoft®
MSMXS20D	20 x 4	DuraSoft®
MSMXS205	20 x 5	Hardwood

MARSHALLTOWN TROWEL CO.
Fully Rounded Finishing Trowel

High Carbon Steel

- Highest grade hardened and tempered spring steel blade, properly shaped
- Fully rounded ends prevent the blade from digging into the concrete



Item #	Size (in.)	Handle
MSMXS66RE	16 x 4	Curved Wood
MSMXS81FRD	18 x 4	DuraSoft®
MSMXS205FR	20 x 5	Curved Wood
MSMXS205RD	20 x 5	DuraSoft®

MARSHALLTOWN TROWEL CO.
Midget Trowels

Durasoft® Xtralite®

- Aluminum alloy Xtralite® mounting is lightweight but very strong
- Curved natural finish hardwood handle



Item #	Size (in.)
MS11	8 x 3

MARSHALLTOWN TROWEL CO.
Narrow London Brick Trowel

w/ DuraSoft® Handle

- Forged from a single piece of high grade tool steel
- Impact area is stronger
- Handle rise is set for the correct hang and balance
- Blade is taper ground and polished



Item #	Size (in.)
MS33 11FG	11 x 4¾

MARSHALLTOWN TROWEL CO.
Margin Trowel

- Forged from a single piece of high carbon steel
- Tempered, ground, and polished from toe to heel



Item #	Size (in.)	Handle
MS52D	5 x 2	DuraSoft®
MS54	5 x 1½	Hardwood

MARSHALLTOWN TROWEL CO.
Trowel & Square Ornamental Tool

- Perfectly forged and tempered
- Used in the detailing of ornate foam shapes and unusual wall surfaces
- Ideal for plaster work and dry-wall work in small areas



Item #	Size (in.)
MS13080	¾ x 8½
MS13081	½ x 9½
MS13082	⅝ x 10½
MS13083	¾ x 10½
MS13084	1 x 10½



MARSHALLTOWN TROWEL CO.

Notched Trowel

Plastic Handle

- Used to spread adhesive or mastic on the base surface before laying tile, carpet, or other floor coverings
- Dual notch patterns



Item #	Size (in.)
MS207	9 x 4

MARSHALLTOWN TROWEL CO.

Margin Trowel

- Tempered steel blade is fully ground and polished

Item #	Size (in.)	Handle
MS97	5 x 2	Hardwood



MARSHALLTOWN TROWEL CO.

Round End Fresno Trowel

- Round ends leave no drag marks
- For use with our #9 or #10 handle (sold separately)



Item #	Size (in.)
MSC24R	24 x 5
MSC30R	30 x 5
MSC36R	36 x 5
MSC48R	48 x 5



MULTIQUIP INC

Portable Concrete Mixer Electric Mix-N-Go

- The Mix-N-Go is durable, versatile and ideal for users of all skill levels
- Perfect for small footings, bases, patching
- Use as a wheelbarrow or with a stand
- Thick polyethylene drum - Resists rust and dents
- 3 cf of mixing capacity



Item #	Desc.
MQMC3-PE	3cf, .75 HP Electric 115V 1F, Includes stand

MULTIQUIP INC
**Walk Behind Power
Trowel**

- A 36-inch ring diameter
- Fully enclosed belt guard
- Access panel provides quick access to trowel arms and blades
- Optimal balance for smooth finishing



Item #	Desc.
MQJ36H55-QXH	4-blade, 36", Honda, 60-115 blade

MULTIQUIP INC
**Electric Vibrator
Motors**

- Large vibration isolated handles protect the motor and operator
- Flow-through ventilation reduces contamination by taking in air from the rear of the motor
- Quick disconnect knob for easy shaft removal



Item #	Amps	Volt/Freq	HP	RPM	Req. Shaft
MQCV1	10	120v 50/60 Hz	1	16,000	314V
MQCV2	15	120v 50/60 Hz	2	18,000	FS
MQCV3	20	120v 50/60 Hz	3	19,250	FS

MULTIQUIP INC
**Flexible Vibrator
Shafts**

314V-Series

- Requires BP25H, CV1 Drive Motors

Item #	Length (ft.)
MQ314V-7	7
MQ314V-10	10



MULTIQUIP INC
**Flexible Vibrator
Shafts**

FS-Series

- Requires BP25H, CV2, CV3, G55H Drive Motors

Item #	Length (ft.)
MQFS7	7
MQFS10	10
MQFS14	14





MULTIQUIP INC

4-Cycle Gasoline Rammers

Our 4-cycle rammers are available with the choice of Honda or Robin engines. The units have lower noise levels, reduced emissions and fuel requirements while increasing performance. No need for mixed fuel.



Item #	Desc.
MQMTX70	Honda GX100, 3350 lbs force 11.2" shoe

MULTIQUIP INC

Plate Compactors

Forward Plate Compactors

- Ideal for compaction of granular soils
- Water tanks on selected models for asphalt applications
- Honda engine



Item #	Centrifugal Force (lbs.)	Exciter Speed	Speed Min (Ft.)	HP	Plate Width (in.)	Weight (lbs.)
MQMVC82VHW	3080	5600	82	4.8	17.7	198

MULTIQUIP INC

Plate Compactors

Reversible Plate Compactors

- High-horsepower gasoline and diesel engines
- Selected models include extension plates as standard
- Hydraulic forward and reverse



Item #	Centrifugal Force (lbs.)	Exciter Speed	Speed Min (Ft.)	HP	Plate Width (in.)	Weight (lbs.)
MQMVH206GH	7860	5200	75	7.1	19.5	459

MULTIQUIP INC

Steel Vibrator Heads

- Round head radiates vibration in all directions
- Case hardened tip for extra durability
- Extra thick shell resists wear



Item #	Head Type	Dia (in.)	Length (in.)	Req. Shaft	Req. Drive Motor
MQ1400HD	Steel	1 $\frac{5}{8}$	15 $\frac{1}{4}$	FS	BP25H, CV2, CV3, G55H
MQ1700HD	Steel	1 $\frac{11}{16}$	15	FS	BP25H, CV2, CV3, G55H
MQ2100HD	Steel	2 $\frac{1}{8}$	13 $\frac{1}{4}$	FS	BP25H, CV2, CV3, G55H

OZTEC

OZTEC INDUSTRIES, INC. Steel Vibrator Heads



- Produce the highest amplitude and centrifugal force, generating the largest radius of influence available
- The benefits are superior consolidation, increased productivity, and a process that is more "forgiving" of less than perfect vibration technique
- High frequency-low amplitude for narrow, delicate forms or filling ICFs

Item #	Head Diameter (in.)	Radius of Action "R" (in.)	X = 1½ Times Radius of Action (in.)	Amplitude. Centerline to Side (in.)	Centrifugal Force (lbs.)	Compaction Rate (yds \dot{S} /hr)
OZH175OZ	1¾	9	14	0.08	1200	8 - 16

OZTEC INDUSTRIES, INC. Concrete Vibrators

Electric-Powered Drive Motors



- Lightweight, compact and with the included comfortable shoulder strap, become a one man power unit that will speed through the stiffest concrete
- Fully interchangeable and reversible flexible shafts (2 ft. to 21 ft. shafts can be coupled for longer lengths)
- Hooks for shoulder strap
- Larger rubber shock absorbers
- Full wrap around protective frame
- Standard with the Quick Disconnect "QD" system
- Changing shafts and heads on the job is a snap
- Units meet all United States OSHA Standards

Item #	Amps	HP	Max Head Steel (in.)	Max Head Rubber (in.)
OZ1.8OZ	15	1¾	None	
OZ2.4OZ	17	2¼	2	2¾ Short

OZTEC INDUSTRIES, INC. Flexible Vibrator Shafts



- Inner cores are made from extra-high carbon steel wires with casings made from tough abrasion resistant neoprene rubber, reinforced with multiple layers of high tensile wire braiding with a hardened flat steel liner
- Rigid enough for driving into the stiffest concrete without kinking yet limber and non-slip for easy and effective handling
- Interchangeable on all Oztec power units, are reversible (doubling their service life), and come supplied with "quick change" adapters

Item #	*Shaft Length (ft.)
OZFS10OZ	10
OZFS14OZ	14
OZFS21OZ	21

PRIMESOURCE

PRIMESOURCE Tie Wire

- Used for tying rebar or similar applications
- 16.5 gauge



Item #	Desc.
BCTW16	3½ lbs. Roll

PRIMESOURCE Merchant Wire

- Galvanized smooth coil wire
- 9 ga., 100 lb. coil



Item #
PRMSWG9100

JACKSON

JACKSON SAFETY Rebar Protector Caps BarGard®



- Constructed of heavy-duty polyethylene
- BarGard® helps prevent injury from exposed rebar, pipe, or rod ends that stick out
- Bright orange/lime green colored caps are easy to see and easy to use
- BarGard® can also be used to protect threaded bars, bolts, or pipe ends

Item #	Desc. (in.)
JS3005543	A-10 Fits rebars ¾ to 1¾ dia. and 1¾ ID pipe
JS3005545	A-20 Fits rebars 1 to 2¼ dia.
JS3005547	A-5 Fits rebars ¾ to ¾ dia. and 1 ID pipe



JACKSON SAFETY

Rebar Protector Caps

**CAL-OSHA
BarGard®**



- Fits rebar #3-7, 3/8" to 7/8" diameter
- Stands up to weather and temperature conditions
- Metal reinforced/safety orange color

Item #	Model
JS3011839	DISC-10



RAVEN INDUSTRIES

Underslab Vapor Retarder Seam Tape

VaporBlock™



- White single-sided tape combines a heavy-duty, weather-resistant polyethylene backing with an aggressive rubber adhesive
- Typical applications include vapor retarders, covers and liners

Item #	Size (ft.)
RNVAPOR BOND	4 x 210 roll

**Call Edge for
submittal
information.**

RAVEN INDUSTRIES

Underslab Vapor Retarder Boot Kit

VaporBlock™



- The VaporBoot System is designed to assist in securing pipe and other penetrations that run vertically through the vapor retarder material
- VaporBoots are produced from high performance VaporBlock™ material with a precut center marker

Item #	Size (in.)
RNVAPOR BOOT	18 x 18

RAVEN INDUSTRIES

Underslab Vapor Retarder/Barrier

VaporBlock™

- VaporBlock™ is a high performance underslab vapor retarder designed to retard moisture migration through concrete slabs-on-grade



Item #	Thickness (mil)	Size (ft.)	Classification	Tensile Strength (New Material) (lbs/in)	Tensile Strength (After Exposure) (lbs/in)	Puncture Resistance (g)	Max Use Temp (°F)	Min Use Temp (°F)	Permeance	UoM
RNVB10	10	15x200	Class A, B, & C	52	53	2,600	180	-70	.0146	RI
RNVB15	15	12x200	Class A, B, & C	88	82	4,000	180	-70	.009	RI



SONOTUBE®

Round Concrete Tube Forms

- Rain-resistant technology keeps wet weather from impacting your pour
- Easier to setup and brace so multiple columns can be poured at one time
- Superior strength-to-weight properties prevent blowouts



Item #	Dia. (in.)	Length (ft.)
SOT8-12	8	12
SOT10-12	10	12
SOT12-12	12	
SOT18-12	18	12
SOT24-12	24	12
SOT36-12	36	12
SOT48-12	48	12



INDUSTRIAL THERMO POLYMERS
Tundra Foam Backer Rod

Backing Material

- Ideal non-gassing backup material that is inserted into construction and pavement joints to control sealant depth
- Creates a backstop to facilitate accurate sealant tooling and configuration
- Permits proper sealant airing, yielding a quality bond breaker between the backup material and the sealant
- Suitable for expansion and contraction joints, window glazing, curtain wall joints, partitions, precast units and copings, parking decks, bridge construction, etc.
- Compatible both chemically and physically with virtually all known hot pour and cold applied sealants, including silicone and rubber asphalt



Item #	Size (in.)	Package (ft.)
IT78TUNDRA	7/8	1050
IT118TUNDRA	1 1/8	600
IT112TUNDRA	1 1/2	350

INDUSTRIAL THERMO POLYMERS

Standard Backer Rod

Backing Material

- Ideal compressible and non-absorbent backup material that is inserted into a joint to control sealant depth
- Creates a backstop to facilitate accurate sealant tooling and proper sealant wetting of the joint surfaces, yielding a quality bond breaker between the backup material and the sealant
- Can also be used as a temporary joint seal
- Suitable for glazing installations, window and door applications, expansion joints, curtain wall joints, partitions, log construction, pavement jobs, repairs, precast units and copings
- Compatible with butyl, polysulfide, acrylic polyurethane, silicone and most other cold applied sealant compositions



Item #	Size (in.)	Spool (ft.)
IT14	1/4	2000
IT38	3/8	2100
IT12	1/2	1250
IT58	5/8	775
IT34	3/4	1100
IT1	1	600
IT1-1/4	1 1/4	400
IT1-1/2	1 1/2	(66) 6 lengths
IT2	2	(38) 6 lengths



SURFACE SHIELDS
Builder Board

- 100% recyclable - at least 33% post consumer
- Heavy-duty, reusable temporary floor protection
- Less expensive and 1/3 the weight of 1/8" masonite
- Tough enough to be driven on - approx. 48 mil. thick



Item #	Desc.
SFBLD38100	38"x 100' Roll



PRIMESOURCE

Construction Stakes

- Durable steel makes it easier to drive in tough soil conditions
- No more mushroomed, splintered or cracked wooden stakes



Item #	Size (in.)	Desc.
RM3/4X18R	3/4x18	Round
RM3/4X24R	3/4x24	Round
RM3/4X30R	3/4x30	Round
RM3/4X36R	3/4x36	Round
RM3/4X48R	3/4x48	Round



CHAPIN MANUFACTURING INC

Sprayers

Lined Steel

Tri-Poxy®

- Tri-Poxy® lined steel for triple protection against corrosion, rust and damage from denting
- Brass fan spray nozzle for even coverage



Item #
CH1949

CHAPIN MANUFACTURING INC

Industrial Poly Heavy-Duty Sprayer

Acid- and Chemical-Resistant

- Usable Capacity: 3.0 gallons
- Hose Length: 36"
- Extension Tube: 18"
- Nozzle: Brass



Item #
CH2209

CHAPIN MANUFACTURING INC

Sprayers

Backpack

- SPR 4.0G/11.4L Chapin Poly Knapsack
- Internal 4 position spray valve for expert pressure control from 15 psi to 60 psi
- Padded carrying straps for fatigue-free operation



Item #
CH61800



JACKSON SAFETY

Barrier Fence

- Mono-oriented safety fencing with horizontal openings
- Size/Color: 4x100 Orange

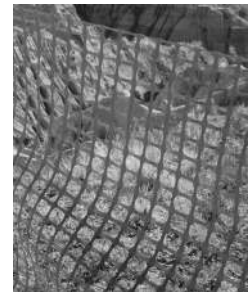

Item #
JS3007305

JACKSON SAFETY

Erosion Control Silt Fence

With Stakes

- Used for controlling dirt transfer and erosion
- Woven silt fence is made from UV stabilized, high density polyethylene (HDPE)
- Freezing point of approximately -112F makes this an excellent choice for cold conditions
- Fence design spaces stakes every 10'



Specifications:

- Fence Height: 3 ft.
- Fence Length: 100 ft.
- Fence Color: Black
- Stake Material: Hardwood stakes
- Stake Height: 42"

Item #	Color
JS3007594	Black



SONNEBORN
Maintenance of Concrete

Div.3 03 01 00
Concresive® Standard LVI

Concresive® Standard LVI is a two component moisture-insensitive 100% solids low-viscosity epoxy adhesive. It penetrates cracks and voids, bonding hardened concrete to hardened concrete. It can be mixed with aggregate to make high-strength, high-modulus epoxy concrete and mortars



- Rapid strength gain: Quickly returns repaired areas to service

Item #	Size
SO51335577	15.2 oz. biaxial cartridge
SO25013230	3 gal. unit

SONNEBORN
Maintenance of Concrete

Div.3 03 01 00
10-61 Rapid Mortar

10-61 Rapid Mortar is a one-component shrinkage-compensated cement-based mortar with an extended working time. It is designed for repairing horizontal concrete surfaces

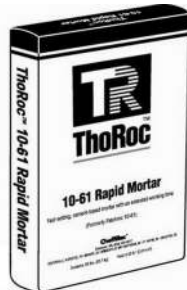

- Extended working time: Can be used for deep or large repairs; allows repairs at elevated temperatures
- Excellent resistance to freeze/thaw: Outstanding durability
- Nongypsum based: Volume stability
- Shrinkage compensated: Minimizes cracking from drying shrinkage; reduces stress at the bondline
- Can be extended up to 100% by weight with 3/8" (10 mm) aggregate: Economical applications
- Proprietary cement blend: Bonds to carbonated and noncarbonated concrete substrates

Item #	Size
SO55405340	50 lb. Bag

SONNEBORN
Maintenance of Concrete

Div.3 03 01 00
Concresive® Liquid LPL

Concresive® Liquid LPL is a two component 100% solids liquid epoxy bonding adhesive

- Yield:
- Smooth surfaces: 100 ft²/gallon
 - Rough surfaces: 50 – 75 ft²/gallon
 - Very long working time: Facilitates proper placement; ideal for warm environments
 - Moisture insensitive: Bonds to damp concrete surfaces



Item #	Size
SO25013138	3 gal.

SONNEBORN
Maintenance of Concrete

Div.3 03 01 00
Acryl 60®

Acryl 60® is an acrylic-polymer emulsion mixed with Portland cement mortars, plasters, stucco, and concrete mixes to enhance their physical properties, adhesion to substrates, and durability



- Acrylic polymer: Significantly improves adhesion, cohesion, tensile, compressive, and flexural strengths of cement-based materials
- Excellent chemical and UV resistance: Promotes long-lasting repairs
- Improved freeze/thaw stability of Portland-cement-based materials: Suitable for cold climate applications
- Stable: Will not re-emulsify when exposed to water

Item #	Size
SO1006489	1 Gal.
SO1006488	5 Gal.

SONNEBORN
Concrete Curing

Div.3 03 35 00
Lapidolith®

Lapidolith® is a magnesium-fluorosilicate concrete hardener and dust-proofer that bonds chemically with the concrete to strengthen and harden floors that are porous, readily absorptive, and only moderately hard.

Features:

- Concrete hardener
- 100% reactive with the free lime in concrete
- Tightly binds together the cement, sand, and aggregate particles
- Nonfilm forming
- Compatible with most resilient tile adhesives

Item #	Size (gal.)
SO02-506-5	5

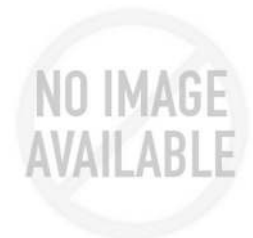



SONNEBORN
Concrete Curing

Div.3 03 35 00
Kure-N-Harden™



Kure-N-Harden™ is a water-soluble, inorganic, and silicate-based curing, hardening, sealing, and dust proofing compound. Use it for freshly placed and finished concrete and in renovation of aged concrete. It contains no VOC's.

Features:

- Protects floors during construction
- Easy application, quick drying
- Water based
- Aid for curing new concrete
- Concrete hardener
- Improved abrasion resistance

Application:

- Concrete floors and pavements
- Curing of fresh concrete
- Renovation of aged concrete
- Industrial, processing and brewing plants
- Educational, medical and nursing facilities
- Utility, public and multi-residential buildings

Location:

- Interior or exterior
- Below, at or above grade

Item #	Size (gal.)	Yield
SO01844-051	5	150 – 200 ft 2/gal Coverage may vary with application method, surface conditions, and porosity

SONNEBORN
Concrete Curing

Div.3 03 39 00
Kure 1315



Kure 1315 is a transparent water-based blend of acrylic polymers used to cure, seal and dustproof freshly placed and finished concrete floors. It contains no oils, saponifiable resins, waxes or chlorinated rubbers. It complies with ASTM C 1315, Type I, Class A

Item #	Size (gal.)	Yield
SO1005308	5	Ft2/gallon per coat (m2/L)

SONNEBORN
Concrete Curing

Div.3 03 39 00
Kure-N-Seal™



Kure-N-Seal™ is a transparent, sprayable, acrylic-based polymer solution that cures, seals, and dust-proofs freshly placed or aged concrete in a single operation. It complies with ASTM C 309.

Features:

- Ensures high curing efficiency
- Reduces surface absorption of concrete
- Cures, seals and dustproofs
- Retains the moisture in concrete
- VOC compliant
- Compatible with a variety of carpet and tile adhesives

Item #	Size (gal.)	Yield
SO11-495-5	5	Curing only: 200 – 400 ft2/gal-lon (4.9 – 9.8 m2/L)

SONNEBORN
Concrete Curing

Div.3 03 39 00
Kure-N-Seal™ WB

Kure-N-Seal™ WB is a waterborne, acrylic, 15% solids, and transparent curing, sealing, and dustproofing compound. Apply it on damp or dry surfaces of freshly placed and finished concrete, aged floors, and exposed aggregate.

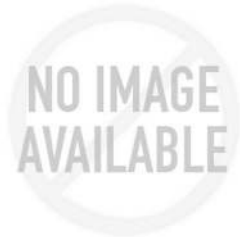

Item #	Size (gal.)	Yield
SO1005314	5	Ft2/gallon per coat (m2/L)

SONNEBORN
Concrete Curing

Div.3 03 39 00
Kure-N-Seal™ 30



Kure-N-Seal™ 30 is a transparent, 30% solids, solvent-based, acrylic curing membrane. Apply it to damp or dry surfaces to provide a high-gloss finish.

Item #	Size (gal.)	Yield
SO1005300	5	For curing only, 1 coat may be sufficient; 2 coats, however, will give best results. To seal and dustproof, 2 coats are required.



SONNEBORN
Concrete Curing

Div.3 03 39 00
Kure-N-Seal® 25 LV

Kure-N-Seal™ 25 LV is a transparent, low-viscosity, 25% solids, VOC-compliant, solvent-based acrylic curing, sealing and dustproofing compound designed for better application at cool temperatures. Its semi-gloss finish provides good UV resistance and gloss retention



- Curing compound: Efficiently retains moisture for freshly placed concrete; ensures proper strength development; minimizes shrinkage cracking
- Low viscosity: Provides better application at cool temperatures
- Sealer and dustproof: Makes surfaces easier to clean and maintain
- Semi-gloss appearance: Surfaces look newer and brighter
- Abrasion resistant: Withstands foot traffic; provides extended wear
- Compatible with a variety of adhesives: Can be tiled or carpeted over
- 25% solids by weight: Economical, VOC compliant

Item #	Size
SO51678592	5 gal. pail
SO51378645	55 gal. drum

SONNEBORN
Concrete Curing

Div.3 03 39 00
Kure-N-Seal® W

Kure-N-Seal™ W is a transparent, acrylic, 20% solids, and water-based curing, sealing, and dustproofing compound. Use it on both freshly placed and finished concrete and aged concrete floors



- Curing compound: Efficiently retains moisture for freshly placed concrete; ensures proper strength development; minimizes shrinkage, cracking

Item #	Size
SO51679069	5 gal. pail
SO51679016	55 gal. drum

SONNEBORN
Concrete Curing

Div.3 03 39 00
Sonosil®

Sonosil® is a clear water-soluble, sodium-silicate-based hardening and dustproofing compound. It is easy to apply, leaves no residue, dries quickly, and is available with fugitive red dye for even application



- Residue free: Compatible with most resilient floor-covering adhesives

Item #	Size
SO51707265	5 gal. pail
SO51707212	55 gal. drum

SONNEBORN
Concrete Curing

Div.3 03 39 00
Kure 200W

- Kure 200W is a water-based polymer and wax-emulsion curing and sealing compound. It helps concrete surfaces obtain maximum strength and greater wear resistance. When applied at 300-400ft²/gallon (7.44-9.8 m²/L), it meets the moisture retention requirements of ASTM C 309, Type 1, specification for liquid membrane-forming curing compounds
- Ensures high curing efficiency: Allows concrete to attain full strength potential



Item #	Size
SOKURE200W-5	5 gal. pail
SOKURE200W-55	55 gal. pail

SONNEBORN
Concrete Curing

Div.3 03 39 00
Acryseal HS

Acryseal HS is a clear 100% acrylic solvent-based concrete sealing compound. It can be used to cure and seal freshly placed concrete or Sonoshield® Decorative Coatings. It meets EPA VOC regulations



- Retains moisture for freshly placed concrete: Ensures proper strength development

Item #	Size
SO51656862	5 gal. pail



SONNEBORN
Concrete Curing

Div.3 03 39 00
Konductokure®



Konductokure® is made of hard resinous wax suspended in a resinous conductive membrane. It allows the floor to develop maximum potential strength while keeping moisture sealed during the curing period. After curing, Konductokure® need not be removed but can be polished to a wax-like finish

- Effectively cures concrete: Reduces shrinkage cracking

Item #	Size
SOKONDUCTOKURE	5 gal. pail

SONNEBORN
Non-Metallic Non-Shrink Grout

Div.3 03 62 13
Masterflow® 928



Masterflow® 928 grout is a hydraulic cement-based mineral-aggregate grout with an extended working time. It is ideally suited for grouting machines or plates requiring precision load-bearing support

Yield:

One 55 lb bag mixed with approximately 1.26 gallons of water, yields approximately 0.50 ft³ of grout

- Extended working time: Ensures sufficient time for placement
- Can be mixed at a wide range of consistencies: Ensures proper placement under a variety of conditions
- Freeze/thaw resistant: Suitable for exterior applications
- Hardens free of bleeding, segregation, or settlement shrinkage: Provides a maximum effective bearing area for optimum load transfer
- Contains high-quality, well-graded quartz aggregate: Provides optimum strength and workability
- Sulfate resistant: For marine, wastewater, and other sulfate-containing environments

Item #	Size
SO51681772	55 lb. Bag

SONNEBORN
Metallic Non-Shrink Grouting

Div.3 03 62 16
Embeco® 885



Embeco® 885 is a cement-based metallic-aggregate grout with an extended working time. It is ideally suited for grouting machines or plates requiring optimum toughness and precision load-bearing support, including machine bases subject to thermal movement. Embeco® 885 grout meets the requirements of ASTM C 1107 and the U.S. Army Corp of Engineers CRD C 621, Grades B and C

Item #	Size
SO51670854	55 lb. bag

SONNEBORN
Epoxy Grouting

Div.3 03 63 00
Masterflow® 648 CP



Masterflow® 648 CP is a high-performance epoxy grouting material for support of heavy equipment. It ensures the proper transmission of static and dynamic loads to the equipment foundation

Item #	Size
SO648CPKIT	230 lb. unit

SONNEBORN
Epoxy Grouting

Div.3 03 63 00
Masterflow® 648 CP Plus



Masterflow® 648 CP Plus grout is a three-component modified epoxy-resinbased grout with variable fill rates.

Masterflow® 648 CP Plus combines high-temperature performance and crack resistance with outstanding flow characteristics

Item #	Size
SO25013038	216 lb. unit



SONNEBORN
Epoxy Grouting

Div.3 03 63 00

Masterflow® 668B Chock Grout

Masterflow® 668B Chock Grout is a three-component modified epoxy-resin-based grout. It is used where high-performance properties are required in less-accessible spaces subject to thermal shock and high vibrations. It can be placed from 1/2 – 3" (12.5 – 76 mm) thick on a base-grout pour, directly to the concrete or steel to steel



Item #	Size
SO668BCHOCK	60.6 lb. unit

SONNEBORN
Epoxy Grouting

Div.3 03 63 00

Masterflow® MP

Masterflow® MP grout is a three component epoxy grout. It is used for anchoring bolts and rebar, for baseplate support, and for general repair of concrete structures and surfaces



- High early and 7-day strengths: Rapid return of equipment to service

Item #	Size
SO25013586	2 ft.Š unit

SONNEBORN
Industrial Sealers

Div.3 03 40 00

Cast-Off®

Cast-Off® is a solvent-based, VOC compliant, non staining form-release agent.



Features:

- Water-resistant chemical barrier
- No residue transfer
- Compatible with conventional mix designs
- Alkali resistant
- Safe for wood fibers
- VOC compliant
- Reduced rust on steel forms and equipment
- Placement up to 5 weeks before concrete

Item #	Size (gal.)	Yield
SO17-160-5	5	

SONNEBORN
Industrial Underlayment

Div.7 07 10 00

Sonoshield® DBS 6200

DBS 6200 constitute a series of polypropylene drain board systems that significantly reduce the amount of water coming into contact with the waterproofing membranes, relieve hydrostatic pressure, and extend the life of the waterproofing system. DBS 6200 incorporates a plastic sheet adhered to the back surface of the drain core, offering a protective layer that prevents die cutting of the waterproofing membrane.



Item #	Size	Yield
SO1020553	4x50 ft roll	200 ft ² (18 m ²) per 4 by 50 ft. (1.2 by 15.2 m) roll

SONNEBORN
Industrial Dampproofing

Div.7 07 11 00

Hydrocide® 600, 700

Hydrocide® 600, 700 are cold-applied water-based emulsified-asphalt damp-proofing and vapor-retarding coatings for use on "green" or slightly damp surfaces. Hydrocide® 600 is fiber-free for application by brush or spray.



Hydrocide® 700 is reinforced with long fibers for application by trowel.

Item #	Size (gal.)
SO1001729	5
SO26-435-5	5



SONNEBORN
Dampproofing

Div.7 07 11 00

Mastics

Sonoshield® Mastics are cold-applied solvent-based dampproofing and vapor-retarding coatings for use on dry, cured surfaces

Mastic contains long fibers for trowel application

Semi-Mastic contains short fibers for brush or spray application

128 Spray Mastic contains selected fibers for spray application (or trowel at low temperature)

648 Mastic is fiber-free for application by brush or spray



Item #	Size
SOMASTIC-5	5 gal. pail
SOMASTIC-50	50 lbs.
SOMASTIC-55	55 gal. drum
SOMASTIC-548	548 lbs.
SOSEMI-MASTIC-5	5 gal. pail
SOSEMI-MASTIC-42	42 lbs.
SOSEMI-MASTIC-55	55 gal. drum
SOSEMI-MASTIC-460	460 lbs.
SO648MASTIC-5	5 gal. pail
SO648MASTIC-42	42 lbs.
SO648MASTIC-55	55 gal. drum
SO648MASTIC-460	460 lbs.
SO128SPRAYMASTIC-55	55 gal. drum
SO128SPRAYMASTIC-534	534 lbs.

SONNEBORN
Industrial Sealants

Div.7 07 14 00

Sonoshield® HLM 5000®

HLM 5000® is a one-component, moisture-curing, bitumen-modified polyurethane elastomeric waterproofing membrane for exterior below-grade or between-slab applications. HLM 5000® comes in a variety of grades for different applications: HLM 5000® SL (self-leveling) is formulated for application by squeegee to horizontal areas. HLM 5000® S (spray) is a specially formulated version of 5000T for spray application. HLM 5000® R (roller) is formulated for application by roller to vertical and some horizontal surfaces.



Item #	Size (gal.)	Type
SO30-484-5	5	Roller
SO30-485-051	5	Self Level
SO30-486-5	5	Spray

SONNEBORN
Cementitious Waterproofing

Div.7 07 16 00

THoroseal®

Thoroseal® is a Portland-cementbased coating for concrete and masonry that resists both positive and negative hydrostatic pressure.

Polymer-modified with Acryl 60®,

Thoroseal® creates a low-maintenance and highly durable waterproof barrier

- Waterproof: Protects building interiors from dampness and moisture damage



Item #	Size
SOThoroseal-10	10 lb.
SOThoroseal-30	30 lb.
SOThoroseal-50	50 lb.
SOThoroseal-60	60 lb.

SONNEBORN
Cementitious Waterproofing

Div.7 07 16 00

Thoroseal® 550i

Thoroseal® 550i is a ready-to-use polymer-modified cement-based coating. It is used to waterproof and protect concrete, mortar, and masonry surfaces requiring either positive- or negative-side waterproofing. Thoroseal® 550i can be applied by low-pressure spraying or hand troweling



Item #	Size
SO51719667	55 lb. bag

SONNEBORN
Cementitious Waterproofing

Div.7 07 16 00

Flextight™

Flextight™ is an acrylic-modified, Portland cement-based flexible waterproofing membrane for concrete and masonry. Use it above or below grade on interior or exterior surfaces



Item #	Size
SO57474990	5 Gal. pails kit



SONNEBORN
**Cementitious
Waterproofing**

Div.7 07 16 00
Tegraproof®

Tegraproof® is a crystalline capillary waterproofing coating for concrete. It is designed for coating applications both above and below grade

- Withstands positive and negative hydrostatic pressure, Dual-sided waterproofing
- Resists de-icing salts: Suitable for winter environments



Item #	Size	Color
SO51710498	55 lb. pail	Gray
SO51710551	55 lb. pail	White

SONNEBORN
**Cementitious
Waterproofing**

Div.7 07 16 10

Thorseal® Foundation Coating

thorseal® Foundation Coating is a water-proof Portland-cement-based coating for below-grade exterior concrete and masonry surfaces. Polymer-modified with Acryl 60®, Thorseal® Foundation Coating creates a cost-effective durable waterproofing barrier



Item #	Size
SO51719773	50 lb. bag
SO51719826	60 lb. pail

SONNEBORN
Industrial Sealers

Div.7 07 19 16

Hydrozo® Silane 40 VOC

Hydrozo® Silane 40 VOC is a clear, breathable, solvent-based, VOC-compliant, greater than 40% alkylalkoxysilane penetrating sealer. It penetrates deeply and chemically reacts with concrete to form a long-lasting water-repellent surface.



Item #	Size (gal.)	Yield
SO1007072	5	Poured in place and precast concrete: 125 – 225 ft ² /gallon

SONNEBORN
Water Repellents

Div.7 07 19 16

Hydrozo® 100 Plus

Hydrozo® 100 Plus is a clear, breathable, high-performance, clear, 100% silane sealer with an oliophobic additive for protecting new and existing concrete surfaces. It penetrates deeply, sealing out water, chloride ions, and acids—reducing staining caused by motor oils, grease, and food



Item #	Size
SO51677744	5 gal. pail
SO51677691	55 gal. drum

SONNEBORN
Industrial Sealant

Div.7 07 92 00

SL 1™

SL 1™ is a one-component nonpriming, self-leveling elastomeric polyurethane designed for expansion joints in concrete floors and decks. Use it where flexibility as well as abrasion and puncture resistance are required.



Item #	Size (oz.)	Color	Pack
SO35-913-1/10	11	Limestone	30
SO35-913	30	Limestone	12

SONNEBORN
Industrial Sealants

Div.7 07 92 00

Primer 733

Primer 733 is a quick-drying solvent-based primer for priming joints and substrates before application of Sonolastic® NP 1™, TX 1, NP 2™, Ultra, SL 1™, SL 2™, and Sonolastic® 150 series sealants.



Item #	Size (pints)	Pack
SO46-733	1	12



SONNEBORN
Joint Sealants

Div.7 07 92 00
Sonolastic® TX 1



TX 1 is a one-component, texturized, moisture-curing, gun-grade polyurethane sealant. It requires no mixing and typically requires no priming on common building materials. TX 1 has a textured appearance, which blends well with masonry substrates.

- One component: Requires no mixing; saves on labor
- Gun grade: Does not sag in vertical joints
- Weather resistant: Produces long-lasting weather-tight seals
- Accepts joint movement of $\pm 25\%$: Keeps moving joints tight
- High-quality polyurethane polymer: Resists age hardening

Item #	Color	Size
SO55395429	ALU GRY	10.14 oz. tube
SO55395482	BLK	10.14 oz. tube
SO55395535	BUF	10.14 oz. tube
SO55395588	IVR	10.14 oz. tube
SO55395641	MED BRZ	10.14 oz. tube
SO55395694	NAT STN	10.14 oz. tube
SO51721310	NAT STN	20 oz. sausage
SO55395747	OFF WHT	10.14 oz. tube
SO55395853	SPE BRZ	10.14 oz. tube
SO55395906	STN	10.14 oz. tube
SO51721363	STN	20 oz. sausage
SO55395959	WHT	10.14 oz. tube

SONNEBORN
Joint Sealants

Div.7 07 92 00
Sonolac®



Sonolac® is a siliconized acrylic-latex gun-grade caulk for use in general purpose exterior and interior applications

Yield:

Approximate yield for 1/4 by 1/4" joints: 24.4 lineal ft per cartridge

- Siliconized: Provides optimum adhesion
- One component: Easy to apply; saves labor
- Nonstaining, nonbleeding: Maintains original appearance
- Dry on surface within 30 minutes: Readily paintable; speeds job-site production
- Water based: Easy to clean up with water
- Lasting flexibility: Provides a durable seal

Item #	Size	Color
SO45-471	10.14 oz. tube	White

SONNEBORN
Joint Sealants

Div.7 07 92 00
SONOLASTIC® NP 2™



NP 2™ is a three-component, highly flexible, nonpriming, high-performance polyurethane sealant. It has been successfully tested for joint movement of plus or minus 50%. Choose from 40 popular stock colors and 470 standard colors

- Elastomeric, movement capability of $\pm 50\%$: Adds protection against unanticipated movement
- Resistant to weather, airborne pollutants, and chemicals: Long-lasting performance on all applications
- Superior adhesion: Requires no primer on many construction materials
- NP 2™ accelerator available: Use for cold climate applications; speeds initial cure
- Sonneborn® Color Portfolio available: Choose from 463 custom colors
- Excellent gunability over a broad temperature range: Speeds application
- Nonstaining: Use where aesthetics are a primary concern
- UL listed: Passes 4 hour, 4 inch, fire and hose stream test when used with Ultra Block® or mineral
- Suitable for water immersion: Documented performance in wet areas

Item #	Size
SO53354453	1½ gal. unit
SO50150022	3 gal. unit

SONNEBORN
Joint Sealants

Div.7 07 92 00
Sonolastic® SL 2™



SL 2™ is a multi-component, self-leveling, elastomeric polyurethane sealant that is mixed and poured in place. When cured, it forms a tough, resilient joint seal that resists penetration, abrasion, and remains flexible when exposed to weather and aging

- Movement capability $\pm 25\%$: Expands and contracts with joint movement
- Abrasion resistant: Handles pedestrian and vehicular traffic
- Penetration resistant: Withstands pressure from pointed objects
- Resilient: Resists permanent deformation
- Resistant to weathering and aging: Provides long-lasting durability
- Service range from -40 to 180° F (-40 to 82° C): Suitable for all climates
- Available in custom colors: Can be color matched to any substrate
- Self-leveling and slope grades: Provides application versatility
- Suitable for water immersion: Documented performance in wet areas

Item #	Size
SO55403273	1[1/2] gal. unit
SO55403379	3 gal. unit



SONNEBORN
Joint Sealants

Div.7 07 92 00
Expansion Joint Filler



Sonolastic® Expansion-Joint Filler is a lightweight, resilient, superior-grade polyethylene closed-cell backing for use in expansion joints in traffic-bearing substrates. It has extremely low moisture absorption and readily accepts joint movement

- Lightweight and economical: Less expensive than conventional joint fillers
- Closed-cell polyethylene: Extremely low moisture absorption; helps keep moisture from reaching the back side of joint sealants
- Resilient: Readily accepts joint movement
- Non-impregnated, non-staining, and non-bleeding: Will not discolor sealants or architectural substrates
- Inert: Compatible with cold-applied sealants
- Easy to cut: Not sticky in summer or brittle in winter
- No bondbreaker required: Sealants will not adhere to Expansion-Joint Filler
- Available in a variety of sizes: Provides better performance in all joint sizes
- Ease of installation and peel-off top: Significant cast and time savings

Item #	Size	Cuts	Pkg Qty
SOEJF1440	¼"x4'x100'	none	400ft.δ/bag
SOEJF1454	¼"x5'x100'	4"	500 ft.δ/bag
SOEJF1456	¼"x5'x100'	6"	500 ft.δ/bag
SOEJF14568	¼"x56"x100'	8"	467 ft.δ/bag
SOEJF3840	⅜"x4'x50'	none	200 ft.δ/bag
SOEJF3854	⅜"x5'x50'	4"	250 ft.δ/bag
SOEJF3856	⅜"x5'x50'	6"	250 ft.δ/bag
SOEJF38568	⅜"x56"x50'	8"	233.5 ft.δ/bag
SOEJF1240	½"x4'x50'	none	200 ft.δ/bag
SOEJF1254	½"x5'x50'	4"	250 ft.δ/bag
SOEJF1256	½"x5'x50'	6"	250 ft.δ/bag
SOEJF12568	½"x56"x50'	8"	233.5 ft.δ/bag
SOEJF3440	¾"x4'x9'	none	540 ft.δ/bag
SOEJF144	1"x4'x9'	4"	360 ft.δ/bag

SONNEBORN
Industrial Sealants
Reducer 990

- Used primarily to thin first coats on cementitious floors
- Cleans up tools and equipment

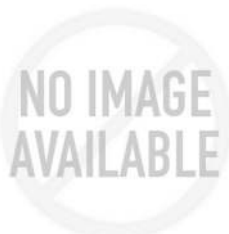

Item #	Size (gal.)	Yield
SO50-990-1	1	

SONNEBORN
Industrial Sealant

Div.7 07 92 00
Sonolastic® NP 1™



NP 1™ is a one-component, high-performance, nonpriming, gun-grade, elastomeric polyurethane sealant. It requires no mixing and typically requires no priming to bond to many materials, including concrete and masonry.

Features:

- Ready to use
- Joint movement capability ±35%
- Easy to gun and tool
- No primer required for most construction materials
- Weather resistantPackaging
- Wide temperature-application range
- Compatible with nonrigid coatings
- Superior holding power
- UL listed
- Suitable for water immersion
- Low VOC content

Application: Expansion joints, Curtain wall construction, Panel walls, Precast units, Aluminum and wood window frames, Roofing, Fascia, Parapets, Structural components, Vinyl siding, Wastewater treatment plants, Dams, Spillways and storm drains, Wetwells and manholes

Item #	Size	Color	Pack
SO32-957	10.1 oz cartridge	Special Bronze	30
SO32-957PP	20 oz sausage	Special Bronze	20
SO32-961	10.1 oz cartridge	White	30
SO32-961PP	20 oz sausage	White	20
SO32-962	10.1 oz cartridge	Off White	30
SO32-963	10.1 oz cartridge	Limestone	30
SO32-963PP	20 oz sausage	Limestone	20
SO32-964	10.1 oz cartridge	Stone	30
SO32-964PP	20 oz sausage	Stone	20
SO32-965	10.1 oz cartridge	Tan	30
SO32-965PP	20 oz sausage	Tan	20
SO32-966	10.1 oz cartridge	Black	30
SO32-966PP	20 oz sausage	Black	20
SO32-967	10.1 oz cartridge	Aluminum Gray	30
SO32-967PP	20 oz sausage	Aluminum Gray	20
SO32-968	10.1 oz cartridge	Medium Bronze	30
SO32-968PP	20 oz sausage	Medium Bronze	20
SO32-969	10.1 oz cartridge	Redwood Tan	30
SO32-970	10.1 oz cartridge	Hunter Green	30
SO32-971	10.1 oz cartridge	Anodized Aluminum	30



SONNEBORN
Joint Sealants
Div.7 07 92 00
Sonolastic® 150



Sonolastic® 150 with VLM Technology is a premium, very low-modulus, high-movement, nonsag, fast-curing, ready to-use, silyl-terminated polyether sealant. It combines the best qualities of organic and silicone sealants to keep moving joints weathertight

- Superior Adhesion: Long term Bond – reduced call backs
- Very low modulus: Accommodates extreme joint movement (100% extension in EIFS joints with little stress on bond line)
- Compatible with nonrigid coatings: May be painted soon after installation
- Easy to gun and tool: Speeds application; makes neater joints
- Ready-to-use 1 component: Reduces labor; speeds application
- Wide temperature application range: Use in all climates
- Weather resistant: Provides long-lasting weathertight seals
- Fast curing: Speeds jobsite production
- Nonstaining: Use safely on stone and other sensitive substrates
- Mildew resistant: Does not support mildew growth; offers low-odor alternative for sanitary areas
- Available in ProPaks: Reduces jobsite waste; lowers disposal costs
- Very low VOC's (2 g/L): Meets all State and Federal regulations

Item #	Color	Size
SO51703714	Aluminum Gray	10.14 oz.
SO51703820	Black	10.14 oz.
SO51704032	Limestone	10.14 oz.
SO51704138	Medium Bronze	10.14 oz.
SO51704244	Off White	10.14 oz.
SO51704350	Redwood Tan	10.14 oz.
SO51704562	Slate	10.14 oz.
SO51704668	Special Bronze	10.14 oz.
SO51704774	Stone	10.14 oz.
SO51704880	Tan	10.14 oz.



VINYLEX
Waterstop
PVC Compound

Vinylex Waterstop is a specially formulated polyvinyl chloride (PVC) compound manufactured from virgin materials as is evidenced by its natural color that fulfills all properties desirable for a waterstop. The material is tough, flexible, resilient, chemically inert, is not affected by weathering, low temperatures, or constant immersion in water. It will withstand rough treatment during installation, yet is relatively easy to install and splice.

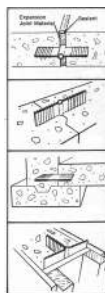

Item #
VXD6316



TARGET
Portland Expanding Grout



- TARGET® Portland Expanding Non-Shrink Grout consists of accurately weighed Portland cement, non-metallic aggregate, expanding agents and admixtures
- These materials are pre-blended, and require only mixing with water before use.
- In normal working temperature ranges of 10°C to 30°C (50°F to 86°F), the grout has a slight expansion prior to final set and is designed for use at dry pack, plastic, flowable or fluid consistencies.
- It also contains other admixtures to give non-shrink properties after final set has occurred to meet the requirements of ASTM 1107, Grade C, and US Corps of Engineers Specification CRD-C621.
- The grout contains no chlorides or other admixtures, which could aggravate corrosion of reinforcing steel or prestressing steel cables.
- 25 kg (55 lb) 56 bags/pallet
- On request, this product can be manufactured using Type V (Type 50) Portland cement for applications requiring improved sulphate resistance.
- Approximate water requirements are:
 - Dry Pack= 0.86 to 0.92 US gal/55 lb bag
 - Plastic= 1.36 US gal/55 lb bag
 - Flowable= 1.49 US gal/55 lb bag
 - Fluid= 1.65 US gal/55 lb bag
- Comprehensive Strength (psi) at 24 hrs with mix consistency of fluid: 1,410
- Comprehensive Strength (psi) at 3 days with mix consistency of fluid: 3,650
- Comprehensive Strength (psi) at 7 days with mix consistency of fluid: 5,280
- Comprehensive Strength (psi) at 28 days with mix consistency of fluid: 7,080
- Comprehensive Strength (psi) at 24 hrs with mix consistency of flowable: 2,460
- Comprehensive Strength (psi) at 3 days with mix consistency of flowable: 4,160
- Comprehensive Strength (psi) at 7 days with mix consistency of flowable: 6,020
- Comprehensive Strength (psi) at 28 days with mix consistency of flowable: 7,820
- Comprehensive Strength (psi) at 24 hrs with mix consistency of plastic: 3,190
- Comprehensive Strength (psi) at 3 days with mix consistency of plastic: 6,960
- Comprehensive Strength (psi) at 7 days with mix consistency of plastic: 7,580
- Comprehensive Strength (psi) at 28 days with mix consistency of plastic: 8,770
- Comprehensive Strength (psi) at 24 hrs with mix consistency of dry-pack: 6,680
- Comprehensive Strength (psi) at 3 days with mix consistency of dry-pack: 10,570
- Comprehensive Strength (psi) at 7 days with mix consistency of dry-pack: 11,510
- Comprehensive Strength (psi) at 28 days with mix consistency of dry-pack: 13,200

Item #
TG9991110



PACIFIC LASER SYSTEMS

Laser Plumb & Square

PLS3

- Accurate to within 1/4" at 100'
- Plumb instantly from floor to ceiling up to 50' off the ground
- Self leveling within +/- 6°
- Operating time: 30+ hours continuous
- Power supply: 3 AA batteries

Includes:

- PLS3 laser, wall bracket, carrying pouch, and floor stand



Item #

PACPLS3

PACIFIC LASER SYSTEMS

Horizontal-Vertical Layout Laser

PLS180

- Accurate to within 1/8" at 30'
- Self-leveling within +/-6deg
- Range 100'
- Pulsed beams for exterior applications (PLS-SLD detector required - sold separately)

Specifications:

- Power supply: 3 AA batteries
- Operating Time: 30+ hours
- 180 Degree Fan Angle
- Includes: PLS180 laser, wall bracket, carrying case & pouch



Item #

PACPLS180TOOL

PACIFIC LASER SYSTEMS

Horizontal-Vertical Layout Laser with Detector

PLS180 System

- Accurate to within 1/8" at 30'
- Self-leveling within +/-6deg
- Range 100'
- Pulsed beams for exterior applications (use PLS-SLD detector)

Specifications:

- Power supply: 3 AA batteries
- Operating Time: 30+ hours
- 180 Degree Fan Angle
- Includes: PLS180 laser, PLS-SLD detector, wall bracket, carrying case & pouch



Item #

PACPLS180SYSTEM

PACIFIC LASER SYSTEMS

360° Interior/Exterior Laser Level with Detector

PLS360 System

- Accurate to within 1/8" at 100'
- Self-leveling within +/- 6deg
- Provides 360deg horizontal reference plane
- Working Range 200'
- Can be used outdoors with the PLS SLD detector
- Operating Time: 35+ hours
- Power supply: 3 D batteries
- Includes: PLS360 laser, PLS-SLD detector, carrying case, & wall bracket



Item #

PACPLS360ESYSTEM

PACIFIC LASER SYSTEMS

360° Interior/Exterior Laser Level

PLS360

- Accurate to within 1/8" at 100'
- Self-leveling within +/- 6deg
- Provides 360deg horizontal reference plane
- Working Range 200'
- Can be used outdoors with the PLS SLD detector (sold separately)
- Operating Time: 35+ hours
- Power supply: 3 D batteries
- Includes: PLS360 laser, carrying case, & wall bracket



Item #

PACPLS360ETOOL

PACIFIC LASER SYSTEMS

Laser Plumb, Level & Square

PLS5

- Accurate to within 1/8" at 100'
- Self-leveling within +/- 8deg
- Pulsed beam for exterior layout with detector (detector sold separately)
- Power Source: 3 AA Batteries
- Operating time: 30+ hours continuous
- Includes: PLS5 laser, wall bracket, pouch, floor base, layout target & carrying case



Item #

PACPLS5TOOL



PACIFIC LASER SYSTEMS
Laser Plumb, Level & Square with Detector

PLS5 System

- Accurate to within 1/8" at 100'
- Self-leveling within +/- 8deg
- Pulsed beam for exterior layout with receiver (receiver sold separately)
- Power Source: 3 AA Batteries
- Operating time: 30+ hours continuous
- Includes: PLS5 laser, PLS-HVD detector, wall bracket, pouch, floor base, layout target & carrying case



Item #

PACPLS5SYSTEM

PACIFIC LASER SYSTEMS
90° Laser w/Detector and Tripod

PLS90KIT

- Accurate to within 1/8" at 100'
- Self leveling within +/- 6deg
- Clear lines on floor with a vertical fan angle; reference line up to 100'
- Working Range 250'
- Power supply: 3 AA batteries
- Operating Time: 30+ Hours continuous
- Includes: PLS90E laser, laser detector, carrying case, universal base, floor target & tripod



Item #

PACPLS90SKIT

PACIFIC LASER SYSTEMS
Long Range Rotary Laser System

HLE1000

- Accurate to within 3/32" at 100'
 - Self-leveling within +/- 5deg
 - Horizontal layout laser system for exterior applications
 - Working Range: 1000' radius
 - Power supply: 4 C batteries or NIMH battery
 - Class III laser; dual slope
- System Includes: HLE1000 laser, detector, remote control, 2 battery packs (NIMH & alkaline), NIMH battery charger, & carrying case



Item #

PACHLE1000

PACIFIC LASER SYSTEMS
360° Horizontal-Vertical Layout Laser

HVL100

- Accurate to within 1/8" at 60'
- Self-leveling within +/- 4deg
- 360deg horizontal and vertical lines
- Working range: 100'

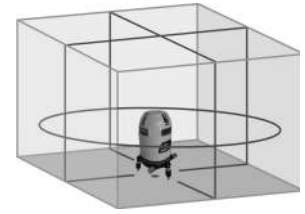

Includes: HVL100 laser, PLS-SLD detector, NIMH batteries & charger, wall bracket, adjustable turning base, layout targets & carrying case

Item #

PACHVL100

PACIFIC LASER SYSTEMS
Mid Range Rotary Laser System

Red or Green Laser

- Accurate to within 1/8" at 100'
- Self-leveling within +/- 5deg
- Horizontal and vertical operation
- Working Range: 500' radius
- Power supply: 4 C batteries or NIMH rechargeable battery
- Class II laser
- Available with green laser (ideal for mid-range interior layout) or red laser (for indoor/outdoor use)



System Includes: HVR505 laser, detector, remote control, NIMH battery & charger, ceiling bracket & carrying case

Item #

Laser Color

PACHVR505G Green

PACHVR505R Red

PACIFIC LASER SYSTEMS
Laser Layout Target

- For use with Pacific Laser Systems PLS-5 and PLS-5X

Item #

PACPLS10090



PACIFIC LASER SYSTEMS
Detector

PLS-SLD

- For use with the PLS180, PLS360, HVL100 & PLS90
- Used with PLS laser line tools to detect the line while outdoors or in bright conditions when you can't see the lines
- Maximum Working Range: 250'
- Power supply: (1) 9 Volt
- Includes: Laser Detector



Item #

PACPLSSLD



PACIFIC LASER SYSTEMS
Laser Plumb, Level & Square
PLS5XD



PLS HVD laser detector works with the ("new PLS5") or the old model PLS5X.

- Captures the pulsing points outdoors in bright sunshine when the points can no longer be seen by the human eye
- Allows the outdoor working range to be extended from around 80 feet (visible range to see the dot) to 250 feet (using the detector) in bright sunshine
- Makes an audible sound so that you know you've reached level

Item #
PACPLS-HVD

PACIFIC LASER SYSTEMS
Laser Stand



- Floor stand for use with PLS5 (laser sold separately)

Item #
PACPLS-10061

PACIFIC LASER SYSTEMS
Tripod

For Laser Levels

- Adjusts from 32" to 60" in height
- Mid weight aluminum construction
- Interior/Exterior rated
- For use with PLS laser units, primarily PLS90, PLS24X & PLSHVR
- 1/4 X 20 thread



Item #
PACPLS-20309

PACIFIC LASER SYSTEMS
Tripod

For Laser Levels

New PLS Elevator Tripod adjustable from 26-Inch to 114-Inch.

- Made for Interior work and works with all PLS Lasers
- Includes an adapter that converts the 5/8-11 large thread down to a 1/4-20 thread
- Perfect for tall ceilings up to 10-Feet with laser attached
- Includes leveling bullseye



Item #
PACPLS-20513



BLACK & DECKER
18V Cordless Rotary Laser Kit



Heavy-Duty DeWalt

Heavy-duty 18V Cordless rotary laser kit with digital laser detector and clamp

- Manual leveling system is accurate to $\pm 1/4"$ @ 100'
- Dual side-by-side laser diodes for an extremely bright, visible beam; digital laser detector (included) detects beam over long distances or in bright light conditions
- Protected rotary head & side impact roll cage for increased durability

Specifications:

- Power Supply: 9.6V - 18V DeWalt® Batteries
- Indoor Visibility Range (ft.): 200
- Range With Detector (ft.): 600

Includes:

- Rotary laser, 18V XR+™ battery, 1 hour charger, digital laser detector and clamp, laser target card, laser enhancement glasses and heavy-duty kit box

Item #
DTDW073KD

BLACK & DECKER
18V Cordless Rotary Laser Kit



Self-Leveling Int/Ext DeWalt

- Fully automatic horizontal and vertical self leveling with out-of-level shutoff eliminates user error, ensures accuracy, and reduces set-up time

- A manual single sloping mode allows the user to set grade $\pm 5^\circ$
- Wireless (IR) remote control operated scan mode creates a "laser chalkline" between two points for an extremely bright beam over long distances

- Digital laser detector extends interior and exterior range to 600'

Specifications:

- Power Supply: 9.6V-18V DeWalt® batteries
- Accuracy per 100 ft.: 1/8 in.
- Self-Leveling Range: $\pm 5^\circ$
- Indoor Visibility Range: 200 (dia) ft.
- Range with Detector: 2000 (dia) ft.

Includes:

- 1 hour charger, 18V XRP™ battery, digital laser detector, wall mount, wireless (IR) remote control, laser target card, laser enhancement glasses, kit box

Item #
DTDW079KD



STABILA
Electronic Levels

Tech Level
Type 196E



- With audible tone, level tells you plumb, level or any angle in-between
- Level reads in 5 different languages: Degrees, Percentage, mm/M-Millimeters per Meter, in./ft.- Decimal inches per foot, in./ft.- Fractional inches per foot

Item #	Length (in.)
SB37924	24
SB37948	48

STABILA

Extendable Plate Level



- Level is used for 9' and 10' ceiling construction
- Fully sealed solid rail (six sided) extension eliminates deflection, and delivers the smoothest extension movement available
- Top plumb vial is permanently positioned at eye level
- Frame side opposite the stand-offs is a level measuring surface and straight edge
- Vials are guaranteed for life never to fog, leak or require adjustment
- Certified accuracy in the top read position: 1/32" over 72"

Item #	Desc.
SB33610	6-10 ft.
SB33712	7-12 ft.

STABILA

Heavy-Duty Levels
Type 196



- Crystal clear vials readable in any direction with no change in accuracy tolerance
- Spring steel hairline indicators in vials
- Best frame strength-to-weight ratio
- Removable rubber end caps for scribing in corners and for reading tight header and sill openings

Item #	Lgth (in.)	Desc.
SB37416	16	W/one hand hole, 1 plumb vial
SB37424	24	W/hand hole
SB37448	48	W/hand hole
SB37459	59	W/hand hole
SB37472	72	W/hand hole
SB37478	78	W/hand hole
SB37524	59/24	Level Set w/hand holes
SB37532	78/32	amber Set w/hand holes
SB37496	96	W/no hand hole

STABILA
Magnetic Levels



Heavy-Duty
Type 96M

- Strongest Magnets, flush mounted - Work Hands-Free
- Spring steel hairline indicators inside the vials
- Certified Level Accuracy in top read position: 1/32" over 72"

Item #	Length (in.)	Desc.
SB38624	24	W/no hand holes
SB38632	32	W/no hand holes
SB38648	48	W/no hand holes
SB38678	78	W/no hand holes
SB38532	78/32	Jamber Set (78" has hand holes, 32" does not)

STABILA

Magnetic Torpedo Levels
Stabila® Type 81SM



- Certified level accuracy; in top read position: (1/32" over 72")
- Strongest magnets - work hands-free (#25100)
- Level accuracy guaranteed for life; vials will never fog, leak or require adjustment
- Length: 10"

Item #	Desc.
SB25100	81SM Magnetic
SB25245	45° Vial w/V-Groove
SB25360	360° Vial w/V-Groove



EMPIRE LEVEL
Steel Plumb Bob

- Steel plumb bob with plated finish to resist corrosion
- Ties easily to any string or line

Item #	Size (oz.)
EE908BR	8

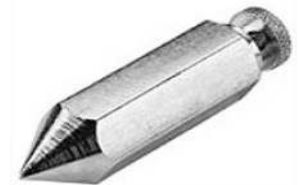

EMPIRE LEVEL

Brass Plumb Bob

- Solid brass plumb bob with lacquered finish to resist corrosion
- Ties easily to any string or line
- Extra hardened steel tip included

Item #	Size (oz.)
EE912BR	12
EE916BR	16
EE924BR	24





EMPIRE LEVEL
Magnetic I-Beam Level

581 Series

- Magnetic edge holds to ferrous surfaces
- Advanced frame design assures accuracy
- Top read window
- Beveled endcaps protect vials from shock



Item #	Length (in.)
EE581-24	24
EE581-48	48
EE581-72	72

EMPIRE LEVEL
Heavy-Duty I-Beam Level

e80 Series with True Blue®

- True Blue® vials are accurate to within 0.0005" per inch in all 10 level and plumb working positions
- Super strong anodized I-Beam frame
- Shock-absorbing endcaps
- Top reading window



Item #	Length (in.)
EEE80.24	24
EEE80.48	48
EEE80.72	72

EMPIRE LEVEL
Magnetic Box Level

em71 Series with True Blue®

- True Blue® vials are accurate to within 0.0005" per inch in all 10 level and plumb working positions
- Dual molded rubber endcaps for extreme shock resistance
- 300° view top-reading level vial
- Rare Earth magnets for super-strong hold onto ferrous surfaces
- Vial Guard to protect vials



Item #	Length (in.)
EEEM71.24	24
EEEM71.48	48

EMPIRE LEVEL
Masonry Level

**e90 Series with True Blue®
Magnum™**

- True Blue® vials are accurate to within 0.0005" per inch in all 10 level and plumb working positions
- Aluminum reinforced frame will not warp
- Polycarbonate lenses will not fog over
- Replaceable vials and lenses



Item #	Length (in.)
EEE90.24	24
EEE90.48	48

EMPIRE LEVEL
Magnetic Torpedo Level

EM81-Series with True Blue®

- True Blue® vials are accurate to within 0.0005" per inch in all 10 level and plumb working position
- Heavy-duty aluminum frame with top read window
- Strong-holding magnetic edge--EM81.10 with rare earth magnets
- V-grooved working edge fits on pipe or conduit



Item #	Length (in.)
EEEM81.10	10
EEEM81.9	9

EMPIRE LEVEL
Magnetic Protractor
Polycast®

- Magnetic base and back
- Easy reading dial with adjustable angle pointer
- Built-in angle pitch calculator on back
- Durable Polycast™ construction
- Transfer angles to within 1°



Item #
EE36

EMPIRE LEVEL
Professional Combination Square

Heavy-Duty with True Blue™

- Precision machined head and True Blue® vials ensure squareness to .001
- 12" etched stainless steel blade with inch graduations
- Heavy-duty machined square head
- Self-aligning drawbolt, hardened scriber



Item #	Length (in.)
EEE250	12



EMPIRE LEVEL
Pocket Combination Square

True Blue®

- Precision machined head and True Blue® vials ensure squareness to .001
- 6" etched stainless steel blade with inch graduations
- Machined square head
- Self-aligning drawbolt, hardened scriber



Item #	Length (in.)
EEE255	6

EMPIRE LEVEL
Try-Square
Polysteel™

- Stainless steel blade prevents rust and corrosion
- Polycast® handle includes acrylic vial for level, plumb and 90°/45° work
- 1/8" graduations reads full 8" on inside and outside measurements



Item #
EE120

EMPIRE LEVEL
Professional Framing Square

Anodized Aluminum

- 24" x 2" body, 16" x 1-1/2" tongue, 1/8" thick
- Easy-reading black anodized finish with permanently stamped white numbers
- Complete rafter tables and graduations
- Complete 1/8" graduated scale

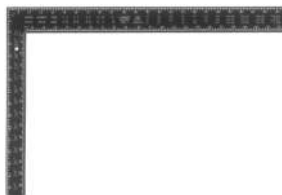

Item #
EE1190

EMPIRE LEVEL
Professional Framing Square

Aluminum "Fat Boy"

- 24" x 2" body, 16" x 1-1/2" tongue
- 50% thicker, heavy-gauge aluminum 3/16" thick resists bending
- Deep stamped inch graduations, numbers and rafter tables for long life
- Includes 1/8", 1/10", 1/12", 1/16" stamped graduations



Item #
EE1240

EMPIRE LEVEL
Drywall T-Square

- Durable yellow finish
- Large, bold numbers and graduations
- 1/8" thick, 47-7/8" long blade



Item #
EE410-48

EMPIRE LEVEL
Professional Drywall T-Square

- Anodized aluminum finish
- Large, bold numbers and graduations
- Patented rivet design. Permanently fixed joint of blade and head
- 3/16" thick, 53-7/8" long blade



Item #
EE418-54



CHECKPOINT LASER
Laser Level Cases

- Fits 2" - 6" tradesman type tool belts and is constructed of black, double layered ballistic nylon with laminated high density foam
- "Quick Clip" steel plated clip system for belt

Item #	Desc.
PDP397	Quick Clip Ballistic Case

CHECKPOINT LASER
Square Laser Level Kit

- The 880 square provides a unique machine quality squaring system that stows into the compact 880 square body
- Uniquely works as both a "flush" or "offset" square system



Item #
PDP302

CHECKPOINT LASER
Laser Torpedo Level

UltraMag G3

- Built-in auto 45-degree angle at one point for quick referencing and perfect alignment
- 4-vial system including 90, 45, 30 and oversized zero degree for easy viewing from oversized view ports
- 4 oversized rare earth magnets



Item #	Desc.	Frame Color
PDP300B	4 Vial Ultra Mag	Blue
PDP300R	4 Vial Ultra Mag	Red



CHECKPOINT LASER

Professional Torpedo Laser Level

880 G3



- Features a Class 3A more powerful laser and newly enhanced ergonomic design with a threaded front aperture which allows use of Checkpoint's specialized lenses and other accessories
- High powered laser beam system is accurate 1/4" (.250) at 100' and is 3-dimensionally aligned from all planes of reference

Item #

PDP327



STANLEY INDUSTRIAL TOOLS

Torpedo Level

9" Aluminum Die Cast Body
Contractor Grade



- Powerful magnet in base - holds level fast to all iron and steel surfaces
- Top reading
- Three 360° vials - plumb, level, and 45° are easily replaceable on the job

Item # Length (in.)

ST42-465 9

STANLEY INDUSTRIAL TOOLS

Steel Carpenter Square



- Body 24"x2", tongue 16"x1-1/2"
- Graduations 1/8" on face and back

Item #

ST45-500

STANLEY INDUSTRIAL TOOLS

Combination Square

12" Grooved Blade
Die Cast Metal Body



- Grooved blade, scratch awl, and hand regulated level vial included

Item #

ST46-222

STANLEY INDUSTRIAL TOOLS

Layout Tool

Aluminum Quick Square®

- Aluminum construction for durability
- 10-1/4" base length
- 6-3/4" rule length



Item #

ST46-067

STANLEY INDUSTRIAL TOOLS

Layout Tool

Aluminum Quick Square®

- Aluminum construction for durability
- Multipurpose tool is ideal for use as a 0° to 90° protractor scale
- 10-1/4" base length
- 6-3/4" rule length



Item #

ST46-071



KESON INDUSTRIES

Fiberglass Measuring Tapes



Open-Type Reel, Ultra-Glass Blade

Item #	Length (ft.)	Units
KSOTR1810100	100	ft., in., [1/8] & ft., [1/10], [1/100]
KSOTR1810200	200	ft., in., [1/8] & ft., [1/10], [1/100]
KSOTR1810300	300	ft., in., [1/8] & ft., [1/10], [1/100]

KESON INDUSTRIES

Metal Professional Measuring Wheels

- Only two moving parts (reset and ticker)
- 5-digit counter, up to 99,999 feet
- Compact fold-down handle
- Metal frame

Item #	Units	Dia. (in.)	Cir. (ft.)
KSMP401	ft.	15½	4
KSMP301	ft.	11½	3





KESON INDUSTRIES
**Indoor/Short Run Measuring
Wheels**
RoadRunner®



- Typically used in short run and indoor applications
- Easy to measure curved, horizontal and asymmetrical surfaces
- The single wheel and dual wheel both have a 5-digit, easy-read, magnified counter that measures 9,999 feet
- KSRR182 features dual wheels

Item #	Units	Dia. (in.)	Cir. (ft.)
KSRR112	ft., in.	4	1
KSRR182	ft., in.	4	1

KESON INDUSTRIES
Long Distance Measuring Wheels
RoadRunner®



- Telescoping handle
- 5-digit, easy-read, magnified counter measures 9,999 feet, 11 inches without resetting
- Metal/Resin composite wheel

Item #	Units	Dia. (in.)	Cir. (ft.)
KSRR30	ft., in.	12½	3



STANLEY INDUSTRIAL TOOLS
Tape Measure
Max®



- Mylar polyester film extends life of entire blade
- Easy to read, high contrast blade with 16" and 19.2" stud markings

Item #	Size (in. x ft.)
ST33-692	¾x16

STANLEY INDUSTRIAL TOOLS
3/8" Tape Measure

Stainless Steel Blade
Fatmax™



Item #	Length (ft.)
ST34-129	50
ST34-130	100

STANLEY INDUSTRIAL TOOLS
Measuring Tape
FatMax™



- 1-1/4" wide blade (25% wider) for more durability, easier to read graphics, stronger, stiffer blade during use
- 11' of blade stand out
- Heavy-duty Mylar "blanket-wrap" coating extends blade life up to ten times longer

Item #	Length (ft.)
ST33-716	16
ST33-725	25
ST33-730	30
ST33-735	35
ST33-740D	40

STANLEY INDUSTRIAL TOOLS
Tape Measure
3/4" Wide Blade
Powerlock®



- Powerlock® feature gives positive blade lock with no creeping
- 16 & 19.2 stud markings

Item #	Lgth. (ft.)
ST33-312	12

STANLEY INDUSTRIAL TOOLS
Tape Measure
8 m/26 foot x 1"



- 7' standout
- High-contrast blade for easy readability

Item #
ST30-456

STANLEY INDUSTRIAL TOOLS
Tape Measure
1" Blade
Max®



- BladeArmor™ coating maximizes durability of the hook end
- AirLock™ slide lock is easier to engage and adds protection against impact
- 8' Stand-Out

Item #	Length (ft.)
ST33-799	25
ST33-800	30

STANLEY INDUSTRIAL TOOLS
Leverlock Tape Measure
25 Ft. x 1" Wide Blade



- Unique power-return feature with automatic bottom lock, streamlines tape operation

Item #
ST30-825

STANLEY

STANLEY INDUSTRIAL TOOLS

Tape Measure

Powerlock®

- BladeArmor™ coating on the first 6" maximizes durability of hook end
- 16" and 19.2" stud center markings
- 8' tape standout



Item #	Length (ft.)
ST33-525	25

STANLEY INDUSTRIAL TOOLS

Tape Rule

Dupont Polyester Film

Powerlock®

- 7' standout
- 16" and 19.2" stud center markings simplify framing jobs
- Secure blade lock won't creep during measurements



Item #	Size (in. x ft.)
ST33-835	1 x 35

STANLEY INDUSTRIAL TOOLS

Steel Long Tape

3/8" Wide Blade

- Sturdy, lightweight molded case designed to fit the hand
- Easy-to-read white blade with 1/8" graduations; foot markings printed in red



Item #	Lgth. (ft.)
ST34-106	100

STANLEY INDUSTRIAL TOOLS

Chalk Box

FatMax® Extreme™

- Rewinds 5x faster – has a 5:1 gear ratio



Item #	Length (ft.)
ST47-480	100

APEX TOOL GROUP

COOPER HAND TOOLS

Power Return Tapes

Orange and Yellow Cases

Lufkin®

- Hi-Viz® case - easy to find on the job
- Case designed to fit perfectly in the hand
- Lightweight, high-strength case
- Toggle lock is positioned for convenient operations and holds the blade securely in any position



Item #	Blade Size (Wdth. (In.))	Blade Size (Lgth. (Ft.))
CGHV1049CME	1 (25 mm)	30 (9 m)
CGHV1425D	1	25 Engineer's
CGHV1048CM	25 mm	8 m

COOPER HAND TOOLS

Measuring Tape

Autolock 700 Series

Lufkin®

- Automatic blade lock holds the blade in extended
- Recessed lock release to reduce chance of accidental retraction
- Durable clear coat blade protection for longer blade life
- Blade Width: 1 in.
- Blade Length: 25 ft.



Item #
CGAL725

COOPER HAND TOOLS

Measuring Tape

Autolock 700 Series

Lufkin®

- Automatic blade lock holds the blade in extended
- Recessed lock release to reduce chance of accidental retraction
- Powerful dual magnets can also serve as a pick-up tool
- Blade Width: 1 in.; Blade Length: 25 ft.



Item #
CGAL725MAG

COOPER HAND TOOLS

Tape Measure

Hi-Viz® Orange

Lufkin®

- Lightweight, high-strength, contour grip case fits hand comfortably
- Hi-Viz® orange color makes tape easier to locate



Item #	Size (in. x ft.)
CGL525	1x25



COOPER HAND TOOLS
Tape Measure
Series HV1000 HiVis Orange
Lufkin®



- Case designed to fit perfectly in the hand
- Lightweight, high-strength case
- Quad Hook™, four rivets for extra strength (1" blade only)
- Engineer's tape is graduated feet, 1/10ths and 1/100ths on top edge and feet, inches and 16ths on bottom edge

Item #	Size (in.x ft.)
Engineers	
CGHV1312D	¾x12
Standard	
CGHV1425	1x25

COOPER HAND TOOLS
Engineer's Fiberglass Tape
10th 100ths
Hi-Viz® Orange



- Two-material grip is comfortable to use
- Hi-Viz® orange case is easy to find on the job site
- Open four-arm frame design protects blade
- Engineer's blade - 10ths and 100ths of feet plus feet
- Blade Width: 1/2"

Item #	Length (ft.)
CGFE100D	100

COOPER HAND TOOLS
Fiberglass Tape
Lufkin®



- Two-material grip is comfortable to use
- Hi-Viz® orange case is easy to find on the job site
- Open four-arm frame design protects blade, does not trap dirt in case
- Feet & inches graduated to 8ths; numbered ft. & instantaneous ft.
- Blade Width x Length: 1/2" x 100'

Item #
CGFE100

COOPER HAND TOOLS
Fiberglass Tape
Pro Series
Lufkin®



- 3-to-1 rewind for fast blade retraction
- 3/4" blade is more durable; large numbers are easy to read
- 2-sided blade, feet and inches on top, feet to 10ths and 100ths on bottom

Item #	Blade Lgth. (ft.)
CGPSFE100	100
CGPSFE200	200
CGPSFE300	300

COOPER HAND TOOLS
Surveying Tape

Lufkin® Chrome Clad®



- Blade Finish: Chrome Clad®
- Instantaneous reading
- Blade is 3/8" (10 mm) wide and .008" thick; Blade Length: 100 ft.

Item #
CGC1286

COOPER HAND TOOLS
Surveying Tape

Lufkin® Ny-Clad®



- Durable nylon coating on blade resists wear under extreme conditions
- Super fast 3-to-1 blade retraction saves time in the field
- Steel blade will not stretch under normal use
- Blade Width: 1/2"; Blade Length: 100 ft.

Item #
CGPS1806

COOPER HAND TOOLS
Surveying Tape

Lufkin® Hi-Viz® Atlas® Ny-Clad®



- Durable nylon coating on blade resists wear under extreme conditions
- Super fast 3-to-1 blade retraction saves time
- Steel blade will not stretch under normal use
- Blade Width: 1/2"; Blade Length: 200 ft.

Item #
CGPS1808

COOPER HAND TOOLS
Engineer's Folding Rule

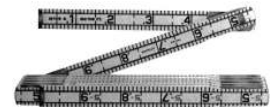

5/8" x 6'
Lufkin®

- 066D and 1066D graduated in feet, 10ths and 100ths feet
- Red foot figures

Item #
CG1066D

COOPER HAND TOOLS
Folding Rule

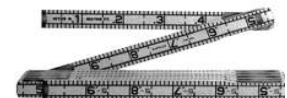

5/8" x 6'
Lufkin®

- Boxwood finish wood sections are 25% thicker than regular wood rules, withstands daily usage
- Bold red and black markings contrast sharply against white or natural finish background

Item #
CG066F

STARRETT®

Electronic Micrometer

734 Series

Full function electronic outside micrometers with a full range of features.



- Large, high-contrast LCD digital readout is easy to read and reduces errors
- Conventional inch or millimeter graduations standard
- No-glare black wrinkle finish on the frame
- Starrett no-glare satin chrome finish on thimble and sleeve
- Balanced frame design for comfortable and accurate measuring
- Ring-type knurled lock nut for quick and sure locking
- Smooth friction thimble for uniform pressure
- The anvil and spindle diameter is .250"
- Tapered frame for use in narrow slots and tight places
- Extremely hard and stable one-piece spindle
- Micro-lapped carbide measuring faces
- Includes one 3-volt battery for over one year's normal usage
- Automatic OFF after 30 minutes of nonuse
- Instant inch/millimeter conversion (except on 734 metric-only model)
- Measurement HOLD button
- Ability to zero tool at any position
- Ability to retain and return to the true zero reading of the micrometer
- PRESET button to install any reading at any position
- Ability to install minimum and maximum limits except on straight metric models

Item #	Range
STR3734XFL-1	0"-1"; 0-25mm

STARRETT®

Micrometers

216 Series

Mechanical digital micrometer



- The anvil and spindle are sized at .250"
- Clear, easily read numbers reduce errors
- No-glare black finish on the frame
- Starrett no-glare satin chrome finish on thimble and sleeve
- .001" or is read directly from the counter
- .0001" is read from the vernier scale on the micrometer sleeve
- Balanced frame design for comfortable and accurate measuring
- Ring-type knurled lock nut for quick and sure locking
- Gracefully designed tapered frame for use in narrow slots and tight places
- A choice of smooth friction thimble for uniform pressure on the 1-4" sizes or the combination ratchet and speeder for uniform pressure and quicker adjustment on all sizes
- Available in inch and millimeter models
- Available in .001", .0001" and .01 mm graduations

Item #	Range	Measuring Surfaces
STR216RL-1	0-1"	Steel
STR216XRL-1	0-1"	Carbide
STR216RL-2	1-2"	Steel

Item #	Range	Measuring Surfaces
STR216RL-3	2-3"	Steel
STR216RL-4	3-4"	Steel
STR216RL-5	4-5"	Steel
STR216RL-6	5-6"	Steel

STARRETT®

Micrometer Depth Gages

445 Series

The depths of holes, slots, shoulders and projections can be measured to .001" with these tools. A graduation of 0.001 mm is also available. Gages are furnished with choices of 3", 4" and 6" bases and have 5/32" diameter measuring rods



- Features a combination ratchet and speeder for uniform pressure and quicker adjustment
- Ring-type lock nut for quick and sure locking

Item #	Range	Base
STR445AZ-3RL	0-3"	3"
STR445AZ-6RL	0-6"	3"
STR445AZ-9RL	0-9"	3"
STR445AZ-12RL	0-12"	3"
STR445BZ-3RL	0-3"	4"
STR445BZ-6RL	0-6"	4"
STR445BZ-9RL	0-9"	4"
STR445BZ-12RL	0-12"	4"
STR445DZ-3RL	0-3"	6"
STR445DZ-6RL	0-6"	6"
STR445DZ-9RL	0-9"	6"
STR445DZ-12RL	0-12"	6"

STARRETT®

Offset Dial Caliper

120J Series

This tool has an adjustable jaw for versatility when measuring different planes that can't be reached with a regular caliper. The reference jaw is adjustable in height to be either longer or shorter than the sliding jaw.

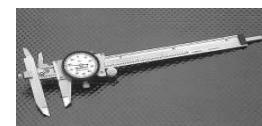

- Adjustable jaw-3-1/2" long
- Extends up to 5/8" longer than the sliding jaws

Item #	Range
STR120JZ-6	0-6"

STARRETT®

Dial Calipers With Long Nib Jaws

120B Series

This tool is a direct reading caliper with 3" long jaws, ideal for heavy duty use and for gaining access to more measuring area than with conventional calipers. Strong inside and outside nibs measuring from zero for outside measuring and from .300" for inside measuring

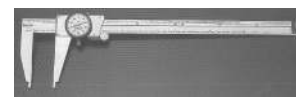

- Also available in 0-300 mm range

Item #	Range
STR120B-12	0-12"



STARRETT®
Electronic Calipers



799 Series

Light, comfortable, easy to use. They have a slim, streamlined profile, function buttons for zero and inch/mm, a large, clear, easy-to-read LCD display, and long battery life.

All Sizes:

- Inch/millimeter conversion reads .0005" or 0.01mm
- Easy access to single long-life battery
- Last measuring position retained when shut off
- Hardened stainless measuring surfaces for long life
- Fine adjustment thumb wheel
- Lock screw to hold the slide in position; zero at any position
- Resolution: .0005" (0.01mm)

6", 8" & 12" Calipers Only:

- Easy-to-read LCD, .32" high characters
- Auto shut-off after 5 minutes of nonuse
- Linear accuracy meets DIN862
- Integrated depth rod
- Jaw Depths: 6" Caliper - 1 1/2" outside, 5/8" inside; 8" Caliper - 2" outside, 5/8" inside; 12" Caliper - 2 1/2" outside, 23/32" inside

Extended Range 24" & 40" Calipers:

- Preset and hold feature
- Minimum and maximum limits set
- I.D. jaw dimension is .800"/20.32mm
- LCD characters are .50" high
- Auto shut-off after 30 minutes of nonuse

Item #	Range
STR799A-6/150	0"-6"
STR799A-8/200	0"-8"
STR799A-12/300	0"-12"
STR799AZ-24/600	0"-24"
STR799AZ-40/1000	0"-40"

STARRETT®
Telescoping Hole and Slot Gages

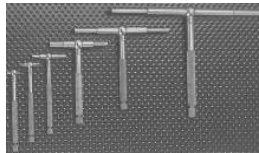

579 Series

Telescoping gages, self centering, with two telescoping arms. The handles are rigidly attached to the plungers and are automatically self-centering. Constant spring tension gives uniform contact pressure and both plungers are easily locked at any desired setting.

Item #	Range	Handle Length (in.)
STR579A	5/16"-1/2"	2 3/8
STR579A-8	5/16"-1/2"	8
STR579A-12	5/16"-1/2"	12
STR579B	1/2"-3/4"	2 3/8
STR579B-8	1/2"-3/4"	8
STR579B-12	1/2"-3/4"	12
STR579C	3/4"-1 1/4"	2 3/8
STR579C-8	3/4"-1 1/4"	8
STR579C-12	3/4"-1 1/4"	12
STR579D	1 1/4"-2 1/8"	2 3/8
STR579D-8	1 1/4"-2 1/8"	8
STR579D-12	1 1/4"-2 1/8"	12
STR579E	2 1/8"-3 1/2"	2 3/8
STR579E-8	2 1/8"-3 1/2"	8

Item #	Range	Handle Length (in.)
STR579E-12	2 1/8"-3 1/2"	12
STR579F	3 1/2"-6"	3 1/4
STR579F-8	3 1/2"-6"	8
STR579F-12	3 1/2"-6"	12

STARRETT®
Lock-Joint Transfer Type Calipers



36 Series Outside and 37 Series Inside

Starrett Lock-Joint Transfer Calipers have three key features... a transfer arm, fine-adjustment screw, and lock-joint. The transfer arm makes it possible to transfer measurements from the inside of chambered cavities, over flanges and other places where it is necessary to move the

legs after they have been set to size. The adjusting screw permits close adjustments for fine measurements. After the legs have been set to approximate size and the joint locked, the final adjustment is made by a few turns of the knurled adjusting nut.

- Legs are made from high-grade steel
- Sizes listed are the length of the legs. Their actual measuring capacity is about one-third greater than the size of the legs

Item #	Size (in.)
--------	------------

36 Series Outside Calipers

STR36-6	6
STR36-12	12
STR36-24	24

37 Series Inside Calipers

STR37-6	6
STR37-12	12
STR37-24	24

STARRETT®
Carpenters Dividers

92 Series



These dividers combine rigidity, light weight & easy handling. The sturdy construction of the joint, combined with the quadrant, eliminates side deflection of the legs. A quadrant adjusting nut permits fine-adjustments for close measurements. A check nut located between the legs locks the legs firmly after the proper adjustment has been made. This feature prevents the legs from moving in and out with the grain on wood when scribing, or sliding off rough spots when scribing on metals.

- Legs are forged steel, tempered & highly polished
- The adjustable point may be quickly removed & a common pencil inserted in its place
- The No. 92-9, 9" size is designed to accommodate a standard long pencil, especially useful for carpenters
- No. 88 Ball Points may be used with the No. 92 Series
- Actual capacity is one-third greater than the listed size

Item #	Size (in.)
--------	------------

STR92-6	6
STR92-9	9

STABILA

STABILA Laser Measure

Type LD300

- Length, area, volume & Pythagorean
- Continuous measure function



Item #	Accuracy	Range (radius) (ft.)
SB06300	± 1/16" over range	100

STABILA

STABILA Laser Measure

Type LD400

- Length, area, volume, continuous measure, square footage, Pythagorean, add and subtract
- Hooks edge points for inside corner/diagonal measurements
- Stores last 10 measurements



Item #	Accuracy	Range (radius) (ft.)
SB06400	± 1/16" over entire range	200

STABILA

STABILA Laser Measure

Type LD500

- Camera Target Locator with 4X Zoom
- Built in Inclinometer - built in, measures degrees, percent of grade and slope; stores last 20 measurements
- Integrated Calculator – readings can be added to, multiplied, subtracted from, etc.



Item #	Accuracy	Range (radius) (ft.)
SB06500	±1/16" over entire range	650

STANLEY

STANLEY INDUSTRIAL TOOLS

Stud Sensor

- Reads multiple depths (1/2", 1", 1-1/2") for versatility
- Unique "speaker" feature provides audible sound when locating studs
- High-visibility LED indicates precisely when stud edge is located



Item #
ST77-115

KRYLON
INDUSTRIAL

KRYLON® INDUSTRIAL PAINTS Inverted Marking Paint

Quik-Mark™

- High solids formation for bold, bright, visible markings
- Fast drying
- Penetrates & adheres to hot surfaces
- Convenient Spray Thru™ cap & non-clogging spray tip
- VCC Compliant, free of lead hazards



Item #	Color
--------	-------

Water Based Marking Paints

KRS03500	Clear
KRS03620	Caution Blue
KRS03901	Brilliant White
KRS03911	Brilliant Red

Fluorescent, Water Based

KRS03612	Pink
KRS03630	Safety Green
KRS03700	Orange

Solvent Based Marking Paint

KRS03600	Clear
KRS03611	A.P.W.A. Red
KRS03621	A.P.W.A. Blue
KRS03631	Green
KRS03821	High Visibility Yellow
KRS03900	Utility White

Flourescent, Solvent Based

KRS03613	Safety Red
KRS03614	Neon Green
KRS03622	Hot Pink
KRS03701	Red Orange
KRS03702	Orange

IRWIN
Industrial Tools

IRWIN INDUSTRIAL TOOLS

Chalk Line Reel

- Durable aluminum alloy construction
- Case doubles as plumb bob - plumb line
- Metal handle - self-locking on all reels
- Slide fill opening - Leak-proof
- Large grip anchor ring

Item #	Length (ft.)
IR64110	100





IRWIN INDUSTRIAL TOOLS
Chalk Line Reel

- 6X Faster than traditional chalk reels
- 6:1 Gear ratio
- Metal drive gear; metal handle
- Wide pronged hook
- Nylon/Polyester braided line



Item #
IR2031314DS

IRWIN INDUSTRIAL TOOLS
Chalk Reel Combo
Strait-Line™

- Length: 100'
- Chalk line reel and 4 oz. chalk refill



Item #	Desc.
IR64494	Speed-Line Chalk Reel with 4 oz. Blue Chalk
IR64495	Speed-Line Chalk Reel with 4 oz. Red Chalk

IRWIN INDUSTRIAL TOOLS
Refill Chalk

Plastic Squeeze Bottle
Strait-Line™

- Micro fine for more marking powder



Item #	Color
8 Ounce	
IR64901	Blue
IR64902	Red
IR64903	Yellow
IR64904	White
IR64905	Fl. Orange
IR64907	Fluorescent Green
IR64908	Black

IRWIN INDUSTRIAL TOOLS
Refill Chalk

Plastic Squeeze Bottle
Strait-Line™

- Permanent marking chalk; exterior use
- High visibility chalk for self chalking line reels; visible after weeks of weather exposure and jobsite wear
- For use on a variety of surfaces including wood, drywall, concrete, stone, and metal
- Weight: 5 lb.



Item #	Desc.
IR65101	Blue

Item #	Desc.
IR65102	Red
IR65103	Yellow
IR65104	White
IR65105	Fluorescent Orange
IR65108	Black

IRWIN INDUSTRIAL TOOLS
Replacement Line For
Chalk Line
Strait-Line®

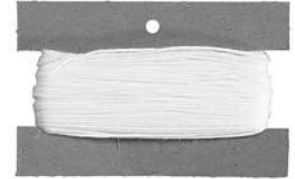

- High tensile strength
- Cotton cord

Item #	Size (ft.)
IR64610	100



STRINGLINER COMPANY
Fluorescent Line Reels

Original Stringliner:

- Quality #18 Braided Nylon Line
- Line Reel made of durable polyethylene
- Line secures in convenient notch



Stringliner Pro:

- Fits all line with 1" cores from 4" to 6" long
- Reload rolls of line easily
- Adjust to different lengths of cores
- Rewind hand crank
- Quality #18 Braided Nylon Line

Item #	Length	Color
Original Stringliner		
STL11462	250'	Pink
Stringliner Pro		
STL25459	500'	Orange
STL25462	500'	Pink



MARKAL
Lumber Crayon
Pro-EX®



- The clay-based "feel" that high-volume lumber crayon users prefer
- Stronger formula for reduced breakage
- Superior performance on wet wood

Item #	Color
LC80380	White
LC80381	Yellow
LC80382	Red
LC80383	Black
LC80385	Blue
LC80386	Green



MARKAL

Lumber Crayon Holders

#108 Holder



- Durable aluminum construction
- For use with 1/2" hexagonal lumber crayons, protects crayon from breakage; push-button operation
- Comes with leather wrist thong

Item #
LC85400

MARKAL

Lumber Crayon Holders

#109 Peterson Holder



- For all 1/2" hexagonal markers
- Made of durable hardwood
- Protects crayon from breakage; includes leather wrist thong

Item #
LC85490

MARKAL

B Paintstik®



- Weather-resistant, UV-resistant
- Real paint in stick form; marks through oil and water
- Ideal for layout, color coding, fabrication and identification
- Marks on smooth, rough, rusty, or dirty surfaces
- For use on metal, wood, plastic, concrete, rubber, glass, cardboard, and paper; lead-free, non-toxic
- Size: 11/16" x 4-3/4"

Item #	Color
LC84810	White
LC84811	Yellow
LC84812	Red
LC84813	Black
LC84814	Orange
LC84815	Blue
LC84816	Green

MARKAL

Dura-Ink® 25 Markers



King Size

- Broad chisel tip for bold marks; extra large ink supply
- Use on cardboard, wood, metal, paper, ceramics, glass & leather

Item #	Color
LC96222	Red
LC96223	Black

MARKAL

Soapstone Marker



- For temporary marking of metal surfaces
- Made of all natural soapstone for superior marking
- Marks will not contaminate welds and are easily removed
- Round 5-1/4" length

Item #
LC80130
LC80141 (Holder)

MARKAL

Paint Marker



Valve Action®

- Marks with real paint, dries in 3 minutes
- Nib releases paint as needed for continuous marking
- Marks on all surfaces including: metal, wood, glass, plastic, rubber, cardboard, and paper;
- Lead-free, low halogens
- The fiber nib is replaceable to assure complete use of each marker

Item #	Color
LC96820	White
LC96821	Yellow
LC96822	Red
LC96823	Black
LC96824	Orange
LC96825	Blue
LC96826	Green
LC96832	Aluminum



IRWIN INDUSTRIAL TOOLS

Carpenter Pencil Sharpener



- Uses 50% less pencil per sharpening cycle

Item #
IR233250

IRWIN INDUSTRIAL TOOLS

Carpenter Pencil

- 7" overall length

Item #
IR66300



IRWIN INDUSTRIAL TOOLS

Markers

Permanent Sharpie®

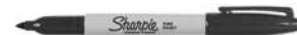

- Black permanent marker marks on wood, glass, plastic, metal, etc.

Item #
IR35010-SH



IRWIN
Industrial Tools

IRWIN INDUSTRIAL TOOLS

Markers

Permanent

Sharpie®



- A fine-tip marker designed to make a permanent impression on even the most hard-to-mark light and dark surfaces
- Features opaque metallic permanent ink in silver

Item #
IR39108-SH

IRWIN INDUSTRIAL TOOLS

Markers

Permanent

Sharpie®



- Blue fine-point permanent marker

Item #
IR30103-SH

IRWIN INDUSTRIAL TOOLS

Industrial Markers

King Size Sharpie®



- Industrial strength for tough marking jobs
- Marks on wet and oily surfaces
- Durable aluminum barrel and felt tip stand up to heavy use
- Special water resistant ink formula dries quickly
- Excellent for marking corrugate, wood, metal, foil, stone, plastic and leather and more

Item #	Color
IR15001-SH	Black
IR15002-SH	Red

**Ask us about the
“Green Beam” lasers.**

- **Better interior visibility**
- **Bright identifiable beam**

**Call Edge today to
schedule a demonstration
of any of our electronic
layout lasers.**



**Edge rents
& repairs
lasers**



CONSTRUCTION ELECTRICAL PRODUCTS

Trouble Lights

- Fluorescent trouble light with hook
- 25 ft. 16/3 ga. SJTW cord



Item #	Desc.	Watts
CEP1330FT	Fluorescent Trouble	13

CONSTRUCTION ELECTRICAL PRODUCTS

Economy Import Lights

Stubby

- Weatherproof and UL listed for use in wet locations
- One rough service quartz halogen bulb included with each fixture



Item #	Desc.	Watts
CEP5125-I	Stubby	500

CONSTRUCTION ELECTRICAL PRODUCTS

Quartz Floodlight

Magnetic Base

- 5" diameter magnetic base provides up to 200 lbs. of holding power
- On/Off switch on all units
- Vinyl cover on magnet protects surface to which it is attached
- 8' 16/3 SJTW power supply cord



Item #
CEP5050

CONSTRUCTION ELECTRICAL PRODUCTS

Heavy-Duty Work Lights

Quartz

- Weatherproof and UL listed for use in wet locations
- Folding tripod base and removable head assemblies for easy set-up and storage
- All steel stand and components
- 2-stage adjustable telescoping mast



Item #	Desc.	Height (ft.)	Watts
CEP5710	2 Fixture, w/switch	7	1000
CEP5750	1 Fixture, w/switch	7	500

CONSTRUCTION ELECTRICAL PRODUCTS

Economy Import Lights

Double Fixture

- Weatherproof and UL listed for use in wet locations
- One rough service quartz halogen bulb included with each fixture
- 3-stage adjustable telescoping mast



Item #	Desc.	Height (ft.)	Watts	Mast
CEP5610-I	Double Fixture w/switch	6	1000	3 Stage

CONSTRUCTION ELECTRICAL PRODUCTS

Economy Import Lights

Single Fixture

- Weatherproof and UL listed for use in wet locations
- One rough service quartz halogen bulb included with each fixture
- 3-stage adjustable telescoping mast



Item #	Desc.	Height (ft.)	Watts	Mast
CEP5650-I	Single Fixture w/switch	6	500	3 Stage

CONSTRUCTION ELECTRICAL PRODUCTS

Replacement Bulbs

- Replacement bulbs for work lighting

Item #	Type	Watts	Volts
CEP5911	Quartz Halogen	150	130



CONSTRUCTION ELECTRICAL PRODUCTS

Booster Cables

- Red and black vinyl jacket
- 12 ft. 6 ga. SJTW cable



Item #
CEP8612

CONSTRUCTION ELECTRICAL PRODUCTS

Tuff Plates Cord Protectors

- Durable protection for cables
- Width: 30"



Item #	Desc.	Rating	Length (in.)	Height (in.)
CEP3110	5 Chnl HD Cable Protector	40,000#	36	2.31
CEP3115	5 Chnl HD End Cap Set	40,000#	7.5/5.25	2.31
CEP3111	5 Chnl GP Cable Protector	20,000#	36	1.95
CEP3116	5 Chnl HD End Cap Set	20,000#	4.75	1.95



CONSTRUCTION ELECTRICAL PRODUCTS

3 Phase Distribution Panels

These heavy-duty 3 phase power distribution carts are designed to breakdown 3 phase 120/208V power into 208V 3 phase, 250V single phase and/or 125V single-phase power. The power supply input may be a direct wire feed, 100A pin and sleeve, or cam type devices. Either a large generator or another large power source may power them. These panels may be designed to act as the feeder for the smaller spider type boxes or wired for powering large equipment. The cart is made of heavy gauge tube steel and provides an easy means of transportation as well as protection for the enclosure. The enclosure is custom built from 16 gauge sheet metal. 100A, 200A, 400A and special configurations are available upon request.



- Heavy duty cart
- Clear breaker panel window
- Easily stackable
- GFCI protection available
- 3R and 4X available
- Stainless steel 16ga. enclosure
- UL Listed

Item #	Main Breaker Rating/Input Type	Output Receptacles (Qty./Nema#/Amp-Volt Rating)
CEP6210DC	100 Amp 120/280V Direct Wire	(10) 5-20R 20 Amp 125V Straight GFCI, (2) L6-30R 30 Amp 250 V Twist
CEP6211DC	100 Amp 120/280V Direct Wire	(4) L21-20R 20 Amp 120/208V Twist, (2) 5-20R 20 Amp 125V Straight GFCI
CEP6220CC	200 Amp 120/280V Cam Type	(6) CS6364 50 Amp 125/250V Twist, (2) L6-30 30 Amp 250V Twist, (2) L5-20 20 Amp 125V Twist GFCI
CEP6221CC	200 Amp 120/280V Cam Type	(8) L21-20 20 Amp 120/280V, (2) 5-20R 20 Amp 125V Straight GFCI
CEP6240CC	400 Amp 120/280V Cam Type	(8) Pin/Sleeve 60 Amp 125/250V, (2) 5-20R 20 Amp 125V Straight GFCI
CEP6241PC	400 Amp 120/280V Cam Type	(4) Pin/Sleeve 100 Amp 120/280V, (2) 5-20R 20 Amp 125V Straight GFCI

CONSTRUCTION ELECTRICAL PRODUCTS

480 Volt 3 Phase Power Station

Transformer Based

These heavy-duty 3 phase power distribution carts are designed to breakdown 3 phase 120/208V power into 208V 3 phase, 250V single phase and/or 125V single-phase power. The power supply input may be a direct wire feed, 100A pin and sleeve, or cam type devices. Either a large generator or another large power source may power them. These panels may be designed to act as the feeder for the smaller spider type boxes or wired for powering large equipment. The cart is made of heavy gauge tube steel and provides an easy means of transportation as well as protection for the enclosure. The enclosure is custom built from 16 gauge sheet metal. 100A, 200A, 400A and special configurations are available upon request.



- Heavy duty cart; stainless steel 16ga. enclosure
- Clear breaker panel window
- Easily stackable
- GFCI protection available
- 3R and 4X available
- Stainless steel 16ga. enclosure
- UL Listed

Item #	Transformer KVA Sizes	Primary Disconnect
CEP6214PDC15	15KVA	30A
CEP6210PDC30	30KVA	60A
CEP6212PDC30	30KVA	60A
CEP6220PDC45	45KVA	60A
CEP6220PDC75	75KVA	90A
CEP6221PDC75	75KVA	90A
CEP6240PDC150	150KVA	200A
CEP6241PDS150	150KVA	200A



PROBUILT PROFESSIONAL LIGHTING, LLC

Work Light

Wobblelight®

- The 36" tall Wobblelight® is a self righting, highly durable work light that takes a severe beating from workers, vehicles, debris, and drops with no bulb breakage
- Floating shock system protects bulb from jarring
- Impact resistant poly dome
- Internal ventilation system keeps exterior cool to the touch
- Power inlet/outlet
- Carrying handle
- Counter weighted design keeps light self-righting



Item #	Desc.	Coverage (ft.)
WL500H	500-watt Halogen	16-24
WL175MH	175-watt Metal Halide	30-42
WL400MH	400-watt Metal Halide	78-110

Accessories

WLD052195	175-watt Metal Halide (Bulb Only)	-
WLD052197	400-watt Metal Halide (Bulb Only)	-
WL0390318401	Light Dome and Cap Assembly	-
WL52230	Light Reflector Shield	-

PROBUILT PROFESSIONAL LIGHTING, LLC

Work Light

Wobblelight®

The 27" tall Wobblelight® Jr. is a self righting, highly durable light that can take rough handling at home or on the job.

- Integrated 5-foot power cord
- Low heat output; no hot surfaces
- Self-ballasted, instant-on technology
- Completely self-righting
- Tough, light-weight molded housing



Item #	Desc.	Coverage (ft.)
WL85SF	85-watt Spiral Fluorescent bulb	20+ lighting radius

PROBUILT PROFESSIONAL LIGHTING, LLC

Temporary Area Work Light

Hang-A-Light®

- Built in electrical receptacle allowing interconnectivity of up to 8 units on 120V / 15A service
- Self-Ballasted CFL Bulb: lightweight and flicker free with instant start-up
- Energy Efficient: Spiral Fluorescent gives bright 360° light with low-cost operation

Specifications:

- Lamp Type: Fluorescent
- Lumen Output: 6,900



Item #	Desc.	Coverage (ft.)
WL111105F	105-watt	20-30

PROBUILT PROFESSIONAL LIGHTING, LLC Uplight v2 Portable Task Light

Defender®

The ultimate in durability, portability and versatility. The 2-foot and 4-foot Defender® Uplight v2's have extremely tough housings and many innovative features. Lean it, lay it, stand it, hang it, or link it. This low current, high-output lighting tackles many tasks that other products can't, including confined spaces.

- Accessory outlet for linking units together
- IP44 design for dust and water resistance
- 15-ft. integrated power cord
- Non-slip rubber base for leaning against walls
- Removable reflector for 360° lighting; adjustable nylon strap
- Lamp life 20,000 hours
- CSA certified
- Optional wobble base available



Item #	Desc.
PBTE712505	2 Ft., 18 Watt Fluorescent
PBTE712500	4 Ft., 36 Watt Fluorescent

PROBUILT PROFESSIONAL LIGHTING, LLC

Eco Uplight Portable Self Standing Task Light

Defender®

The Defender® Eco Uplight is the ultimate tripod task light for durability, portability and versatility. Available in a 2 foot or 4 foot version, the integrated and collapsible legs open up to 30" diameter for exceptional stability. This low-current, high-output light tackles many tasks that other products can't, including confined spaces.

- Collapsible locking tripod base
- IP44 design for dust and water resistance
- 15-ft. power cord; adjustable nylon carrying strap
- Lamp life of 20,000 hours
- CSA certified



Item #	Desc.
PBTE712605	2 Ft., 18 Watt Fluorescent
PBTE712600	4 Ft., 36 Watt Fluorescent

PROBUILT PROFESSIONAL LIGHTING, LLC

Floor Lights

Defender®

Portable, lightweight, and durable, the Defender® Floor Lights deliver big brightness from a small package. Heavy-duty impact resistant housing keeps them on the job. Compact size goes into tight places and stores easily. Fluorescent and LED units available.

- IP44 design for dust and water resistance
- Rubberized carrying handle and base
- Highly polished reflector; low energy consumption
- Polycarbonate lens, 10-ft integrated power cord
- CSA certified



Item #	Desc.
PBTE709165	38 Watt Fluorescent
PBTE709187	64 LED



PROBUILT PROFESSIONAL LIGHTING, LLC
Rechargeable LED Hand Lamp
Defender®



Defender® Rechargeable LED Hand Lamp is water resistant and durable, with a tough housing and high-output LED's. It is perfect for small jobs and standard issue equipment for your tradesmen or maintenance teams.

- 26 High-output LEDs
- HI/Low setting
- Multi-positioning retainer; rechargeable NiMH batteries
- IP44 design for dust and water resistance
- Run time of 6 hours (low) and 3 hours (high)
- Supplied with 120V adapter/charge

Item #	Lumens	Lighting Area
PBTE712810	133	up to 8 ft. range



COLEMAN CABLE INC.
Work Light



- Grounded metal guard with side outlet and switch
- 25 ft. orange, 16/3 ga., SJT cord
- 75 watt maximum bulb

Item #
COL05427-88-03

COLEMAN CABLE INC.
Clamp Light



- Features a double ball universal joint, non-marring grips and a clamp-on bracket
- On off push through switch and rugged molded-on plug
- 8-1/2" diameter reflector; 6 ft. cord

Item #
COL05932-00-57

COLEMAN CABLE INC.
Temporary Light Strings
Cord-O-Lite™



- Plastic guards
- Heavy-duty 12/3 SJTW (yellow) cord with molded light sockets
- Accommodates A-23 bulbs up to 150 watts
- NEC compliant; meets OSHA requirements; UL listed

Item #	Length (ft.)
COL07549-88-02	100
COL07548-88-02	50

COLEMAN CABLE INC.

Replacement Guards

- Replacement guard

Item #	Desc.
COL07200-20-00	Coated Metal
COL07500-00-00	Plastic



COLEMAN CABLE INC.

400W Metal Halide Temporary Lighting

Features:

- Energy Efficient and Long Life 400W Metal Halide Bulb
- Quick installation with spring-loaded hanger
- Heavy gauge steel guards to resist damage
- Quad-tap ballast (120v, 208v, 240v, 277v)



Item #
COL07605-88-00

Replacement Bulb
COL07625

WMSI

Light Bulbs

- Incandescent, frosted
- Contractor grade; 120 per case

Item #	Desc.
MID00378	75W Tough Coat
MID00391	100W Tough Coat
MIDL75	75W Rough Service
MIDL100	100W Rough Service



WARNER TOOL

Quartz Halogen Bulb

- 500 watt/130 volt replacement bulb
- Type J T-3 bulb

Item #
DDSB2000



WARNER TOOL

Magnetic Worklight

- 500 watt weatherproof fixture
- 16 gauge, 8 ft. heavy-duty cord
- Powerful 40 lb. pull strength magnet

Item #
DDBD-MAG





RAYOVAC
6-Volt Industrial Lantern

Krypton Bulb

- Includes: 6 Volt Heavy Duty Battery and Flip Stand
- 4187 peak beam candlepower
- Withstands five foot drop tests, weatherproof construction
- Extra-wide reflector with super bright krypton bulb provide a long range beam



Item #
RYI6V-B2

RAYOVAC
Yellow Industrial Flashlight

2 Cell D Size

- Hanging ring on end cap for convenient hang-up storage
- 1115 peak beam candlepower
- Withstands seven foot drop tests, weatherproof construction



Item #
RYIN2

RAYOVAC
Yellow Industrial Flashlight

Magnetic 2 Cell D Size

- Powerful magnet for positioning and storage
- 2000 (KPR102), 985 (PR2) peak beam candlepower
- Withstands seven foot drop tests, weatherproof construction
- With krypton bulb



Item #
RYIN2-KML

RAYOVAC
Orange Industrial Safety Flashlight

2 Cell D Size

- Safety head and ring hanger
- 985 peak beam candlepower
- Approved for use in hazardous locations by UL and MSHA
- Withstands seven foot drop tests, weatherproof construction



Item #
RYIN2-MS

RAYOVAC
Yellow Industrial Value Flashlight

Magnetic 2 Cell D Size

- Strong magnet for positioning and storage, hanging lanyard
- 2750 peak beam candlepower



Item #
RYIV2DM

RAYOVAC
Industrial Flashlight
Roughneck™

- Shock absorbing bulb system, it withstands a 7-10 foot drop test
- Has spot-to-flood focus capabilities and is water resistant



Item #	Desc.
RYR2AA-BA	2 Cell AA Size Light w/Batteries
RYR2D	2 Cell D Size Light w/o Batteries
RYR3D	3 Cell D Size w/o Batteries

RAYOVAC
Rubber/Aluminum Flashlight

- Krypton bulb - 50% brighter than a standard bulb
- Durable rubber and aluminum construction
- Soft comfort grip
- Easy push button switch
- Handy lanyard to carry or hang
- Lifetime Warranty



Item #	Desc.
RY2AA-B RB	Uses 2 AA Batteries (included)
RY2D-B RB	Uses 2 D Batteries (included)

RAYOVAC
Industrial™ 2AA Swivel-Lite™

- High intensity bulb
- Smooth beam with prismatic reflector for close-in use
- 2-way Swivel
- 90° pivoting head
- 360° swivel around
- Hands-free with pocket or belt clip
- Easy battery replacement door
- Lifetime Warranty
- Uses 2AA Batteries (included)
- Replacement Bulb: T1



Item #
RYILJ2AA-B



RAYOVAC

Industrial™ 2D Swivel-Lite™

- Krypton bulb with spare bulb holder
- Durable rubber end cap & lens ring
- Rubber comfort grip
- 90° Swivel
- 5 foot drop tested; sturdy hang ring
- Lifetime Warranty
- Uses 2D Batteries (included)
- Replacement Bulb: K2



Item #
RYISL2D-B

RAYOVAC

Flex360™ LED Clamp Flashlight RoughNeck™

- High performance LED, 130 lumens with adjustable spot to flood beam
- Grips onto anything to make the job trouble free
- Use the magnet to illuminate from a metal beam, car hood, etc.
- The flexible head rotates 180 degrees and pivots 90 degrees
- Run time is 12 hours on high, beam distance 130 meters, 415 feet
- Runs on 3 AAA batteries that are included



Item #
RYYNC3AA-B

RAYOVAC

3-1 LED Headlight

3 AAA Cell Size

- 2 Red LED's for improved night vision
- 2900 peak beam candlepower
- 1 Super bright white LED for close in viewing / Low beam - LED
- Long range T3 Krypton bulb with "spot to flood" focus
- Withstands five foot drop tests, weatherproof construction



Item #
RYSPHLTLED

RAYOVAC

Krypton Replacement Bulbs

- Flanged Base
- 2/Card



Item #	Desc.
RYK13-2	6-Volt Applications
RYK3-2	3 Cell D Size Flashlight

RAYOVAC

Industrial Alkaline Batteries

- Shrink wrapped

Item #	Desc.	Qty. per Pack
RYAL-AA	AA	8
RYAL-AAA	AAA	8
RYAL-C	C	6
RYAL-D	D	6
RYAL-9V	9V	6



RAYOVAC

Industrial Lantern Batteries

- 6-Volt
- Spring terminals
- Heavy-duty maximum



Item #
RY6V-HDM



PELICAN PRODUCTS

Industrial Flashlights

MityLite® Laser Spot™

- Fits into pockets, glove compartments, tool boxes etc.
- 400% brighter than ordinary pocket lights with a pre-focused Xenon beam
- Requires 2 AAA-cell Alkaline batteries
- Length 4-3/4", Diameter 5/8"



Item #	Color
PU1900C	Black
PU1904	Lamp/Module

PELICAN PRODUCTS

Industrial Flashlights

MityLite™

- Small powerful maintenance light with an exceptionally wide beam
- Built to perform in the most severe conditions: water, rain, snow and fog
- Requires 2 AA-cell Alkaline batteries
- Length 5-1/2", Diameter 1-1/4"



Item #	Color
PU2340B	Black
PU2304	Lamp Module



PELICAN PRODUCTS

Compact Flashlight

MityLite™



- Perfect for general use, around the house or at work
- Push button tail switch for one hand operation
- Hands-free use, attach it to your helmet or hard hat with clip included
- Powered by 4 AA Alkaline cell batteries
- 4 Hour Battery Burn Time

Item #	Color
PU2430C	Yellow

PELICAN PRODUCTS

Flashlights

Pocket SabreLite™



- Complete with xenon lamp module and lanyard
- Batteries: 2 C Alkaline
- Battery Burn Time: 7.5 hrs.
- Length: 5-13/16"

Item #	Color
PU1820C	Yellow

PELICAN PRODUCTS

Industrial Flashlights

Super SabreLite® Laser Spot™



- Most approved industrial quality flashlight in the world today for hazardous location use
- Submersible to 500 ft., has more fail safe features than any industrial flashlight made
- Requires 3 C-cell Alkaline batteries

Item #	Color
PU2000C	Black

PELICAN PRODUCTS

Flashlights

L1 LED Light



- Water resistant. LED flashlight provides up to 50,000 hours of built tough light
- Uses 4 LR44 1.5V Alkaline coin cells for up to 130 hours of battery life
- 2 night vision discs: red and blue/green
- Length: 2-5/8"; Candle Power: 6000; Battery Burn Time: 130 hrs.

Item #	Color
PU1930C	Yellow

PELICAN PRODUCTS

Flashlights

StealthLite™



- Built to perform in the most severe conditions
- Submersible to 500' with an unbreakable corrosion proof ABS body and high impact polycarbonate lens
- 4 AA-cell batteries; 10,000 candle power
- Length: 6-1/2"

Item #	Color
PU2400B	Yellow
PU2404	Lamp Module

PELICAN PRODUCTS

Industrial Flashlight

VersaBrite™ Deluxe



- Easily clips onto caps, shirts, coats, belts, or attaches to almost anything
- The prefocused Xenon laser beam penetrates fog, smoke, and dust
- Includes 2 nite vision lens, (1) red and (1) blue/green
- Velcro® mounting system, adjustable hard hat/headband, and 2 AA-cell batteries

Item #	Color
PU2250	Black
PU2204	Lamp Module

PELICAN PRODUCTS

Industrial Flashlight Holders

Helmet Lite Holder For Pelican Lights



- Designed to fit all hard hats and helmets without drilling or gluing
- Fits all VersaBrite, MityLite, Super MityLite, MityLite Magnum, StealthLites plus other brand lights

Item #
PU700

PELICAN PRODUCTS

Industrial Flashlights

Heads Up Lite™



- Provides hands free light to the exact area needed
- The powerful Krypton beam adjusts from spot to flood
- A comfortable fit is provided by the large, firm but soft head pad and elastic cloth strap
- A large on/off switch is easy to operate
- Made of corrosion proof ABS polymer
- Includes 4 AA-cell batteries, 2 Krypton lamps
- Submersible to 500 feet
- Weight: 5.4 oz

Item #
PU2600CS



PELICAN PRODUCTS

Remote Area Lighting System

Combines tough 1510 Case with 16 x 1 watt LEDs mounted in an aluminum heat sink. All items are stored inside the case and assemble in minutes. The aluminum pole extends to a height of 83" to provide 1280 lumens of light for any area. The rechargeable battery has 9 hours of life at maximum output tailing off to low light level at hour 17. The diffuser (included) can be mounted to change the beam from a focused spot to a diffused beam.



- Now RoHS Compliant; almost 10 lbs. lighter; new power panel
- Booklet and reference card included; battery status indicator lights
- Pole storage located conveniently inside the base of the case

Item #
PU9450R.A.L.S.



MAGLITE®

D-Cell Flashlights

- High strength aluminum alloy case
- O-ring sealed for water resistance
- 1/2 turn, cam-action focus, spot-to-flood
- 3 position switch - on, off, signal



Item #	Size	Bulb
MLS2D016	2D	Krypton
MLS3D016	3D	Krypton
MLST2D016	2D	LED

MAGLITE®

Mini Flashlights

- High-strength alloy aluminum case
- O-ring sealed for water resistance; candle mode
- 1/2 turn, twist focus, spot-to-flood



Item #	Size	Bulb
MLM2A016	AA	Krypton
MLM3A016	AAA	Krypton
MLSP2201H	AA	LED

MAGLITE®

Solitaire Flashlight

- High-strength aluminum alloy case
- O-ring sealed for water resistance
- Extended key lead for easy use
- Twist focus, spot-to-flood



Item #	Size	Bulb
MLK3A016	AAA	High Intensity

MAGLITE®
Replacement Bulbs

- 2 Pack

Item #	For Flashlight	Type
MLLWSA201	2D	Krypton
MLLWSA301	3D	Krypton
MLLM2A001	AA Mini	Krypton
MLLM3A001	AAA Mini	High Intensity



COLEMAN CABLE INC.
Extension Cords

Polar/Solar®

- Polar/Solar™ cord will not crack, peel, flake or bake out even in the most bitter arctic cold
- Lightweight and stays flexible to -67°F
- Rugged T*Prene insulation provides superior resistance to abrasion, ozone, oil, grease and chemicals and cold weather
- Power indicator light in the female receptacle to show that the power is on
- UL Listed & CSA Certified outdoor use cord set
- Meets OSHA requirements for outdoor use



Item #	Wire Ga/Cond	Length (ft.)	125V Rating
COL01487-00-02	14/3	25	15A
COL01488-00-02	14/3	50	15A
COL01489-00-02	14/3	100	13A

COLEMAN CABLE INC.

Multi-Outlet Extension Cord

3-Way

Polar/Solar™

- Lightweight and stays flexible to -67°F
- Plug in up to three (Tri-Source) tools in this unique female receptacle
- Power indicator light in female end to show that the power is on
- UL Listed & CSA Certified outdoor use cord set
- Meets OSHA requirements for outdoor use



Item #	Wire Ga/Cond	Length (ft.)	125V Rating
COL03489-00-02	12/3	100	15A

COLEMAN CABLE INC.

Extension Cord

3-Way Power Block

Polar/Solar™

- Three outlet cord connector with power indicator light; UL listed adapter cord set
- Cord rating: Extra Hard Usage per the National Electrical Code; CUL listed or CSA certified
- Cable temperature rating: -50 to +90°C



Item #	Wire Ga/Cond	Length (ft.)	125V Rating
COL03482-00-22	12/3	2	15A



COLEMAN CABLE INC.

Multi-Outlet Extension Cords

3-Way Vinyl



- Provide additional outlets for power distribution
- Vinyl jacket resists moisture, abrasion, and prolonged exposure to sunlight
- UL/cUL/ETL Listed
- Meets OSHA requirements for outdoor use

Item #	Wire Ga/Cond	Length (ft.)	125V Rating
COL04189-88-02	12/3	100	15A
COL04188-88-02	12/3	50	15A
COL04187-88-02	12/3	25	15A

COLEMAN CABLE INC.

Extension Cords

Vinyl Outdoor



- Vinyl jacket resists moisture, abrasion and prolonged exposure to sunlight
- Three conductor lighted end
- UL/cUL/ETL Listed/Meets OSHA requirements for outdoor use

Item #	Wire GA/Cond	Length (ft.)
COL02587-88-02	12/3	25
COL02588-00-02	12/3	50
COL02589-00-02	12/3	100
COL02688-88-02	10/3	50
COL02689-88-02	10/3	100

COLEMAN CABLE INC.

Extension Cords

Vinyl



- UL Listed - Meets OSHA requirements for outdoor use
- Vinyl insulation resists oil, grease, moisture, abrasion and prolonged exposure to sunlight
- Heavy-duty molded-on plugs and connectors

Item #	Wire Ga/Cond	Length (ft.)	125V Rating
COL02408-88-04	14/3	50	15A
COL02409-88-04	14/3	100	13A

COLEMAN CABLE INC.

Portable Power Cable Box

X-Treme Box™



- Portable power distribution center rainproof NEMA 3R
- (6) 20A power outlets GFCI and circuit breaker protected Nema 5-20 straight blade receptacles with covers
- Made in the USA
- Complies with OSHA and NEC specifications
- 30A Power outlet: 250v L6-30R Twist-to Lock w/Cover
- 50A Power outlet/50A Power Inlet 125/250v Twist-to-Lock w/covers
- Overload, Over-Voltage & Open-Neutral Protection: 50A- None, 30A-Circuit Breaker Protected, 20A GFCI & Circuit Breaker Protected

Item #
COL01970-3R-02

COLEMAN CABLE INC.

Mini Portable Power Distribution Box

Mini X-Treme Box™



Features:

- Compact size for ease of use
- Reduces electrical hookup and labor time
- 8 overload, circuit breaker protected 20 amp straight blade outlets
- May be used in vertical or horizontal positions

Applications:

- Provide economical, durable temporary jobsite power

Industry Approvals:

- Complies with OSHA and NEC specifications
- ETL listed

Item #
COL01980

COLEMAN CABLE INC.

Power Distribution Extension Cords



- Temporary power cords are manufactured using rugged 600-volt Type SEOW cable and provide a superior alternative to ordinary SO cords
- Type SEOW constructions provide greater abrasion/wear resistance for longer cord life and its lightweight will make job site transportation easier
- These cords are designed for use with temporary power distribution centers with input current of 50 amps, 125/250 volt AC, 3-pole, and 4 wire

Item #	Length (ft.)	End Type
COL01918-00-08	50	Hubbell
COL01919-00-08	100	Hubbell



COLEMAN CABLE INC.
Cord Adapters

Twist-to-Lock U-Ground

- Standard 15P U-Ground receptacle (NEMA 5-15P)
- Twist-To-Lock 20A Plug (NEMA L5-20R)



Item #	Wire Ga/Cond	Length (in.)
COL09020-88-02	12/3	9

COLEMAN CABLE INC.
Cord Adapters

Twist-to-Lock U-Ground

- Twist-To-Lock 20A Plug (NEMA L5-20P)
- Standard 15A U-Ground receptacle (NEMA 5-15R)



Item #	Wire Ga/Cond	Length (in.)
COL09021-88-02	12/3	9

COLEMAN CABLE INC.
Extension Cord "Y" Adapters

Twist-to-Lock

- Yellow, STW Wire type



Item #	Wire Ga/Cond	Length (in.)	125V Rating
COL09022-88-02	12/3	20	20A

COLEMAN CABLE INC.
Extension Cord Adapter

"W" Adapter

- 12/3 STW 125V/15A Outdoor use straight-blade "W"-adapter cord set
- UL Listed



Item #	Wire Ga/Cond	Length (ft.)	125V Rating
COL09019-88-02	12/3	2	15A

COLEMAN CABLE INC.
Outlet Adapters

- Convert single outlet into three grounded outlets
- Orange color

Item #
COL09906-88-03



COLEMAN CABLE INC.
GFCI Cord



Right Angle

- Complies with OSHA requirements for personnel protection in temporary wiring installations
- Attachment plug configuration: Right-angle plug-in GFCI, NEMA 5-15P
- Cord connector configuration: NEMA 5-15R
- Operating environment: Rain proof plug-in GFCI, outdoor rated cord set
- Max operating wattage: 1800 W

Item #	Wire Ga/Cond	Length (ft.)
COL02834-88-02	12/3	2

COLEMAN CABLE INC.
GFCI Adaptor

Plug-In w/Surge Protection

- Made with thermoplastic protective housing
- Convert your extension cords, tools and equipment to add GFCI protection
- Provide personal protection from ground faults and open neutral conditions anywhere electrical equipment is used
- UL Listed/Meets OSHA specifications



Item #
COL02800-00-01

COLEMAN CABLE INC.
GFCI Cord

Quad Box

- Quad boxes have high impact resin with a slant-roof design to prevent water entry; receptacles can accommodate large plugs
- Provide personal protection from ground faults and open neutral conditions anywhere electrical equipment is used
- Protection for the job site, plant floor or workshop
- UL Listed/Meets OSHA specifications



Item #	Wire Ga/Cond	Length (ft.)	120V Rating	Relay Capacity
COL02816-88-02	12/3	6	15A	25A



MARINCO LLC
Temporary Power Plug

- 50 Amp Nylon Device
- 3 Pole/4 Wire, 125/250 Volt

Item #	Desc.
MARCS6364N	Female Connector
MARCS6365N	Male Plug



Woodhead molex

WOODHEAD Hand Lamps Safeway® Drop-Lite®

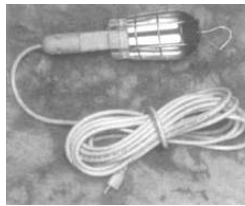

- Molded nylon handle with switch and side outlet
- Heavy plated steel guard
- 16/3 SJTOW cord
- Molded NEMA 5-15 plug
- UL listed
- Max. Bulb Size: 100 W
- Side Outlet: 120 V

Item #	Length (ft.)
DW402	25
DW405	50

WOODHEAD Plugs Super-Safeway®



- For rigorous, abrasive industrial applications
- Durable rubber housing resists heat, oil impact and chemicals
- Self-centering cord clamp provides superior strain relief

Item #	Wiring Configuration	NEMA Configuration	Rating
DW1433	2 Pole/3 Wire	5-20	20 A/125 V
DW1447	2 Pole/3 Wire	5-15	15 A/125 V
DW1448	2 Pole/3 Wire	6-20	20 A/250 V
DW1449	2 Pole/3 Wire	6-15	15 A/250 V
DW2407	3 Pole/3 Wire	Non-NEMA Locking	15 A/125 V/10 A/250 V
DW2447	2 Pole/3 Wire	L5-15	15 A/125 V
DW2608	3 Pole/3 Wire	Non-NEMA Locking	20 A/125 V/250 V
DW2647	2 Pole/3 Wire	L5-20	20 A/125 V
DW2648	2 Pole/3 Wire	L6-20	20 A/250 V
DW2809	4 Pole/4 Wire	Non-NEMA Locking	30 A/120 V/208 V
DW2847	2 Pole/3 Wire	L5-30	30 A/125 V
DW2848	2 Pole/3 Wire	L6-30	30 A/250 V
DW5166	2 Pole/2 Wire	1-15	15 A/125 V
DW5266	2 Pole/2 Wire	1-15	15 A/125 V

WOODHEAD Multiple Outlet Box

- Made of durable rubber to withstand impact of drops, bumps
- Two duplex receptacle, 3-3/8" depth
- NEMA configuration 5-15

Item #
DW3000-1



WOODHEAD Connectors Super-Safeway®



- For rigorous, abrasive industrial applications
- Durable rubber housing resists heat, oil impact and chemicals
- Self-centering cord clamp provides superior strain relief

Item #	Wiring Config.	NEMA Config.	Rating
DW1533	2 Pole/3 Wire	5-20	20 A/125 V
DW1547	2 Pole/3 Wire	5-15	15 A/125 V
DW1548	2 Pole/3 Wire	6-20	20 A/250 V
DW1549	2 Pole/3 Wire	6-15	15 A/250 V
DW2507	3 Pole/3 Wire	Non-NEMA Locking	15 A/125 V/10 A/250 V
DW2547	2 Pole/3 Wire	L5-15	15 A/125 V
DW2708	3 Pole/3 Wire	Non-NEMA Locking	20 A/125 V/250 V
DW2709	4 Pole/4 Wire	Non-NEMA Locking	20 A/120 V
DW2747	2 Pole/3 Wire	L5-20	20 A/125 V
DW2748	2 Pole/3 Wire	L6-20	20 A/250 V
DW2909	4 Pole/4 Wire	Non-NEMA Locking	30 A/120 V/208 V
DW2947	2 Pole/3 Wire	L5-30	30 A/125 V
DW2948	2 Pole/3 Wire	L6-30	30 A/250 V
DW5169	2 Pole/2 Wire	1-15	15 A/125 V
DW5269	2 Pole/3 Wire	5-15	15 A/125 V

WOODHEAD Industrial-Duty Adapters Safeway®



- Nylon Adapter
- CSA approval LR6837

Item #	Receptacle (Female End)	Plug (Male End)	Limited Use Applications
DW1730	20A/125V Nema 5-20	20A/250V Non-Nema	For use only with receptacles wired for 125V single-phase grounding service
DW1732	20A/250V Non-Nema	15A/125V Nema 5-15	For use only with receptacles wired for 15A/125V single-phase grounding service

WOODHEAD Lampholder Socket

Watertite®

- Rubber cover construction with water-resistant lip that molds around bulb
- Ceramic base interior with full-thread copper screw shell, medium base
- #14 gauge wire leads
- 600 Volt, 300 Watt, maximum 15A



Item #
DW606



Woodhead
INDUSTRIES

WOODHEAD
Pendant Control

Watertite®

- Switches are single speed, double throw, momentary contact type
- Nylon enclosure and coverplate with rubber pushbutton diaphragm that provides water tight integrity



Item #	Cord Diameter Range (in.)
DW4052	0.312 - 0.625

WOODHEAD
Cord Reel

- Steel rod frame and handle with wide base
- Heavy gauge steel flanges
- Large rewinding knob
- Four receptacles, rated 15A-125V
- Receptacle NEMA configuration 5-15
- Stores up to 150 ft. of 12/3 or 200 ft. of 14/3 50W cord



Item #
DW910

RAYOVAC

RAYOVAC
Headlight

- 80 Lumens (target)
- Adjustable Spot to Flood Beam
- Multi-Use: Headlight, Magnet, Hat Clip, Helmet
- Includes 2 headstraps: Cloth & rubber
- Water Resistant
- 3AAA Batteries Included



Item #
RYRNHL3AAA-B

RAYOVAC
Flashlight

- 3 Modes: Low, High, & Strobe
- 200 Lumens (high) 70 Lumens (low)
- Spot to Flood
- Beam Distance: 130 meters (415')
- 3AAA Alkaline Batteries Included
- Aluminum Body
- Water Resistant
- Holster Included



Item #
RYRNT3AAA-B

Buy Or Rent
Cords, Power Distribution Boxes, Lights, . . .

Ask about Custom Cords

- Loss Prevention: With name imprint and/or company colors
- Hi-visibility colors for safety: Reduce severing and tripping
- Manufactured in the USA: Faster turnaround

Let Edge help with solutions for Temporary Lighting

- Extension Cords to Light Strings
- Portable Lights to Light Towers
- Temp boxes and cords to Distribution Panels

See other chapters for our Generators

Unistrut General Notes

Standard Material

- Channel – cold formed steel
- Fittings – hot rolled steel

Finishes Available

- Electro-galvanized (EG) for fittings
- Pre-galvanized (PG) for channel
- Hot-dip galvanized (HG)
- Perma-Green III (GR)
- Plain (PL)
- Ask about custom powder-coating

Special materials available

- 304 stainless (SS)
- 316 stainless (ST)
- Aluminum
- Fiberglass

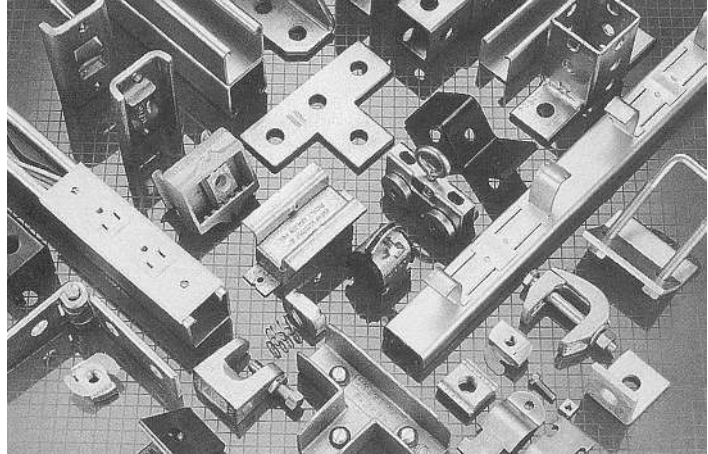

General:

- US Made – All Unistrut products are manufactured domestically - ask for details to meet your specific requirements
- Certificates of Conformance available upon request
- Not all products are shown in this catalog – ask for a more detailed Unistrut catalog to see a full listing of products
- Load data – inquire about detailed loading information or a Unistrut catalog
- LEED points – ask how you can obtain LEED points for this product
- Bolt torques – inquire about recommended bolt torque
- Seismic – ask for assistance with products to meet your seismic restraint needs
- Design assistance & material take-offs – see our Engineered Systems section for more details – call for assistance with design and material take-offs

Unistrut Channel Options:

- Standard channel lengths are 10' and 20'. If you require longer lengths, call Edge for more information.
- Curved channel – call for more information
- Cutting & assembly – call Edge for more information and a quote
- Gauge – most channel is 12ga – ask about other gauges
- Holes/slots – most channel is either solid or “T” slotted – ask about other hole and slot configurations (refer to chart) – holes and slots generally reduce load capacity by 5% to 30%

Standard Dimensions for 1-5/8”(41mm) width series channel fittings (unless otherwise shown or noted)

- Hole Diameter: 9/16” (14mm)
- Hole Spacing – From End: 13/16” (21mm)
- Hole Spacing – On Center: 1-7/8” (48mm)
- Width: 1-5/8” (41mm)
- Thickness: 1/4” (6mm)



Complete List of Available Unistrut Channel Combinations and Sizes
(Call for more details)

P1000 Series (12 ga.)

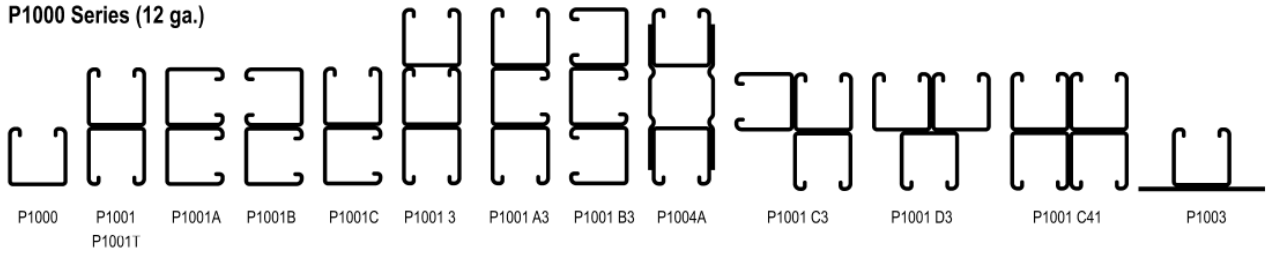

P1100 Series (14 ga.)

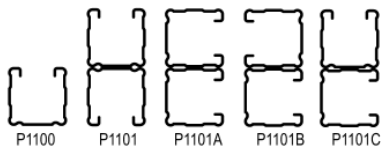

P2000 Series (16 ga.)

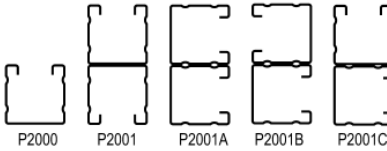

P3000 Series (12 ga.)

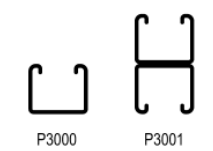

P3300 Series (12 ga.)

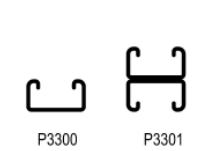

P4100 Series (14 ga.)

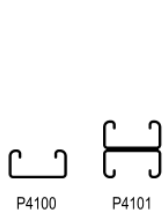

P4000 Series (16 ga.)

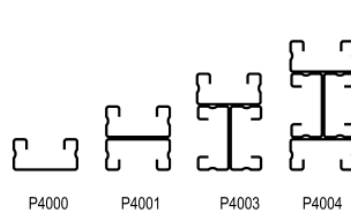

P5000 Series (12 ga.)

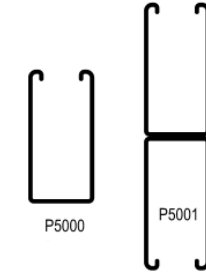

P5500 Series (12 ga.)

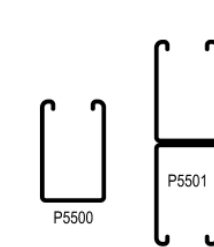

**P9000 Series (12 ga.)
Telestrut Channel**

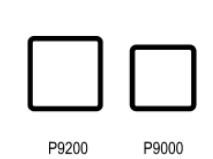

End Caps and Frame Caps

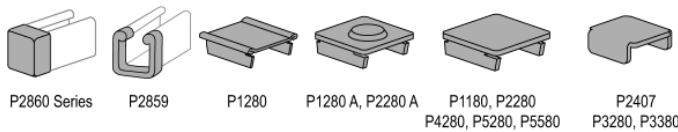

1 5/8" Channel Closure Strips



Alternate Framing Systems

A1000 Series (14 gauge) – 1 1/4" Channel

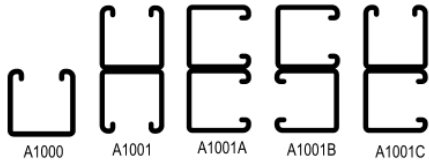

**A3300 Series (14 gauge)
1 1/4" Channel**



**A4000 Series (19 gauge)
1 1/4" Channel**



**A5000 Series (14 gauge)
1 1/4" Channel**

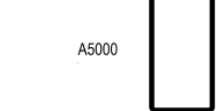

P6000 Series (19 gauge) – 1 3/16" Channel

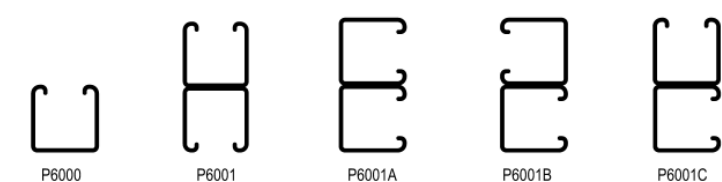

**P7000 Series (19 gauge)
1 3/16" Channel**

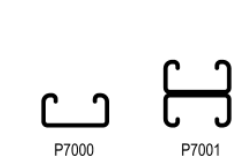

CHANNEL SELECTION CHART

Channel	Channel Dimensions		Material & Thickness			Hole Pattern Styles					
			Steel gauge	Stainless Steel gauge	Alum. In (mm)						
	In (mm)	In (mm)				HS	T	Steel Only			
P1000	1 1/2 (41)	1 1/2 (41)	12 ga	12 ga	0.109 (2.8)	■	■	■	■	■	■
P1100	1 1/2 (41)	1 3/8 (41)	14 ga	14 ga	—	■	■	■	■	-	-
P2000	1 1/2 (41)	1 3/4 (41)	16 ga	—	—	■	■	■	■	-	-
P3000	1 1/2 (41)	1 3/8 (35)	12 ga	—	—	■	■	■	■	-	-
P3300	1 1/2 (41)	7/8 (22)	12 ga	12 ga	—	■	■	-	■	-	-
P4000	1 1/2 (41)	1 3/16 (21)	16 ga	16 ga	0.078 (2.0)	■	■	-	■	-	-
P4100	1 1/2 (41)	1 3/16 (21)	14 ga	—	—	■	■	-	■	-	-
P5000	1 1/2 (41)	3/4 (83)	12 ga	12 ga	—	■	■	■	■	-	-
P5500	1 1/2 (41)	2 1/16 (62)	12 ga	—	0.109 (2.8)	■	■	■	■	-	-

CHANNELS & COMBINATIONS IN DESCENDING ORDER OF STRENGTH

Channel	Area In ² (cm ²)	Weight lbs/ft (kg/m)	I In ⁴ (cm ⁴)	s In ³ (cm ³)	Allow. Moment In-lbs (N*m)
P5001	1.793 11.57	6.10 9.1	6.227 259.2	1.916 31.4	48,180 5,440
P1004A	1.965 12.68	6.68 9.9	4.068 169.3	1.669 27.4	41,980 4,740
P5501	1.452 9.37	4.94 7.3	2.805 116.8	1.151 18.9	28,940 3,270
P1001C41	2.221 14.33	7.55 11.2	1.856 77.2	1.142 18.7	28,720 3,250
P5000	0.897 5.78	3.05 4.5	1.098 45.7	0.627 10.3	15,770 1,780
P1001	1.111 7.16	3.78 5.6	0.928 38.6	0.571 9.4	14,360 1,620
P1101	0.835 5.39	2.84 4.2	0.733 30.5	0.451 7.4	11,340 1,280
P3001	1.000 6.45	3.40 5.1	0.591 24.6	0.430 7.0	10,810 1,220
P5500	0.726 4.68	2.47 3.7	0.522 21.7	0.390 6.4	9,820 1,110
P2001	0.684 4.41	2.32 3.5	0.618 25.7	0.381 6.2	9,570 1,080
P9200	0.489 3.16	2.23 3.3	0.279 11.6	0.297 4.9	7,480 850
A5000	0.492 3.17	1.67 2.5	0.358 14.9	0.265 4.3	6,670 750
A1001	0.609 3.93	2.07 3.1	0.302 12.6	0.242 4.0	6,070 690
P9000	0.387 2.50	1.88 2.8	0.166 6.9	0.205 3.4	5,150 580
P1000	0.555 3.58	1.89 2.8	0.185 7.7	0.202 3.3	5,070 570
P3301	0.790 5.10	2.69 4.0	0.176 7.3	0.201 3.3	5,060 570

Channel	Area In ² (cm ²)	Weight lbs/ft (kg/m)	I In ⁴ (cm ⁴)	s In ³ (cm ³)	Allow. Moment In-lbs (N*m)
P1100	0.418 2.69	1.42 2.1	0.145 6.0	0.162 2.6	4,060 460
P3000	0.500 3.23	1.70 2.5	0.120 5.0	0.153 2.5	3,850 430
P4101	0.579 3.74	1.97 2.9	0.117 4.9	0.143 2.4	3,610 410
P2000	0.342 2.21	1.16 1.7	0.125 5.2	0.140 2.3	3,520 400
P4001	0.478 3.14	1.66 2.5	0.104 4.3	0.128 2.1	3,210 360
A3301	0.459 2.96	1.56 2.3	0.077 3.2	0.103 1.7	2,590 290
A1000	0.305 1.96	1.04 1.5	0.061 2.5	0.086 1.4	2,170 250
P3300	0.395 2.55	1.34 2.0	0.037 1.5	0.072 1.2	1,800 200
A4001	0.264 1.70	0.90 1.3	0.037 1.5	0.058 1.0	1,470 170
P6001	0.213 1.38	0.73 1.1	0.045 1.9	0.055 0.9	1,400 160
P4100	0.290 1.87	0.98 1.5	0.026 1.1	0.054 0.9	1,360 150
P4000	0.244 1.57	0.83 1.2	0.023 0.9	0.049 0.8	1,230 140
A3300	0.230 1.48	0.78 1.2	0.017 0.7	0.038 0.6	950 110
A4000	0.132 0.85	0.45 0.7	0.008 0.3	0.022 0.4	560 60
P6000	0.107 0.69	0.36 0.5	0.009 0.4	0.020 0.3	510 60
P7001	0.148 0.96	0.50 0.8	0.007 0.3	0.018 0.3	460 50
P7000	0.074 0.48	0.25 0.4	0.002 0.1	0.007 0.1	170 20

Combinations not shown in catalog are available on special order. Call for more details.

Complete List of Unistrut Fittings Available (Call for more details)

Flat Plate Fittings

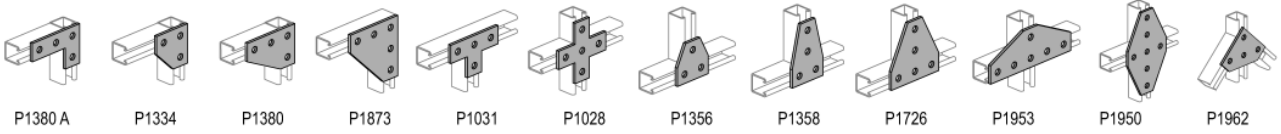
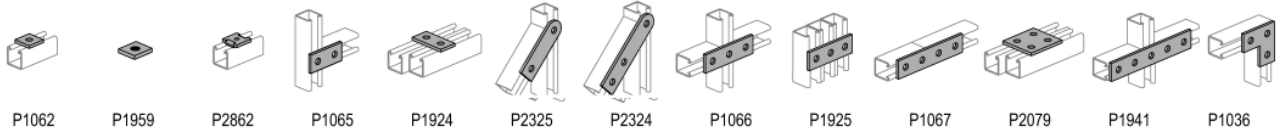

Angle Fittings

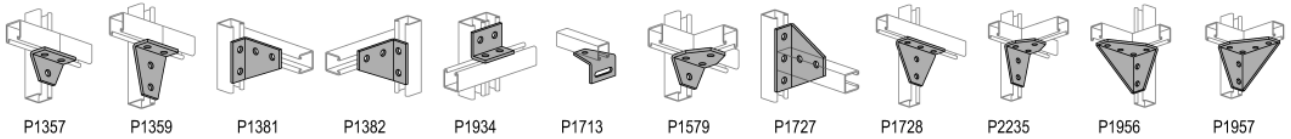
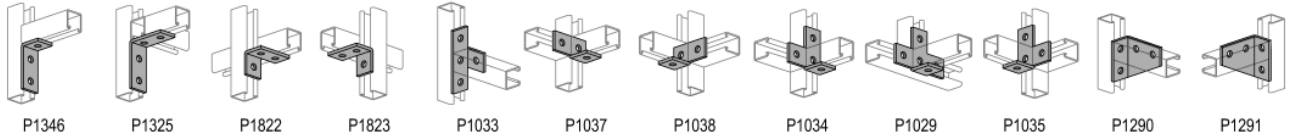
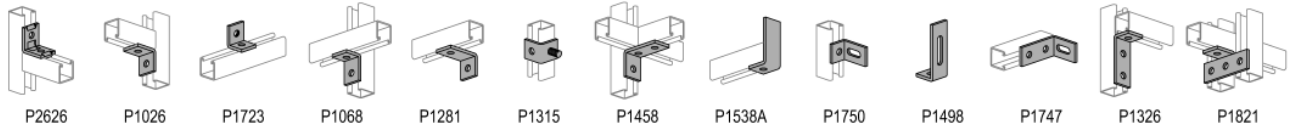

"Z" Shape Fittings

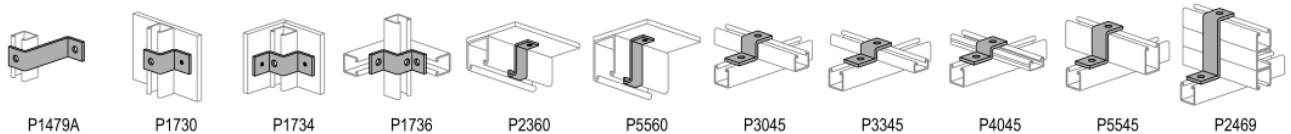
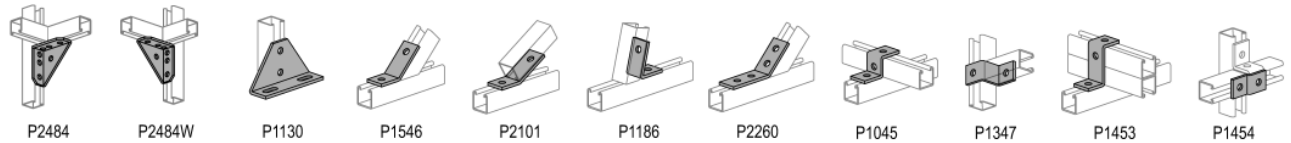

"U" Shape Fittings

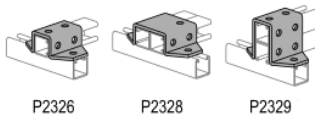
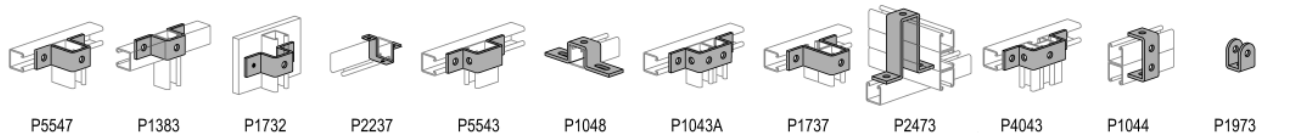
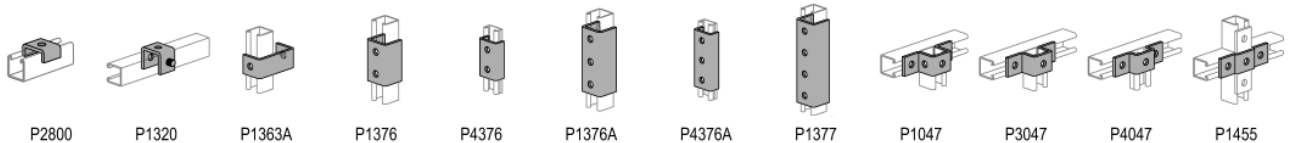

Complete List of Unistrut Fittings Available (continued) (Call for more details)

Wing Shape Fittings

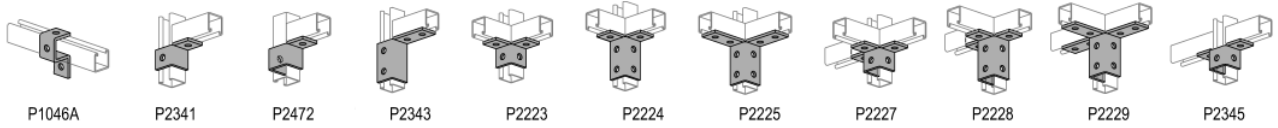

Post Bases



Brackets and Brace Fittings

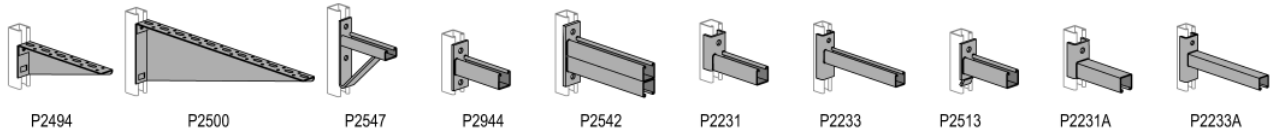

Beam Clamps

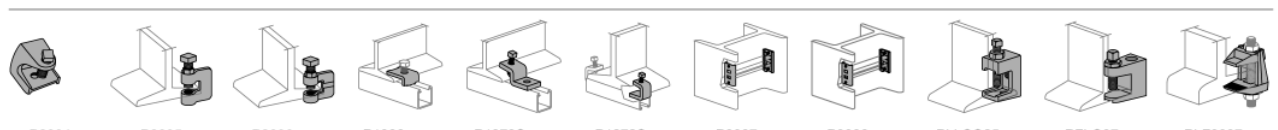
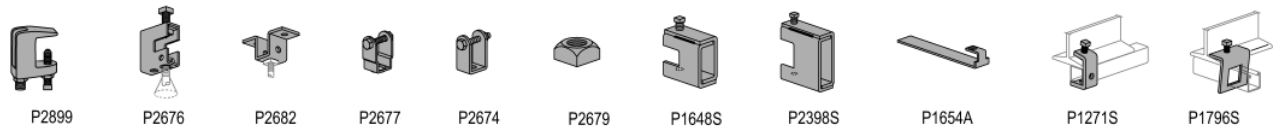
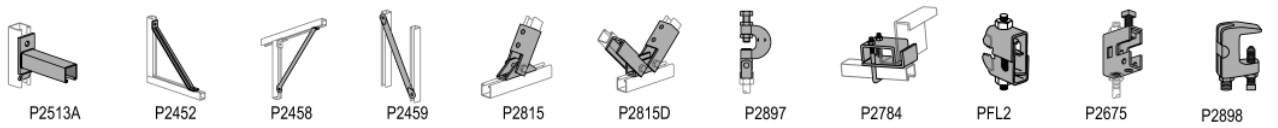

Trolley Assemblies

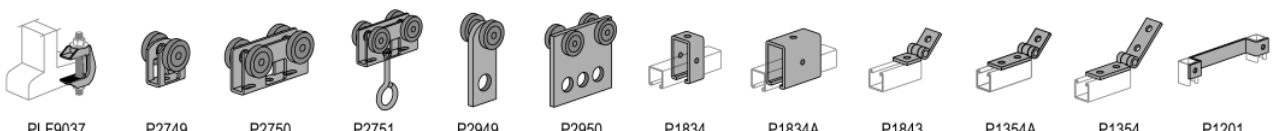

Special Applications Fittings

Seismic Retrofit Fittings

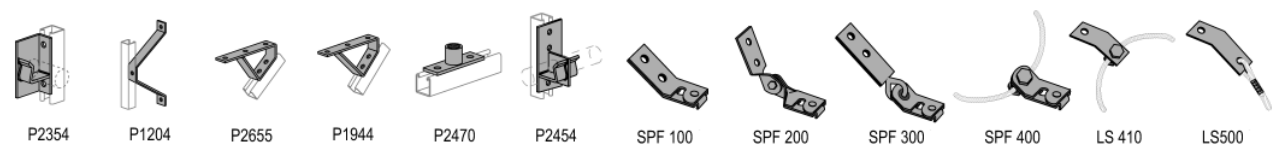



UNISTRUT SEISMIC BRACING SYSTEMS

UNISTRUT Bracing Systems are designed for the resisting of load requirements therefore keeping non-structural components intact and operational. Each Authority having Jurisdiction (AHJ) will address the requirements through their design professional using the Building Code and standards covering the type of structure and location. The pictures below show some of the standard configurations of bracing and the components that can make up the support.

Remember your system if planned ahead can use non-retrofit fittings, but if you are adding your bracing to an existing system retrofit fittings are available (look for the SPF fittings.) The sizing of the anchor, rod and channel members all must be confirmed to qualify the support.

Typical systems support: piping, conduit, cable tray, ducts and equipment.

The State with one of the highest standards of Seismic Bracing requirements is California. The agency controlling systems used in "Essential Facilities," in California is the Office of Statewide Health and Planning

(OSHDP.) They review and approve bracing systems and allow the manufactures to publish an approved OPA (OSHDP Pre-Approved) document which takes you through the design process. UNISTRUT has an OPA-0120 for use in designs through the CBC2007 code. This document is available by going to www.unistrutseismic.com. A newer submittal for the CBC2010 code is in Sacramento awaiting review and approval. This newer document is not yet published but pages can be supplied upon request.

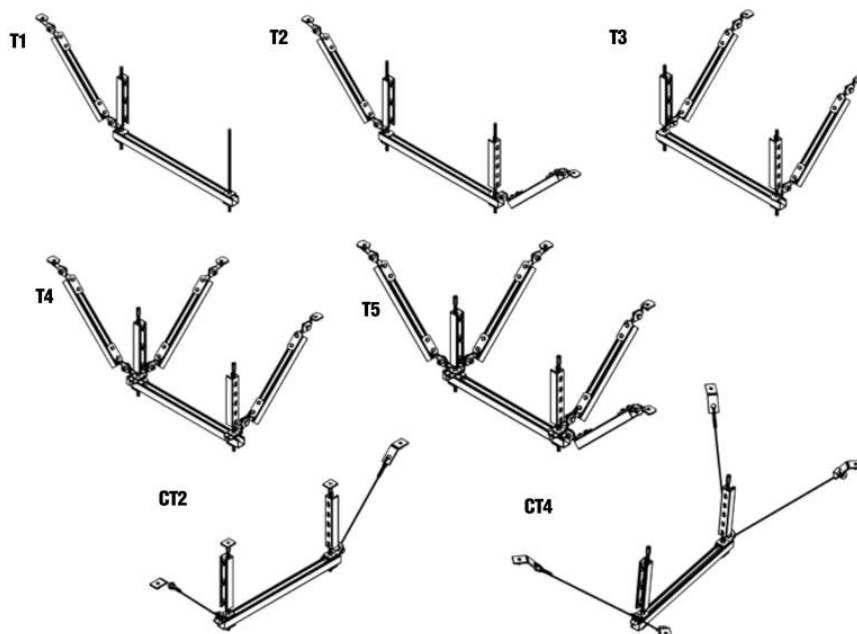
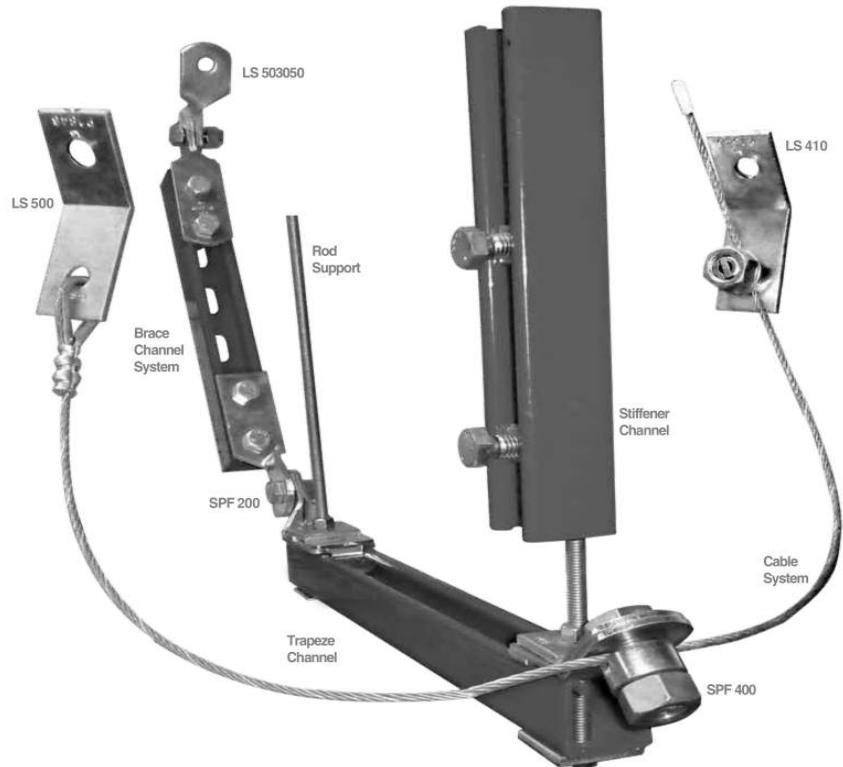

UNISTRUT

A BRAND OF atkore

UNISTRUT 1-5/8" Channel

P1000 Single Solid



- Gauge: 12 (.105")
- Allowable Moment: 5,070 in-lbs
- Wt./100': 189 lbs
- Call to specify material, finish and length

Item #
UTP1000

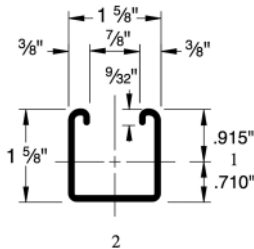

UNISTRUT 1-5/8" Channel

P1000T Single Slotted

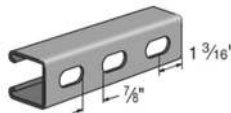

- Gauge: 12 (.105")
- Allowable Moment: 5,070 in-lbs
- Wt./100': 185 lbs
- Call to specify material, finish and length

Item #
UTP1000T

UNISTRUT 1-5/8" Channel

P1000HS Single 1/2 Slot

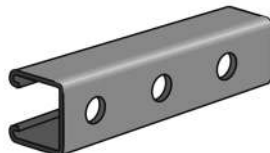

- Gauge: 12 (.105")
- Allowable Moment: 5,070 in-lbs
- Wt./100': 185 lbs
- Slot Size: 9/16" - 1-7/8" O.C.
- Call to specify material, finish and length

Item #
UTP1000HS

UNISTRUT 1-5/8" Channel

P1001 Back to Back Solid

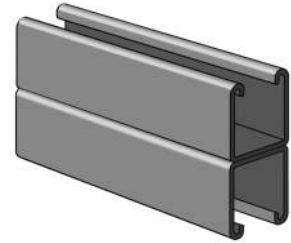

- Gauge: 12 (.105")
- Allowable Moment: 14,360 in-lbs
- Wt./100': 378 lbs
- Call to specify material, finish and length

Item #
UTP1001

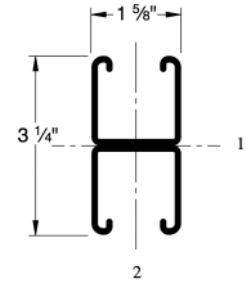

UNISTRUT 1-5/8" Channel

P1001T Back to Back Slotted



- Gauge: 12 (.105")
- Allowable Moment: 14,360 in-lbs
- Wt./100': 321 lbs
- Slot Size: 1-1/8" x 9/16" - 2" O.C.
- Call to specify material, finish and length

Item #
UTP1001T

UNISTRUT 1-5/8" Channel

P3000 Single Solid



- Gauge: 12 (.105")
- Allowable Moment: 3,870 in-lbs
- Wt./100': 170 lbs
- Call to specify material, finish and length

Item #
UTP3000

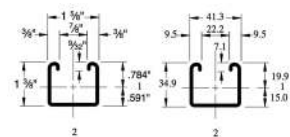

Edge cuts and assembles Unistrut.
Call for more information.



UNISTRUT

A BRAND OF **atkore**

UNISTRUT
1-5/8" Channel

P3000T Single Slotted

- Gauge: 12 (.105")
- Allowable Moment: 3,870 in-lbs
- Wt./100': 165 lbs
- Slot Size: 1-1/8" x 9/16" - 2" O.C.
- Call to specify material, finish and length

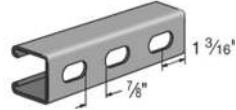

Item #
UTP3000T

UNISTRUT
1-5/8" Channel

P3001 Back to Back Solid

- Gauge: 12 (.105")
- Allowable Moment: 10,810 in-lbs
- Wt./100': 340 lbs
- Call to specify material, finish and length

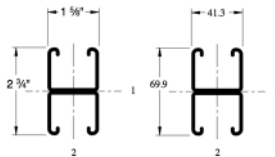
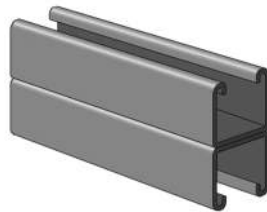

Item #
UTP3001

UNISTRUT
1-5/8" Channel

P3300 Single Solid

- Gauge: 12 (.105")
- Allowable Moment: 1,800 in-lbs
- Wt./100': 134 lbs
- Call to specify material, finish and length

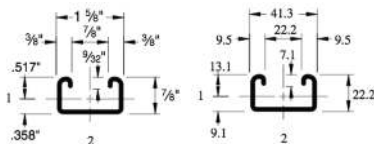

Item #
UTP3300

UNISTRUT
1-5/8" Channel

P3300T Single Slotted

- Gauge: 12 (.105")
- Allowable Moment: 1,800 in-lbs
- Wt./100': 130 lbs
- Slot Size: 1-1/8" x 9/16" - 2" O.C.
- Call to specify material, finish and length

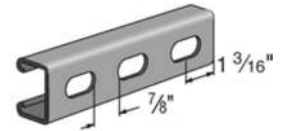

Item #
UTP3300T

UNISTRUT
1-5/8" Channel

P3301 Back to Back Solid

- Gauge: 12 (.105")
- Allowable Moment: 5060 in-lbs
- Wt./100': 269 lbs
- Call to specify material, finish and length

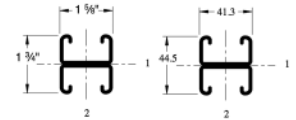

Item # Finish
UTP3301

UNISTRUT
1-5/8" Channel

P4000 Single Solid

- Gauge: 16 (.060")
- Allowable Moment: 1,230 in-lbs
- Wt./100': 83 lbs
- Call to specify material, finish and length

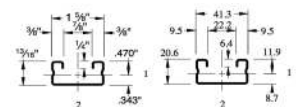

Item #
UTP4000

UNISTRUT
1-5/8" Channel

P4000 T Single Slotted

- Gauge: 16 (.060")
- Allowable Moment: 1,230 in-lbs
- Wt./100': 79 lbs
- Slot Size: 1-1/8" x 9/16" - 2" O.C.
- Call to specify material, finish and length

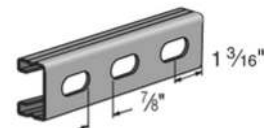

Item #
UTP4000T

UNISTRUT

A BRAND OF **atkore**

UNISTRUT 1-5/8" Channel

P4100 Single Solid

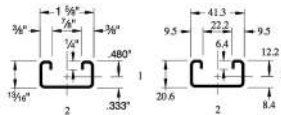

- Gauge: 14 (.075")
- Allowable Moment: 1,360 in-lbs
- Wt./100': 98 lbs
- Call to specify material, finish and length

Item #

UTP4100

UNISTRUT 1-5/8" Channel

P4100T Single Slotted

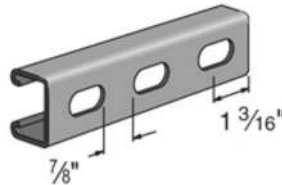

- Gauge: 14 (.075")
- Allowable Moment: 1,360 in-lbs
- Wt./100': 87 lbs
- Slot Size: 1-1/8" x 9/16" - 2" O.C.
- Call to specify material, finish and length

Item #

UTP4100T

UNISTRUT 1-5/8" Channel

P4100T Single Long Slot

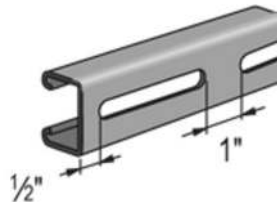

- Gauge: 14 (.075")
- Allowable Moment: 1,360 in-lbs
- Wt./100': 87 lbs
- Slot Size: 3" x 13/32" - 4" O.C.
- Call to specify material, finish and length

Item #

UTP4100SL

UNISTRUT 1-5/8" Channel P5000 Single Solid

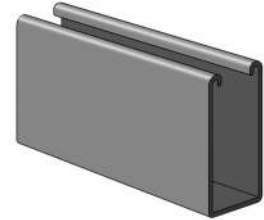

- Gauge: 12 (.105")
- Allowable Moment: 15,770 in-lbs
- Wt./100': 305 lbs
- Call to specify material, finish and length

Item #

UTP5000

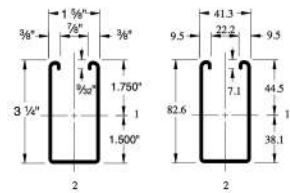

UNISTRUT 1-5/8" Channel

P5000T Single Slotted

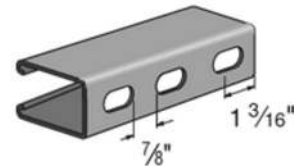

- Gauge: 12 (.105")
- Allowable Moment: 15,770 in-lbs
- Wt./100': 300 lbs
- Slot Size: 1-1/8" x 9/16" - 2" O.C.
- Call to specify material, finish and length

Item #

UTP5000T

UNISTRUT 1-5/8" Channel

P5001 Back to Back Solid

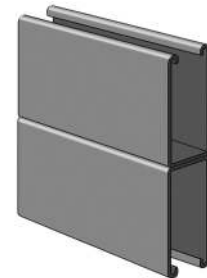

- Gauge: 12 (.105")
- Allowable Moment: 48,180 in-lbs
- Wt./100': 610 lbs
- Call to specify material, finish and length

Item #

UTP5001

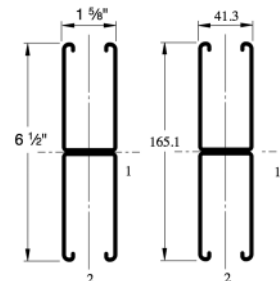



UNISTRUT®

A BRAND OF atkore

UNISTRUT 1-5/8" Channel

P5500 Single Solid

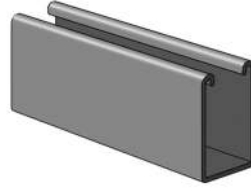

- Gauge: 12 (.105")
- Allowable Moment: 9,820 in-lbs
- Wt./100': 247 lbs
- Call to specify material, finish and length

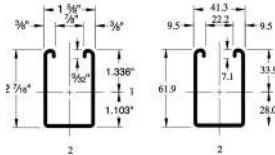

Item #

UTP5500

UNISTRUT 1-5/8" Channel

P5500T Single Slotted

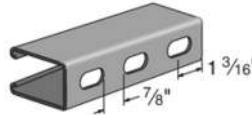

- Gauge: 12 (.105")
- Allowable Moment: 9,820 in-lbs
- Wt./100': 242 lbs
- Slot Size: 1-1/8" x 9/16" - 2" O.C.
- Call to specify material, finish and length

Item #

UTP5500T

UNISTRUT 1-5/8" Channel

P5501 Back to Back Solid

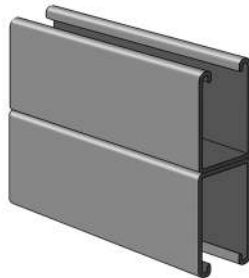

- Gauge: 12 (.105")
- Allowable Moment: 28,940 in-lbs
- Wt./100': 494 lbs
- Call to specify material, finish and length

Item #

UTP5501

UNISTRUT Closure Strip

P3184-Metal



- Standard length: 10'

Item # Finish

UTP3184PG Pre-Galv

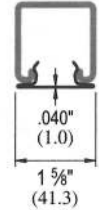

UNISTRUT Closure Strip

P3184F-Metal



- Standard length: 16' (4.9m)

Item # Finish

UTP3184FPG Pre-Galv

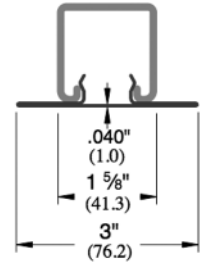

UNISTRUT Closure Strip

P3712P-Plastic



- Color: Black.
- Note: Use with P3170, P3270, and P3370 series concrete insert.
- Standard length: 10' (3m)

Item #

UTP3712P

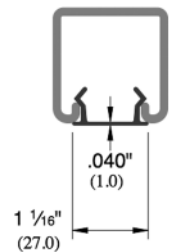

UNISTRUT Plastic White End Cap

P2860-10

- Use with P1000, P1100, P2000 channels & P9000 Telestrut
- Material: Plastic

Item #

UTP2860-10VY

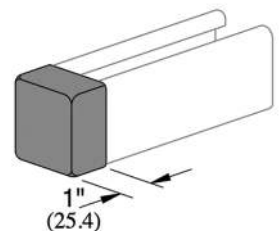

UNISTRUT®

A BRAND OF atkore

UNISTRUT

Plastic White End Cap

P2860-33

- Use with P3300 channel
- Material: Plastic

Item #

P2860-33VY

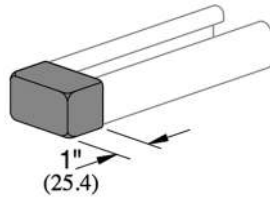

UNISTRUT

Plastic White End Cap

P2860-55

- Use with P5500 channel
- Material: Plastic

Item #

UTP2860-55VY

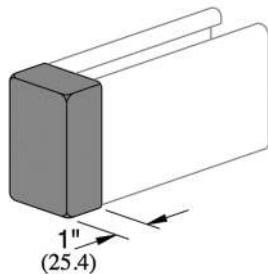

UNISTRUT

Telestrut Tubing

P9000 1-5/8"

- Fits inside P9200
- Same outside dimensions as P1000
- 12 Gauge Nominal Thickness .105" (2.7mm)
- Allowable Moment (in-Lbs): 5,080
- Wt./100': 188 lbs
- Ask about Telestrut post bases, fittings, and pins
- See also: Telespar product
- Call to Specify material, finish and length

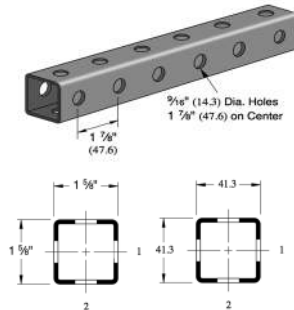

Item #

UTP9000

UNISTRUT

Telestrut Tubing

P9200 1-7/8"

- 12 Gauge Nominal Thickness .105" (2.7mm)
- P1000 and P9000 telescope inside
- Allowable Moment (in-Lbs): 14,390
- Wt./100': 223 lbs
- Ask about Telestrut post bases, fittings, and pins
- See also: Telespar product
- Call to specify material, finish and length

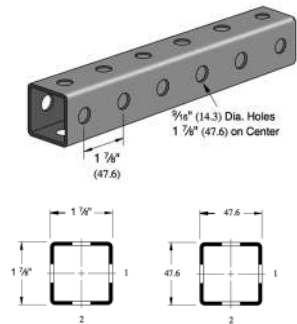

Item #

UTP9200

UNISTRUT

Channel Nut

P10XX With Spring

For use with Channel P1000, P1100, P2000, P3000

- Call to specify material and finish

Item # Nut Size Thread

UTP1006-1420	1/4"-20
UTP1007	5/16"-18
UTP1008	3/8"-16
UTP1009	7/16"-14
UTP1010S	1/2"-13
UTP1012S	5/8"-11
UTP1023S	3/4"-10
UTP1024S	7/8"-9

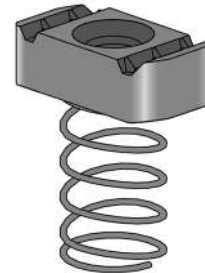

UNISTRUT

Channel Nuts

P40XX With Spring

- For Use with Channel P3300, P4000, P4100
- Call to specify material and finish

Item # Nut Size

UTP4006-1420	1/4" -20
UTP4008	3/8" -16
UTP4010	1/2" -13
UTP4012S	5/8"-11



UNISTRUT

A BRAND OF **atkore**

UNISTRUT
Channel Nut

P5510 With Spring

- For Use with Channel P5500 only
- Call to specify material and finish

Item #	Nut Size
UTP5510	1/2" -13

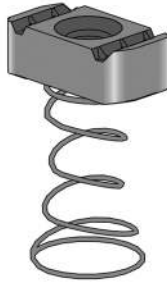

UNISTRUT
Channel Nut

P6006 With Spring

- For Use with Channel P5500 only
- Call to specify material and finish

Item #	Nut Size
UTP6006-0836	#8-36
UTP6006-0832	#8 -32
UTP6006-1032	#10-32
UTP6006-1024	#10-24
UTP6006-1420	1/4"-20



UNISTRUT
Channel Nut

P7006 With Spring

- Call to specify material and finish

Item #	Nut Size
UTP7006-1420	1/4"-20



UNISTRUT
Channel Nut

P30XX Without Spring

- For use with P1000, P1100, P2000, P3000, P3300, P4000, P4100, P5000, and P5500
- Call to specify material and finish

Item #	Nut Size
UTP3006-0832	#8-32
UTP3006-1024	#10-24
UTP3006-1420	1/4"-20
UTP3007	5/16"-18
UTP3008	3/8" -16
UTP3009	7/16"-14
UTP3010	1/2" -13
UTP3013	1/2" -13

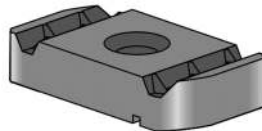

UNISTRUT
Channel Nut

P10XX Without Spring

For use with Channel P1000, P1100, P2000, P3000, P5000, P5500

- Special plastic retaining feature
- Call to specify material and finish

Item #	Nut Size Thread
UTP1006T1420	1/4" -20
UTP1008T	3/8" -16
UTP1010T	1/2" -13
UTP1012	5/8" -11
UTP1023	3/4" -11

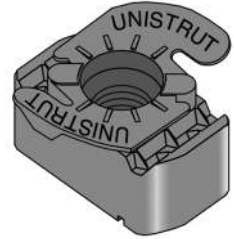

UNISTRUT
Channel Stud Nut

P2380 With Spring

- Nut Size Thread: 3/8" -16
- A Stud Size: 1 1/8"
- B Thread Size: 7/8"
- For Use With: P100, P1100, P2000, P3000
- All stud nut grooves are serrated
- Call to specify material and finish

Item #
UTP2380-2

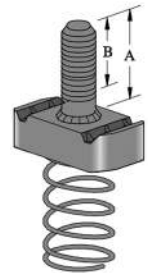

UNISTRUT
Hardware

Hex Nut

- Call to specify material and finish

Item #	Size
UTHHXN037	3/8"
UTHHXN050	1/2"



UNISTRUT
Hardware

Shakeproof Lock Washer

- Call to specify material and finish

Item #	Size
UTHLKW037	3/8"
UTHLKW050	1/2"

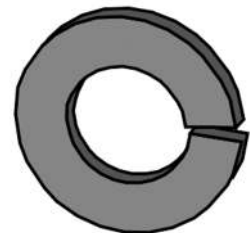

UNISTRUT

A BRAND OF atkore

UNISTRUT Seismic

Cradle Clip

- Call to specify material and finish

Item #

UTP2485

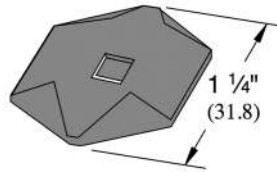

UNISTRUT Flat Plate Fitting

1 Hole Square Washer

- Refer to Standard Dimensions for width, thickness, hole diameters and hole spacing
- Call to specify material and finish

Item #	Bolt Size	Hole Size
UTP1062	5/16"	11/32"
UTP1063	3/8"	7/16"
UTP1064	1/2"	9/16"
UTP1964	5/8"	11/16"
UTP2471	3/4"	15/16"

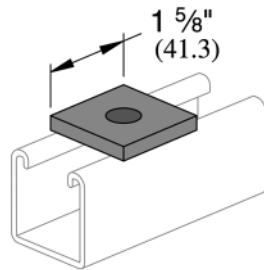

UNISTRUT Flat Plate Fitting

1 Hole Washer Anti-Rotate

- Refer to Standard Dimensions for width, thickness, hole diameters and hole spacing
- Call to specify material and finish

Item #	Bolt Size	Hole Size
UTP2863	3/8"	7/16"
UTP2864	1/2"	1/2"

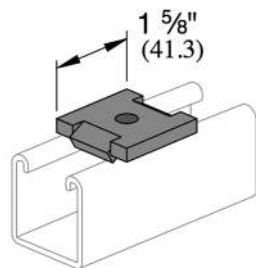

UNISTRUT Flat Plate Fitting

P2324 3 Hole

- Refer to Standard Dimensions for width, thickness, hole diameters and hole spacing
- Call to specify material and finish

Item #

UTP2324

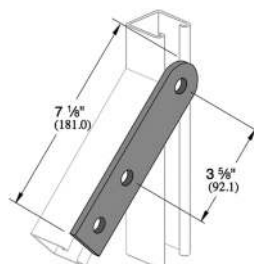

UNISTRUT Flat Plate Fitting

P1065 2 Hole

- Refer to Standard Dimensions for width, thickness, hole diameters and hole spacing
- Call to specify material and finish

Item #

UTP1065

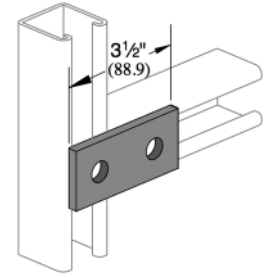

UNISTRUT Flat Plate Fitting

P1066 3 Hole

- Refer to Standard Dimensions for width, thickness, hole diameters and hole spacing
- Call to specify material and finish

Item #

UTP1066

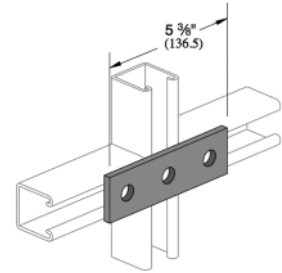

UNISTRUT Flat Plate Fitting

P1067 4 Hole

- Refer to Standard Dimensions for width, thickness, hole diameters and hole spacing
- Call to specify material and finish

Item #

UTP1067

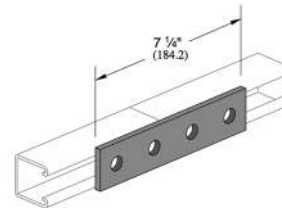

UNISTRUT Flat Plate Fitting

P1941 5 Hole

- Refer to Standard Dimensions for width, thickness, hole diameters and hole spacing
- Call to specify material and finish

Item #

UTP1941

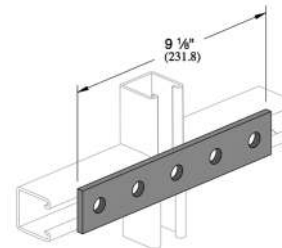

UNISTRUT

A BRAND OF **atkore**

UNISTRUT
Flat Plate Fitting

P1036 3 Hole Corner

- Refer to Standard Dimensions for width, thickness, hole diameters and hole spacing
- Call to specify material and finish

Item #

UTP1036

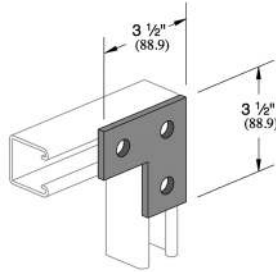

UNISTRUT
Flat Plate L Fitting

P1380A 4 Hole Corner

- Refer to Standard Dimensions for width, thickness, hole diameters and hole spacing
- Call to specify material and finish

Item #

UTP1380A

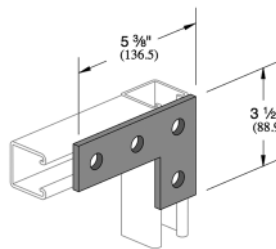

UNISTRUT
Flat Plate Fitting

P1380 4 Hole Corner Gusset

- Refer to Standard Dimensions for width, thickness, hole diameters and hole spacing
- Call to specify material and finish

Item #

UTP1380

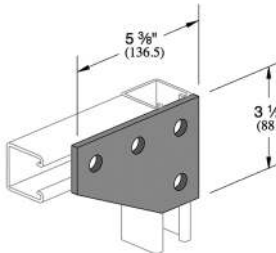

UNISTRUT
Flat Plate Fitting

P1873 5 Hole Corner Gusset

- Refer to Standard Dimensions for width, thickness, hole diameters and hole spacing
- Call to specify material and finish

Item #

UTP1873

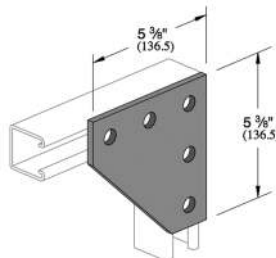

UNISTRUT
Flat Plate Fitting

P1031 4 Hole Tee

- Refer to Standard Dimensions for width, thickness, hole diameters and hole spacing
- Call to specify material and finish

Item #

UTP1031

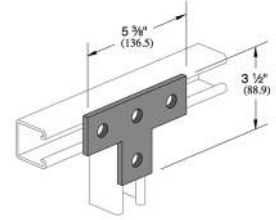

UNISTRUT
Flat Plate Fitting

P1028 5 Hole Cross

- Refer to Standard Dimensions for width, thickness, hole diameters and hole spacing
- Call to specify material and finish

Item #

UTP1028

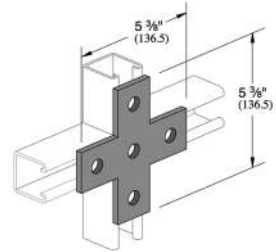

UNISTRUT
Flat Plate Fitting

P1356 3 Hole Gusset Tee

- Refer to Standard Dimensions for width, thickness, hole diameters and hole spacing
- Call to specify material and finish

Item # Finish

UTP1356

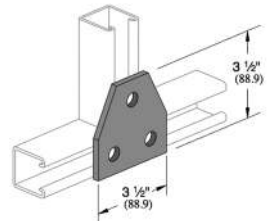

UNISTRUT
Flat Plate Fitting

P1726 5 Hole Gusset Tee

- Refer to Standard Dimensions for width, thickness, hole diameters and hole spacing
- Call to specify material and finish

Item #

UTP1726

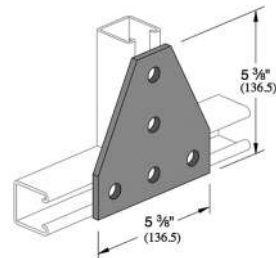

UNISTRUT

A BRAND OF atkore

UNISTRUT

Flat Plate Fitting

P1950 7 Hole Gusset Cross

- Refer to Standard Dimensions for width, thickness, hole diameters and hole spacing
- Call to specify material and finish

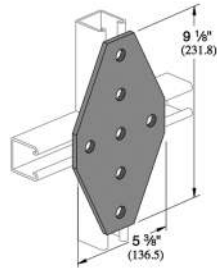

Item #
UTP1950

UNISTRUT

90° Angle Fitting

P2626 2 Hole Anti-Rotate

- Refer to Standard Dimensions for width, thickness, hole diameters and hole spacing
- Call to specify material and finish

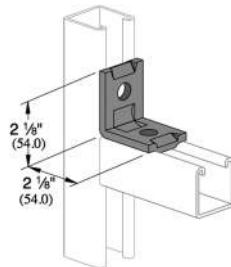

Item #
UTP2626

UNISTRUT

90° Angle Fitting

P1026 2 Hole

- Refer to Standard Dimensions for width, thickness, hole diameters and hole spacing
- Call to specify material and finish

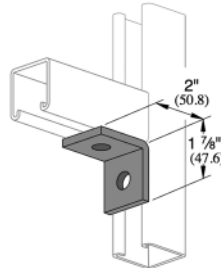

Item #
UTP1026

UNISTRUT

90° Angle Fitting

P1723 2 Hole

- Refer to Standard Dimensions for width, thickness, hole diameters and hole spacing
- Call to specify material and finish

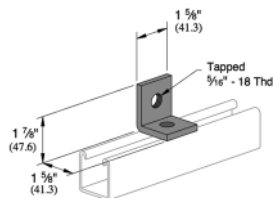

Item #
UTP1723

UNISTRUT

90° Angle Fitting

P1068 2 Hole

- Refer to Standard Dimensions for width, thickness, hole diameters and hole spacing
- Call to specify material and finish

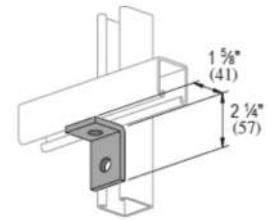

Item #
UTP1068

UNISTRUT

90° Angle Fitting

P1281 2 Hole

- Refer to Standard Dimensions for width, thickness, hole diameters and hole spacing
- Call to specify material and finish

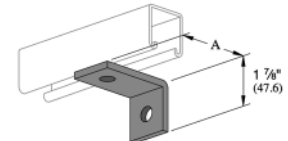

Item #	A
UTP1281	3"

UNISTRUT

90° Angle Fitting

P1458 3 Hole

- Refer to Standard Dimensions for width, thickness, hole diameters and hole spacing
- Call to specify material and finish

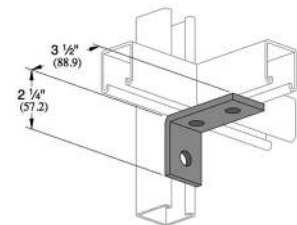

Item #
UTP1458

UNISTRUT

90° Angle Fitting

P1499 1 Hole & 1 Slot

- Refer to Standard Dimensions for width, thickness, hole diameters and hole spacing
- Call to specify material and finish

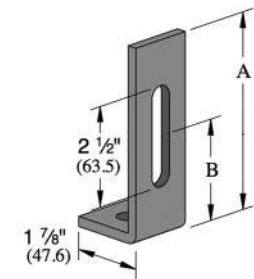

Item #	A	B
UTP1499	6 7/8"	4 1/2"

UNISTRUT

90° Angle Fitting

P1326 3 Hole

- Refer to Standard Dimensions for width, thickness, hole diameters and hole spacing
- Call to specify material and finish

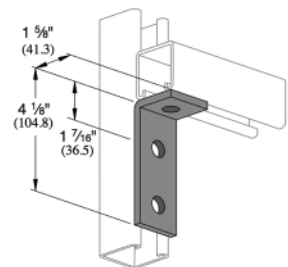

Item #
UTP1326



UNISTRUT

A BRAND OF atkore

UNISTRUT 90° Angle Fitting

P1346 3 Hole

- Refer to Standard Dimensions for width, thickness, hole diameters and hole spacing
- Call to specify material and finish

Item #

UTP1346

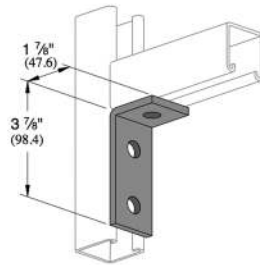

UNISTRUT 90° Angle Fitting

P1325 4 Hole

- Refer to Standard Dimensions for width, thickness, hole diameters and hole spacing
- Call to specify material and finish

Item #

UTP1325

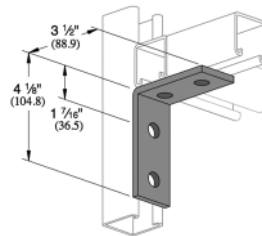

UNISTRUT 90° Angle Fitting

P1382 4 Hole Gusset

- Refer to Standard Dimensions for width, thickness, hole diameters and hole spacing
- Call to specify material and finish

Item #

UTP1382

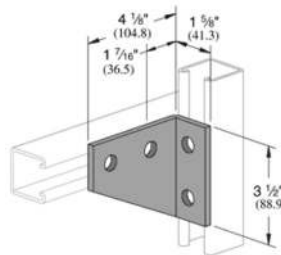

UNISTRUT 90° Angle Fitting

P2235 5 Hole Gusset

- Refer to Standard Dimensions for width, thickness, hole diameters and hole spacing
- Call to specify material and finish

Item #

UTP2235

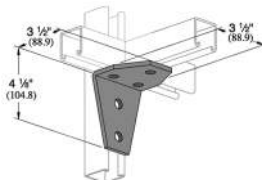

UNISTRUT 90° Fitting

P2484 7 Hole Gusset

- Refer to Standard Dimensions for width, thickness, hole diameters and hole spacing
- Call to specify material and finish

Item #

UTP2484

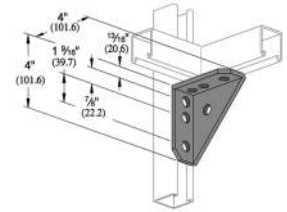

UNISTRUT 90° Fitting

P2484W 7 Hole Gusset

- Welded Corner
- Refer to Standard Dimensions for width, thickness, hole diameters and hole spacing
- Call to specify material and finish

Item #

UTP2484W

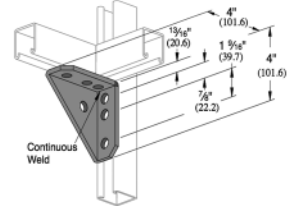

UNISTRUT Angle Fitting

2 Hole

- Refer to Standard Dimensions for width, thickness, hole diameters and hole spacing
- Call to specify material and finish

Item # 'A' Degree 'B' Size 'C' Size

UTP1546	45°	3"	2 5/16"
UTP2097	60°	3 3/8"	1 7/8"
UTP2098	52 1/2°	3 1/4"	2 1/16"
UTP2099	37 1/2°	2 1/16"	2 5/8"

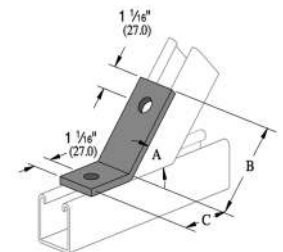

UNISTRUT Angle Fitting

2 Hole

- Ask about other angles
- Refer to Standard Dimensions for width, thickness, hole diameters and hole spacing
- Call to specify material and finish

Item #

A B

UTP2101 30° 3 1/4"

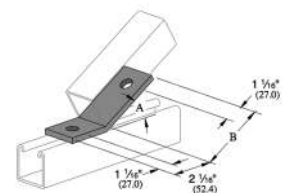

UNISTRUT

A BRAND OF atkore

UNISTRUT Angle Fitting

2 Hole

- Ask about other angles
- Refer to Standard Dimensions for width, thickness, hole diameters and hole spacing
- Call to specify material and finish

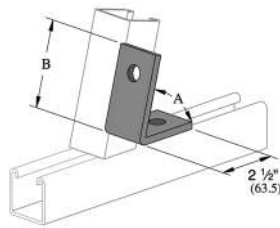

Item #
UTP1186

UNISTRUT Angle Fittings

4 Hole

- Ask about other angles
- Refer to Standard Dimensions for width, thickness, hole diameters and hole spacing
- Call to specify material and finish

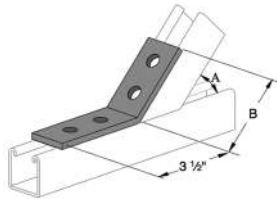

Item #
UTP2265

UNISTRUT Z Shape Fitting

P1045

- Refer to Standard Dimensions for width, thickness, hole diameters and hole spacing
- Call to specify material and finish

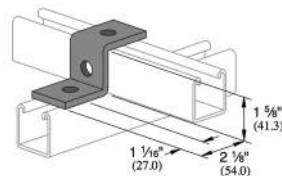

Item #
UTP1045

UNISTRUT Z Shape Fitting

P5560

- For use with P5500
- Refer to Standard Dimensions for width, thickness, hole diameters and hole spacing
- Call to specify material and finish

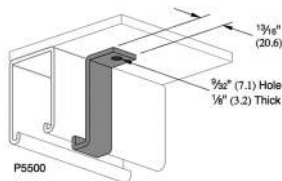

Item #
UTP5560

UNISTRUT Z Shape Fitting

P3045 2 Hole

- Refer to Standard Dimensions for width, thickness, hole diameters and hole spacing
- Call to specify material and finish

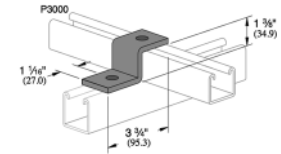

Item #
UTP3045

UNISTRUT Z Shape Fitting

P4045 2 Hole

- Refer to Standard Dimensions for width, thickness, hole diameters and hole spacing
- Call to specify material and finish

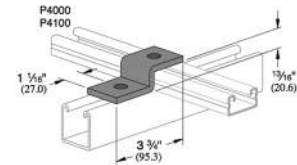

Item #
UTP4045

UNISTRUT U Shape Fitting

P1376A 3 Hole Splice

- Refer to Standard Dimensions for width, thickness, hole diameters and hole spacing
- Call to specify material and finish

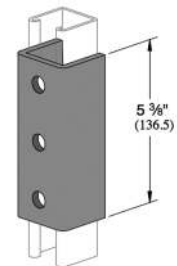

Item #
UTP1376A

UNISTRUT U Shape Fitting

P1377 4 Hole Splice

- For use with P100, P1100, P2000
- Refer to Standard Dimensions for width, thickness, hole diameters and hole spacing
- Call to specify material and finish

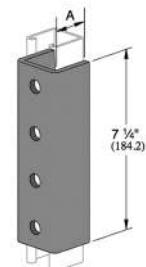

Item #
UTP1377

UNISTRUT Hat Shape Fitting

P1047 5 Hole

- For use with P1000
- Refer to Standard Dimensions for width, thickness, hole diameters and hole spacing
- Call to specify material and finish

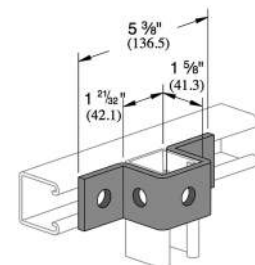

Item #
UTP1047



UNISTRUT®

A BRAND OF atkore

UNISTRUT Hat Shape Fitting

P1048 Slots

- For use with P1000
- Refer to Standard Dimensions for width, thickness, hole diameters and hole spacing
- Call to specify material and thickness

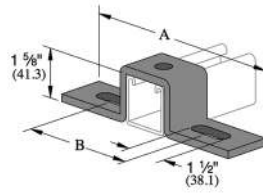

Item #

UTP1048

UNISTRUT Hat Shape Fitting

P1043 6 Hole

- For use with P1001
- Refer to Standard Dimensions for width, thickness, hole diameters and hole spacing
- Call to specify material and finish

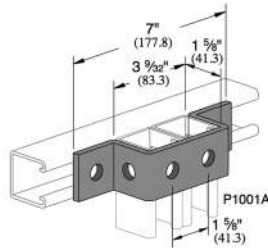

Item #

UTP1043A

UNISTRUT Hat Shape Fitting

P1737 3 Hole

- For use with P1001
- Refer to Standard Dimensions for width, thickness, hole diameters and hole spacing
- Call to specify material and finish

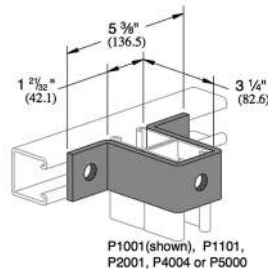

Item #

UTP1737

UNISTRUT Hat Shape Fitting

P2473 3 Hole

- For use with P5501
- Refer to Standard Dimensions for width, thickness, hole diameters and hole spacing
- Call to specify material and finish

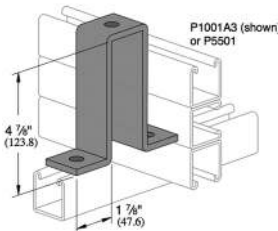

Item #

UTP2473

UNISTRUT Wing Shape Fitting

P2223 4 Hole

- Refer to Standard Dimensions for width, thickness, hole diameters and hole spacing
- Call to specify material and finish

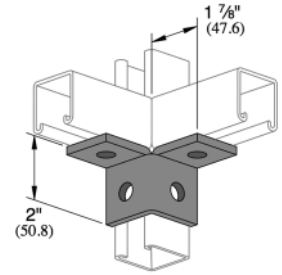

Item #

UTP2223

UNISTRUT Wing Shape Fitting

P2225 8 Hole

- Refer to Standard Dimensions for width, thickness, hole diameters and hole spacing
- Call to specify material and finish

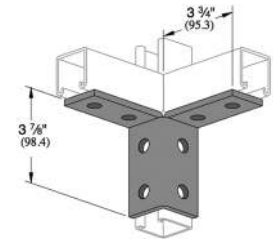

Item #

UTP2225

UNISTRUT Wing Shape Fitting

P 2346 8 Hole

- Refer to Standard Dimensions for width, thickness, hole diameters and hole spacing
- Call to specify material and finish

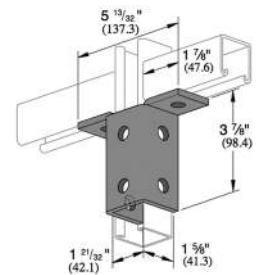

Item #

UTP2346

UNISTRUT Post Base

P2942

- Refer to Standard Dimensions for width, thickness, hole diameters and hole spacing
- Call to specify material and finish

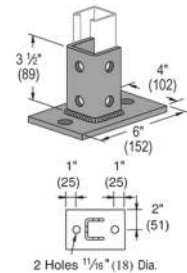

Item #

UTP2942

UNISTRUT

A BRAND OF atkore

UNISTRUT Post Base

P2072XX

- Refer to Standard Dimensions for width, thickness, hole diameters and hole spacing
- Call to specify material and finish

Item #

Angled Base

UTP2072

Square Base

UTP2072SQ

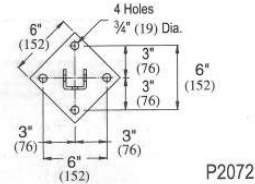
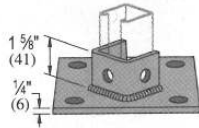

P2072

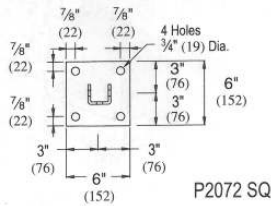

P2072 SQ

UNISTRUT Poast Base

P2072AXX

- Refer to Standard Dimensions for width, thickness, hole diameters and hole spacing
- Call to specify material and finish

Item #

Angled Base

UTP2072A

Square Base

UTP2072ASQ

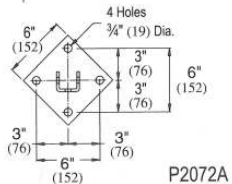
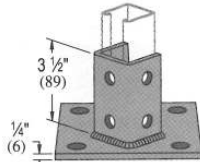

P2072A

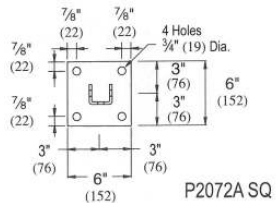

P2072A SQ

UNISTRUT Post Base

P2073A & P2073ASQ

SQ indicates opening square

- Refer to Standard Dimensions for width, thickness, hole diameters and hole spacing
- Call to specify material and finish

Item #

UTP2073A

Square Base

UTP2073ASQ

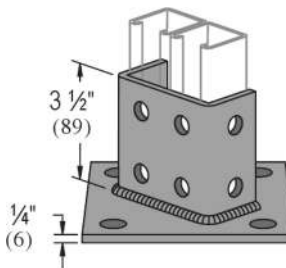

UNISTRUT Brackets

P1771 Heavy Duty

- Material: 1/4" (6.4) Thick Steel
- Call to specify material and finish

Item #

UTP1771

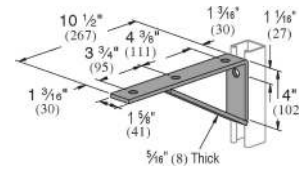

UNISTRUT Brackets

P1773 Heavy Duty

- Material: 1/4" (6.4) Thick Steel
- Call to specify material and finish

Item #

UTP1773

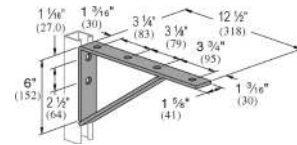

UNISTRUT Brackets

P1775 Heavy Duty

- Material: 1/4" (6.4) Thick Steel
- Call to specify material and finish

Item #

UTP1775

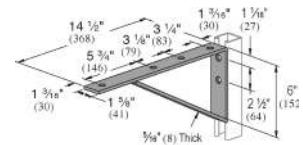

UNISTRUT Brackets

P1777 Heavy Duty

- Material: 1/4" (6.4) Thick Steel
- Call to specify material and finish

Item #

UTP1777

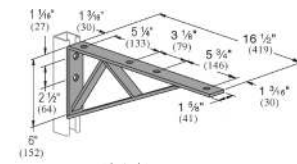

UNISTRUT Brackets

P1075

- Use for P1000, P1100, P2000, P4001 Channels
- Safety Factor: 2-1/2"
- Material: 1/4" thick steel
- Allowable Moment for fitting only. Channel may determine overall capacity
- Call to specify material and finish

Item #

UTP1075

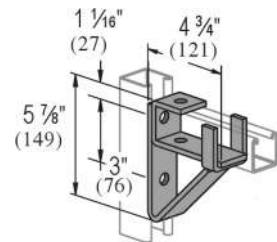



UNISTRUT

A BRAND OF atkore

UNISTRUT Brackets

P294X Slot Up

- Safety Factor 2½"
- Mounted on 12 ga. channel
- Call to specify material, finish and length

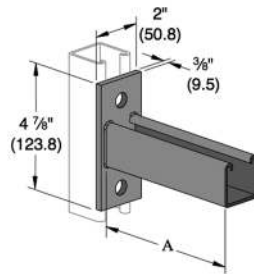

Item #	A Size	Uniform Load (lbs.)
UTP2946	18"	400
UTP2947	24"	300

UNISTRUT Brace fittings

P2815 Adjustable

- 30° Minimum adjustment
- Call to specify material and finish

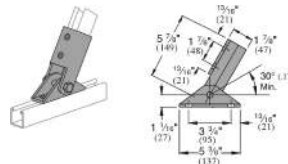

Item #
UTP2815

UNISTRUT Brace Fittings

P2815D Adjustable

- 30° Minimum adjustment
- Call to specify material and finish

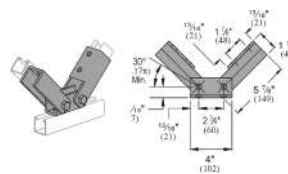

Item #
UTP2815D

UNISTRUT Brace Fittings

P2458-XX Knee Braces

Design Loads:

- Compression: 1500 Lbs. (6.67 kN)
- Tension: 300 Lbs. (1.33kN)
- Call to specify material, finish and length

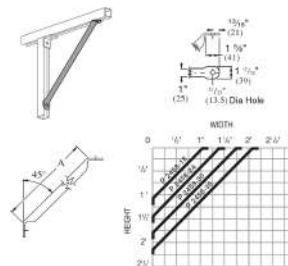

Item #
UTP2458

UNISTRUT Beam Clamp

P2675

- Clamp Materials: .105" (2.7) thick steel.
- Clamp P2675 is designed for light duty rod suspension.
- It also may be used with P3016-1024 or P3016-1420 nut as illustrated above for mounting insulators, etc.
- Call to specify material and finish

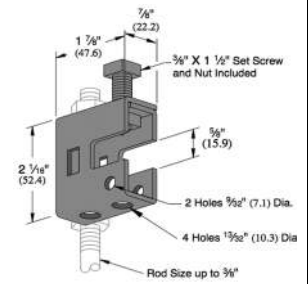

Item #
UTP2675

UNISTRUT Beam Clamp

P16XX

- Size A: 5/8"-11
- Size B: 1/4"
- Size C: 1/2" x 1-1/2"
- Size D: 15/16"
- Design Load: 1,600 lbs.
- Call to specify material and finish

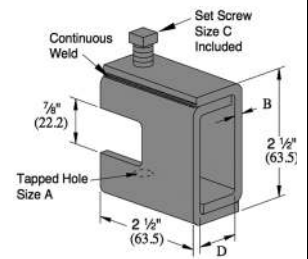

Item #
UTP1651AS

UNISTRUT Beam Clamp Straps

P1657A Retainer Strap

- For beams under 7/8" thick flange
- Flange Width: 9"
- 12 Gage
- Size A: 12"
- Used With Beam Clamp: P1651 AS
- Call to specify material and finish

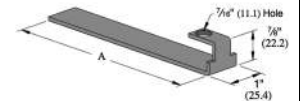

Item #
UTP1657A

UNISTRUT Beam Clamp

P1796S

- Use in pairs only
- 1/2" - 13 x 1 1/2" Set screw included
- Call to specify material and finish

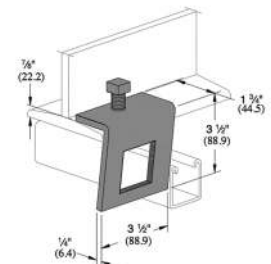

Item #
UTP1796S

UNISTRUT

A BRAND OF atkore

UNISTRUT Beam Clamp

P2785

- For use with Beams up to 3/4" (19.1)
- Flanges and with Channels P1000, P1100, P2000, P3000, P3300, P3301, P4000, P4001, P4100, and P4101
- Use in pairs only
- Call to specify material and finish

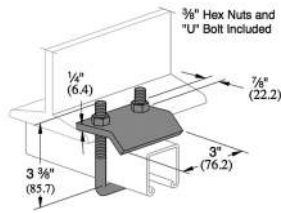

Item #	Design Load (Lbs)
UTP2785	1,000

UNISTRUT Beam Clamp

P2786

- For use with Beams up to 3/4" (19.1)
- Flanges and with channels P1001, P1101, P2001, P3001, P5000, and P5500
- Use in pairs only
- Call to specify material and finish

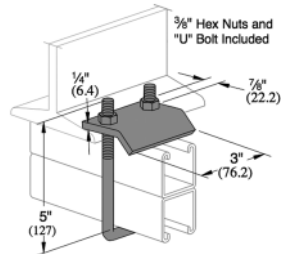

Item #	Design Load (Lbs)
UTP2786	1,000

UNISTRUT Beam Clamp

P2787

- For use with Beams up to 3/4" (19.1)
- Flanges and with Channels P5001 and P5501
- Use in pairs only
- Call to specify material and finish

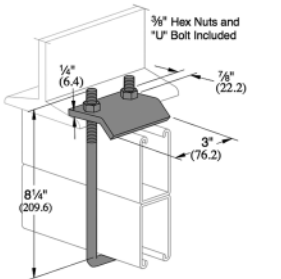

Item #	Design Load (Lbs)
UTP2787	1,000

UNISTRUT Beam Clamp

P2868

- Beam Size A: 4" - 6"
- Includes: Center Rod, "U" Bolts and Hex Nuts
- For use with Channels P1000, P1100, P2000, P3000, P3300, P3301, P4000, P4001, P4100, and P4101
- Call to specify material and finish

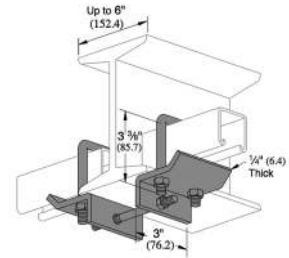

Item #
UTP2868

UNISTRUT Beam Clamp

P289X

- Material: Malleable Iron
- 7/8" Maximum Flange Thickness
- Call to specify material and finish

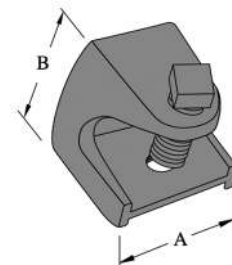

Item #	Rod Size	'A' Size	'B' Size	Load Rating (lbs.)
UTP2894-37	3/8"	2"	2"	350
UTP2894-50	1/2"	2 5/8"	2 1/2"	400

UNISTRUT Beam Clamp

P1386

- Clamp Requires 1/2"-13 x 1 1/2" Hex Head Cap Screw and 1/2" Channel Nut Not Included
- Call to specify material and finish

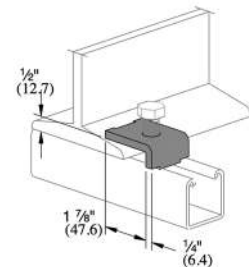

Item #
UTP1386

UNISTRUT Beam Clamp

P1379S

- 1/2" - 13 x 1 1/2" Set Screw Included
- Clamp Requires 1/2" x 1 3/16" Hex Head Cap Screw and 1/2" Channel Nut Not Included
- Call to specify material and finish

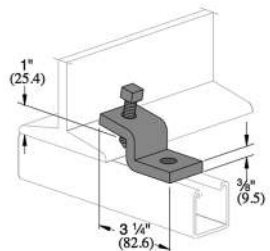

Item #
UTP1379S



UNISTRUT

A BRAND OF **atkore**

UNISTRUT
Beam Clamp

C Shape

- Call to specify material and finish

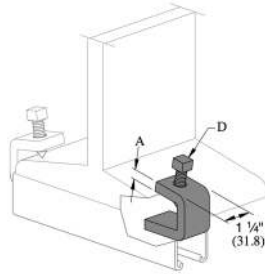

Item #	A	Flange Thick	D Set Screw Included	Design Load
UTP1272S	1/4"	Up to 3/4"	3/8"-16 x 1 1/2"	450
UTP1985S	3/8"	Up to 3/4"	1/2"-13 x 1 1/2"	1,000
UTP1986S	3/8"	7/8" to 2"	1/2"-13 x 1 1/2"	900

UNISTRUT
Trolley

P2749 2 Wheel

- Clevis Material: 12 gauge.
- Wheel bearings are stainless steel, and should not be lubricated.
- Ask about acetal wheels
- Call to specify material and finish

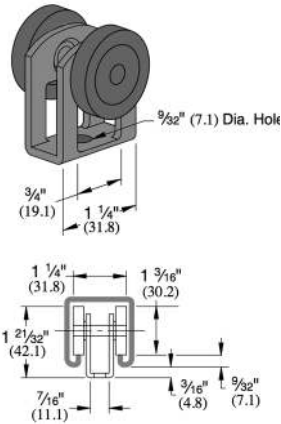

Item #	Design Load (Lbs)
UTP2749	50

UNISTRUT
Trolley

P2750 4 Wheel

- Wheel bearings are stainless steel, and should not be lubricated.
- Ask about acetal wheels
- Call to specify material and finish

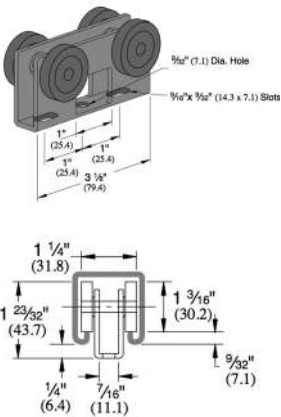

Item #	Design Load (Lbs)
UTP2750	100

UNISTRUT
Loop Trolley

P2751 4 Wheel With Hanger

- Clevis Material: 12 gauge.
- Wheel bearings are stainless steel, and should not be lubricated.
- Ask about acetal wheels
- Call to specify material and finish

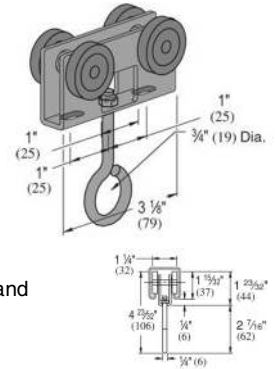

Item #	Design Load (Lbs)
UTP2751	100

UNISTRUT
Trolley

P2950 3 Hole Plate

- Wheel bearings are stainless steel, and should not be lubricated.
- Call to specify material and finish

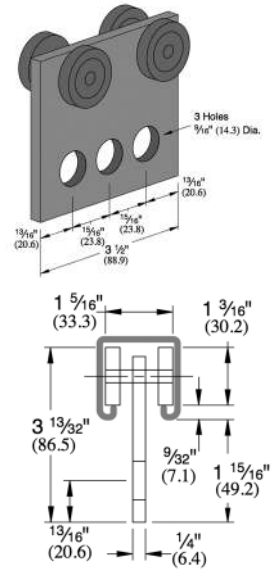

Item #
UTP2950

UNISTRUT

Adjustable Hinge Fitting

P1843 2 Hole Hinge

- Refer to Standard Dimensions for width, thickness, hole diameters and hole spacing
- Call to specify material and finish

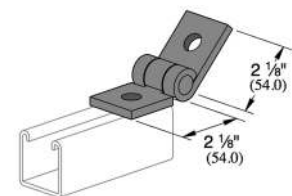

Item #
UTP1843

UNISTRUT

A BRAND OF atkore

UNISTRUT Hinge Fitting

P1354 4 Hole Hinge

- Refer to Standard Dimensions for width, thickness, hole diameters and hole spacing
- Call to specify material and finish

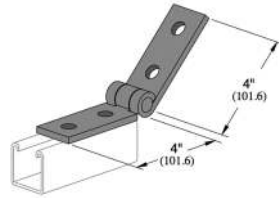

Item #

UTP1354

UNISTRUT

Seismic Fittings

Seismic Cable Fittings

- Call to specify different lengths

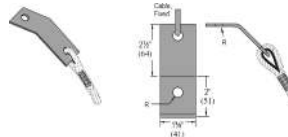

Item #	Hole Diameter in. (mm)	Length (ft.)	Finish
UTLS500-050-120	3/16 (11)	12	Elec-Galv

UNISTRUT

Seismic Fittings

Seismic Cable Fittings

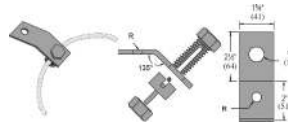

Item #	Hole Diameter Size in. (mm)	Finish
UTLS410-050	3/16 (14)	Elec-Galv

Call Edge for help with your seismic bracing.

UNISTRUT Pipe/Conduit Clamps

P11XX

- Slotted hex head screw and nut included
- For Rigid steel conduit and O.D. pipe
- Call to specify material and finish

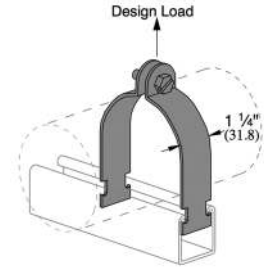

Item #	Pipe Size	O.D. Size	Thickness (ga.)	Design Load
UTP1111	1/2"	0.840"	16	400
UTP1112	3/4"	1.050"	14	600
UTP1113	1"	1.315"	14	600
UTP1114	1 1/4"	1.660"	14	600
UTP1115	1 1/2"	1.900"	12	800
UTP1117	2"	2.375"	12	800
UTP1118	2 1/2"	2.875"	12	800
UTP1119	3"	3.500"	12	800
UTP1120	3 1/2"	4.000"	11	1,000
UTP1121	4"	4.500"	11	1,000
UTP1123	5"	5.563"	11	1,000
UTP1124	6"	6.625"	10	1,000
UTP1126	8"	8.625"	10	1,000

UNISTRUT Pipe/Conduit Clamps

P14XX

- Slotted hex head screw and nut included
- For Thin Wall conduit (EMT)
- Call to specify material and finish

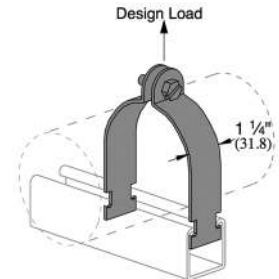

Item #	Pipe Size	O.D. Size	Thickness (ga.)	Design Load
UTP1426	3/8"	0.577"	16	400
UTP1427	1/2"	0.706"	16	400
UTP1428	1"	1.163"	14	600
UTP1429	1 1/4"	1.510"	14	600
UTP1430	1 1/2"	1.710"	12	800
UTP1431	2"	2.197"	12	800



UNISTRUT

A BRAND OF **atkore**

UNISTRUT
Pipe Clamp

P12XX

- Use with Rigid or EMT
- Slotted hex head screw and nut included
- Universal style
- Call to specify material and finish

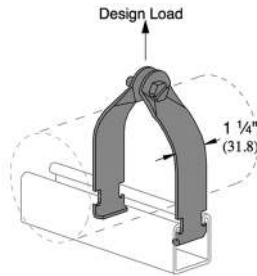

Item #	Pipe Size	Thickness (ga.)	Design Load
UTP1211	1/2"	16	400
UTP1212	3/4"	16	400
UTP1213	1"	16	400
UTP1214	1 1/4"	14	600
UTP1215	1 1/2"	14	600
UTP1217	2"	14	600

UNISTRUT
Tubing Clamps

One Hole Clamp

- 1/4" x 3/4" Round head machine screw and Channel nut not included
- Call to specify material and finish

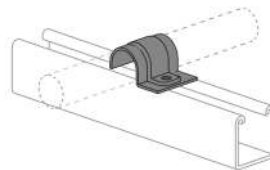

Item #	O.D. Tube Size	Thickness (ga.)
UTP2009	1/4"	16
UTP2010	5/16"	16
UTP2020	1"	14

UNISTRUT
Pipe Clamps

P20XX

- Slotted hex head screw and nut included
- For O.D. tubing
- Call to specify material and finish

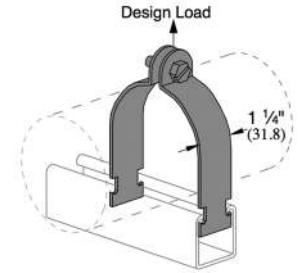

Item #	O.D. Tube Size	Thickness (ga.)	Design Load
UTP2024	1/4"	16	400
UTP2025	3/8"	16	400
UTP2026	1/2"	16	400
UTP2027	5/8"	16	400
UTP2028	3/4"	16	400
UTP2029	7/8"	16	400
UTP2030	1"	14	600
UTP2031	1 1/8"	14	600
UTP2032	1 1/4"	14	600
UTP2033	1 3/8"	14	600
UTP2034	1 1/2"	14	600
UTP2035	1 5/8"	14	600
UTP2037	1 7/8"	12	800
UTP2038	2"	12	800
UTP2039	2 1/8"	12	800
UTP2042	2 1/2"	12	800
UTP2046	3"	12	800
UTP2047	3 1/8"	12	800
UTP2049	3 3/8"	12	800
UTP2051	3 5/8"	12	1,000
UTP2053	3 7/8"	11	1,000
UTP2070	6"	10	1,000
UTP2070-82	8 1/4"	10	1,000

UNISTRUT
Pipe Straps

P2558-XX

- Call to specify material and finish

Item #	Nominal Pipe Size	'A' Size	'B' Size	'C' Size	Thickness	Design Load (lbs.)
UTP2558-05	1/2"	2 7/8"	9/32"	7/16"	1/8"	500
UTP2558-07	3/4"	3 1/8"	9/32"	7/16"	1/8"	500
UTP2558-10	1"	3 3/8"	9/32"	7/16"	1/8"	500
UTP2558-12	1 1/4"	3 3/4"	9/32"	7/16"	1/8"	500
UTP2558-15	1 1/2"	3 7/8"	9/32"	7/16"	1/8"	500
UTP2558-20	2"	5 3/4"	7/16"	1 1/16"	1/4"	1,000
UTP2558-25	2 1/2"	6 1/4"	7/16"	1 1/16"	1/4"	1,000
UTP2558-30	3"	6 7/8"	7/16"	1 1/16"	1/4"	1,000

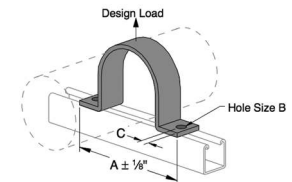

UNISTRUT

... a brand of Atkore

UNISTRUT Insulated Pipe Clamps

Cush-A-Clamp®

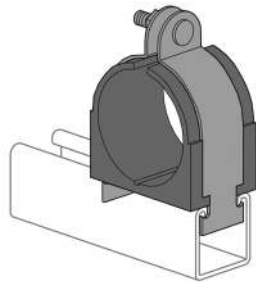

- T - With controlled squeeze shoulder bolt
- N - With standard bolt
- All tube series above 1 1/4" are furnished without the controlled-squeeze shoulder bolt; these sizes feature a threaded stud securely fastened to one clamp half
- Tube O.D. is Cushion I.D. All parts are marked for easy identification and packaged for small lot or bulk use
- Call to specify material and finish

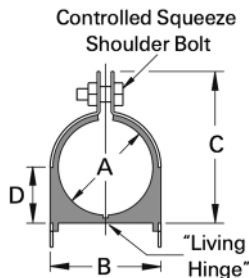

Item #	Tubing O.D.	Pipe Nom.	Dim A	Dim B	Dim C	Dim D
--------	-------------	-----------	-------	-------	-------	-------

Tube Series

UT010T014	5/8"	1/2"	0.62"	1.06"	1.54"	0.46"
UT014T018	7/8"	3/4"	0.87"	1.31"	1.82"	0.58"
UT018T022	1 1/8"	1"	1.12"	1.57"	2.08"	0.70"
UT024N028	1 1/2"	1 1/4"	1.50"	1.95"	2.47"	0.90"
UT026N030	1 5/8"	1 1/2"	1.62"	2.07"	2.60"	0.96"

Pipe Series

UT017N022	-	3/4"	1.05"	1.50"	1.95"	0.70"
-----------	---	------	-------	-------	-------	-------

UNISTRUT Pipe Supports

Unicushion®

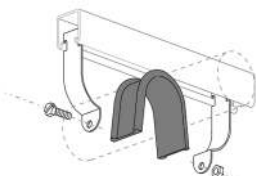
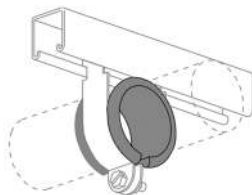

- Shock absorption
- Protection from corrosion and abrasion
- Allowance for expansion and contraction
- Sound and vibration isolation
- Stability in use from - 50° F (- 47° C) to + 350° F (+177° C)
- Flexible elastomer material
- Will not support combustion
- 25 feet per carton

Item #
UTP2600

UNISTRUT Pipe Roller

P2475 For 6" - 16" Pipe

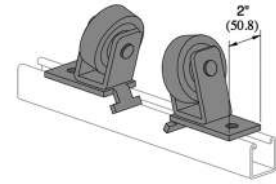

- Requires 2 each 1/2" x 15/16" bolts and 1/2" channel nuts per assembly; sold separately
- Design Load: 1500 lbs.
- Material: Cast iron rollers
- Call to specify material and finish

Pipe Size In	No Insulation In (mm)	Insulation Thickness					
		1" In (mm)	1 1/2" In (mm)	2" In (mm)	2 1/2" In (mm)	3" In (mm)	4" In (mm)
6	9 1/2 241.3	10 1/4 260.4	10 1/2 266.7	10 3/4 273.1	11 279.4	11 1/2 288.9	11 3/4 301.6
8	10 1/2 257.2	* 266.7	11 279.4	11 1/2 288.9	11 3/4 298.5	12 304.8	12 1/2 317.5
10	10 3/4 273.1	* 295.3	11 1/2 295.3	12 304.8	12 1/2 311.2	12 3/4 317.5	13 330.2
12	11 1/4 285.8	* 308.0	12 1/2 308.0	12 3/4 317.5	13 323.9	13 1/2 330.2	14 342.9
14	11 3/4 295.3	* 317.5	12 3/4 317.5	13 327.0	13 1/2 330.2	14 339.7	14 1/2 355.6
16	12 1/2 308.0	* 330.2	13 330.2	13 1/2 339.7	14 352.4	14 1/2 355.6	15 368.3

Item #	Design Load (Lbs)
UTP2475	1500

UNISTRUT Electrical Fittings

Conduit Hanger Connector

- For 1/2" conduit
- 1/4" x 5/8" Flat head machine screw and P3016-1420 nut included
- Material: 12 gauge
- Use with channels: P1000 and P1100
- Call to specify material and finish

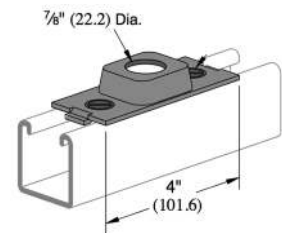

Item #	Design Load (Lbs)
UTP2535	400

UNISTRUT Electrical Fittings

Conduit Hanger Connector

- For 3/4" conduit
- 1/4" x 5/8" Flat head machine screw and P3016-1420 nut included
- Call to specify material and finish

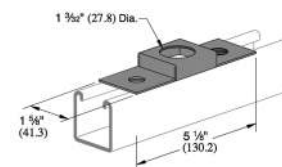

Item #	Design Load (Lbs)
UTP2536	200



UNISTRUT

A BRAND OF **atkore**

UNISTRUT
Electrical Fittings

Channel End Connector

- For 1/2" Conduit
- 1/4" x 5/8" Flat head machine screw and P3016-1420 nut included
- Material: 12 gauge
- Use with channels: P1000 and P1100
- Call to specify material and finish

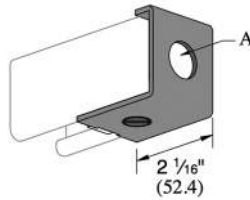

Item #

UTP2521-50

UNISTRUT
Electrical Fittings

Wireway End Cap

- Call to specify material and finish



Item #	Use With
UTP1280W	P1000
UTP4280W	P4000

UNISTRUT
Electrical Fittings

Channel Wiring Stud Nut

- 1/2" American standard straight pipe thread
- A Stud Size: 1-5/64"
- Material: Sintered metal
- Design Load: 320 lbs.
- Call to specify material and finish

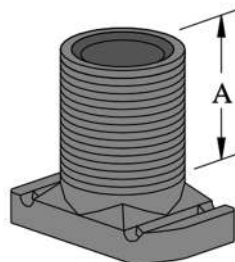

Item #

UTP2450

UNISTRUT
Electrical fittings

In-Channel Joiners - Straight

- Material: Cast aluminum.
- 3/8"-16 x 1/4" Socket Cup Point Set Screws Included
- Material: Aluminum

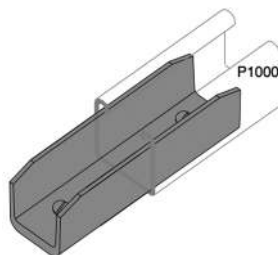

Item #

UTP2900AL

UNISTRUT
Electrical Fittings

In-Channel Joiners - Tee

- Material: Cast aluminum.
- 3/8"-16 x 1/4" Socket Cup Point Set Screws Included
- Material: Aluminum

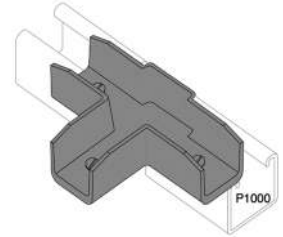

Item #

UTP2901AL

UNISTRUT
Electrical Fittings

In-Channel Joiners-L

- Material: Cast aluminum
- 3/8"-16 x 1/4" Socket Cup Point Set Screws Included
- Material: Aluminum

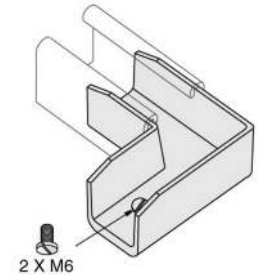

Item #

UTP2902AL

UNISTRUT
Electrical Fittings

In-Channel Joiners-X

- Material: Cast aluminum
- 3/8"-16 x 1/4" Socket Cup Point Set Screws Included
- Material: Aluminum

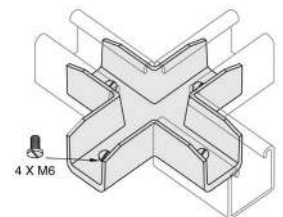

Item #

UTP2903AL

UNISTRUT
Electrical Fittings

Receptacle Box - Single Outlet

- Includes Nuts and Screws
- Call to specify material and finish

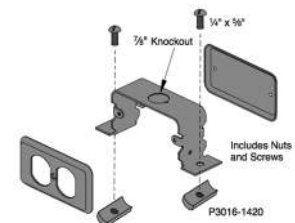

Item #

UTP2761

UNISTRUT
Electrical Fittings

Swivel Hanger

- Size: 1/2"
- Call to specify material and finish

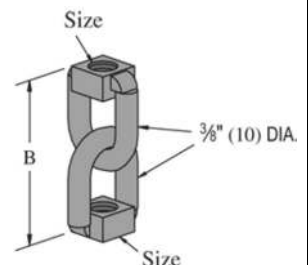

Item #

UTM2950

UNISTRUT

A BRAND OF atkore

UNISTRUT Electrical Fittings

Cable Entrance

Slot Size
3/4" (19.1) X
7/8" (22.2)

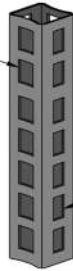

Slot Size
1 7/32" (13.5) X
7/8" (22.2)

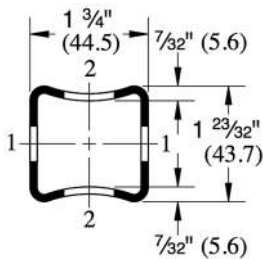

- Gauge: 12 (.105)
- Allowable Moment: 4,800 in-lbs
- Slot Spacing: 1 1/4" on center
- Call to specify material, finish and length

Item #
UTP16F

UNISTRUT Concrete Inserts

P32XX

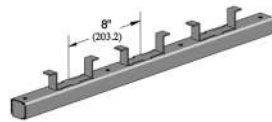

- Max. Allowable Point Load: 2,000 lbs.
- Min. Spacing of Pt. Loads: 12"
- Max. Allowable Uniform Load: 2,000 lbs.
- No Closure Strip, No End Caps, W/Back Plates
- Need to order Closure Strips separately
- Call to specify material, finish and length

Item #
UTP3270

UNISTRUT Concrete Inserts

P33XX

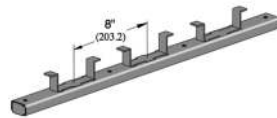

- 1-5/8" x 7/8" tall
- Insert Length: 20'
- Max. Allowable Point Load: 2,000 lbs.
- Min. Spacing of Pt. Loads: 12"
- Max. Allowable Uniform Load: 2,000 lbs.
- No Closure Strip, No End Caps, W/Back Plates
- Make sure to include Closure Strips
- Call to specify material finish and length

Item #
UTP3370X

UNISTRUT Closure Strip

P3712P-Plastic



- Material: Plastic
- Color: Black.
- Note: Use with P3170, P3270, and P3370 series concrete insert.
- Standard length: 10' (3m)

Item #
UTP3712P

UNISTRUT Concrete Inserts

End Cap Anchors

Note: End cap anchor for use with 1-5/8" wide standard Unistrut inserts only

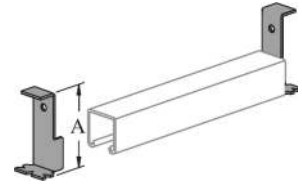

- Call to specify material and finish

Item #	Channel	'A'
UTP1704	P1000	2 13/32"
UTP3703	P3300	2 7/16"
UTP3704	P3000	3"

UNISTRUT Concrete Inserts

End Cap

- Call to specify material and finish

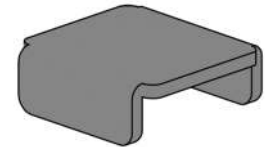

Item #	Fits Channel
UTP3280	P3000
UTP3380	P3300

UNISTRUT Concrete Inserts

Joint Covers

- Use with Insert Series: P3270
- *Note: Joint cover for use with 1-5/8" wide standard Unistrut inserts only.
- Call to specify material and finish

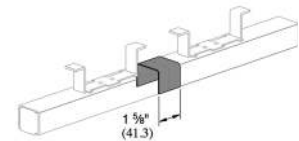

Item #
UTP3663

UNISTRUT 1 3/16" Series

P7000



- Allowable Moment: 180 in-lbs
- Call to specify material/finish

Item #
UTP7000

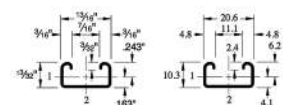



UNISTRUT

A BRAND OF **atkore**

UNISTRUT
13/16" Series

P6026 2 Hole

- Refer to Standard Dimensions for width, thickness, hole diameters and hole spacing
- Call to specify material and finish

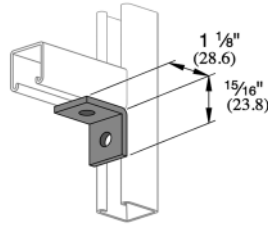

Item #

UTP6026

UNISTRUT
13/16" Series

P6917 5 Hole Gusset

- Refer to Standard Dimensions for width, thickness, hole diameters and hole spacing
- Call to specify material and finish

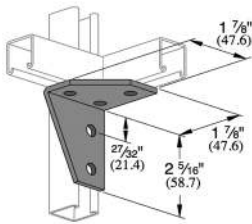

Item #

UTP6917

UNISTRUT
Fiberglass

20P2200 Slotted Channel

- Wt/100 ft. (lbs.): 82

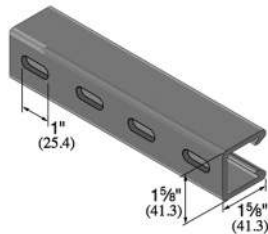

Item #

UF20P-2200-20

UNISTRUT
Fiberglass

20P2000 Single Channel

- Patented flange profile
- Area: 1.06"²[2]
- X - X Axis: I: 0.31 in[4]; R: 0.54"; C1: 0.70"; C2: 0.93"
- Y - Y Axis: I: 0.42 in[4]; R: 0.63"; C: 0.82"
- Wt/100 ft. (lbs.): 82

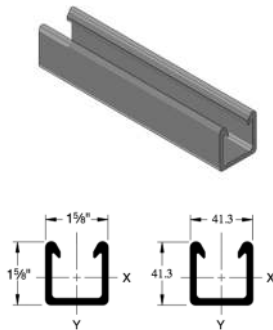

Item #

UT20P-2000-20

UNISTRUT
Fiberglass

20P2100 Back to Back

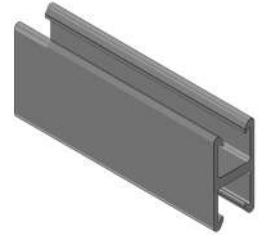

- Patented flange profile
- Area: 2.12"²[2]
- X - X Axis: I: 1.77 in[4]; R: 0.91"; C1: 1.63"; C2: 1.63"
- Y - Y Axis: I: 0.85 in[4]; R: 0.63"; C: 0.82"
- Wt/100 ft. (lbs.): 164

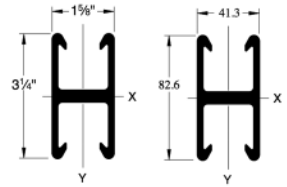

Item #

UT20P-2100-20

UNISTRUT
Fiberglass

Channel Nut - Heavy Duty

Heavy duty channel nuts are designed to be used where high thread shear values or spring nuts are required. They can not be used with light duty 1000 series channel or SST profile channel.

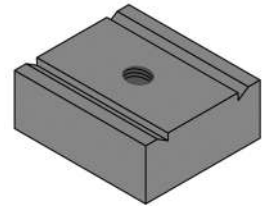

- Material: glass-reinforced polyurethane
- Thread shear values shown represent a 3:1 safety factor
- Wt/100 pcs. (lbs.): 5.7

Item #	Size	Thread Shear (lbs.)*	Torque (ft./lbs.)
UTF375PU-CNHD	3/8"-16	1,400	8
UTF500PU-CNHD	1/2"-13	1,400	8

UNISTRUT
Fiberglass

Channel Nut - Standard Duty

Standard Duty channel nuts are designed for light duty applications that do not require high thread shear values. They can be used with both light duty series 1000 and heavy duty series 2000 fiberglass channel.

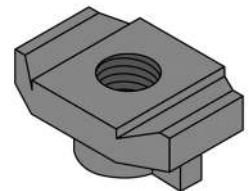

- Note: For use with SST profile channel
- Material: glass-reinforced polyurethane
- Thread shear values shown represent a 3:1 safety factor
- Wt/100 pcs. (lbs.): 1.8

Item #	Size	Thread Shear (lbs.)*	Torque (ft./lbs.)
UTF250PU-CN	1/4"-20	460	2
UTF375PU-CN	3/8"-16	460	3
UTF500PU-CN	1/2"-13	460	3

UNISTRUT®

A BRAND OF atkore

UNISTRUT Fiberglass

Threaded rods



- Material: Pultruded vinyl ester resin and is gray in color
- Ordered in eight foot lengths
- Thread shear values shown represent a 3:1 safety factor
- Wt/100 pcs. (lbs.): 3/8"-35, 1/2"-57

Item #	Size	Thread Shear (lbs.)*	Torque (ft./ lbs.)
UTF200-3827-96	3/8"-16	470	5
UTF200-3828-96	1/2"-13	570	10

UNISTRUT Fiberglass

6 Hole Gusset Tee

Wt/100 pcs. (lbs.): 50

Item #	Wt/100 pcs (Lbs)
UR20P-2530	50

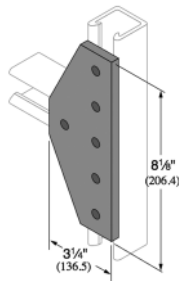

UNISTRUT Fiberglass

Post Base

Item #	Finish
UT20PU-5853	Fiberglass

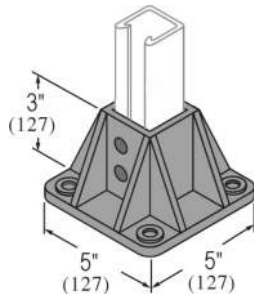

UNISTRUT Fiberglass

Clevis Hangers

- Material: Glass-reinforced polyester resin
- Size Range: 1 1/2" - 2"
- Hanger Rod: 1/2"
- Trans Rod: 3/8"
- Spreader Rod O.D.: 1/2"
- Loads: 60 lbs.
- Dimensions (T x H x H1 x W): 1/8" x 3 1/2" x 2 3/8" x 1 1/2"
- Wt/Per 100 pcs. (lbs.) 25

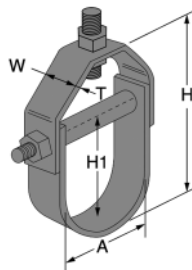

Item #
UTF100-1501

UNISTRUT Fiberglass

Rigid Pipe Clamps

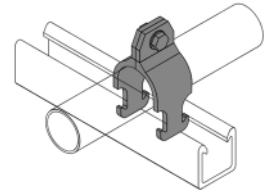

- Rigid Pipe Clamps resemble the more traditional style of pipe clamps and are sized based on the pipe inside diameter or nominal size
- Polyurethane clamps are recommended for applications up to 160°F; for high temperature applications (up to 230°F)
- Care should be taken not to exceed the recommended torque values of the rigid pipe clamps
- Material: Glass-reinforced polyurethane
- Design Loads: Type 1 - 225 lbs.; Type 2 - 90 lbs.
- FRP Bolt Size: 3/8" x 1-1/4"
- Torque (ft./lbs.): 3
- Wt/100 pcs. (lbs.): 5

Item #	Nom. Size	Rigid Metal
UTPCR-050	1/2"	0.840"
UTPCR-075	3/4"	1.050"
UTPCR-100	1"	1.315"
UTPCR-125	1 1/4"	1.660"
UTPCR-150	1 1/2"	1.900"
UTPCR-200	2"	2.375"

UNISTRUT Walkway Grating

G6XXXX

- Specify Height: 1-1/2", 2-1/2" or 4"
- Specify gauge: 14 or 18
- Specify leg shape: double-male or male-female
- Specify surface: slotted-smooth or anti-skid
- Finish is PG: Call for other material options

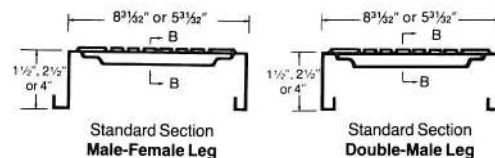

Item #	Width (in.)
UTG6XXXX	6



UNISTRUT®

A BRAND OF atkore

UNISTRUT Walkway Grating

G9XXXX

- Specify Height: 1-1/2", 2-1/2" or 4"
- Specify gauge: 14 or 18
- Specify leg shape: double-male or male-female
- Specify surface: slotted-smooth or anti-skid
- Finish is PG: Call for other material options



Item #	Width (in.)
UTG9XXXX	9

UNISTRUT Walkway Grating

Heel/Toe Side Plates

Forms a curb along grating length that defines a structure's side edge, and helps contain loose objects.

- 14 gauge

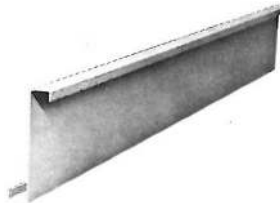

Item #	Height (in.)	Length (ft.)
UTG601PG	4	24
UTG631PG	6½	24
UTG621PG	8	12

UNISTRUT Walkway Grating

Heel/Toe End Plates

Forms a curb along ends that defines a structure's edge, and helps contain loose objects.

- 14 gauge



Item #	Height (in.)	Length (ft.)
UTG613PG	4	12
UTG622PG	6½	12
UTG623PG	8	12

UNISTRUT Walkway Grating

Grating Beam Clamp

- Attaches grating to structural I-beams. Requires no welding or drilling

Item #
UTG640EG



UNISTRUT Walkway Grating

"J" Bolt/Nut Lockwasher

- Attachment for attaching panels to supporting members from underside of grating

Item #
UTG600EG



UNISTRUT Walkway Grating

Support Plate

- Parallel support plate

Item #
UTG827B-PG
UTG837-PG
UT848B-PG
UTG860-PG



UNISTRUT Walkway Grating

Rib Clip

Item #
UTG811-AL

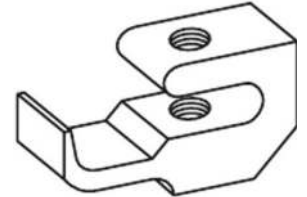

UNISTRUT Walkway Grating

Recessed Washer

Item #
UTG714-EG



ERICO®

ERICO/CADDY Top Beam Clamp



Item #	Rod Size	Flange Thickness (in.)	Rec# Load (lbs.) Top	Finish
ES3050037S4	¾"-16	¾	500	SS
ES3050050S4	½"-13	¾	1130	SS

ERICO®

ERICO/CADDY

Universal Beam Clamp



Item #	Rod Size	Flange Thickness (in.)
ES3000037EG	3/8"-16	3/4
ES3000037PL	3/8"-16	3/4
ES3000050EG	1/2"-13	3/4
ES3000050PL	1/2"-13	3/4
ES3000062PL	5/8"-11	3/4

ERICO/CADDY

Universal Beam Clamp

Wide Mouth



Item #	Rod Size	Flange Thickness (in.)
ES3100037EG	3/8"-16	1 1/4
ES3100037PL	3/8"-16	1 1/4
ES3100050EG	1/2"-13	1 1/4
ES3100050PL	1/2"-13	1 1/4

ERICO/CADDY

Beam Clamp

- Easy installation to beam flanges up to 1/2"
- Supports 1/4" and 3/8" threaded rod, S-hooks, electrical boxes, conduit and bridle rings
- Accommodates standard 1/4"-20 or #10-24 threaded bridle rings



Item #	Desc.	Static Load Limit (lbs.)
CABC	Beam Clamp thru 1/2" Flange	100

ERICO/CADDY Beam Clamp

Rod Lock



Caddy Rod Lock provides a quick and economical solution for installing electrical and mechanical systems supported by threaded rod. The system includes the Caddy Rod Lock beam clamp and channel nut. Simply push the threaded rod through the mounting hole and it instantly locks into position. The system can even be used on threaded rod with slightly damaged threads or minor burrs.

- Fits 3/8" rod
- Load Rating for flanges 1/8"-5/16" is 250 lbs. and for flanges 3/8"-7/16" is 500 lbs.
- UL@ 203 & UL 2239 Approved
- FM® Approved
- CRLB37EG Beam Clamp is FM Approved when installed in the bottom mount orientation
- CRLB37EG Beam Clamp is UL Listed for Fire Sprinkler Applications when a lock nut is installed on the threaded rod on the bottom side of the beam clamp
- For use on plain and electrogalvanized (EG) hardware only.
- Electrogalvanized ductile iron
- 3:1 Safety Factor

Item #

CACRLB37EG

ERICO/CADDY

Rod Lock Channel Nut



Caddy Rod Lock provides a quick and economical solution for installing electrical and mechanical systems supported by threaded rod. The system includes the Caddy Rod Lock beam clamp and channel nut. Simply push the threaded rod through the mounting hole and it instantly locks into position. The system can even be used on threaded rod with slightly damaged threads or minor burrs.

- Removable hex nut for use on half-slot side of strut
- Load capacity up to 750 lbs
- Electro-galvanized forged steel
- 3:1 Safety Factor
- For use on plain and electrogalvanized hardware only

Item #

CACRLS37EG

ERICO/CADDY

Threaded Strut Nut



Traditional spring nuts have to be selected based on strut depth. The SLICK Nut has eliminated the spring and easily fits all standard strut depths. The unique one-piece design eliminates the need for a washer.

- For use in indoor, outdoor and mildly corrosive environments
- Surface Finish: CADDY® ARMOUR

Item #

CASN37



ANVIL
Clevis Hangers

Fig. 260 Adjustable Clevis Hanger

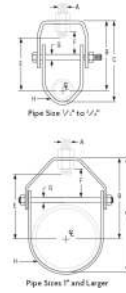

- Size Range: 1/2"-30"
- Material: Carbon steel
- Finish: Plain or Galvanized, also available plastic or epoxy coated
- Service: Recommended for the suspension of stationary pipe lines
- Maximum Temperature: Plain 650° F, Galvanized and Epoxy 450° F
- Approvals: Complies with Federal Specifications A-A-1192A (Type 1), UL, ULC Listed and FM Approved (Sizes 3/4" through 8")
- Installation: Hanger load nut above clevis must be tightened securely to assure proper hanger performance
- Adjustment: Vertical adjustment without removing pipe may be made from 3/8 through 5-1/8", varying with the size of the clevis; tighten upper nut after adjustment

Features:

- Design has yoke on outside of lower U-strap so yoke cannot slide toward center of bolt, thus bending of bolt is minimized
- Sizes 5" and up have rod and two nuts instead of bolt and nut, thread length on clevis rod is such that the thread locks the nuts in place, and threads are not in shear plane

Ordering:

- Specify pipe size, figure number, name and finish

Notes:

- Punched forming holes may be present on certain sizes of this clevis hanger; these holes are solely for the purpose of manufacturing, and do not effect the structural integrity or load carrying capacities of these hangers
- For insulated line options without shields, see Figures 260ISS and 300 - for insulated line options with shields, see Figures 167 and 168 - for ductile iron pipe sizes, see Figure 590

Caution:

- When an oversize clevis is used, a pipe spacer or multispaceer should be placed over clevis bolt to ensure that the lower U-strap will not move in on the bolt

Item #	Pipe Size (in.)	Max Load (lbs.)	Span (ft.)*	Weight (lbs.)	Rod Size A (in.)	B (in.)	C (in.)	Rod Take Out E (in.)	Adjust F (in.)	G (in.)
AV260-1/2	1/2	610	7	.34	3/8	2 1/16	2 1/16	1 1/2	5/8	1/4
AV260-3/4	3/4	610	7	.34	3/8	2	2 1/16	1 5/16	5/8	1/4
AV260-1	1	730	7	.35	3/8	2 5/16	3	1 5/8	5/8	1/4
AV260-1[1/4]	1 1/4	730	7	.40	3/8	2 3/8	3 1/4	1 11/16	5/8	1/4
AV260-1[1/2]	1 1/2	730	9	.45	3/8	2 13/16	3 13/16	2 1/8	7/8	1/4
AV260-2	2	730	10	.50	3/8	3 5/16	4 1/2	2 5/8	1 1/8	1/4
AV260-2[1/2]	2 1/2	1,350	11	.65	1/2	4 1/16	5 1/2	3 3/16	1 5/16	3/8
AV260-3	3	1,350	12	.85	1/2	4 3/4	6 1/2	4 1/16	1 5/8	3/8
AV260-3[1/2]	3 1/2	1,350	13	1.10	1/2	5 1/16	7 1/16	4 3/16	1 13/16	3/8
AV260-4	4	1,430	14	1.51	5/8	5 9/16	7 13/16	4 1/2	1 11/16	3/8
AV260-5	5	1,430	16	1.70	5/8	6 9/16	8 15/16	5 1/2	1 15/16	3/8
AV260-6	6	1,940	17	3.10	3/4	6 15/16	10 1/4	5 3/4	1 11/16	1/2
A260-8	8	2,000	19	4.75	3/4	8 3/8	12 11/16	7 3/16	2	1/2
AV260-10	10	3,600	22	8.60	7/8	9 7/8	15 1/4	8 7/16	2 1/8	5/8
AV260-12	12	3,800	23	11.20	7/8	11 1/16	17 15/16	10 1/8	2 13/16	5/8
AV260-14	14	4,200	25	12.50	1	12 9/16	19 9/16	10 11/16	2 11/16	3/4
AV260-16	16	4,600	27	19.85	1	14	22	12	2 3/4	1
AV260-18	18	4,800	28	22.25	1	15 15/16	24 15/16	13 15/16	3 13/16	1
AV260-20	20	4,800	30	40.33	1 1/4	17 9/16	27 9/16	15 3/16	3 7/8	1 1/4
AV260-24	24	4,800	32	49.83	1 1/4	19 13/16	31 13/16	17 9/16	3 7/8	1 1/4
AV260-30	30	6,000	33	70.18	1 1/4	24 3/16	39 3/16	21 9/16	5 1/8	1 1/4

Span represents the maximum recommended distance between hangers on a continuous and straight run of horizontal standard weight steel pipe filled with water. In all cases, verify that chosen location of hangers does not subject hangers to a load greater than the maximum recommended load shown above



ANVIL
Clevis Hangers

Fig 260ISS Clevis Hanger with Insulation Saddle System

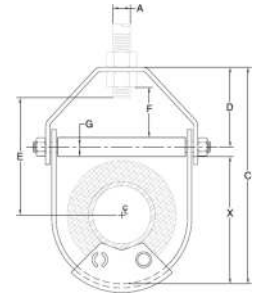

- Size Range: 2" through 16" clevis hanger with saddle system, 1/2" through 12" pipe diameter
- Material: Carbon steel with high impact glass reinforced polypropylene saddle and carbon steel spacer
- Finish: Plain or galvanized clevis hanger
- Service: Recommended for the suspension of stationary insulated chilled or hot water pipe lines
- Maximum Temperature: 40° F to 200° F
- Approvals: The 260ISS has been independently tested by ASTM & UL for flame spread (FSI), smoke development (SD) and drip ratings; the product has been approved by both agencies and has qualified for an ASTM E84 Class 1 25/60 rating, as well as a UL E94 VO rating which are the highest rating for this type of product by either agency
- Installation: Hanger load nut above clevis must be tightened securely to assure proper performance; install the pipe on the saddle, cope or notch one section of insulation to securely fit around the saddle, notch should be deep enough to extend 1/8" to 1/4" beyond the saddle, square cut adjoining insulation section and butt the mating end to the notched section; apply mastic to all mating insulation edges, caulk all seams between insulation and saddle as applicable to chilled or hot water systems to assure positive vapor barriers, finish via standard taping methods
- Adjustment: Vertical adjustment without removing the hanger may be made 7/8" through 2-3/8" varying with the size of the clevis

Features:

- Clevis hanger with high impact saddle eliminates costly hanger adjustments required during the installation of piping insulation
- Wood blocks and shields are not required for use with this product
- V-Block design cradles the pipe during and after installation
- Low thermal conductivity calculated at .77(BTU-In/Sq. Ft-Hr°F)
- Flammability rating of V-O UL 94

Ordering:

- Specify size number, insulation thickness, and finish

Item #	Max Load (lbs.)	Weight	Rod Size A (in.)	C (in.)	Rod Take Out E (in.)	Adjust F (in.)	G (in.)	X (in.)
AV260-2	550	.73	3/8	4 1/2	2 5/8	7/8	1/4	2 3/8
AV260-3	550	1.32	1/2	6 1/2	4 1/16	1 1/16	3/8	3 5/8
AV260-4	550	1.83	5/8	7 13/16	4 1/2	1 1/2	3/8	4 1/2
AV260-5	750	2.44	5/8	8 15/16	5 1/2	1 3/4	3/8	5 11/16
AV260-6	750	3.81	3/4	10 1/4	5 3/4	1 1/2	1/2	6 11/16
AV260-8	1100	5.60	3/4	12 11/16	7 3/16	1 3/4	1/2	8 3/16
AV260-10	1100	9.73	7/8	15 1/4	8 7/16	1 7/8	5/8	10 3/4
AV260-12	1700	13.80	7/8	17 15/16	10 1/8	2 5/16	5/8	12 7/16
AV260-14	1700	15.60	1	19 9/16	10 11/16	2 1/2	3/4	14 7/16
AV260-16	1700	26.81	1	22	12	2 3/8	1	16 5/16

Call for assistance with pipe hangers and stands.

We provide different finishes and stainless steel.



ANVIL
Beam Clamps

Fig. 292, 292L Universal Forged Steel Beam Clamp with Weldless Eye Nut

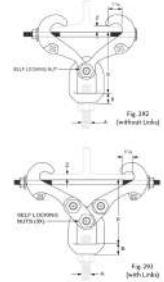

- Material: Forged steel
- Finish: Plain or Galvanized
- Service: For suspension of heavy loads from beams with flange widths to 15" and flange thickness to 1.031
- Approvals: Complies with Federal Specification A-A-1192A (Type 28 without links; Type 29 with links), WW-H-171-E (Type 28 without links; Type 29 with links), ANSI/MSS SP-69 and MSS-SP-58 (Type 28 without links; Type 29 with links)
- Installation: Fit jaws over edges of lower beam flange and tighten nuts on tie rod to lock clamp in place

Features:

- Weldless eye nut provides for horizontal pipe movement without binding
- Weldless eye nut is furnished tapped top any specified rod size up to the maximum rod size
- Tie rod assures a tight non-slip fit to the beam

Ordering:

- Specify clamp size, figure number, name, rod size and finish

Note:

- The application of a load to a structural beam by means of a beam clamp produces a traverse stress, perpendicular to the axis of the beam, in the flange to which the load is applied
- Clamp sizes 3,5 and 7 furnished with links

Item #	Clamp Size No.	Max Rod Size A (in.)	Max Load (lbs.)	Weight (lbs.)	Z Max (in.)	B (in.)	Jaw and Eye Nut Size (in.)
--------	----------------	----------------------	-----------------	---------------	-------------	---------	----------------------------

Right Handed Thread

AV292-1	1	3/4	3,230	3.9	.60	1 1/4	292-1/1
AV292-2	2	1	5,900	9.2	.60	1 11/16	292-2/2
AV292-3	3	1	5,900	13	.60	1 11/16	292-2/2
AV292-4	4	1	5,900	21.7	1.031	1 1/2	292-3/2
AV292-5	5	1	5,900	33.9	1.031	1 1/2	292-3/2
AV292-6	6	1 1/2	11,500	23.9	1.031	2 1/8	292-3/3
AV292-7	7	1 1/2	11,500	35.8	1.031	2 1/8	292-3/3
AV292-8	8	2	11,500	36.8	1.031	4 9/16	292-3/4

Left Handed Thread

AV292L-1	1	3/4	3,230	3.9	.60	1 1/4	292-1/1
AV292L-2	2	1	5,900	9.2	.60	1 11/16	292-2/2
AV292L-3	3	1	5,900	13	.60	1 11/16	292-2/2
AV292L-4	4	1	5,900	21.7	1.031	1 1/2	292-3/2
AV292L-5	5	1	5,900	33.9	1.031	1 1/2	292-3/2
AV292L-6	6	1 1/2	11,500	23.9	1.031	2 1/8	292-3/3
AV292L-7	7	1 1/2	11,500	35.8	1.031	2 1/8	292-3/3
AV292L-8	8	2	11,500	36.8	1.031	4 9/16	292-3/4

Make sure to get the right size beam clamps based on your required load!



ANVIL

Structural Attachments

Fig. 112, 113 Brace Fitting Complete Pipe End Only

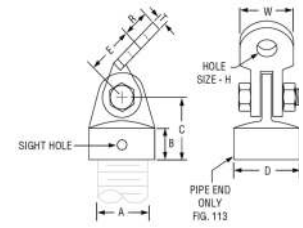

- Size Range: 1" and 1-1/4"
- Material: Malleable iron bracket and pipe end; hex cap screw and nut
- Finish: Plain
- Service: For bracing piping against sway and seismic movement
- Installation: Normally two fittings are used; a Fig. 112 complete attached to one end of an IPS nipple and a Fig. 113 pipe end only attached to the other end; the brace fitting completely connects to the building structure while the pipe end only connects to the pipe attachment. Use with Fig. 212 FP pipe clamp see page 34

Features:

- Two piece pivoted assembly accommodates any angle to structure; Sight hole in pipe end provides easy means of verifying proper thread engagement

Ordering:

- Specify size, figure number, name

Item #	Max Load (lbs.)	Weight (lbs.)	B (in.)	C (in.)	D (in.)	E (in.)	Hole Dia. H (in.)	R (in.)	T (in.)	W (in.)
--------	-----------------	---------------	---------	---------	---------	---------	-------------------	---------	---------	---------

Fig. 112

AV112-1	850	.95	1	2 ³ / ₁₆	1 ¹ / ₁₆	1 ¹ / ₂	9 ¹ / ₁₆	3 ¹ / ₄	1 ¹ / ₄	1 ¹ / ₂
AV112-1[1/4]	1,150	1.40	1	2 ³ / ₁₆	1 ¹ / ₂	3 ¹ / ₄	7 ¹ / ₈	5 ¹ / ₁₆	1 ³ / ₄	

Fig. 113

AV113-1	850	.50	1	2 ³ / ₁₆	1 ¹ / ₁₆	1 ¹ / ₂	9 ¹ / ₁₆	3 ¹ / ₄	1 ¹ / ₄	1 ¹ / ₂
AV113-1[1/4]	1150	.80	1	2 ³ / ₁₆	1 ¹ / ₂	3 ¹ / ₄	7 ¹ / ₈	5 ¹ / ₁₆	1 ³ / ₄	

ANVIL

Concrete Inserts And Attachments

Fig. 284 Metal Deck Hanger

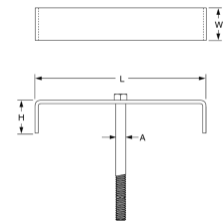

- Size Range: 3/8" through 3/4"
- Material: Carbon steel
- Finish: Plain
- Service: Recommended for suspending pipe or conduit in metal concrete deck forms for a variety of rod sizes; may be used with a rod coupling such as the Fig. 135 or 136 to allow for extended rod lengths

Features:

- L and H can be specified for a custom fit if your particular deck does not accommodate type A, B, or C
- Standard 6" long UNC bolt is welded to bracket to ensure assembly remains intact during shipment

Ordering:

- Specify Figure 284, design type (A,B, or C) and bolt diameter
- If your specific deck will not fit one of the design types and/or a different bolt size is required, specify leg height (H), opening (L), and bolt size

Item #	Bolt Size A (in.)	Max Load (lbs.)	L (in.)	H (In.)	W (in.)	Weight (lbs.)
--------	-------------------	-----------------	---------	---------	---------	---------------

Type A

AV284A-3/8	3/8	730	9 ¹ / ₈	1 ³ / ₄	1 ¹ / ₂	1.33
AV284A-1/2	1/2	1,350	9 ¹ / ₈	1 ³ / ₄	1 ¹ / ₂	1.43
AV284A-5/8	5/8	2,160	9 ¹ / ₈	1 ³ / ₄	1 ¹ / ₂	1.64
AV284A-3/4	3/4	3,230	9 ¹ / ₈	1 ³ / ₄	1 ¹ / ₂	1.92

Type B

AV248B-3/8	3/8	730	12	3	1 ¹ / ₂	2.23
AV248B-1/2	1/2	1,350	12	3	1 ¹ / ₂	2.33
AV248B-5/8	5/8	2,160	12	3	1 ¹ / ₂	2.54
AV248B-3/4	3/4	3,230	12	3	1 ¹ / ₂	2.82

Type C

AV248C-3/8	3/8	730	16	4	1 ¹ / ₂	3.10
AV248C-1/2	1/2	1,350	16	4	1 ¹ / ₂	3.20
AV248C-5/8	5/8	2,160	16	4	1 ¹ / ₂	3.41
AV248C-3/4	3/4	3,230	16	4	1 ¹ / ₂	3.69



TOLCO
Fig. 1

Standard Clevis Hanger

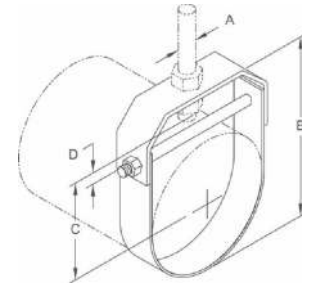

- Size Range: Size 1/2" thru 36" pipe
- Material: Carbon Steel
- Function: Recommended for the suspension of non-insulated pipe or pipe with Fig. 220 shield

Note:

- When an oversized clevis is used, a pipe spacer should be placed over the cross bolt to assure that the lower U-strap will not move in on the bolt
- When attaching seismic bracing to clevis hangers, a Fig. 1 CBS (cross bolt spacer) must be installed. See Tolco® Seismic Restraint Approval Guidelines
- Approvals: Underwriters' Laboratories Listed in the USA (UL), Canada (cUL) 3/4" thru 8" Conforms to Federal Specification WW-H-171E, Type 1, and Manufacturers Standardization Society SP-69, Type 1. Also available to accommodate rod schedule per National Fire Protection Association (NFPA) Pamphlet 13.
- Maximum Temperature: 650° F
- Finish: Plain

Note:

- Available in Electro-Galvanized and HDG finish or Stainless Steel

Item #	Pipe Size (in.)	Rod Size A (in.) STD	Rod Size (in.) NFPA	B (in.)	C (in.)	D (in.)	Max Rec. Load (lbs.)	Approx. Wt./100 (Lbs.)
TOL1-1/2	1/2	3/8	2 1/16	1 3/16	1	610	36	
TOL1-3/4	3/4	3/8	2 7/8	1 7/8	1	610	38	
TOL1-1	1	3/8	3 1/4	2 1/16	1	610	42	
TOL1-1-1/4	1 1/4	3/8	3 9/16	2 1/4	1	610	46	
TOL1-1-1/2	1 1/2	3/8	3 7/8	2 3/8	1	610	49	
TOL1-2	2	3/8	4 7/16	2 3/4	1	610	55	
TOL1-2-1/2	2 1/2	1/2	5 3/8	5 5/16	3 1/4	1	1,130	124
TOL1-3	3	1/2	5 3/8	5 15/16	3 1/2	1 1/4	1,130	140
TOL1-3-1/2	3 1/2	1/2	5 3/8	6 7/16	3 3/4	1 1/4	1,130	152
TOL1-4	4	5/8	5 3/8	7 3/8	4 1/4	1 1/2	1,430	190
TOL1-5	5	5/8	1/2	8 15/16	5 1/4	1 1/2	1,430	235
TOL1-6	6	3/4	1/2	9 13/16	5 1/2	1 1/2	1,940	317
TOL1-8	8	3/4	1/2	12 9/16	7 1/8	2	2,000	428
TOL1-10	10	7/8	5/8	16 1/4	9 5/8	3 1/4	3,600	918
TOL1-12	12	7/8	5/8	18 9/16	10 13/16	3 1/8	3,800	1,086
TOL1-14	14	1	-	20 3/4	12 3/8	4	4,200	1,267
TOL1-16	16	1	-	22 7/8	13 3/16	3 3/4	4600	1930
TOL1-18	18	1	-	25 3/4	15 9/32	4 7/16	4800	2264
TOL1-20	20	1 1/4	-	28 13/16	17 1/16	5 3/16	4800	3531
TOL1-24	24	1 1/4	-	32 1/8	18 1/4	4 7/16	4800	4431
TOL1-30	30	1 1/4	-	38 7/8	21 7/8	5	6000	6940
TOL1-36	36	1 1/2	-	48	27 3/4	5 3/4	9500	18103



TOLCO
Fig. 4

Standard Pipe Clamp

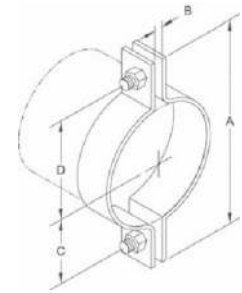

- Size Range: Size 1/2" thru 30" pipe
- Material: Carbon Steel
- Function: Recommended for the suspension of non-insulated pipe or insulated pipe with Fig. 220 shields. (Use Fig. 330 Weldless Eye Nut, Fig. 102 Eye Rod of Fig. 101 Welded Eye Rod.) Also recommended for attachment of sway bracing up to 3-1/2" pipe size, for larger pipe sizes use Fig. 4A. Fig. 4F and Fig 4PVC are designed to reduce noise and vibration and/or prevent electrolysis
- Approvals: Underwriters' Laboratories Listed in the USA (UL), Canada (cUL) 1/2" - 8", and approved by Factory Mutual Engineering, 3/4" - 8" Federal Specification WW-H-171E, Type 4, 1-1/2" - 24" and Manufacturers Standardization Society SP-69, Type 4.

Note:

- When the Fig. 4 is used as a sway brace, to ensure performance, the UL listing requires that it must be used with other Tolco® brace products
- Maximum Temperature: 750° F
- Finish: Plain

Note: Available in Electro-Galvanized and HDG finish or Stainless Steel materials

- Order By: Figure number, pipe size and finish

Order Note:

- Use Fig. 4F for felt lined clamp
- When ordering Fig. 4F allow for 3/16" felt on each half of clamp
- Use Fig. 4PVC for PVC Coated clamp

Item #	Pipe Size (in.)	A (in.)	B (in.)	C (in.)	D (in.)	Bolt Size (in.)	Max Design Load (lbs.) For Service Temp. 650°	Max Design Load (lbs.) For Service Temp. 750°	Approx. Wt./100 (Lbs.)
TOL4-1/2	1/2	3 ⁷ / ₁₆	1/4	1 ¹ / ₈	5 ¹ / ₁₆	500	445	29	
TOL4-3/4	3/4	3 ⁹ / ₁₆	1/4	1 ¹ / ₄	5 ¹ / ₁₆	500	445	31	
TOL4-1	1	3 ⁹ / ₁₆	1/4	1 ¹ / ₄	1 ⁵ / ₁₆	5 ¹ / ₁₆	500	445	35
TOL4-1-1/4	1 1/4	4 ³ / ₁₆	3/8	1 ³ / ₈	1 ¹¹ / ₁₆	5 ¹ / ₁₆	500	445	40
TOL4-1-1/2	1 1/2	4 ⁹ / ₁₆	3/8	1 ⁵ / ₈	1 ⁷ / ₈	5 ¹ / ₁₆	800	715	42
TOL4-2	2	5 ⁹ / ₁₆	3/8	2	2 ¹ / ₄	3/8	1,040	930	93
TOL4-2-1/2	2 1/2	6 ⁷ / ₁₆	3/8	2 ¹ / ₂	2 ³ / ₄	1/2	1,040	930	126
TOL4-3	3	7	3/8	2 ³ / ₄	3 ¹ / ₁₆	1/2	1,040	930	141
TOL4-3-1/2	3 1/2	7 ¹¹ / ₁₆	3/8	3 ¹ / ₈	3 ³ / ₈	1/2	1,040	930	154
TOL4-4	4	8 ¹ / ₂	5/8	3 ⁵ / ₁₆	3 ¹¹ / ₁₆	1/2	1,040	930	229
TOL4-5	5	9 ³ / ₄	3/4	3 ⁷ / ₈	4 ³ / ₈	5/8	1,040	930	261
TOL4-6	6	11 ⁵ / ₈	3/4	4 ⁷ / ₈	5 ¹ / ₈	3/4	1,615	1,440	537
TOL4-8	8	13 ⁵ / ₁₆	1	5 ⁵ / ₈	6	3/4	1,615	1,440	625
TOL4-10	10	16 ¹ / ₂	1	7 ¹ / ₄	7 ¹ / ₈	2,490	2,220	1,378	
TOL4-12	12	18 ¹ / ₂	1	8 ¹ / ₄	7 ¹ / ₈	2,490	2,220	1,574	
TOL4-14	14	20	1 ¹ / ₈	9	7 ¹ / ₈	2,490	2,220	2,103	
TOL4-16	16	23	1 ¹ / ₈	10 ¹ / ₄	7 ¹ / ₈	2,490	2,220	2,314	
TOL4-18	18	25 ⁷ / ₈	1 ¹ / ₄	11 ¹ / ₂	1	3,060	2,730	3,276	
TOL4-20	20	28	1 ³ / ₈	12 ¹ / ₂	1 ¹ / ₈	3,060	2,730	3,863	
TOL4-24	24	33 ¹ / ₂	1 ⁵ / ₈	15 ¹ / ₄	1 ¹ / ₄	3,060	2,730	5,222	
TOL4-30	30	41 ⁷ / ₈	2	19	1 ³ / ₄	3,500	3,360	10,511	



TOLCO
Fig. 4A

Pipe Clamp For Sway Bracing

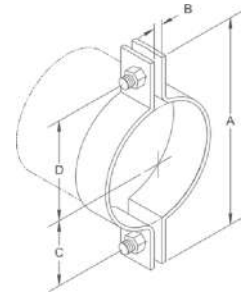

- Size Range: 4" thru 8" pipe. For Smaller than 4" use Tolco® Fig. 4
- Material: Carbon Steel
- Function: For bracing pipe against sway and seismic disturbance
- Approvals: Underwriters' Laboratories Listed in the USA (UL) and Canada (cUL) 4" thru 8" Included in our Seismic Restraints Catalog approved by the State Of California Office of Statewide Health Planning and Development (OSHDP)
- Installation Instructions: The Fig. 4A is the "braced pipe" attachment component of a longitudinal, lateral or riser brace assembly. It is intended to be combined with the "bracing pipe" and Tolco® transitional and structural attachment component(s) to form a complete bracing assembly. NFPA 13 and/or OSHPD guidelines should be followed
- To Install: place the Fig. 4A over the pipe to be braced. Attach Tolco® transitional fitting, either Fig. 980, 910, Or 909, to the clamp ears. Tighten bolts and nuts; torque requirement is a minimum of 50 ft. lbs. Transitional fitting attachment can pivot for adjustment to proper brace angle.
- Finish: Plain

Note:

- Available in Electro-Galvanized and HDG finish or Stainless Steel
- Order By: Figure number, pipe size and finish

Item #	Pipe Sizes (In.)	A (in.)	B (in.)	C (in.)	D (in.)	Bolt Size (in.)	Max. Horizontal Design Load (lbs.)	Approx. Wt./100 (Lbs.)
TOL4A-4	4	8½	⅞	3¾	3 ¹¹ / ₁₆	½	2,015	221
TOL4A-5	5	9¾	⅞	3¾	4¾	½	2,015	253
TOL4A-6	6	11½	⅞	5	5½	½	2,015	513
TOL4A-8	8	13¼	¾	6 ¹ / ₁₆	6½	½	2,015	601

TOLCO
Fig. 329

Adjustable Beam Clamp

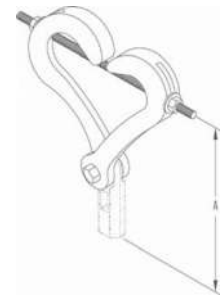

- Maximum Recommended Load: 1,290 lbs.
- Material: Malleable Iron
- Function: For attachment to beam flanges under normal service conditions where the flange thickness does not exceed 0.60" and where beam widths are from 2-3/8" min. to 7" max
- Approvals: Complies with Federal Specification WW-H-171E, Type 30 and Manufacturers Standardization Society SP-69, Type 30, when used with Fig. 333 Extension Piece
- Finish: Plain

Note: Available in Electro-Galvanized and HDG finish

Item #	A Min. (in.)	A Max (in.)	Bolt Size (in.)	Max. Rec. Load (lbs.)	Approx. Wt./100 (lbs.)
TOL-329	1⅞	3½	⅞	1,290	221



TOLCO
**Fig. 6,
Fig 6F,
Fig 6PVC**

Riser Clamps

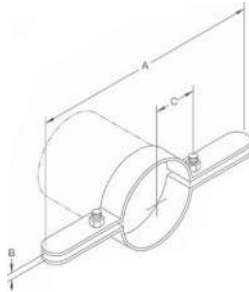

- Size Range : (Fig. 6) 1/2" thru 20" pipe, (Fig. 6F) 1/2" thru 2-1/2" copper tubing, (Fig. 6PVC) 1/2" thru 6" pipe
 - Material: Carbon Steel
 - Insulation Material: (Fig. 6F) 3/16" felt
 - Function: Used for supporting vertical piping
 - Approvals: Underwriters' Laboratories Listed in the USA (UL), Canada (cUL) 1/2" - 8". Factory Mutual Engineering Approved, 3/4" thru 8". Conforms to Federal Specification WW-H-171E, Type 8, 3/4" thru 20" and Manufacturers Standardization Society SP-69, Type 8
 - Maximum Temperature: 650°F
 - Finish: Plain
- Note:
- Available in Electro-Galvanized and HDG finish or Stainless Steel materials
 - Order By: Figure number, pipe size and finish

Item #	Pipe Size (in.)	A (in.)	B (in.)	C (in.)	Bolt Size (in.)	Max. Rec. Load (lbs.)
--------	-----------------	---------	---------	---------	-----------------	-----------------------

Figure 6

TOL6-1/2	1/2	9 1/4	1/2	1 1/8	3/8	255
TOL6-3/4	3/4	9 1/4	1/2	1 1/8	3/8	255
TOL6-1	1	9 9/16	1/2	1 1/4	3/8	255
TOL6-1-1/4	1 1/4	9 1 1/16	1/2	1 3/8	3/8	255
TOL6-1-1/2	1 1/2	10 3/8	1/2	1 1/2	3/8	255
TOL6-2	2	10 3/4	1/2	2	3/8	255
TOL6-2-1/2	2 1/2	11	5/8	2 1/4	3/8	390
TOL6-3	3	12	5/8	3	3/8	530
TOL6-3-1/2	3 1/2	13	5/8	3 1/4	1/2	670
TOL6-4	4	13 1/2	3/4	3 3/8	1/2	810
TOL6-5	5	14 1/2	3/4	4 3/8	1/2	1,160
TOL6-6	6	15 1/8	7/8	4 7/8	1/2	1,570
TOL6-8	8	18 1/2	1	5 3/4	5/8	2,500
TOL6-10	10	20 1/4	1	7 1/4	5/8	2,500
TOL6-12	12	22 3/4	1	8 1/4	5/8	2,700
TOL6-14	14	24	1 1/8	9	5/8	2,700
TOL6-16	16	26	1 1/8	10 1/4	3/4	2,900
TOL6-18	18	28	1 1/4	11 1/2	3/4	2,900
TOL6-20	20	30	1 3/8	12 1/2	3/4	2,900

Figure 6F

TOL6F-1/2	1/2	9 1/4	1/2	1 1/8	3/8	255
TOL6F-3/4	3/4	9 1/4	1/2	1 1/8	3/8	255
TOL6F-1	1	9 9/16	1/2	1 1/4	3/8	255
TOL6F-1-1/4	1 1/4	9 1 1/16	1/2	1 3/8	3/8	255
TOL6F-1-1/2	1 1/2	10 3/8	1/2	1 1/2	3/8	255
TOL6F-2	2	10 3/4	1/2	2	3/8	255
TOL6F-2-1/2	2 1/2	11	5/8	2 1/4	3/8	390

Figure 6PVC

TOL6PVC-1/2	1/2	9 1/4	1/2	1 1/8	3/8	255
TOL6PVC-3/4	3/4	9 1/4	1/2	1 1/8	3/8	255
TOL6PVC-1	1	9 9/16	1/2	1 1/4	3/8	255
TOL6PVC-1-1/4	1 1/4	9 1 1/16	1/2	1 3/8	3/8	255
TOL6PVC-1-1/2	1 1/2	10 3/8	1/2	1 1/2	3/8	255
TOL6PVC-2	2	10 3/4	1/2	2	3/8	255
TOL6PVC-2-1/2	2 1/2	11	5/8	2 1/4	3/8	390
TOL6PVC-3	3	12	5/8	3	3/8	530
TOL6PVC-3-1/2	3 1/2	13	5/8	3 1/4	1/2	670
TOL6PVC-4	4	13 1/2	3/4	3 3/8	1/2	810
TOL6PVC-5	5	14 1/2	3/4	4 3/8	1/2	1,160
TOL6PVC-6	6	15 1/8	7/8	4 7/8	1/2	1,570



TOLCO
Fig. 7

Offset Pipe Clamp

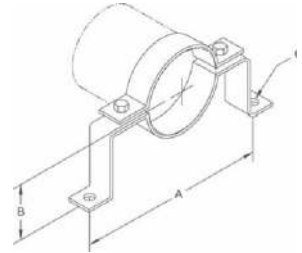

- Size Range: 1/2" thru 12" pipe
- Material: Carbon Steel
- Function: Recommended for support of pipe lines running at a definite distance from the wall or floor of a building or structure
- Maximum Temperature: 650° F
- Finish: Plain

Note:

- Available in ELECTRO-galvanized and HDG finish or Stainless Steel materials
- Special "B" dimensions available on request, consult factory
- Order By: Figure number, pipe size and finish

Item #	Pipe Size (in.)	A (in.)	B (in.)	Hole Size C (in.)	Bolt Size (in.)	Max Rec. Load (lbs.)	Approx. Wt./100 (Lbs.)
TOL7-1/2	1/2	5 ¹³ / ₁₆	2 ⁷ / ₁₆	7 ¹ / ₁₆	3 ⁸ / ₁₆	190	107
TOL7-3/4	3/4	5 ¹⁵ / ₁₆	2 ¹ / ₂	7 ¹ / ₁₆	3 ⁸ / ₁₆	190	109
TOL7-1	1	6 ¹ / ₄	2 ⁵ / ₈	7 ¹ / ₁₆	3 ⁸ / ₁₆	190	116
TOL7-1-1/4	1 1/4	6 ¹¹ / ₁₆	2 ³ / ₄	7 ¹ / ₁₆	3 ⁸ / ₁₆	190	126
TOL7-1-1/2	1 1/2	6 ¹⁵ / ₁₆	3	7 ¹ / ₁₆	3 ⁸ / ₁₆	190	134
TOL7-2	2	8 ⁵ / ₁₆	3 ³ / ₁₆	7 ¹ / ₁₆	3 ⁸ / ₁₆	420	191
TOL7-2-1/2	2 1/2	8 ⁷ / ₈	3 ⁷ / ₁₆	7 ¹ / ₁₆	3 ⁸ / ₁₆	420	209
TOL7-3	3	9 ¹ / ₂	3 ³ / ₄	7 ¹ / ₁₆	3 ⁸ / ₁₆	420	232
TOL7-3-1/2	3 1/2	10 ¹ / ₁₆	4	7 ¹ / ₁₆	3 ⁸ / ₁₆	420	250
TOL7-4	4	10 ⁹ / ₁₆	4 ¹ / ₄	9 ¹ / ₁₆	1 ² / ₂	610	370
TOL7-6	6	14 ³ / ₈	5 ⁵ / ₁₆	9 ¹ / ₁₆	1 ² / ₂	870	650
TOL7-8	8	16 ⁷ / ₁₆	6 ⁵ / ₁₆	9 ¹ / ₁₆	1 ² / ₂	870	787
TOL7-10	10	21 ¹ / ₂	7 ³ / ₈	1 ³ / ₁₆	3 ⁴ / ₄	925	1,238
TOL7-12	12	24 ⁷ / ₈	8 ³ / ₈	1 ³ / ₁₆	3 ⁴ / ₄	1,225	2,100

**Need other pipe clamps, clevis hangers,
and pipe supports?**

**Call for a full-line catalog and
all available specifications.**



TOLCO
Fig. 20
Standard Pipe Strap

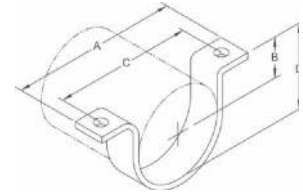

- Size Range: 1/2" thru 8" pipe
- Function: Recommended for supporting pipe with fittings vertically or horizontally to walls or ceiling. Fig 29S will support pipe flush with mounting surface
- Approvals: Conforms to Federal Specification WW-H-171E, Type 26 and Manufacturers Standardization Society SP-69, Type 26
- Order By: Figure number, pipe size, material and finish
- Optional: Fig. 20S, Flush Mount Pipe Strap

Item #	Pipe Sizes (In.)	A (in.)	B (in.)	C (in.)	D (in.)	Hole Size (in.)	Max. Rec. Load (lbs.)	Approx. Wt./100 (Lbs.)
TOL20-1/2	1/2	3/8	3/4	3 1/16	15/32	7/16	410	16
TOL20-3/4	3/4	4	1 1/16	3 1/8	1 5/16	7/16	410	21
TOL20-1	1	4 9/16	7/8	3 3/8	1 1/2	7/16	410	26
TOL20-1-1/4	1 1/4	4 15/16	1	3 3/4	1 7/8	7/16	410	30
TOL20-1-1/2	1 1/2	5 3/16	1 1/16	4 1/4	2 1/8	7/16	410	33
TOL20-2	2	5 3/4	1 7/16	4 3/4	2 5/8	7/16	410	38
TOL20-2-1/2	2 1/2	6 1/4	1 11/16	5 1/4	3 1/8	7/16	610	102
TOL20-3	3	6 7/8	2	5 7/8	3 3/4	7/16	610	118
TOL20-3-1/2	3 1/2	7 3/8	2 1/4	6 3/8	4 1/4	7/16	610	130
TOL20-4	4	8 3/8	2 1/2	7	4 3/4	9/16	725	159
TOL20-5	5	9[7]16	3 1/16	7 7/8	5 13/16	9/16	725	191
TOL20-6	6	10 1/2	3 5/8	8 7/8	6 7/8	9/16	725	234
TOL20-8	8	14	4 5/8	11 1/2	9	1 1/16	900	446

TOLCO
Fig. 30L, 30M, 30H
Welded Bracket

- Max. recommended Load: (Fig. 30L) 750 lbs., (Fig.30M) 1500 lbs., (Fig.30 H) 3000 lbs.
- Function: Recommended for supporting pipe on top or hanging through support bracket outward from mounting surface
- Approvals: Conforms with the following Federal Specification WW-H-171E and Manufacturers Standardization Society Types; 30L - WW-H-171E Type 32 and MSS SP-69 Type 31, 30M- WW-H-171E, Type 33 and MSS SP-69 Type 32, 30H- WW--171E, Type 34 and MSS SP-69 Type 33

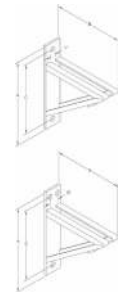

Item #	Sizes	A (in.)	B (in.)	C (in.)	D (in.)	Hole Size (in.)	Max. Rec. Load (lbs.)	Approx. Wt./100 (Lbs.)
--------	-------	---------	---------	---------	---------	-----------------	-----------------------	-------------------------

Fig. 30L

TOL30L-1	1	13	9	11 1/2	*	9/16	750	571
TOL30L-2	2	17	13	15 1/2	*	9/16	750	769
TOL30L-3	3	23	19	21 1/2	*	9/16]	750	1,057

Fig. 30M

TOL30M-0	0	18	12	15 1/2	*	1 3/16	1,500	1,577
TOL30M-1	1	24	18	21 1/2	*	1 3/16	1,500	2,578
TOL30M-2	2	30	24	27 1/2	*	1 3/16	1,500	4,446

Fig. 30H

TOL30H-1	1	18	12	15 1/4	*	1 1/8	3,000	2,195
TOL30H-2	2	24	18	21 1/4	2 1/2	1 1/8	3,000	4,398
TOL30H-3	3	30	24	27 1/4	2 1/2	1 1/8	3,000	6,294
TOL30H-4	4	36	30	33	2 1/2	1 1/8	3,000	7,196
TOL30H-5	5	42	36	39	3 1/2	1 1/8	3,000	13,197
TOL30H-6	6	50	42	46	3 1/2	1 1/8	3,000	15,795

* Only One Hole



TOLCO
Fig. 110

Standard U-Bolt with 4 Hex Nuts

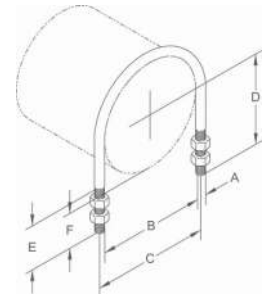

- Size Range: Size 1/2" thru 36" pipe
- Material: Carbon Steel
- Function: Recommended for support, anchor or guide of pipe
- Approvals: Conform to Federal Specification WW-H-171E, Type 24 an Manufacturers Standardization Society SP-69 Type 24
- Maximum Temperature 750° F
- Finish Plain

Note:

- Available in Electro-Galvanized and HDG finish or Stainless Steel materials
- Order By: Figure number, pipe size and finish

Note:

- When furnished in Hot-Dip Galvanized finish, oversize tapped hex nuts must be used

Item #	Rod Size A (in.)	Pipe Size (in.)	B (in.)	C (in.)	D (in.)	E (in.)	F (in.)	Max. Rec. Load (lbs.) for Service Temp. 650° F	Max. Rec. Load (lbs.) for Service Temp. 750° F
TOL110-1/4-1/2	1/4	1/2	15/16	13/16	23/4	21/8	25/16	485	435
TOL110-1/4-3/4	1/4	3/4	11/8	13/8	23/4	21/8	27/32	485	435
TOL110-1/4-1	1/4	1	13/8	15/8	23/4	21/8	29/32	485	738
TOL110-3/8-1-1/4	3/8	1 1/4	111/16	21/16	27/8	21/8	21/32	1,220	1,090
TOL110-3/8-1-1/2	3/8	1 1/2	2	23/8	3	21/2	21/16	1,200	1,090
TOL110-3/8-2	3/8	2	27/16	213/16	3 1/4	21/2	21/16	1,220	1,090
TOL110-1/2-2-1/2	1/2	2 1/2	215/16	37/16	3 3/4	3	25/16	2,260	2,020
TOL110-1/2-3	1/2	3	39/16	41/16	4	3	21/4	2,260	2,020
TOL110-1/2-3-1/2	1/2	3 1/2	41/16	49/16	4 1/4	3	21/4	2,260	2,020
TOL110-1/2-4	1/2	4	49/16	51/16	4 1/2	3	21/4	2,260	2,020
TOL110-1/2-5	1/2	5	55/8	61/8	5	3	27/32	2,260	2,020
TOL110-5/8-6	5/8	6	63/4	73/8	6 1/8	33/4	213/16	3,620	3,260
TOL110-5/8-8	5/8	8	83/4	93/8	7 1/8	33/4	213/16	3,620	3,230
TOL110-3/4-10	3/4	10	107/8	115/8	8 3/8	4	3	5,420	4,830
TOL110-7/8-12	7/8	12	127/8	133/4	9 5/8	4 1/4	3 1/4	7,540	6,730
TOL110-7/8-14	7/8	14	14 1/8	15	10 1/4	4 1/4	3 1/4	7,540	6,730
TOL110-7/8-16	7/8	16	16 1/8	17	11 1/4	4 1/4	3 1/4	7,540	6,730
TOL110-1-18	1	18	18 1/8	19 1/8	12 5/8	4 3/4	3 5/8	9,920	8,850
TOL110-1-20	1	20	20 1/8	21 1/8	13 5/8	4 3/4	3 5/8	9,920	8,850
TOL110-1-24	1	24	24 1/8	25 1/8	15 5/8	4 3/4	3 5/8	9,920	8,850
TOL110-1-30	1	30	30 1/8	31 1/8	18 5/8	4 3/4	3 5/8	9,920	8,850
TOL110-1-36	1	36	36 1/8	37 1/8	21 5/8	4 3/4	3 5/8	9,920	8,850



TOLCO
Fig. 304

Weld Beam Attachment

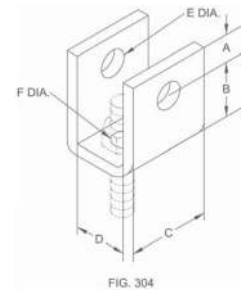

- Size Range: 3/8" thru 3-1/2" rod
- Material: Carbon Steel
- Function: Designed for attaching hanger rod to bottom of steel structures. Can be used in an upright (Fig. 304) or inverted position (Fig. 305). When using Fig. 305, attach hanger rod to bolt or pin with a Fig. 330 Weldless Eye Nut or Fig. 101 and Fig. 102 series Eyerods
- Approvals: Conforms to Federal Specification WW-H-171E, Type 22 and Manufacturers Standardization Society SP-69, Type 22
- Finish: Plain

Note: Available in Electro-Galvanized and HDG finish or Stainless Steel materials

- Order By: Figure number, rod size and finish

Item #	Rod Size (in.)	A (in.)	B (in.)	C (in.)	D (in.)	E (in.)	F (in.)	Bolt Size (in.)	Max. Rec. Load (lbs.) 650°F/ 750°F	Approx. Wt. per 100 (Lbs.)
TOL304-3/8	3/8	7/8	2	1 1/4	9/16	7/16	1/2x2 1/2	610/510	86	
TOL304-1/2	1/2	7/8	2	1 1/4	11/16	9/16	5/8x2 1/2	1,130/940	83	
TOL304-5/8	5/8	1	2	1 1/4	13/16	1 1/16	3/4x2 3/4	1,810/1,510	84	
TOL304-3/4	3/4	1 1/8	2	2 1/2	1 1/2	1 5/16	13/16	7/8x3	2710/2260	174
TOL304-7/8	7/8	1 1/4	3	2 1/2	2	1 1/8	1 5/16	1x4	3,770/3,150	232
TOL304-1	1	1 1/2	3	2	1 1/4	1 1/8	1 1/2x4 1/2	4,960/4,150	394	
TOL304-1-1/4	1 1/4	2	3	4	2 1/2	1 5/8	1 3/8	1 1/2x5 3/4	8,000/6,660	738
TOL304-1-1/2	1 1/2	2 1/2	4	5	3	1 7/8	1 5/8	1 3/4x6 1/2	11,630/ 9,700	1,449
TOL304-1-3/4	1 3/4	2 3/4	5	3 3/4	2 1/8	1 7/8	2x7 3/4	15,700/ 14,000	1,747	
TOL304-2	2	3 1/4	5	6	3 3/4	2 3/8	2 1/8	2 1/4x7 3/4	20,700/ 18,460	2,201
TOL304-2-1/4	2 1/4	3 1/2	6	4 1/2	2 5/8	2	2 1/2x7 3/4	27,200/ 24,260	2,523	
TOL304-2-1/2	2 1/2	3 3/4	6	4 1/2	2 7/8	2 3/8	2 3/4x8	33,500/ 29,880	2,552	
TOL304-2-3/4	2 3/4	4	5 3/4	6	3 3/4	3 1/8	-	3x7 5/8	41,580/ 37,066	2,675
TOL304-3	3	4	6 1/4	7	3 3/4	3 3/8	-	3 1/4x7 5/8	50,580/ 45,085	3,250
TOL304-3-1/4	3 1/4	4 1/2	7	4 1/4	3 5/8	-	3 1/2x8 1/2	60,480/ 53,906	4,500	
TOL304-3-1/2	3 1/2	4 1/2	7 1/2	8	4 1/4	3 7/8	-	3 3/4x8 1/2	71,280x63, 493	5,320



TOLCO
Fig. 313

Adjustable Pipe Support with U-Bolt

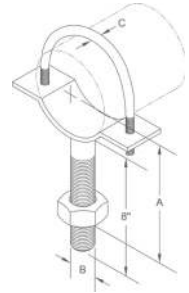

- Size Range: Size 2" thru 12" pipe
- Material: Carbon Steel
- Function: Designed to support horizontal pipe from floor stanchion where vertical adjustment is required. U-bolt and hex nuts are provided to hold pipe securely to saddle
- Maximum Temperature: 650°F
- Finish: Plain

Note:

- Available in Electro-Galvanized and HDG finish or Stainless Steel materials
- Order By: Figure number, pipe size and finish

Item #	Pipe Size (in.)	Max. O.D. Pipe (in.)	A Min. (in.)	A Max (in.)	B (in.)	C (in.)	Use With Fig. 316 Stand Pipe Size
TOL313-2	2	2 ³ / ₈	2 ¹ / ₄	6	7 ¹ / ₈	3 ¹ / ₈	1
TOL313-2-1/2	2 ¹ / ₂	2 ⁷ / ₈	3 ¹ / ₄	6 ¹ / ₂	7 ¹ / ₈	3 ¹ / ₈	1
TOL313-3	3	4	3 ¹ / ₂	6 ³ / ₄	7 ¹ / ₈	1 ¹ / ₂	1
TOL313-3-1/2	3 ¹ / ₂	4	3 ¹ / ₂	6 ³ / ₄	7 ¹ / ₈	1 ¹ / ₂	1
TOL313-4	4	4 ⁷ / ₈	4 ¹ / ₄	7 ¹ / ₂	1	1 ¹ / ₂	1
TOL313-5	5	5 ⁵ / ₈	4 ¹ / ₂	7 ³ / ₄	1	1 ¹ / ₂	1
TOL313-6	6	7	5 ⁵ / ₈	8 ³ / ₈	1 ¹ / ₄	5 ⁵ / ₈	1 ¹ / ₄
TOL313-8	8	9 ¹ / ₈	6 ³ / ₄	9 ¹ / ₂	1 ¹ / ₄	5 ⁵ / ₈	1 ¹ / ₄
TOL313-10	10	11 ¹ / ₈	8	10	1 ¹ / ₄	3 ³ / ₄	1 ¹ / ₄
TOL313-12	12	13 ¹ / ₂	9 ¹ / ₄	11 ¹ / ₄	1 ¹ / ₄	7 ¹ / ₈	1 ¹ / ₄

TOLCO
Fig. 314

Flange Support

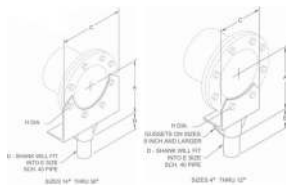

- Size Range: Size 4" thru 36" pipe
- Material: Carbon Steel
- Function: Designed to support 125 lb. cast iron and 150 lb. forged steel flanged connections. (Consult factory for other flanged bolt patterns). To complete floor stanchion, use Fig. 316 Stand Pipe. For complete floor stanchion with vertical adjustment, use Fig. 319 Threaded Pipe with Adjuster and Fig. 316T Threaded Pipe Stand
- Approvals: Conforms to Federal Specification WW-H-171E, Type 38, 4" thru 36" and Manufacturers Standardization Society SP-69, Type 37
- Maximum Temperature: 750°F
- Finish: Plain

Note:

- Available in Electro-Galvanized and HDG finish or Stainless Steel materials
- Order By: Figure number, pipe size and finish

Item #	Pipe Size (in.)	A (in.)	B (in.)	C (in.)	D (in.)	E (in.)	H (in.)
TOL314-4	4	6 ⁷ / ₈	2	6 ³ / ₈	2 ³ / ₈	2 ¹ / ₂	3 ⁴ / ₈
TOL314-5	5	7 ³ / ₈	2	7 ¹ / ₁₆	2 ³ / ₈	2 ¹ / ₂	7 ⁷ / ₈
TOL314-6	6	7 ⁷ / ₈	2	7 ³ / ₄	2 ³ / ₈	2 ¹ / ₂	7 ⁷ / ₈
TOL314-8	8	10 ¹ / ₈	2	9 ⁹ / ₁₆	2 ³ / ₈	2 ¹ / ₂	7 ⁷ / ₈
TOL314-10	10	11 ³ / ₈	2	8	2 ³ / ₈	2 ¹ / ₂	1
TOL314-12	12	12 ⁷ / ₈	3	9 ¹ / ₂	2 ³ / ₈	2 ¹ / ₂	1
TOL314-14	14	15	3	18 ³ / ₁₆	2 ⁷ / ₈	3	1 ¹ / ₈
TOL314-16	16	16 ¹ / ₄	3	16 ⁵ / ₈	2 ⁷ / ₈	3	1 ¹ / ₈
TOL314-18	18	4	17 ¹¹ / ₁₆	3 ³ / ₄	4	1 ¹ / ₄	
TOL314-20	20	19 ¹ / ₄	4	15 ³ / ₄	3 ³ / ₄	4	1 ¹ / ₄
TOL314-22	22	20 ¹ / ₄	4	16 ⁵ / ₁₆	3 ³ / ₄	4	1 ³ / ₈
TOL314-24	24	22 ¹ / ₂	4	18 ³ / ₈	3 ³ / ₄	4	1 ³ / ₈
TOL314-26	26	23 ⁵ / ₈	4	17 ¹ / ₈	3 ³ / ₄	4	1 ³ / ₈
TOL314-30	30	25 ⁷ / ₈	4	16 ³ / ₈	3 ³ / ₄	4	1 ³ / ₈
TOL314-32	32	27 ³ / ₈	4	17 ⁷ / ₈	3 ³ / ₄	4	1 ⁵ / ₈
TOL314-36	36	29 ¹ / ₂	4	17 ¹ / ₂	3 ³ / ₄	4	1 ⁵ / ₈



TOLCO
Fig. 316, Fig. 316T

Stand Pipe and Threaded Stand Pipe

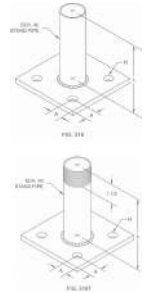

- Size Range: 1" thru 8" pipe
- Material: Carbon Steel
- Function: Fig. 316 provides the support base for a floor stanchion support. Use with Fig. 311, Fig. 312, Fig. 313, Fig. 314, Fig. 315, Fig. 317 or Fig. 318. Fig. 316T provides a threaded support base for a floor stanchion support where vertical adjustment is required. Use with Fig. 317A or Fig. 318A or Fig. 319 and use with Fig. 311 thru Fig. 318
- Finish: Plain

Note:

- Available in Electro-Galvanized and HDG finish or Stainless Steel materials
- Order By: Figure number, pipe size, "L" dimension and finish

Item #	Stand Pipe Size (in.)	A (in.)	H (in.)	Plate Size (sq. in.)
Figure 316				
TOL316-1	1	½	6	
TOL316-1-1/4	1¼	1	½	6
TOL316-1-1/2	1½	1	½	6
TOL316-2	2	1	½	6
TOL316-2-1/2	2½	1⅞	⅝	7½
TOL316-3	3	1⅞	⅝	9
TOL316-4	4	1¾	¾	11
TOL316-6	6	1½	⅞	13½
TOL316-8	8	1½	1	16
Figure 316T				
TOL316T-1	1	½	6	
TOL316T-1-1/4	1¼	1	½	6
TOL316T-1-1/2	1½	1	½	6
TOL316T-2	2	1	½	6
TOL316T-2-1/2	2½	1⅞	⅝	7½
TOL316T-3	3	1⅞	⅝	9
TOL316T-4	4	1¾	¾	11
TOL316T-6	6	1½	⅞	13½
TOL316T-8	8	1½	1	16

**Edge rents and repairs all
sorts of equipment.**



TOLCO
Fig. 317

Pipe Saddle

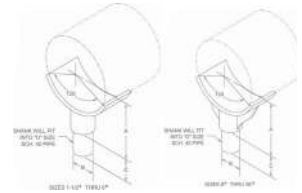

- Size Range: 1-1/2" thru 36" pipe
- Material: Carbon Steel
- Function: Designed to support horizontal pipe from floor stanchion. To complete floor stanchion, use with Fig. 316 Stand Pipe. For complete floor stanchion with vertical adjustment, use Fig. 319 Threaded Pipe with Adjuster and Fig. 316T Threaded Stand Pipe
- Approvals: Conforms to Federal Specification WW-H-171E, Type 37, 4" thru 36", and Manufacturers Standardization Society SP-69, Type 36
- Maximum Temperature: 750°F
- Finish: Plain

Note:

- Available in Electro-Galvanized and HDG finish or Stainless Steel materials
- Order By: Figure number, pipe size and finish

Item #	Pipe Size (in.)	Max. O.D. Pipe (in.)	A (in.)	B (in.)	C (in.)	D (in.)
TOL317-1-1/2	1½	2	2¼	1	2	1
TOL317-2	2	2¾	2⅞	1	2	1
TOL317-2-1/2	2½	2⅞	2⅞	1½	2	1½
TOL317-3	3	3½	3	1½	2	1½
TOL317-3-1/2	3½	4	3¼	1½	2	1½
TOL317-4	4	4⅞	3⅞	2¾	3	2½
TOL317-5	5	5¾	4⅞	2¾	3	2½
TOL317-6	6	7	4⅞	2¾	3	2½
TOL317-8	8	9⅞	6⅞	2¾	4	2½
TOL317-10	10	11⅞	7⅞	2¾	4	2½
TOL317-12	12	13½	9⅞	2¾	4	2½
TOL317-14	14	10½	2⅞	4	3	
TOL317-16	16	11½	2⅞	4	3	
TOL317-18	18	13½	3¼	4		
TOL317-20	20	14½	3¼	4		
TOL317-22	22	15½	3¼	4		
TOL317-24	24	17½	3¼	4		
TOL317-26	26	18½	3¼	4		
TOL317-30	30	20¾	3¼	4		
TOL317-32	32	21¾	3¼	4		
TOL317-36	36	23¾	3¼	4		

Call for help with your submittals.



TOLCO
Fig. 318A

Pipe Saddle with U-Bolt and Threaded Pipe Adjuster

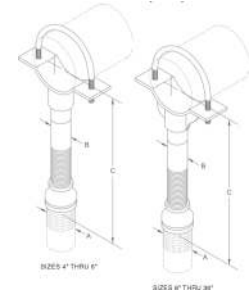

- Size Range: 4" thru 36" pipe
- Material: Carbon Steel with cast iron reducer
- Function: Designed to support horizontal pipe from floor stanchion where vertical adjustment is required. U-bolt and hex nuts are provided to hold pipe securely to saddle. To complete floor stanchion, use with Fig. 316T Threaded Pipe Stand
- Approvals: Conforms to Federal Specification WW-H-171E, Type 38, 4" thru 36", and Manufacturers Standardization Society SP-69, Type 37
- Finish: Plain

Note:

- Available in Electro-Galvanized and HDG finish or Stainless Steel materials
- Order By: Figure number, pipe size, adjuster size and finish

Note:

- Order with Tolco® Fig. 316T for complete stanchion support

Item #	Pipe Size (in.)	A Stand Pipe Size (in.)	B Adj. Pipe Size (in.)	C Min. (in.)	C Max. (in.)	Approx. Wt./100 (Lbs.)
TOL318A-4	4	3	2½	10¼	14¾	1,413
TOL318A-5	5	3	2½	11⅛	15⅝	1,453
TOL318A-6	6	3	2½	11⅞	16⅜	1,628
TOL318A-8	8	3	2½	13⅞	18⅜	1,913
TOL318A-10	10	3	2½	14⅝	19⅞	2,193
TOL318A-12	12	3	2½	15⅝	20⅞	2,593
TOL318A-14	14	4	3	18⅞	23⅞	4,150
TOL318A-16	16	4	3	19⅞	24⅞	4,445
TOL318A-18	18	6	4	22¼	26¾	4,468
TOL318A-20	20	6	4	23¼	27¾	6,557
TOL318A-22	22	6	4	24¼	28¾	6,908
TOL318A-24	24	6	4	26½	31	7,436
TOL318A-26	26	6	4	27½	32	7,768
TOL318A-30	30	6	4	29⅝	34⅞	9,196
TOL318A-32	32	6	4	30⅝	35⅞	9,575
TOL318A-36	36	6	4	32⅝	37⅞	10,294

Make sure to specify pipe type, size, and height above floor.



TOLCO
Fig. 322

Pipe Roll with Sockets

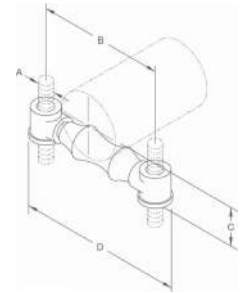

- Size Range: 1" thru 30" pipe
- Material: Cast Iron and carbon steel axle
- Function: For supporting pipe where expansion may occur due to thermal movement. Double rod design provides support for greater loads
- Approvals: Conforms to Federal Specification WW-H-171E, Type 42, 2" thru 24", and Manufacturers Standardization Society Sp-69, Type 41

Note: When pipe line is insulated, total outside diameter of pipe and covering should be used to determine size of hanger; also see figs. 260-1 to 265-4

- Finish: Plain
- Note: Available in Electro-Galvanized and HDG finish
- Order By: Figure number, pipe size and finish

Item #	Pipe Size (in.)	A (in.)	B (in.)*	C (in.)	D (in.)	Max. Rec. Load (lbs.)	Approx. Wt./100 (lbs.)
TOL322-1	1	3/8	3 1/4	1 21/32	4 1/8	600	45
TLL322-1-1/4	1 1/4	3/8	3 3/8	1 13/16	4 1/2	600	48
TOL322-1-1/2	1 1/2	3/8	3 5/8	1 15/16	4 3/4	600	51
TOL322-2	2	3/8	4 1/8	2 1/4	5 7/16	600	58
TOL322-2-1/2	2 1/2	1/2	4 7/8	2 5/8	6 1/4	660	123
TOL322-3	3	1/2	5 1/2	2 7/8	6 7/8	700	133
TOL322-3-1/2	3 1/2	1/2	6	3 1/4	7 3/8	750	146
TOL322-4	4	5/8	6 7/8	3 3/4	8 7/16	750	230
TOL322-5	5	5/8	8 1/4	4 1/4	9 9/16	750	285
TOL322-6	6	3/4	9 5/8	5 1/8	11 1/16	1,070	460
TOL322-8	8	7/8	11 13/16	6 1 1/32	14	1,350	720
TOL322-10	10	7/8	14	7 9/16	16 3/16	1,730	1,100
TOL322-12	12	7/8	16	8 1 1/16	18 3/16	2,400	1,630
TOL322-14	14	1	18	9 21/32	20 1 1/16	3,130	2,150
TOL322-16	16	1 1/4	20 1/4	10 3/4	23	3,970	2,850
TOL322-18	18	1 1/4	22 1/2	11 25/32	25 1/4	4,200	3,650
TOL322-20	20	1 1/4	25	12 15/16	26 1/4	4,550	4,650
TOL322-24	24	1 1/2	28 5/8	16 1 3/32	31 7/8	6,160	6,200
TOL322-30	30	1 1/2	34 1/2	19 3/4	39 5/8	7,290	12,500

*** Due to the inconsistent dimensions associated with cast parts, please contact the factory if the "B" dimension is critical for installation**



TOLCO
Fig.330

Weldless Steel Eye Nut

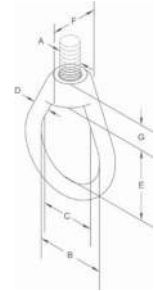

- Size Range: 3/8" thru 2-1/2" machine thread
- Material: Forged Steel
- Quality Assurance: Conforms to the requirements of NCA 3800
- Threads: Tapped UNC Class 2B. Right hand threads are standard. Left hand threads supplied upon request
- Function: Used on piping installations where high strength and swivel action are required. Left hand tap is also available
- Approvals: Complies with Federal Specification WW-H-171E, Type 17 and Manufacturers Standardization Society SP-69, Type 17
- Finish: Plain

Note:

- Available in Electro-Galvanized and HDG finish

Item #	Rod Size A (in.)	B (in.)	C (in.)	D (in.)	E (in.)	F (in.)	G (in.)	Max. Rec. Load (lbs.) 650°F	Max. Rec. Load (lbs.) 750°F	Approx. Wt./100 (Lbs.)
TOL330-3/8	3/8	1 1/2	1 3/16	1/2	2	1 3/8	1 1/16	610	540	63
TOL330-1/2	1/2	1 1/2	1 3/16	1/2	2	1 3/8	1 1/16	1,130	1,010	60
TOL330-5/8	5/8	1 1/2	1 3/16	1/2	2	1 3/8	1 1/16	1,810	1,610	59
TOL330-3/4	3/4	1 1/2	1 3/16	1/2	2	1 3/8	1 1/16	2,710	2,420	56
TOL330-7/8	7/8	2	1 1/16	3/4	2 5/8	1 15/16	1	3,770	3,360	170
TOL330-1	1	2	1 1/16	3/4	2 5/8	1 15/16	1	4,960	4,420	174
TOL330-1-1/8	1 1/8	2 1/2	1 3/16	1	3 3/8	2 3/8	1 1/4	6,230	5,560	373
TOL330-1-1/4	1 1/4	2 1/2	1 3/16	1	3 3/8	2 3/8	1 1/4	8,000	7,140	364
TOL330-1-1/2	1 1/2	2 1/2	1 3/16	1	3 3/8	2 3/8	1 1/4	11,630	10,370	345
TOL330-1-3/4	1 3/4	4	1 1/2	6 1/4	4	2 1/4	15,700	14,000	1,657	
TOL3330-2	2	4	1 1/2	6 1/4	4	2 1/4	20,700	18,460	1,614	
TOL330-2-1/4	2 1/4	4	1 1/2	6 1/4	4	2 1/4	27,200	24,260	1,562	
TOL330-2-1/2	2 1/2	4	1 1/2	6 1/4	4	2 1/4	33,500	29,880	1,506	

Need other hardware?

Call an Edge sales representative today.

Caddy Fasteners Overview

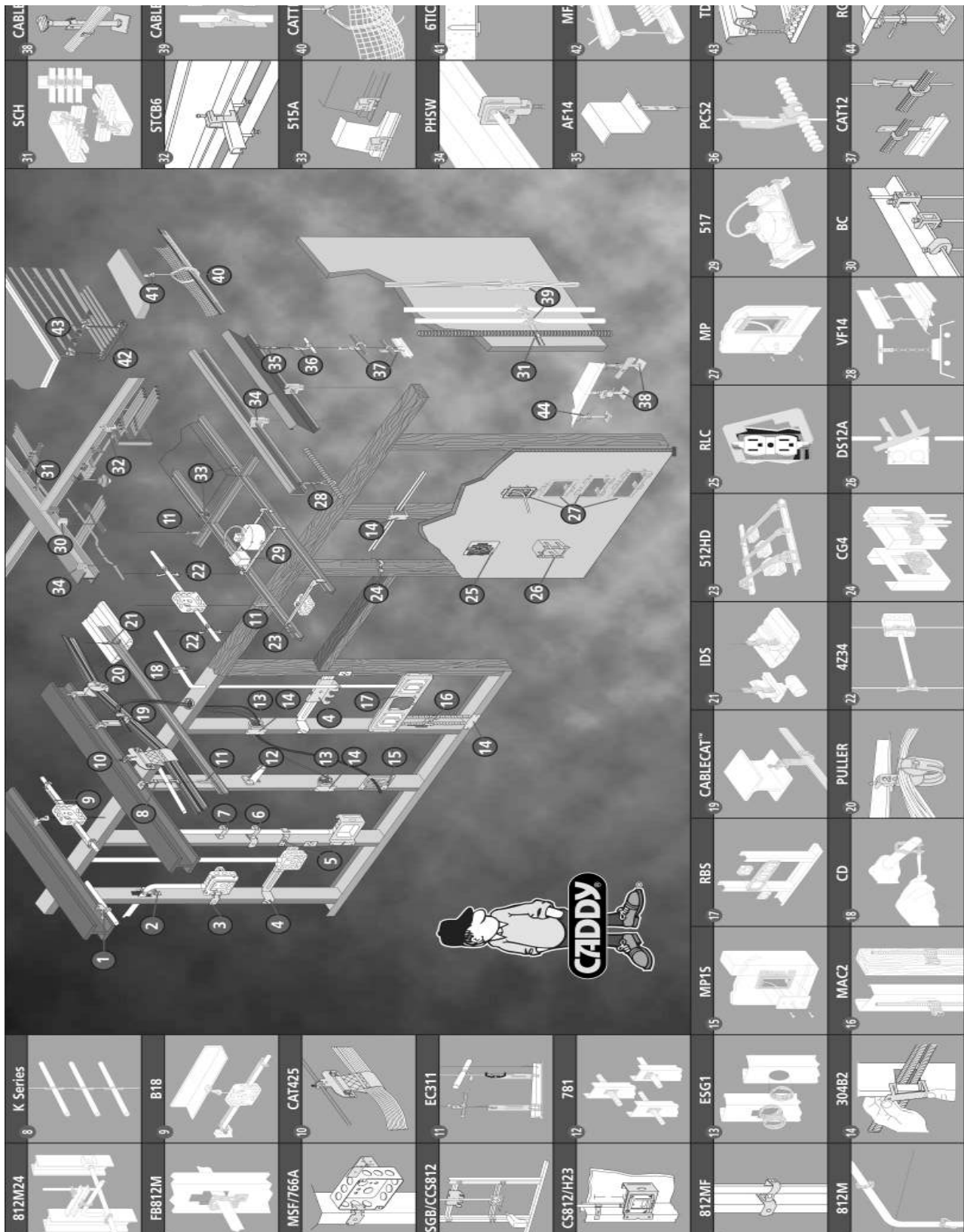

ERICO™

ERICO/ERICO/CADDY One-Piece Strut Clamps



Item #	Size (in.)	Rigid (in.)	Load (lbs.)	Qty. per Box
CASCH8	1/2		200	100
CASCH12	3/4	1/2	200	100
CASCH16	1	3/4	200	100
CASCH20	1 1/4	1	200	100
CASCH12B	3/4	1/2	200	100

ERICO/CADDY Conduit Clips



Item #	Conduit Size	Mounting Hole (in.)
CA6M	For 6M 14-2 thru 12-3 MC/AC and 3/8" Flexible Conduit	3/32 Plain
CA812M4I	1/2" to 3/4"	1/4 - 20 Thread Impression

ERICO/CADDY Screw Gun Box Brackets

Screw gun box bracket for between studs.

- Can mount 1-1/2" or 2-1/8" deep boxes
- Notched and marked for easy identification and bending
- Requires only a screw gun to install

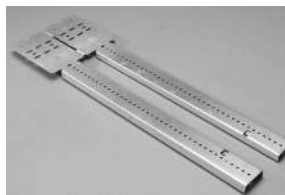

Item #	Stud Spacing (in.)
CASGB16A	16 OC
CASGB24A	24 OC

Preset

Adjustable

CATSGB16	11 to 18
CATSGB24	17 to 26

ERICO/CADDY Flange Mount Conduit Clips

360° Pivot

- Available with Caddy conduit clip bottom mounted or side mounted
- Available for 3/8" thru 2" EMT, rigid and aluminum conduit
- Requires only hammer and pliers to install
- Will pivot thru 360°



Item #	Desc.	Qty. per Box	Load (lbs.)
CA812M24	1/2" to 3/4" Conduit to 1/8" to 1/4" Flanges	100	75
CA16M24	1" Conduit to 1/8" to 1/4" Flanges	100	75
CA16M58	1" Conduit to 5/16" to 1/2" Flanges	100	75
CA20M24	1 1/4" Conduit to 1/8" to 1/4" Flanges	100	75
CA812M24SM	1/2" to 3/4" Conduit to 1/8" to 1/4" Flanges	100	25
CA16M24SM	1" Conduit to 1/8" to 1/4" Flanges	100	25

ERICO/CADDY Hammer-On Flange Clips

- Locates a "portable" 1/4" hole with just a hammer
- Installs easily regardless of insulation materials on beam flange
- Fits most beams and bulb tees
- Qty. per Box: 100



Item #	Flange Thickness (in.)
CA2H4	3/32-9/64
CA4H24	1/8-1/4
CA4H58	5/16-1/2

ERICO/CADDY Hammer-On Flange Clips

Item #	Flange Thickness (in.)
CAM24	1/8-1/4
CAM58	5/16-1/2
CAM24S	1/8-1/4
CAM58S	5/16-1/2





ERICO

ERICO/CADDY

Light Fixture Support Clips

Item #	Desc.
CA515A	Upturned or Straight Lip Fixtures



ERICO/CADDY

Light Fixture Independent Support Clips

Item #	Grid Size (in.)	Stud Length (in.)
CAIDS	1 ⁵ / ₁₆	5/8



ERICO/CADDY
Purlin Clips



Item #	Desc.	Qty. per Box/Kit
CAAF14	1/16" to 1/4" Z Purlin for Wrap Wire, "S" Hooks, Bolting Straps, WMX6	100

ERICO/CADDY
Purlin Clips



Item #	Desc.
CA1226TI	For 3/8" Threaded Rod to Z Purlin

ERICO/CADDY
**Combination Box/
Conduit Hangers**

- Combination box/conduit hanger from drop wire/rod and beam



Item #	Desc., Mounts 4 in. Sq. Boxes with
CA812MB18	1/2" & 3/4" Conduit from #12 Wire thru 1/4" Rod

ERICO/CADDY

Plain and Threaded Rod Hangers

Hammer-On

- Beam clamps
- Static load limit 200 lbs.
- Qty. per Box: 100

Item #	Flange Thickness (in.)	Rod Size
CA6TI24	1/8-1/4	3/8" Threaded
CA6TI58	5/16-1/2	3/8" Threaded



ERICO/CADDY

Protection Plates

Press-On

- Press-on protection plate for woods and metal studs

Item #
CA304B2



ERICO/CADDY

Pipe Sleeve Positioners

- Provides secure positioning of pipe sleeve for concrete pouring of wall and floor forms
- Requires only a hammer to install
- Will accommodate schedule #40, #80 and smaller wall thickness
- No load rating - positioning only
- Sleeve Diameter: All diameters, wall thickness: 5/16 in. and under
- Qty. per box: 100



Item #
CA740

ERICO/CADDY

Conduit Supports

Support and Anti-Rattle

- For conduit armored cable
- Supports and anti-rattle
- Supports conduit up to 1 in.

Item #	Qty./Box
CA781	100



ERICO

ERICO/CADDY

Cable/Conduit Supports

- Cable/conduit from drop wire support



Item #	Desc.	Qty./Box
CAPCS2	Conduit/Cable Support from #8 - #12 Drop Wire for 1/2" and 3/4" EMT, MC/AC up to .900 O.D.	100

ERICO/CADDY

Cable Support Clips

- cULus® Listed and complies with NEC® and TIA requirements for structured cabling systems
- Cost-effective alternative to expensive cable tray
- Galvanized finish on J-hooks provide smoother cable pull and greater corrosion resistance.
- Many sizes and designs available to attach to a variety of structures
- Provides proper support of Category 5e, Category 6a, fiber optic and innerduct
- Diameter Loop



Item #
CACAT32AB

ERICO/CADDY

3/4" Pipe Clip

- Bolt Size: 1/4"
- Conduit Size: EMT 3/4 in
- Conduit Size: Rigid 3/4 in
- Finish: Electro-zinc plated
- Rec. Load: 250 lbs
- Third Party Certifications: cUL®, UL®



Item #
CACD1B

ERICO/CADDY

Metal Stud Grommet

- Snap one grommet into standard 1-11/32" field punched hole, OR snap tight two together into any shape factory punched hole
- Provides 360° protection for cable and makes cable pulls easier
- Delivers compliance with: NEC® Article 300.4(b)(1) and CEC Rule 12-516

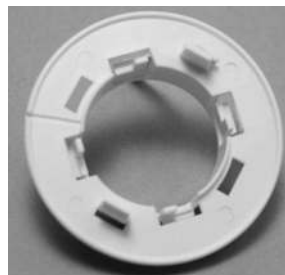

Item #
CAESG1

ERICO/CADDY

Mounting Plate Bracket

Single Gang to Drywall

- Eliminates the need for an electrical box when installing low voltage Class 2 wiring
- Install with a drywall saw and screwdriver
- Makes wire "fishing" easier
- Mounts any standard low voltage device in 1/2" through 1 1/4" walls
- Provides positive support with locking screws (included)

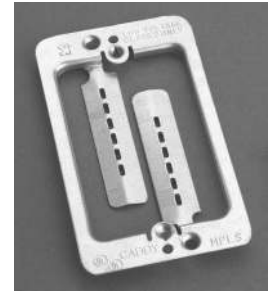

Item #
CAMPLS

ERICO/CADDY

One Piece Strut Clamp

- One size fits both EMT conduit and Rigid pipe sizes
- One-piece break apart design includes captive combo head machine screw and built-in nut (thread impression)
- Surface finish: electro zinc plated



Item # Size (in.)
CASK125I 3/4

ERICO/CADDY

Conduit Hangers

Item #	Conduit Size	Desc.
CAK8	1/2" EMT	#10 and #12 Wire
CAK12	3/4" EMT	#10 and #12 Wire
CAK16	1" EMT	#8 and #9 Wire
CAK20	1 1/4" EMT	#8 and #9 Wire
CAKX	14-2 (.433-.475 O.D.)	#12 Wire



ERICO/CADDY

Strap Hanger Clips

Air Duct Support

- Simple solution for supporting of air duct
- Accepts wider strap widths up to 1-1/4"

Item #	Flange Thickness (in.)
CAMSS24	1/8 to 1/4
CAMSS58	5/16 to 1/2
CAMSR24	1/8 to 1/4
CAMSR58	5/16 to 1/2





ERICO/CADDY
T-Grid Box Hangers

Height Adjustable



Item #	Desc.	Qty. per Box
CA512HD	Heavy-Duty Electrical Box Hanger with Box Mounting Clip - 24" Span	25

ERICO/CADDY
Rod and Wire Hangers

- Qty. per box: 100

Item #	Desc.
CA4TIB	For 1/4" Threaded Rod, with Thread Impression
CA6TIB	For 3/8" Threaded Rod, with Thread Impression
CA6TB	For 1/4" or 3/8" Threaded Rod, Nuts Required



ERICO/CADDY
Wire Hangers

- AB, AO - Permits wire or chain drops from concrete or wood
- Static Load Limit: 160 lbs.
- Qty. per Box: 100

Item #	Desc.
CAAB	Angle Bracket w/ 1/4" Hole



ERICO/CADDY
Wire Hangers

- 6T1 - Rod hanger available for 3/8" threaded rod with or without thread impression
- Static Load Limit: 160 lbs.
- Qty. per Box: 100



Item #	Desc.
CA6T1	For 3/8" Threaded Rod with Thread Impression

ERICO/CADDY
Rooftop Pipe Support Caddy®

- Supports up to 50 lb. loads

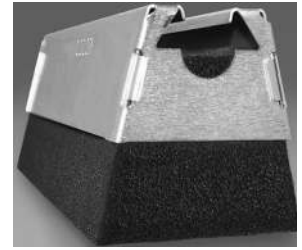

Item #	Height (in.)	Width (in.)	Desc.
CARPS50H4EG	4	10 3/8" x 4" footprint	
CARPS50H6EG	6	5	10 3/8" x 4 3/4"



OREGON WIRE PRODUCTS
Acoustical Ceiling Wire

- 12 gauge acoustical ceiling suspension wires for drop ceilings
- Other gauges available
- Call to specify length
- Call to inquire about other loop or anchor styles



Item #
Ramset SDC125 1-1/4" Pin and Angle

HFPTXXXX

Straightwire

HFSWXXXX

**Edge cuts and
assembles strut.**

**Need it quick? Call
Edge today.**



- Typical grades available are either Grade 2 or A.
- Typical finish is zinc plated.
- Other material and sizes available -- Edge has stock or can source many other hardware products, sizes, materials, finishes, and grades.
- Inquire at Edge about the following options.
 - J-bolt, cut studs, specialty nuts, . . .
 - Almost any size is available upon request. Diameters range from smaller than 1/4" to larger than 1"
 - Materials include carbon steel, stainless steel, fiberglass, and others.
 - Finishes include plain, zinc, hot-dip galvanized, . . .
 - A variety of grades/specifications are available, including Grade A, Grade 2, Grade 5, Grade 8, . . .
- Domestic hardware is available. Even though much of our standard stock is not domestic, Edge can source most every product domestically. Call with your requirements today.
- Material certifications are available upon request. These requests must be made prior to ordering product, otherwise they may not be available.
- Edge can cut all-thread to specified lengths.





Hex Bolts Coarse Thread(NC)

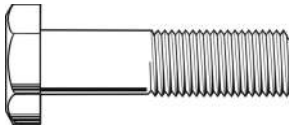

- Inquire about different grades, materials, and finishes

Item #	Desc.	Box Qty.
--------	-------	----------

1/4-20 -- NC

AL10004	1/4-20X1/2	100
AL10006	1/4-20X3/4	100
AL10008	1/4-20X1	100
AL10010	1/4-20X1 1/4	100
AL10012	1/4-20X1 1/2	100
AL10016	1/4-20X2	100
AL10018	1/4-20X2 1/4	100
AL10020	1/4-20X2 1/2	100
AL10024	1/4-20X3	100
AL10028	1/4-20X3 1/2	100
AL10032	1/4-20X4	100
AL10036	1/4-20X4 1/2	100
AL10040	1/4-20X5	100
AL10044	1/4-20X5 1/2	100
AL10048	1/4-20X6	100
AL10056	1/4-20X7	100

5/16-18--NC

AL10078	5/16-18X3/4	100
AL10080	5/16-18X1	100
AL10082	5/16-18X1-1/4	100
AL10084	5/16-18X1-1/2	100
AL10088	5/16-18X2	100
AL10092	5/16-18X2-1/2	100
AL10096	5/16-18X3	100
AL10100	5/16-18X3-1/2	50
AL10104	5/16-18X4	50
AL10108	5/16-18X4-1/2	50
AL10112	5/16-18X5	50
AL10116	5/16-18X5-1/2	50
AL10120	5/16-18X6	50

3/8-16--NC

AL10148	3/8-16X1/2	100
AL10150	3/8-16X3/4	100
AL10152	3/8-16X1	100
AL10154	3/8-16X1 1/4	100
AL10156	3/8-16X1-1/2	100

Item #	Desc.	Box Qty.
AL10158	3/8-16X1 3/4	100
AL10160	3/8-16X2	100
AL10162	3/8-16X2 1/4	50
AL10164	3/8-16X2 1/2	50
AL10168	3/8-16X3	50
AL10172	3/8-16X3 1/2	50
AL10176	3/8-16X4	50
AL10180	3/8-16X4 1/2	50
AL10184	3/8-16X5	50
AL10188	3/8-16X5 1/2	50
AL10192	3/8-16X6	50
1/2-13--NC		
AL10328	1/2-13X1	50
AL10330	1/2-13X1 1/4	50
AL10332	1/2-13X1 1/2	50
AL10336	1/2-13X2	50
AL10340	1/2-13X2 1/2	50
AL10344	1/2-13X3	50
AL10348	1/2-13X3 1/2	25
AL10352	1/2-13X4	25
AL10356	1/2-13X4 1/2	25
AL10360	1/2-13X5	25
AL10364	1/2-13X5 1/2	25
AL10368	1/2-13X6	25
AL10372	1/2-13X6 1/2	25
AL10376	1/2-13X7	25
AL10380	1/2-13X7 1/2	25
AL10384	1/2-13X8	25
AL10392	1/2-13X9	25
AL10400	1/2-13X10	25
AL10416	1/2-13X12	25
5/8-11--NC		
AL10496	5/8-11X1	25
AL10500	5/8-11X1 1/2	25
AL10502	5/8-11X1 3/4	25
AL10504	5/8-11X2	25
AL10508	5/8-11X2 1/2	25
AL10512	5/8-11X3	25
AL10516	5/8-11X3 1/2	25
AL10520	5/8-11X4	25
AL10524	5/8-11X4 1/2	25
AL10528	5/8-11X5	25
AL10532	5/8-11X5 1/2	25
AL10536	5/8-11X6	25
AL10540	5/8-11X6 1/2	25
AL10544	5/8-11X7	25
AL10552	5/8-11X8	25

Item #	Desc.	Box Qty.
AL10556	5/8-11X8 1/2	20
AL10560	5/8-11X9	20
AL10568	5/8-11X10	20
AL10584	5/8-11X12	20
3/4-10--NC		
AL10664	3/4-10X1	20
AL10670	3/4-10X1 1/2	20
AL10674	3/4-10X2	20
AL10682	3/4-10X3	20
AL10686	3/4-10X3 1/2	20
AL10690	3/4-10X4	20
AL10694	3/4-10X4 1/2	20
AL10698	3/4-10X5	20
AL10702	3/4-10X5 1/2	20
AL10710	3/4-10X6 1/2	20
AL10714	3/4-10X7	20
AL10718	3/4-10X7 1/2	20
AL10722	3/4-10X8	20
AL10730	3/4-10X9	20
AL10738	3/4-10X10	20
AL10746	3/4-10X11	15
AL10754	3/4-10X12	15
AL10770	3/4-10X14	10
7/8-9--NC		
AL10904	7/8-9X4 1/2	10
AL10908	7/8-9X5	10
AL10916	7/8-9X7	10
AL10924	7/8-9X7	10
1-8--NC		
AL11052	1-8X4	10
AL11060	1-8X5	10
AL11076	1-8X7	10
AL11092	1-8X9	10

Hanger Bolts

Plain Finish



Item #	Desc.	Box Qty.
AL19232	1/4-20X2	100
AL19236	1/4-20X2 1/2	100
AL19240	1/4-20X3	100
AL19302	3/8-16X3	100
AL19306	3/8-16X3 1/2	100

All Thread



- Standard lengths vary-ask our experts
- Inquire about different grades, materials, and finishes
- Let us know if you need to meet a special spec., domestic requirement, or need material certifications
- Ask about studs, custom cut lengths
- ITEMS IN CHART BELOW ARE MOST COMMON ITEMS

Item #	Size	Finish
AT14Z	1/4-20	Zinc
AT38B	3/8-16	Black
AT38Z	3/8-16	Zinc
AT38Z-12'	3/8-16x12'	Black
AT12B	1/2-13	Black
AT12Z	1/2-13	Zinc
AT12Z-12'	1/2-13x12'	Zinc
AT58B	5/8-11	Black
AT58HDG	5/8-11	Hot Dip Galv
AT58Z	5/8-11	Zinc
AT34B	3/4-10	Black
AT34Z	3/4-10	Zinc
AT78HDG	7/8-9	Hot Dip Galv
AT78Z	7/8-9	Zinc
AT1Z	1-8	Zinc

Lag Bolts

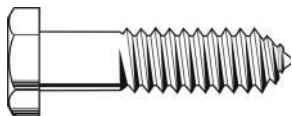

- Inquire about different grade, materials, and finishes

Item #	Desc.	Box Qty.
Diameter 1/4		
AL12510	1/4X1 1/4	100
AL12512	1/4X1 1/2	100
AL12516	1/4X2	100
AL12520	1/4X2 1/2	100
AL12524	1/4X3	100
AL12528	1/4X3 1/2	100
AL12536	1/4X4 1/2	100
AL12540	1/4X5	100
AL12544	1/4X5 1/2	100
Diameter 5/16		
AL12568	5/16X1 1/2	100
AL12572	5/16X2	100

Item #	Desc.	Box Qty.
AL12576	5/16X2 1/2	100
AL12588	5/16X4	50
Diameter 3/8		
AL12620	3/8X1	100
AL12622	3/8X1 1/4	100
AL12624	3/8X1 1/2	100
AL12628	3/8X2	100
AL12632	3/8X2 1/2	50
AL12636	3/8X3	50
AL12640	3/8X3 1/2	50
AL12644	3/8X4	50
AL12648	3/8X4 1/2	50
AL12652	3/8X5	50
AL12656	3/8X5 1/2	50
AL12660	3/8X6	50

Diameter 1/2

AL12712	1/2X1 1/2	50
AL12716	1/2X2	50
AL12720	1/2X2 1/2	50
AL12724	1/2X3	50
AL12728	1/2X3 1/2	25
AL12732	1/2X4	25
AL12736	1/2X4 1/2	25
AL12740	1/2X5	25
AL12744	1/2X5 1/2	25
AL12748	1/2X6	25

Diameter 5/8

AL12828	5/8X3	25
AL12832	5/8X3 1/2	25
AL12836	5/8X4	25
AL12844	5/8X5	25
AL12852	5/8X6	25

Hex Nuts

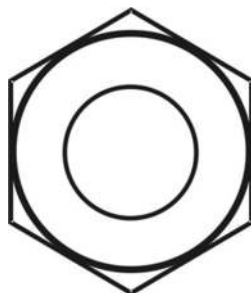

- Inquire about different grades, materials, and finishes

Item #	Desc.	Box Qty.
AL30004	1/4-20	100

Item #	Desc.	Box Qty.
AL30005	5/16-18	100
AL30006	3/8-16	100
AL30008	1/2-13	50
AL30010	5/8-11	25
AL30012	3/4-10	20
AL30014	7/8-9	15
AL30016	1-8	10
AL30020	1 1/4-7	10

Nylon Insert Lock Nuts

Coarse Thread (NC)



- Inquire about different grades, materials, and finishes

Item #	Desc.	Box Qty.
AL30452	3/8-16	100
AL30454	1/2-13	50
AL30456	5/8-11	25
AL30458	3/4-10	50

Coupling Nuts

Coarse Thread (NC)



- Inquire about different grades, materials, and finishes

Item #	Desc.	Box Qty.
AL30853	1/4-20	50
AL30855	3/8-16	50
AL30856	3/8-1/4 Reducer	50
AL30857	1/2-13	50
AL30858	1/2-3/8 Reducer	25
AL30859	5/8-11	20
AL30861	3/4-10	20
AL30862	7/8-9	10
AL30863	1"-8	10



Fender Washers

- Inquire about different grades, materials, and finishes

Item #	Desc.	Box Qty.
AL31693	3/16X1 1/4	100
AL31707	1/4X1	100
AL31709	1/4X1 1/4	100
AL31711	1/4X1 1/2	100
AL31749	3/8X1 1/4	100
AL31751	3/8X1 1/2	100
AL31759	1/2X1 1/2	100
AL31763	1/2X2	100

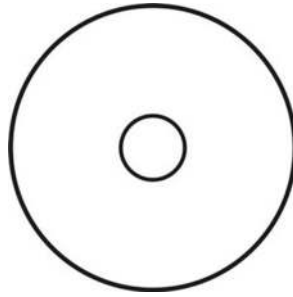

Split Lock Washers

- Inquire about different grades, materials, and finishes

Item #	Desc.	Box Qty.
AL31301	#10 3/16	100
AL31302	1/4	100
AL31303	5/16	100
AL31304	3/8	100
AL31306	1/2	100
AL31308	5/8	100
AL31310	3/4	100
AL31312	7/8	100
AL31314	1"	100
AL31320	#12	100
AL31323	#8	100

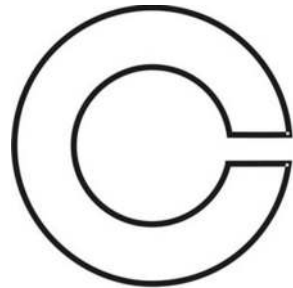

Flat Washers

- Inquire about different grade, materials, and finishes

Item #	Desc.	Box Qty.
AL31026	3/16 (#10)	100
AL31027	1/4 (#14)	100
AL31028	5/16	100
AL31029	3/8	100
AL31031	1/2	100
AL31033	5/8	50
AL31035	3/4	25
AL31037	7/8	25
AL31039	1"	25
AL31095	#12	100
AL31097	#6	100
AL31098	#8	100

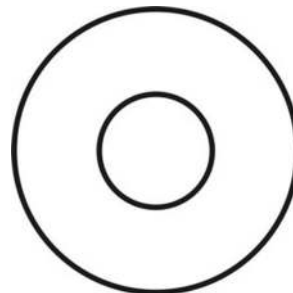

Edge stocks or can get more hardware than shown in this catalog

Need Stainless Steel? Give us a call!

Ask about our Never-Out-Of-Stock (NOS) box program



SIMPSON STRONG-TIE® Epoxy-Tie® Adhesive Dispensing Tool

- Each tool has been designed to work with Epoxy-Tie® cartridges for trouble-free dispensing
- These tools are for use with SET, SET-XP™, EDOT™, ET, ETI adhesives and CIP and CIP-F paste-over material



Item #	Description
SNC DT10	Premium Tool for Single Cartridges
SNEDT22B	Manual Tool for 22 oz. Cartridges
SNEDT22CKT	Battery Powered Tool for 220 oz. Cartridges
SNEDT22AP	Pneumatic Tool for 22 oz. Cartridges
SNEDT56AP	Pneumatic Tool for 56 oz. Cartridges
SNEDT22S	Manual Tool for twin 300 ml Cartridges or 300/150 ml Cartridges



Simpson Strong-Tie® High Strength Epoxy-Tie Anchor System

SET-XP®



- CRACKED CONCRETE APPROVED
- SET-XP®, the popular epoxy-based anchoring adhesive formulated for optimum performance in both cracked and uncracked concrete, is now available in a 56 oz. cartridge for larger-volume jobs. Rigorously tested in accordance with ICC-ES AC308 2006 and 2009 IBC requirements, and proven to deliver increased reliability in the most adverse conditions, SET-XP provides greater convenience coupled with unmatched performance. This non-shrink epoxy anchoring adhesive meets the requirements of ASTM C881 specification for Type I and Type IV, Grade 3, Class C epoxy.
- Uses: When SET-XP® adhesive is used with threaded rod, rebar or the IXP™ anchor, the system can be used in tension and seismic zones where there is a risk of cracks occurring that pass through the anchor location. It is also suitable for uncracked concrete conditions
- Codes: ICC-ES ESR-2508; City of L.A. RR25744; Florida FL 11506.5 NSF/ANSI Standard 61 (216 in./gal).
- Shelf life: 24 months from date of manufacture in unopened side-by-side cartridge
- Cure Schedule (Base Material Temp° / Cure Time hrs.): 50/72, 70/24, 90/24, 110/24

Item #	Capacity (oz.)	Cartridge Type	Ctn Qty.	Dispensing Tool(s)	Mixing Nozzle
SNSET-XP22	22	Side-by-Side	10	EDT22B, EDT22AP, EDT22CKT, EDT22S	EMN22i
SNSET-XP56	56	Side-by-Side	56	EDT56AP	EMN22i

SIMPSON STRONG-TIE® Epoxy Anchor Cartridge

High Strength SET



- Epoxy-Tie SET epoxy is a two-component, low odor, 1:1 ratio, 100% solids epoxy-based adhesive for use as a high strength, non-shrink anchor grouting material
- Resin and hardener are dispensed and mixed simultaneously through the mixing nozzle. SET meets or exceeds the ASTM C-881 specification for Type I, II, IV and V, Grade 3, Class B and C
- USES: Threaded rod anchoring, Rebar dowelling, Bonding hardened concrete to hardened concrete, Pick proof sealant around doors, windows and fixtures, Paste-over for crack injection
- Code Approvals: ICC-ES ESR-1772 (CMU & URM); City of L.A. RR25279; Florida FL 11506.4; Caltrans approved; multiple DOT listings; NSF/ANSI Standard 61 (216 in2/1000 gal), except SET1.7KTA. SET-PAC-EZ™ adhesive covered by ICC-ES, City of L.A. and NSF/ANSI listings only
- SHELF LIFE: 24 months from date of manufacture in unopened side-by-side cartridge. SET-PAC-EZ™ cartridge - 24 months from date of manufacture, unopened

Item #	Capacity (oz.)	Cartridge Type	Carton Qty	Dispensing Tool(s)	Mixing Nozzle	UoM
SNSET1.7KTA	1.7	Side-by Side	12	Adapter Included for Standard Caulking Tool	EMN1.7 (2 included)	Ea
SNSET-PAC-EZ	8.5	Single	12	CDT10 or High Quality Standard Caulking Tool	2 Included	
SNSET22	22	Side-by Side	12	CDT10 or High Quality Standard Caulking Tool	EMN22i	Ea
SNSET56	56	Side-by Side	6	EDT56AP	EMN22i, EMN50	Ea



SIMPSON STRONG-TIE®

High Strength Acrylic-Tie® Anchoring Adhesive AT-XP™

Acrylic-Tie® AT-XP™ anchoring adhesive is specifically formulated for fast curing and delivers optimum performance anchoring threaded rod and dowels in uncracked concrete

- AT-XP adhesive blends high strength with EASY COLD WEATHER DISPENSING and excellent reduced-temperature performance to provide a complete adhesive anchoring solution
- Rigorously tested in accordance with ICC-ES AC308 and IBC 2009 requirements for uncracked concrete, reduced-temperature testing results have shown AT-XP adhesive to dispense easily with no load reductions in substrate temperatures as low as 14°F (-10°C)
- AT-XP is a two-component, high-solids, 10:1 ratio acrylic-based adhesive for use as a high strength, anchor-grouting material. Resin and initiator are dispensed and mixed simultaneously through the mixing nozzle
- USES: Threaded rod anchoring in concrete, rebar doweling in concrete
- CODES: ICC-ES evaluation report pending
- SHELF LIFE: Nine months from date of manufacture in unopened cartridge
- Cure Schedule (Base Material Temp° / Cure Time hrs.): 14/24, 32/8, 50/3, 68/1



Item #	Capacity (oz.)	Cartridge Type	Carton Qty	Dispensing Tool(s)	Mixing Nozzle
SNAT-XP13	13	Side-by-Side	10	ADT813	AMN19Q
SNAT-XP30	30	Side-by-Side	5	ADT30S, ADT30P, ADT30CKT	EMN22i

SIMPSON STRONG-TIE®

High Strength Acrylic-Tie® Anchoring Adhesive AT

- AT Acrylic-Tie® is a two component, high solids, 10:1 ratio acrylic-based adhesive for use as a high strength, anchor-grouting material
- Formulated for use in all types of weather, AT is designed to dispense easily and cure at temperatures down to 0°F
- Resin and initiator are dispensed and mixed simultaneously through the mixing nozzle. AT meets the physical requirements of ASTM C881, Type I & IV, Grade 3, Classes A, B & C, except Acrylic-Tie is a non-epoxy product formulated for fast cure time
- USES: Threaded rod anchoring, rebar doweling, pick-proof sealant around doors, windows and fixtures
- Code Approvals: ICC-ES ER-5791* (CMU & URM); City of L.A. RR25459*; Florida FL 11506.1*; NSF/ANSI Standard 61 (11 in2/5000 gal); Multiple DOT listings
- SHELF LIFE: 12 months from date of manufacture in unopened cartridge
- Cure Schedule (Base Material Temp° / Cure Time hrs.): 0/24, 40/4, 70/.5



Item #	Capacity (oz.)	Cartridge Type	Ctn Qty.	Dispensing Tool(s)	Mixing Nozzle
SNATPAC05KT	5	Coaxial	12	CDT10 or Standard 10 oz. Single Tube Dispensing Tool	AMN813 (Included)
SNAT08	8	Side-by Side	10	ADT813B	AMN813 (Included)
SNAT10	9.6	Single	12	CDT10 or Standard 10 oz. Single Tube Dispensing Tool	AMN813 (Included)
SNAT13	13	Side-by Side	10	ADT813B	AMN813 (Included)
SNAT30	30	Side-by Side	5	ADT30, ADT30P, ADT30CKT	EMN22i (Sold Separately)

SIMPSON STRONG-TIE®

Acrylic-Tie® Adhesive Dispensing Tools

Item #	Description
SNADT813B	Manual Tool for 8 oz. and 13 oz. Cartridges
SNADT30	Manual Tool for 30 oz. Cartridges
SNADT30CKT	Battery Powered Tool for 30 oz. Cartridges
SNADT30P	Pneumatic Tool for 30 oz. Cartridges





SIMPSON STRONG-TIE®
Mixing Nozzles and Retaining Nuts



- Mixing nozzles are designed for the proper proportioning and mixing of the different adhesive formulations
- EMN37A - This is an 18 element mixing nozzle for Epoxy-Tie adhesives and for use with the 30oz. Acrylic-Tie cartridge. This nozzle requires a separate nozzle retaining nut to attach to the cartridge
- EMN2256 - Retaining nuts for the EMN37A.
- EMN50 - This is a Hi-Volume 5/8" diameter 24 element nozzle, with an integrally molded retaining nut. This nozzle provides approximately 2 times the dispensing rate of the EMN37A. The major outer diameter is 7/8". Fits 22 oz., 30 oz. and 56 oz. SBS cartridges.
- AMN813-RP5 - This is a package of 5, 12 element mixing nozzles with integrally molded retaining nut for use with 8oz. and 13oz. Acrylic-Tie only.

Item #	Description	Pkg Qty
SNEMN37B	Mixing Nozzle Only, 14 in. Long, Major Diameter 5/8 in.	
SNENN2256	Retaining Nuts Only for the EMN37 (Orange)	
SNEMN50	Hi-Volume Nozzle for 22oz, 30oz and 56oz SBS Cartridges (Separate Retaining Nut not Required), 17 in. Long, Major Diameter 7/8 in.	
SNAMN813-RP5	Five Mixing Nozzles for 8oz and 13oz SBS Acrylic-Tie Cartridges Only, 8 1/2 in. Long Flush Mounted Injection Port Corner Mount Injection Port	5

SIMPSON STRONG-TIE®
Adhesive Retaining Caps

Adhesive retaining caps make overhead and horizontal installation easier by preventing the adhesive from running out of the hole. They also center the rod in the hole, making them ideal for applications where precise anchor placement is required. It may be necessary to provide support for the insert during cure time. Adhesive retaining caps are not designed to support the weight of the insert in overhead installations.



Item #	For Rod Dia. (in.)	Required Hole Diameter (in.)	Cap Depth (in.)	Pkg. Qty.
Adhesive Retaining Caps For Epoxy Tie				
SNARC37-RP25	3/8	1/2	7/16	25
SNARC50-RP25	1/2	5/8	1/2	25
SNARC62-RP25	5/8	3/4	9/16	25
SNARC75-RP25	3/4	7/8	9/16	25
SNARC87-RP25	7/8	1	1 1/16	25
SNARC100-RP25	1	1 1/8	1 1/16	25
SNARC125-RP25	1 1/4	1 3/8	7/8	25
Adhesive Retaining Caps For Acrylic-Tie				
SNARC37A-RP25	3/8	7/16	25	
SNARC50A-RP25	1/2	9/16	1/2	25
SNARC62A-RP25	5/8	1 1/16	9/16	25
SNARC75A-RP25	3/4	1 3/16	9/16	25
SNARC87A-RP25	7/8	1	1 1/16	25
SNARC100A-RP25	1	1 1/16	1 1/16	25
SNARC125A-RP25	1 1/4	1 3/8	7/8	25



SIMPSON STRONG-TIE®
Hole Cleaning Brushes



- Brushes are used for cleaning drilled holes prior to adhesive anchor installation. Brushes have a twisted wire handle with nylon bristles

Item #	Description	For Anchor/Rebar Diameter (in.)	For Hole Diameter (in.)
SNETB4	1/2"x3" brush (8" total length)	1/4-5/16	3/8-7/16
SNETB6	3/4"x4" brush (16" total length)	3/8-5/8	1/2-3/4
SNETB8	1"x4" brush (16" total length)	3/4	13/16-7/8
SNETB8L	1"x4" brush (24" total length)	3/4	13/16-7/8
SNETB10	1 1/4"x4" brush (29" total length)	7/8-1	1-1 1/8
SNETB12	1 5/8"x6" brush (34" total length)	1 1/4	1 3/16-1 3/8

SIMPSON STRONG-TIE®
**Opti-Mesh® Epoxy-Tie®
Adhesive-Anchoring Screen
Tubes**



- Screen tubes are tested and written into many code reports-make sure to use as recommended
- Screen tubes are vital to the performance of adhesive anchors in base materials that are hollow, or contain voids, such as hollow block and brick. The Simpson Strong-Tie®
- Opti-Mesh® screen tube provides the economical advantage of a plastic screen tube while providing performance comparable to steel screen tubes and better than competitive plastic screen tubes

Caution: Screen tubes are designed for a specific adhesive type. Epoxy-Tie® screen tubes must be used with SET or ET formulations and Acrylic-Tie® screen tubes must be used with AT Acrylic-Tie® adhesive. Do not use SET1.7KT or SET1.7KTA with screen tubes

Item #	For Rod Dia.	Hole Size	Screen Length (in.)
SNETS506P	1/2	3/4	6
SNETS5010P	1/2	3/4	10
SNETS626P	5/8	7/8	6
SNETS6210P	5/8	7/8	10
SNETS6213P	5/8	7/8	13
SNETS758P	3/4 in.	1 in.	8
SNETS7513P	3/4 in.	1 in.	13
SNETS7517P	3/4 in.	1 in.	17

SIMPSON STRONG-TIE®
**Self-Undercutting Anchor for
Cracked or Un-cracked Concrete**
Torq-Cut™



- The Torq-Cut™ self-undercutting anchor is a heavy-duty, high-capacity anchor designed and tested for use in CRACKED AND UNCRACKED concrete under static and seismic loading conditions. It is designed to meet the stringent requirements of the 2006 and 2009 IBC for post-installed anchors
- The built-in ring with hardened cutters expands with installation torque forming undercut grooves in the concrete. This interlocking connection between the anchor and the concrete provides superior load carrying capacity
- FINISH: Zinc plated
- CODES: ICC-ES pending

TEST CRITERIA: The Torq-Cut anchor has been tested in accordance with ICC-ES's Acceptance Criteria for Mechanical Anchors in Concrete Elements (AC193) and ACI 355.2 for the following:

- Static tension and shear loading in cracked and uncracked concrete
- Seismic and wind loading in cracked and uncracked concrete
- Performance in cracked concrete

Item #	Size (in.)	Drill Bit Dia. (in.)	Box Qty.
SNTCAP370600	3/8X6	5/8	10
SNTCAP500834	1/2X8 3/4	7/8	5
SNTCAP500912	1/2X9 1/2	7/8	5
SNTCAP621112	5/8X11 1/2	1	4
SNTCAP621212	5/8X12 1/2	1	4
SNTCAP751458	3/4X14 5/8	1 1/4	4
SNTCAP751658	3/4X16 5/8	1 1/4	4



SIMPSON STRONG-TIE®
Wedge Anchor

Strong-Bolt™ 2



- The Strong-Bolt™ 2 wedge anchor is the next-generation solution for CRACKED AND UNCRACKED concrete
- Following rigorous testing according to ICC-ES acceptance criteria, the Strong-Bolt™ 2 anchor received classification as a Category 1 anchor, the highest attainable anchor category for performance in cracked concrete under static and seismic loading
- Available in stainless steel, it is code-listed by ICC-ES under the 2009 IBC requirements for post-installed anchors in cracked and uncracked concrete
- Finish: Zinc-plated (carbon steel) and stainless steel available
- Code Approvals: ICC-ES ESR-3037 (carbon and stainless steel); City of Los Angeles – Pending; UL – Pending; FM – Pending; Florida – Pending

Item #	Size (in.)	Drill Bit Dia. (in.)	Thread Length (in.)	Box Qty.
Carbon Steel				
SNSTB2-37234	3/8X2 3/4	3/8	1 5/16	50
SNSTB2-37300	3/8X3	3/8	1 9/16	50
SNSTB2-37312	3/8X3 1/2	3/8	2 1/16	50
SNSTB2-37334	3/8X3 3/4	3/8	2 5/16	50
SNSTB2-37500	3/8X5	3/8	3 9/16	50
SNSTB2-37700	3/8X7	3/8	5 9/16	50
SNSTB2-50334	1/2X3 3/4	1/2	2 1/16	25
SNSTB2-50414	1/2X4 1/4	1/2	2 9/16	25
SNSTB2-50512	1/2X5 1/2	1/2	3 13/16	25
SNSTB2-50700	1/2X7	1/2	5 5/16	25
SNSTB2-50812	1/2X8 1/2	1/2	6	25
SNSTB2-50100	1/2X10	1/2	6	25
SNSTB2-62412	5/8X4 1/2	5/8	2 7/16	20
SNSTB2-62500	5/8X5	5/8	2 15/16	20
SNSTB2-62600	5/8X6	5/8	3 15/16	20
SNSTB2-62700	5/8X7	5/8	4 15/16	20
SNSTB2-62812	5/8X8 1/2	5/8	6	20
SNSTB2-62100	5/8X10	5/8	6	10

16 Stainless Steel

SNSTB2-372346SS	3/8X2 3/4	3/8	1 5/16	50
SNSTB2-373006SS	3/8X3	3/8	1 9/16	50
SNSTB2-376126SS	3/8X3 1/2	3/8	2 1/16	50
SNSTB2-373346SS	3/8X 3 3/4	3/8	2 5/16	50
SNSTB2-375006SS	3/8X5	3/8	3 9/16	50
SNSTB2-377006SS	3/8X7	3/8	5 9/16	50

SIMPSON STRONG-TIE®
Wedge Anchor

Strong-Bolt™



- The Strong-Bolt™ is a wedge anchor specifically designed for optimum performance in both CRACKED AND UNCRACKED concrete; a requirement that the 2006 IBC places on post-installed anchors
- Rigorously tested according to the latest industry-wide criteria, the Strong-Bolt anchor is proven to offer increased reliability in the most adverse conditions, including performance in cracked concrete under static and seismic loading
- The proprietary tri-segmented clip has dual undercutting embossments on each segment which enable secondary or "follow-up" expansion if a crack forms and intersects the anchor location. This significantly increases the ability of the Strong-Bolt wedge anchor to carry load if the hole opened slightly due to a crack. The Strong-Bolt anchor sets like a standard wedge anchor and is available in Imperial fractional sizes
- FINISH: Zinc plated
- Code Approvals: ICC-ES ESR-1771; City of L.A. RR25705; Florida FL 11506.6

Item #	Size (in.)	Drill Bit Dia. (in.)	Thread Length (in.)	Box Qty.
SNSTB50334	1/2X3 3/4	1/2	2 5/16	25
SNSTB50414	1/2X4 3/4	1/2	2 13/16	25
SNSTB50512	1/2X5 1/2	1/2	4 1/16	25
SNSTB50700	1/2X7	1/2	5 9/16	25
SNSTB50812	1/2X8 1/2	1/2	6	25
SNSTB50100	1/2X10	1/2	6	25
SNSTB62412	5/8X4 1/2	5/8	2 7/8	20
SNSTB62500	5/8X5	5/8	3 3/8	20
SNSTB62600	5/8X6	5/8	4 3/8	20
SNSTB62700	5/8X7	5/8	5 3/8	20
SNSTB62812	5/8X8 1/2	5/8	6	20
SNSTB62100	5/8X10	5/8	6	10
SNSTB75512	3/4X5 1/2	3/4	3 3/8	10
SNSTB75614	3/4X6 1/4	3/4	4 3/8	10
SNSTB75700	3/4X7	3/4	5 1/8	10
SNSTB75812	3/4X8 1/2	3/4	6	10
SNSTB75100	3/4X10	3/4	6	10
SNSTB100700	1X7	1	3 1/2	5
SNSTB1001000	1X10	1	3 1/2	5
SNSTB1001300	1X13	1	3 1/2	5

**Ask about
"Cracked Concrete"
anchors**



SIMPSON STRONG-TIE®

Heavy Duty Screw Anchor For Concrete and Masonry

TITEN HD®

- The Titen HD® is a patented, high-strength screw anchor for concrete and masonry.
- The self-undercutting, non-expansion characteristics of the Titen HD® makes it the ideal anchor for structural applications, even at minimum edge distances and under reduced spacing conditions.
- The proprietary cutting teeth enable the Titen HD® to be installed in one eighth of the time when compared to traditional expansion anchors, and at significantly reduced installation torques.
- The anchor can be installed with a standard ANSI tolerance drill bit and is removable. Recommended for permanent dry, interior non-corrosive environments or temporary outdoor applications.
- Zinc Plating meetings ASTM B633, SC1
- Mechanical galvanizing meets ASTM B695, Class 65, Type 1. Intended for some pressure-treated wood sill plate applications. Not for use in other corrosive or outdoor environments.



Item #	Size (in.)	Drill Bit Dia. (in.)	Wrench Size (in.)	Box Qty.
--------	-------------	----------------------	-------------------	----------

Zinc Plated

SNTHD37300H	3/8x3	3/8	9/16	50
SNTHD37400H	3/8x4	3/8	9/16	50
SNTHD37500H	3/8x5	3/8	9/16	50
SNTHD50300H	1/2x3	1/2	3/4	25
SMTHD37600H	3/8x6	3/8	9/16	50
SNTHD50400H	1/2x4	1/2	3/4	20
SNTHD50500H	1/2x5	1/2	3/4	20
SNTHD50600H	1/2x6	1/2	3/4	20
SNTHD50612H	1/2x6 1/2	1/2	3/4	20
SNTHD50800H	1/2x8	1/2	3/4	20
SNTHD501200H	1/2x12	1/2	3/4	20
SNTHD501300H	1/2x13	1/2	3/4	20
SNTHD501400H	1/2x14	1/2	3/4	20
SNTHD501500H	1/2x15	1/2	3/4	20
SNTHD62400H	5/8x4	5/8	15/16	10
SNTHD62500H	5/8x5	5/8	15/16	10
SNTHD62600H	5/8x6	5/8	15/16	10
SNTHD62612H	5/8x6 1/2	5/8	15/16	10
SNTHD62800H	5/8x8	5/8	15/16	10
SNTHD75400H	3/4x4	3/4	1 1/8	10
SNTHD75500H	3/4x5	3/4	1 1/8	5

Item #	Size (in.)	Drill Bit Dia. (in.)	Wrench Size (in.)	Box Qty.
SNTHDT75600H	3/4x6	3/4	1 1/8	5
SNTHD75700H	3/4x7	3/4	1 1/8	5
SNTHD75812H	3/4X8 1/2	3/4	1 1/8	5
SNTHD75100H	3/4X10	3/4	1 1/8	5

Mechanically Galvanized

SNTHD37500HMG	3/8x5	3/8	9/16	50
SNTHD37600HMG	3/8x6	3/8	9/16	50
SNTHD50500HMG	1/2x5	1/2	3/4	20
SNTHD50500HMG	1/2x6	1/2	3/4	20
SNTHD50500HMG	1/2x6 1/2	1/2	3/4	20
SNTHD50500HMG	1/2x8	1/2	3/4	20
SNTHD50500HMG	5/8x5	5/8	15/16	10
SNTHD50500HMG	5/8x6	5/8	15/16	10
SNTHD50500HMG	5/8x6 1/2	5/8	15/16	10
SNTHD50500HMG	5/8x8	5/8	15/16	10
SNTHD75182HMG	3/4X8 1/2	3/4	1 1/8	5
SNTHD75100HMG	3/4X10	3/4	1 1/8	5

SIMPSON STRONG-TIE®

Screw Anchor for Concrete and Masonry

TITEN HD® MINI Screw Anchor

- Sharing the same features as the larger Titen HD® screw anchor (page 119), the Titen HD® Mini anchor provides an easy solution for jobs that call for smaller anchors
- The self-undercutting, non-expansion characteristics are ideal for situations where minimum edge distance and reduced spacing is a concern. The patented cutting teeth and thread design enable the Titen HD Mini anchor to be installed quickly and with less effort than many other screw type anchors
- Since there are no secondary setting steps involved, the Titen HD Mini screw anchor can be installed much more quickly than traditional expansion anchors
- FINISH: Zinc plated
- TEST CRITERIA: The Titen HD® Mini anchor has been tested in accordance with ASTM E488 standard test methods for tension and shear.



Item #	Size (in.)	Drill Bit Dia. (in.)	Wrench Size (in.)	Box Qty.
SNTHD25134H	1/4X1 3/4	1/4	3/8	100
SNTHD25214H	1/4X2 1/4	1/4	3/8	50
SNTHD25300H	1/4X3	1/4	3/8	50
SNTHD37134H	3/8X1 3/4	3/8	9/16	50
SNTHD37212H	3/8X2 1/2	3/8	9/16	50



SIMPSON STRONG-TIE®
Threaded Rod Hanger
TITEN HD®



- The Titen HD® rod hanger is a high-strength screw anchor designed to suspend threaded rod from concrete slabs and beams in order to hang pipes, cable tray and HVAC equipment
- Two new designs feature a 3/8" dia. shank which specifically qualifies these models for code listing by ICC-ES for CRACKED AND UNCRACKED concrete applications under the 2006 and 2009 IBC
- Finish: Zinc plated
- Code Approvals: ICC-ES ESR-2713 (THD37212RH and THD50234RH), Factory Mutual 3031136 (THD50234RH and THD37218RH) and 3035761 (THD37212RH)

Item #	Size (in.)	Accepts Rod Dia. (in.)	Drill Bit Dia. (in.)	Wrench Size (in.)	Min. Embed. (in.)	Box Qty.
SNTHD25112RH	¼X1½	¼	⅜	1½	100	
SNTHD37218RH	⅜X2½	⅜	¼	½	2½	50
SNTHD37212RH	⅜X2½	⅜	½	2½	50	
SNTHD50234RH	½X2¾	½	⅜	1½	2¾	50

SIMPSON STRONG-TIE®
Sleeve Anchors
SLEEVE-ALL®



- Sleeve-Alls are pre-assembled expanding sleeve anchors for use in all types of hollow and solid base materials
- These anchors are available in acorn, hex, rod coupler, flat or round head styles for a wide range of applications
- Made of carbon steel with Zinc plating
- Code Approvals: Factory Mutual 3017082, 3026805 and 3029959, 3/8"-3/4" dia.; Underwriters Laboratories File Ex3605, 3/8"-3/4" dia. Meets requirements of Federal Specifications A-A-1922A.

Item #	Part #	Size (in.)	Bolt Dia. Thread (per in.)	Max Material Thickness (in.)	Quantity Box
Acorn Head					
SNSL25214A	SL25214A	¼ x 2¼	⅜-24	1½	100
Hex Head					
SNSL31212H	SL31212H	⅝ x 2½	¼-20	1½	50
SNSL37300H	SL37178H	⅜ x 1⅞	⅝-18	⅜	50
SNSL37300H	SL37300H	⅜ x 3	⅝-18	1½	50
SNSL37400H	SL37400H	⅜ x 4	⅝-18	2½	50
SNSL50300H	SL50300H	½ x 3	⅜-16	¾	25
SNSL50400H	SL50400H	½ x 4	⅜-16	1¾	25
SNSL50600H	SL50600H	½ x 6	⅜-16	3⅜	20
SNSL62414H	SL62414H	⅝ x 4¼	½-13	1½	10
SNSL62600H	SL62600H	⅝ x 6	½-13	3¼	10
SNSL75414H	SL75414H	¾ x 4¼	⅝-11	⅞	10
SNSL75614H	SL75614H	¾ x 6¼	⅝-11	2⅞	5
Flat Head					
SNSL25200PF	SL25200PF	¼ x 2	⅜-24	⅞	100
SNSL25300PF	SL25300PF	¼ x 3	⅜-24	1⅞	50
SNSL31312PF	SL31312PF	⅝ x 3½	¼-20	2½	50
SNSL37234PF	SL37234PF	⅜ x 2¾	⅝-18	1¼	50
SNSL37400PF	SL37400PF	⅜ x 4	⅝-18	2½	50
SNSL37600PF	SL37600PF	⅜ x 6	⅝-18	4½	50
Round Head					
SNSL25200R	SL25200R	¼ x 2	⅜-24	⅞	100
SNSL37212R	SL37212R	⅜ x 2½	⅝-18	1	50



SIMPSON STRONG-TIE®
Sleeve Anchor with Rod Coupler

SLEEVE-ALL®

Sleeve-Alls are pre-assembled expanding sleeve anchors for use in all types of solid base materials.

- Material: Carbon steel
- Finish: Zinc plated



Item #	Size	Accepts Rod Dia.	Qty per Box	Qty per Ctn
	3/8" X 1 7/8"	3/8"	50	200
	1/2" X 2 1/4"	1/2"	25	100
	5/8" X 2 1/4"	5/8"	20	80

SIMPSON STRONG-TIE®
Internally Threaded Expansion Shell Anchor

DROP-IN

- Drop-in anchors are internally-threaded, deformation-controlled expansion anchors with a pre-assembled expander plug, suitable for flush mount applications in solid base materials
- The anchor is set by driving the expansion plug towards the bottom of the anchor using the setting tool



MATERIAL: Carbon and stainless steel
FINISH: Carbon steel: Zinc plated

Code Approvals: Drop-In: City of L.A. RR24682; Factory Mutual 3017082; Underwriters Laboratories File Ex3605. Meets requirements of Federal Specifications A-A-55614, Type I

Item #	Rod Size	Drill Bit Dia.	Bolt Thread	Body Length	Qty per Box
Carbon Steel					
SNDIA25	1/4"	3/8"	20	1"	100
SNDIA37	3/8"	1/2"	16	1 1/2"	50
SNDIA50	1/2"	5/8"	13	2"	50
SNDIA62	5/8"	7/8"	11	2 1/2"	25
SNDIA75	3/4"	1"	10	3 1/8"	20
303 Stainless Steel					
SNDIA37SS	3/8"	1/2"	16	1 1/2"	50
SNDIA50SS	1/2"	5/8"	13	2"	50

SIMPSON STRONG-TIE®
Internally Threaded Expansion Shell Anchor

Lipped DROP-IN Anchor

- Drop-in anchors are internally-threaded, deformation-controlled expansion anchors with a pre-assembled expander plug, suitable for flush mount applications in solid base materials
- The anchor is set by driving the expansion plug towards the bottom of the anchor using the setting tool
- The Lipped Drop-In (DIAL) features a lip at the top of the anchor body that keeps the top of the anchor flush with the concrete. This eliminates the need for precisely drilled hole depths and allows for easier flush installation, consistent embedment and uniform rod lengths



MATERIAL: Carbon steel

FINISH: Carbon steel: Zinc plated

Code Approvals: Drop-In: City of L.A. RR24682; Factory Mutual 3017082; Underwriters Laboratories File Ex3605. Meets requirements of Federal Specifications A-A-55614, Type I

Item #	Rod Size	Drill Bit Dia.	Bolt Thread	Body Length	Qty per Box
SNDIAL37	3/8"	1/2"	16	1 1/16"	50
SNDIAL50	1/2"	5/8"	13	2"	50

SIMPSON STRONG-TIE®
Internally Threaded Expansion Shell Anchor

Short DROP-IN Anchor

- Ask about using a stop drill bit
- Drop-in anchors are internally-threaded, deformation controlled expansion anchors with a pre-assembled expander plug, suitable for flush mount applications in solid base materials
- The anchor is set by driving the expansion plug towards the bottom of the anchor using the setting tool
- The 3/8" Short Drop-In Anchor (DIA37S) is for use in solid and hollow concrete. The short length permits shallow embedment, thus avoiding drilling into rebar or prestressing strands. The wide surface flange allows the DIA37S to be installed in deep or bottomless holes



MATERIAL: Carbon steel

FINISH: Carbon steel: Zinc plated

Code Approvals: Short Drop-In: Factory Mutual 3017082 & Underwriters Laboratories File Ex3605

- A dedicated setting tool is included with each box.

Item #	Rod Size	Drill Bit Dia.	Bolt Thread	Body Length	Qty per Box
SNDIA37S	3/8"	1/2"	16	3/4"	100
SNDIA50S	1/2"	5/8"	13	50	



SIMPSON STRONG-TIE®

Internally Threaded Expansion Shell Anchor

Coil Thread DROP-IN Anchor



- Drop-in anchors are internally-threaded, deformation-controlled expansion anchors with a pre-assembled expander plug, suitable for flush mount applications in solid base materials. The anchor is set by driving the expansion plug towards the bottom of the anchor using the setting tool

MATERIAL: Carbon steel

FINISH: Carbon steel: Zinc plated

Code Approvals: Drop-In: City of L.A. RR24682; Factory Mutual 3017082; Underwriters Laboratories File Ex3605. Meets requirements of Federal Specifications A-A-55614, Type I

Item #	Rod Size	Accepts Rod Dia.	Drill Bit Dia.	Bolt Thread	Body Length	Qty per Box	Qty per Ctn
SNDIA50C	1/2"	1/2"	5/8"	6"	2	50	200
SNDIA75C	3/4"	3/4"	1"	5"	3 1/8"	20	80

SIMPSON STRONG-TIE®

Injection Epoxy

ETI



ETI injection epoxies are specially designed formulations for the injection of cracks in concrete. ETI epoxies are two-component, 1:1 ratio, high solids formulations. They are available in 22 ounce side-by-side cartridges and are dispensed through a static mixing nozzle using a manual,

battery or pneumatic dispensing tool. ETI is available in two viscosities: ETI-LV (low viscosity) and ETI-GV (gel viscosity) to handle a wide range of crack widths. Properly installed, they provide a repair that is both waterproof and high strength (structural).

ETI-LV Low Viscosity Injection Epoxy:

- Low viscosity epoxy (1790 cps) for repair of fine to medium width cracks 1/4" - 1/4" in width
- Low surface tension allows the material to effectively penetrate narrow cracks
- Suitable for structural repairs

ETI-GV Gel Viscosity Injection Epoxy

- Gel viscosity epoxy for repair of medium cracks 3/32" - 1/4" in width
- Decreases in viscosity under pressure for increased flowability
- Suitable for structural repairs

APPLICATION: Epoxy-Tie® injection epoxies are suitable for repairing non-moving cracks in concrete walls, floors, slabs, columns and beams. They can be used to inject cracks in damp or wet conditions with excellent results. Apply to concrete 40°F or above. For best results, warm material to 60°F or above prior to application

- SHELF LIFE: 2 years in unopened cartridge

Item #	Capacity (oz.)	Cartridge Type	Ctn Qty.	Dispensing Tool(s)	Mixing Nozzle
SNETILV22	22	Side-by Side	10	EDT22B, EDT22AP, EDT22CKT	EMN022 (Included)
SNETIGV22	22	Side-by Side	10	EDT22B, EDT22AP, EDT22CKT	EMN022 (Included)

SIMPSON STRONG-TIE®

Drop-In Setting Tool



For use with carbon and stainless steel Drop-In anchors.

Item #	For Use With	Box Qty
SNDIAST25	DIA25, DIAL25	10
SNDIAST37	DIA37, DIAL37	10
SNDIAST50	DIA50, DIA50C, DIAL50	10
SNDIAST62	DIA62	5
SNDIAST75	DIA75, DIA75C	5



SIMPSON STRONG-TIE®
**Cast-in Place,
Internally Threaded
Inserts**



BLUE BANGER HANGER®

- Blue Banger Hanger® internally-threaded inserts are cast into the underside of the concrete deck after being fastened to the top of wood forms or metal deck. Once the concrete has cured, the anchor provides an attachment point for threaded rod used to hang electrical, mechanical and plumbing utilities
- The Blue Banger Hanger insert is the only pre-pour insert to offer the patented multi-thread design which allows one size insert to handle multiple diameters of threaded rod
- MATERIAL: Carbon steel
- FINISH: Yellow-zinc dichromate
- Code Approvals: Factory Mutual 3024378 (except roof deck insert); Underwriters Laboratories File EX3605 (except roof deck insert)

Item #	For Rod Dia. (in.)	Deck Hole Diameter (in.)	Box Qty.
--------	-----------------------	-----------------------------	----------

Metal Deck Insert

SNBBMD2550	1/4, 3/8, 1/2	13/16-7/8	100
SNMMBD3762	3/8, 1/2, 5/8	1 1/8-1 3/16	50
SNBBMD6275	5/8, 3/4	1 3/16-1 1/4	50

Roof Deck Insert

SNBBRD2550	1/4, 3/8, 1/2	7/8	50
------------	---------------	-----	----

Wood Form Insert

SNBBWF2550	1/4, 3/8, 1/2		200
SNBBWF3762	3/8, 1/2, 5/8	N/A	150
SNBBWF6275	5/8, 3/4	N/A	150

SIMPSON STRONG-TIE®
**Heli-Tie™ Fastener
Installation tool**



Heli-Tie™ Fastener Installation
Tool - Model HELITOOOL37A
Required for correct installation of Heli-Tie wall ties. Speeds up installation and automatically countersinks the tie into the facade material. The updated one-piece design with no moving parts drastically reduces the cost of the tool, improves longevity and prevents the Heli-Tie fasteners from jamming. Installation tools sold separately.

Item #
SNHELITOOOL37A

SIMPSON STRONG-TIE®
Helical Wall Tie



HELI-TIE™

The Heli-Tie™ is a stainless steel helical tie used to anchor building façades to structural members or to stabilize multiple wythe brick walls. The helical design allows the tie to be driven quickly and easily into a predrilled pilot hole (or embedded into mortar joints in new construction) to provide a mechanical connection between a masonry façade and its backup material or between multiple wythes of brick. As it is driven, the fins of the tie undercut the masonry to provide an expansion-free anchorage that will withstand tension and compression loads. The Heli-Tie is installed using a proprietary setting tool that is used with an SDS-Plus shank rotohammer to drive and countersink the tie. Heli-Tie performs in concrete and masonry as well as wood and steel studs.

- Installs quickly and easily - With the rotohammer in drill and hammer mode the tie installs faster than competitive products.
- Provides an inconspicuous repair that preserves the appearance of the building. After installation the tie is countersunk up to 1/2" below the surface, allowing the tie location to be patched.
- Corrosion resistant stainless steel.
- Larger core diameter provides higher torsional capacity resulting in less deflection due to "uncoiling" under load.
- Fractionally sized anchor - no metric drill bits required.
- Patented manufacturing process results in a more uniform helix along the entire tie allowing easier driving and better interlock with the substrate.
- "Simpson Heli-Tie" printed on every tie for easy identification and inspection.
- Material: 304 stainless steel (316 available by special order, contact Simpson for details)
- Test Criteria: CSA A370

Installation:

- Drill pilot hole through the façade material and to the specified embedment depth + 1" in the backup material using appropriate drill bit(s). Drill should be in rotation only mode when drilling into soft masonry or into hollow backing material.
- Position the Heli-Tie in the installation tool and insert the tie into the pilot hole.
- With the SDS-Plus rotohammer in rotation and hammer mode, drive the tie until the installation tool shoulders up to the exterior surface of the masonry and the drive pin is fully extended. The installation tool will countersink the tie below the surface. Patch the hole in the facade using a color-appropriate material.

Item #	Size	Qty per Box
--------	------	-------------

SNHELI37600	3/8" x 6"	100
SNHELI37700	3/8" x 7"	100
SNHELI37800	3/8" x 8"	100
SNHELI37900	3/8" x 9"	100
SNHELI371000	3/8" x 10"	150
SNHELI371100	3/8" x 11"	150
SNHELI371200	3/8" x 12"	150



ITW REDHEAD
A7 Acrylic Adhesives
Fast Dispensing/Fast Curing
Epcon



- All weather formula
- No drip, no sag, easy clean up
- Fast curing time, 35 minutes at 60°F
- NSF 61 approved
- Works in damp holes and underwater applications

Item #	Desc.	Box Qty.
RAA7-5	5 Fluid Ounce Cartridge	12
RAA7-8	8 Fluid Ounce Cartridge	12
RAA7-10	10 Fluid Ounce Cartridge	6
RAA7-28	28 Fluid Ounce Cartridge	4
RAA-24	Mixing Nozzle for A7-8 Cartridge	
RAA101	Hand Dispenser for A7-8 Cartridge	
RAA102	Hand Dispenser for A7-28	
RAA500-KIT	Dispensing Kit Package	
RAA501	Reusable Caulking Gun Adaptor	

ITW REDHEAD
C6 Epoxy Adhesives
Fast Curing
Epcon



The hardener and resin are completely mixed as they are dispensed from the dual cartridge through a static mixing nozzle. The pre-mixed adhesive is injected directly into the anchor hole. C6 can be used with threaded rod or rebar.

Advantages

- 1 hour cure time
- Works in damp holes and underwater applications
- Minimum shrinkage-can be used in oversized holes and diamond cored holes
- High heat deflection temperature: 140°F (ASTM D648)
- One formula for both solid and hollow base materials
- NSF standard 61 certified for drinking water systems
- Extensively tested-earthquake, underwater, creep, freeze-thaw, radiation, fire, fatigue, electrical isolation, ozone and many more test programs have been conducted on C6
- Extensive use-C6 has been used on projects all over the world for over 13 years

Features

Anchorage to solid concrete

Threaded rod (carbon or stainless steel) or rebar supplied by contractor; rod does not need to be chisel pointed

C6 adhesives completely fills area between rod and hole creating a stress-free, high load anchorage

Pre-drilled hole in concrete

Item #	Description	Box/Bag Qty
RAC6-18	C6 Adhesive, 18 Fl. Oz. Cartridge	1
RAE24	Mixing Nozzle (1/2 in. Outside Diameter)	4
RAE50	Mixing Nozzle (11/16 in. Outside Diameter)	5
RAE101	Hand Dispenser for C6-18 Cartridge	1
RAE200	Pneumatic Dispenser for C6-18 Cartridge	1
RAE300	Dosage Control Pneumatic Dispenser for C6-18 Cartridge	1



ITW REDHEAD
G5 Epoxy Adhesives
Completely Mixed
Epcon

The epoxy resin hardener are completely mixed as they are dispensed from the dual cartridge through a static mixing nozzle, directly into the anchor hole. G5 can be used with threaded rod or rebar.

Advantages

- Nozzles last longer-saves money
- Gives more time to install anchors
- Easier to install anchors in hot weather
- Easier installation of larger diameter anchors and deeper embedments
- Odorless

Features:

Anchorage to solid concrete

Rebar or threaded rod (carbon or stainless steel) supplied by contractor

G5 adhesives completely fills area between rod and hole creating a stress-free, high load anchorage

Pre-drilled hole in concrete

Description: G5 adhesive, 22 fluid oz. cartridge, Box/Bag Qty: 1, Carton Qty: 12

- Meets ASTM C881-90, Type II, Grade 3, Classes A, B, and C with the exception of bond strength
- Compressive strength, ASTM D695: 9170 psi minimum
- Shelf life: 2 years minimum
- Water solubility: None



Item #	Description	Box/Bag Qty
RAG5-22	G5 Adhesive, 22 Fl. Oz. Cartridge	6
RAE55	Mixing Nozzle for G5-22 Cartridge (3/8-5/8 in. Outside Diameter) 14 in. long	24
RAE102	Hand Dispenser for G5-22 Cartridges-Dispenses both 18 oz. and 22 oz. Cartridges	1
RAE202	Pneumatic Tool for G5-22 Cartridges	1
RARH7020	Cordless Dispensing tool for the G5-22 Cartridge	1

**Need submittal information?
Call Edge today.**

**We can provide manufacturer's
detailed specifications to meet your
project needs.**



ITW REDHEAD

Seismic Wedge Anchors

Trubolt® +

Trubolt® + Wedge anchors consist of a high-strength threaded stud body, expansion clip, nut and washer. Anchor bodies are made of plated carbon steel. The expansion clip consists of a split cylindrical ring with undercutting grooves.

- The exposed end of the anchor is stamped to identify anchor length. Stampings should be preserved during installation for any subsequent embedment verification
- Use carbide tipped hammer drill bits made in accordance with ANSI B212.15-1994 to install anchors
- ICC Evaluation Service, Inc. # ESR-2427
- Category 1 performance rating
- 2006 IBC and 2009 IBC compliant
- Meets ACI 318 ductility requirements
- Tested in accordance with ACI 355.2 and ICC-ES AC193
- For use in seismic zones A, B, C, D, E, & F
- 3/8", 1/2", 5/8" & 3/4" diameter anchors
- listed in ESR-2427
- City of Los Angeles - #RR25867
- 2009 IBC Compliant



Item #	Thread Length (in.)	Anchor Dia. (in.) & Drill Bit Size (Threads) per Inch	Overall Length (in.)	Max Thickness of Material to be Fastened in. (mm)	Qty/Wt per Box (lbs.)
RACWS-3830	1 $\frac{5}{8}$	$\frac{3}{8}$ -16	3 (76.2)	$\frac{5}{8}$ (15.9)	50/5.3
RACWS-3836	2 $\frac{3}{8}$	$\frac{3}{8}$ -16	3 $\frac{3}{4}$ (95.3)	1 $\frac{3}{8}$ (34.9)	50/5.9
RACWS-3850	3 $\frac{5}{8}$	$\frac{3}{8}$ -16	5 (127)	2 $\frac{5}{8}$ (66.7)	50/7.3
RACWS-1236	2 $\frac{1}{8}$	$\frac{1}{2}$ -13	3 $\frac{3}{4}$ (95.3)	$\frac{3}{4}$ (19.1)	25/5.7
RACWS-1244	2 $\frac{7}{8}$	$\frac{1}{2}$ -13	4 $\frac{1}{2}$ (114.3)	1 $\frac{1}{2}$ (38.1)	25/7
RACWS-1254	3 $\frac{7}{8}$	$\frac{1}{2}$ -13	5 $\frac{1}{2}$ (139.7)	2 $\frac{1}{2}$ (63.5)	25/8
RACWS-1270	5 $\frac{3}{8}$	$\frac{1}{2}$ -13	7 (177.8)	4 (101.6)	25/9.2
RACWS-5850	3 $\frac{3}{16}$	$\frac{5}{8}$ -11	5 (127)	1 $\frac{1}{8}$ (28.6)	10/4.7
RACWS-5860	4 $\frac{3}{16}$	$\frac{5}{8}$ -11	6 (152.4)	2 $\frac{1}{8}$ (54)	10/5.4
RACWS-5870	5 $\frac{3}{16}$	$\frac{5}{8}$ -11	7 (177.8)	3 $\frac{1}{8}$ (79.4)	10/6.2
RACWS-5884	5 $\frac{3}{4}$	$\frac{5}{8}$ -11	8 $\frac{1}{2}$ (215.9)	4 $\frac{5}{8}$ (117.5)	10/8
RACWS-3454	3 $\frac{5}{8}$	$\frac{3}{4}$ -10	5 $\frac{1}{2}$ (139.7)	1 $\frac{1}{2}$ (38.1)	50/7.6
RACWS-3462	4 $\frac{3}{8}$	$\frac{3}{4}$ -10	6 $\frac{1}{4}$ (158.8)	2 $\frac{1}{4}$ (57.2)	10/8.5
RACWS-3470	5 $\frac{1}{8}$	$\frac{3}{4}$ -10	7 (177.8)	3 (76.2)	10/9
RACWS-3484	5 $\frac{3}{4}$	$\frac{3}{4}$ -10	8 $\frac{1}{2}$ (215.9)	4 $\frac{1}{2}$ (114.3)	10/10.5
RACWS-34100	5 $\frac{3}{4}$	$\frac{3}{4}$ -10	10 (254)	6 (152.4)	10/11.9



ITW REDHEAD
Wedge Anchors

Carbon Steel With Zinc Plating
Trubolt®



- Expanding Wedge Anchor
- Inquire about detailed specifications

Item #	Thread Length in. (mm)	Anchor Dia. & Drill Bit Size (Threads) per (in.)	Overall Length in. (mm)	Max. Thickness of Material to be Fastened in. (mm)	Qty/Wt per Box (lbs.)	UoM
RAWS-1416	¾ (19.1)	¼ - 20	1¾ (44.5)	⅝ (9.5)	100/3.1	Ea
RAWS-1422	1¼ (31.8)	¼ - 20	2¼ (57.2)	⅞ (22.2)	100/3.6	Ea
RAWS-1432	2¼ (57.2)	¼ - 20	3¼ (82.6)	1⅞ (47.6)	100/4.7	Ea
RAWS-3822	1⅞ (28.6)	⅜ - 16	2¼ (57.2)	⅜ (9.5)	50/4.1	Ea
RAWS-3826	1⅞ (41.3)	⅜ - 16	2¾ (69.9)	⅞ (22.2)	50/4.7	Ea
RAWS-3830	1⅞ (47.6)	⅜ - 16	3 (76.2)	1⅞ (28.6)	50/5.0	Ea
RAWS-3836	2⅝ (66.7)	⅜ - 16	3¾ (95.3)	1⅞ (47.6)	50/5.9	Ea
RAWS-3850	2¾ (69.9)	⅜ - 16	5 (127.0)	3⅞ (79.4)	50/7.4	Ea
RAWS-3870	2¼ (57.2)	⅜ - 16	7 (177.8)	5⅞ (130.2)	50/10.4	Ea
RAWS-1226	1¼ (31.8)	½ - 13	2¾ (69.9)	⅞ (3.2)	25/4.6	Ea
RAWS-1236	2¼ (57.2)	½ - 13	3¾ (95.3)	1 (25.4)	25/5.7	Ea
RAWS_1242	2¾ (69.9)	½ - 13	4¼ (108.0)	1½ (38.1)	25/6.2	Ea
RAWS-1244	3 (76.2)	½ - 13	4½ (114.3)	1¾ (44.5)	25/6.5	Ea
RAWS-1254	3 (76.2)	½ - 13	5½ (139.7)	2¾ (69.9)	25/7.7	Ea
RAWS-1270	4½ (114.3)	½ - 13	7 (177.8)	4¼ (108.0)	25/9.3	Ea
RAWS-5834	1¾ (44.5)	⅝ - 11	3½ (88.9)	⅞ (3.2)	10/3.6	Ea
RAWS-5842	2-½ (63.5)	⅝ - 11	4¼ (108.0)	⅞ (22.2)	10/4.1	Ea
RAWS-5850	3¼ (82.6)	⅝ - 11	5 (127.0)	1⅞ (41.3)	10/4.7	Ea
RAWS-5860	3½ (88.9)	⅝ - 11	6 (152.4)	2⅝ (66.7)	10/5.4	Ea
RAWS-5870	4½ (114.3)	⅝ - 11	7 (177.8)	3⅝ (92.1)	10/6.2	Ea
RAWS-5884	3½ (88.9)	⅝ - 11	8½ (215.9)	5⅞ (130.2)	10/8.0	Ea
RAWS-58100	1¾ (44.5)	⅝ - 11	10 (254.0)	6⅝ (168.3)	10/9.4	Ea
RAWS-3442	1¾ (44.5)	¾ - 10	4¼ (108.0)	¼ (31.8)	10/6.8	Ea
RAWS-3446	2¼ (57.2)	¾ - 10	4¾ (120.7)	¾ (19.1)	10/7.4	Ea
RAWS-3454	3 (76.2)	¾ - 10	5½ (139.7)	1½ (38.1)	10/8.1	Ea
RAWS-3462	3¾ (95.3)	¾ - 10	6¼ (158.8)	2¼ (57.2)	10/9.1	Ea
RAWS-3470	4½ (114.3)	¾ - 10	7 (177.8)	3 (76.2)	10/9.7	Ea
RAWS-3484	3½ (88.9)	¾ - 10	8½ (215.9)	4½ (114.3)	10/12.3	Ea
RAWS-34100	1¾ (44.5)	¾ - 10	10 (254.0)	6 (152.4)	10/14.0	Ea
RAWS-34120	1¾ (44.5)	¾ - 10	12 (304.8)	8 (203.2)	10/16.6	Ea
RAWS-7860	2½ (63.5)	⅞ - 9	6 (152.4)	1⅞ (34.9)	5/6.3	Ea
RAWS-7880	2½ (63.5)	⅞ - 9	8 (203.2)	3⅞ (85.7)	5/8.1	Ea
RAWS-78100	2½ (63.5)	⅞ - 9	10 (254.0)	5⅞ (136.5)	5/9.8	Ea
RAWS-10060	2½ (63.5)	1/8/2002	6 (152.4)	½ (12.7)	5/8.3	Ea
RAWS-10090	2½ (63.5)	1/8/2002	9 (228.6)	3½ (88.9)	5/11.6	Ea
RAWS-100120	2½ (63.5)	1/8/2002	12 (304.8)	6½ (165.1)	5/15.0	Ea



ITW REDHEAD
Wedge Anchors

Type 304 Stainless Steel
Trubolt®



Typical applications-Cladding, stadium seating, etc.

Serves many applications well. It withstands rusting in architectural and food processing environments and resists organic chemicals, dye stuffs and many inorganic chemicals.

Item #	Thread Length in. (mm)	Anchor Dia. & Drill Bit Size (Threads) Per (in.)	Overall Length in. (mm)	Max. Thickness of Material to be Fastened in. (mm)	Qty/Wt per Box (lbs.)
RAWW-1416	¾ (19.1)	¼ - 20	1¾ (44.5)	⅜ (9.5)	100/3.2
RAWW-1422	1¼ (31.8)	¼ - 20	2¼ (57.2)	⅞ (22.2)	100/3.7
RAWW-1432	2¼ (57.2)	¼ - 20	3¼ (82.6)	1⅞ (47.6)	100/4.8
RAWW-3822	1⅞ (28.6)	⅜ - 16	2¼ (57.2)	⅜ (9.5)	50/4.1
RAWW-3826	1⅞ (41.3)	⅜ - 16	2¾ (69.9)	⅞ (22.2)	50/4.8
RAWW-3830	1⅞ (47.6)	⅜ - 16	3 (76.2)	1⅞ (28.6)	50/5.1
RAWW-3836	2⅝ (66.7)	⅜ - 16	3¾ (95.3)	1⅞ (47.6)	50/6.0
RAWW-3850	2¾ (69.9)	⅜ - 16	5 (127.0)	3⅞ (79.4)	50/7.5
RAWW-1226	1¼ (31.8)	½ - 13	2¾ (69.9)	⅞ (3.2)	25/4.7
RAWW-1236	2¼ (57.2)	½ - 13	3¾ (95.3)	1 (25.4)	25/5.8
RAWW-1242	2¾ (69.9)	½ - 13	4¼ (108.0)	1½ (38.1)	25/6.3
RAWW-1254	3 (76.2)	½ - 13	5½ (139.7)	2¾ (69.9)	25/7.7
RAWW-1270	3½ (88.9)	½ - 13	7 (177.8)	4¼ (108.0)	25/9.4
RAWW-5834	1¾ (44.5)	⅝ - 11	3½ (88.9)	⅞ (3.2)	10/3.6
RAWW-5850	3¼ (82.6)	⅝ - 11	5 (127.0)	1⅞ (41.3)	10/4.8
RAWW-5860	3½ (88.9)	⅝ - 11	6 (152.4)	2⅞ (66.7)	10/5.5
RAWW-5870	3½ (88.9)	⅝ - 11	7 (117.8)	3⅞ (92.1)	10/6.2
RAWW-3446	2¼ (57.2)	¾ - 10	4¾ (120.7)	¾ (19.1)	10/6.7
RAWW-3454	3 (76.2)	¾ - 10	5½ (139.7)	1½ (38.1)	10/7.5
RAWW-3470	4 (101.6)	¾ - 10	7 (117.8)	3 (76.2)	10/9.2
RAWW-34100	1¾ (44.5)	¾ - 10	10 (254.0)	6 (152.4)	10/13.5
RAWW-10090	2½ (63.5)	1/8/2002	9 (228.6)	3½ (88.9)	5/11.4

Need Stainless Steel?

Call Edge today!



ITW REDHEAD

Wedge Anchors

Type 316 Stainless Steel

Trubolt®



Typical applications-Pumps, diffusers, gates, weir plates, etc.
Environment-Industrial (moderate to heavy atmospheric pollution)
Level of corrosion-Medium to high
Typical applications-Tunnels, dams, tiles, lighting fixtures, etc.
Environment-Marine (heavy atmospheric pollution)
Level of corrosion-High

Contains more nickel and chromium than Type 304, and 2%-3% molybdenum, which gives it better corrosion resistance. It is especially more effective in chloride environments that tend to cause pitting.

Item #	Thread Length in. (mm)	Anchor Dia. & Drill Bit Size (Threads) Per (in.)	Overall Length in. (mm)	Max. Thickness of Material to be Fastened in. (mm)	Qty/Wt. per Box (lbs.)
RASWW-1422	1¼ (31.8)	¼ - 20	2¼ (57.2)	⅞ (22.2)	100/3.7
RASWW-1432	2¼ (57.2)	¼ - 20	3¼ (82.6)	1⅞ (28.6)	100/4.8
RASWW-3826	1⅝ (41.3)	⅜ - 16	2¾ (69.9)	⅞ (22.2)	50/4.8
RASWW-3830	1⅞ (47.6)	⅜ - 16	3 (76.2)	1⅞ (28.6)	50/5.2
RASWW-3836	2⅝ (66.7)	⅜ - 16	3¾ (95.5)	1⅞ (47.6)	50/6.0
RASWW-1226	1¼ (31.8)	½ - 13	2¾ (69.9)	⅞ (3.2)	25/4.7
RASWW-1236	2¼ (57.2)	½ - 13	3¾ (95.3)	1 (25.4)	25/5.8
RASWW-1242	2¾ (69.9)	½ - 13	4¼ (108.0)	1½ (38.1)	25/6.5
RASWW-1254	3 (76.2)	½ - 13	5½ (139.7)	2¾ (69.9)	25/7.8
RASWW-5850	3¼ (82.6)	⅝ - 11	5 (127.0)	1⅞ (41.3)	10/4.8
	3 (76.2)	¾ - 10	5½ (139.7)	1½ (38.1)	10/8.1

ITW REDHEAD

Drop-In Anchors

Lipped

RM Series

- For solid concrete, lightweight fill deck
- Lipped anchor body keeps anchor flush



Item #	Bolt Size-Threads per (in.)	Drill Bit Size in. (mm)	Thread Depth in. (mm)	Embedment Min. Hole Depth in. (mm)	Qty/Wt. per Box (lbs.)
RARM-14	¼ - 20	⅜ (9.5)	1 (25.4)	100/2.6	
RARM-38	⅜ - 16	½ (12.7)	1⅞ (41.3)	50/3.4	
RARM-12	½ - 13	⅝ (15.9)	¾ (19.1)	2 (50.8)	50/5.8
RASSRM-12	½ - 13	⅝ (15.9)	¾ (19.1)	2 (50.8)	50/5.8



ITW REDHEAD
Drop-In Anchors

**Shallow Embedment
RX Series**



- ASK ABOUT USING A STOP DRILL BIT
- Optimized for use in hollow-core, pre-cast plank and post-tension slabs
- Lip keeps anchor flush during installation
- Shallow drilling—fast installation
- Inquire about stop-bit to save time and keep drilling from going too deep

Item #	Bolt Size-Threads per (in.)	Drill Bit Size in.	Thread Depth in.	Embedment Min. Hole Depth in. (mm)	Qty/Wt. per Box (lbs.)
RARX-38	3/8 - 16	1/2	3/8	3/4	100/3.5
RARX-12	1/2 - 13	5/8	1/2	1	50/3.0

ITW REDHEAD
Drop-In Anchors

**Shell-Type
Multi-Set II®**



- Specified for anchorage into concrete
- Drop-in, shell-type anchors feature an internally threaded, all-steel shell with expansion cone insert and flush embedment lip
- Easy removability-use any head style or material bolt rod
- Below surface setting for easy patch work

Item #	Bolt Size-Threads per (in.)	Drill Bit Size in. (mm)	Thread Depth in. (mm)	Embedment Min. Hole Depth in. (mm)	Setting Tool Part Number	Qty/Wt. Tool per Box (lbs.)
RARL-14	1/4 - 20	3/8 (9.5)	1 (25.4)	RT-114	100/2.6	
RARL-38	3/8 - 16	1/2 (12.7)	1 5/8 (41.3)	RT-138	50/3.4	
RARL-12	1/2 - 13	5/8 (15.9)	3/4 (19.1)	2 (50.8)	RT-112	50/5.8
RARL-58	5/8 - 11	7/8 (22.2)	1 (25.4)	2 1/2 (63.5)	RT-158	25/7.8
RARL-34	3/4 - 10	1 (25.4)	1 1/4 (31.8)	3 3/16 (81.0)	RT-134	25/11.9

18-8 S.S.

RASRM-14	1/4 - 20	3/8 (9.5)	1 (25.4)	RT-114	100/2.6	
RASRM-38	3/8 - 16	1/2 (12.7)	1 5/8 (41.3)	RT-138	50/3.4	
RASRM-12	1/2 - 13	5/8 (15.9)	3/4 (19.1)	2 (50.8)	RT-112	50/5.8
RASRM-58	5/8 - 11	7/8 (22.2)	1 (25.4)	2 1/2 (63.5)	RT-158	25/7.8
RASRM-34	3/4 - 10	1 (25.4)	1 1/4 (31.8)	3 3/16 (81.0)	RT-134	25/11.9

ITW REDHEAD
Drop-In Anchors Setting Tools



Item #	Desc.
RART-114	1/4" Tool
RART-138	3/8" Tool
RART-112	1/2" Tool
RART-158	5/8" Tool
RART-134	3/4" Tool
RARTX-138	3/8" Tool RX Series



ITW REDHEAD
Sleeve Anchors

**Carbon Steel
Dynabolt®**

Carbon steel with zinc plating
Typical applications - Shelf ledgers, electrical boxes, conduit
Environment - Interior (non-corrosive)
Level of corrosion - Low



Item #	Head Style	Anchor Dia. (in.) & Drill Bit Size (Threads) per Inch	Effective Anchor Length in. (mm)	Bolt Dia. (in.) / Threads per Inch	Min. Embedment in. (mm)	Max. Thickness of Material to be Fastened in. (mm)	Qty/Wt per Box (lbs.)
RAHN-1405	Hex Nut	1/4 - 20	5/8 (15.9)	3/16 /24	1/2 (12.7)	1/8 (3.2)	100/ 1.6
RAHN-5860	Hex Nut	5/8 - 11	6 (152.4)	1/2 /13	2 (50.8)	4 (101.6)	10/ 4.9
RAHX-1222	Hex Coupling (Rod Hanger)	1/2 - 13	2 1/4 (57.2)	1/2 /13 Hanger	1 7/8 (47.6)		25/ 6.5
RAHX-3822	Hex Coupling (Rod Hanger)	3/8 - 16	1 7/8 (47.6)	3/8 /16 Hanger	1 1/2 (38.1)		50/ 6.0

ITW REDHEAD
Sleeve Anchors

**Stainless Steel
Dynabolt®**

Type 304 stainless steel
Typical applications - Cladding and brick ties
Environment - Slight to moderate degree of pollution
Level of corrosion - Medium

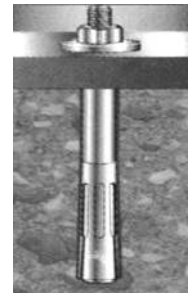

Item #	Anchor Dia. (in.) & Drill Bit Size (Threads) per Inch	Effective Anchor Length in. (mm)	Bolt Dia. (in.) / Threads per Inch	Min. Embedment in. (mm)	Max. Thickness of Material to be Fastened in. (mm)	Qty/Wt per Box (lbs.)	Qty/Wt per Master Carton (lbs.)	Head Style
RASFS-1430	1/4 - 20	3 1/8 (79.4)	3/16 /24	1 1/8 (28.6)	3 (76.2)	100/ 3.8	1000/ 38	Flat Head
RASFS-3826	3/8 - 16	2 7/8 (73.0)	5/16 /18	1 1/2 (38.1)	1 3/8 (34.9)	50/ 3.8	500/ 40	Flat Head
RASFS-3840	3/8 - 16	4 (101.6)	5/16 /18	1 1/2 (38.1)	2 1/2 (63.5)	50/ 5.3	400/ 44	Flat Head
RASHN-1230	1/2 - 13	3 (76.2)	3/8 /16	1 7/8 (47.6)	1 1/8 (28.6)	25/ 4.0	200/ 33	Hex Nut
RASRS-1420	1/4 - 20	2 (50.8)	3/16 /24	1 1/8 (28.6)	7/8 (22.2)	100/ 2.7	1000/ 28	Round Head



ITW REDHEAD
"Original Masonry" Anchors
Fast & Easy
Tapcon®



- The "Original masonry" anchor that cut its own threads into concrete, brick, or block. Maximum performance is achieved because the tapcon anchor, the condrive installation tool, and the carbide-tipped tapcon drill bits are designed to work as a system. It is essential to use the condrive tool and the correct drill bit to assure consistent anchor performance.
- Works in all masonry base materials
- Removable and reusable
- Slotted hex and phillips flat head styles
- Excellent corrosion protection-Climaseal™ coated
- Hi-Lo threads with notches cut into masonry materials for greater stability and pullout values
- Lengths of tapcon anchors range from 1-1/4" to 4" in 3/16" and up to 6" and 1/4" diameters.
- Anchor embedment-with a minimum of 1-1/4" to a maximum of 1-3/4" anchor embedment recommended.
- Hole diameter-proper hole diameter is very important to insure consistent performance and maximum pullout strength. 3/16" anchors require 5/32" diameter bits, and 1/4" anchors require 3/16" diameter bits
- All boxes of ITW Tapcon come packaged with matching carbide-tipped bit; Tapcon is packaged 100 pieces per box

Item #	Tapcon Length in. (mm)	Fixture Thickness (in.)	Bit Length in. (mm)	UoM
--------	------------------------	-------------------------	---------------------	-----

3/16 in. Hex Head

RAHW3-114	1 1/4 (31.8)	0 - 1/4	3 1/2 (88.9)	Ea
RAHW3-134	1 3/4 (44.5)	1/4 - 3/4	3 1/2 (88.9)	Ea
RAHW3-214	2 1/4 (57.2)	3/4 - 1 1/4	4 1/2 (114.3)	Ea
RAHW3-234	2 3/4 (69.9)	1 1/4 - 1 3/4	4 1/2 (114.3)	Ea
RAHW3-314	3 1/4 (82.6)	1 3/4 - 2 1/4	5 1/2 (139.7)	Ea

[1/4] in. Hex Head

RAHW4-114	1 1/4 (31.8)	0 - 1/4	3 1/2 (88.9)	Ea
RAHW4-134	1 3/4 (44.5)	1/4 - 3/4	3 1/2 (88.9)	Ea
RAHW4-214	2 1/4 (57.2)	3/4 - 1 1/4	4 1/2 (114.3)	Ea
RAHW4-234	2 3/4 (69.9)	1 1/4 - 1 3/4	4 1/2 (114.3)	Ea
RAHW4-314	3 1/4 (82.6)	1 3/4 - 2 1/4	5 1/2 (139.7)	Ea

3/16 in. Flat Head

RAPF3-114	1 1/4 (31.8)	0 - 1/4	3 1/2 (88.9)	Ea
RAPF3-134	1 3/4 (44.5)	1/4 - 3/4	3 1/2 (88.9)	Ea
RAPF3-214	2 1/4 (57.2)	3/4 - 1 1/4	4 1/2 (114.3)	Ea
RAPF3-234	2 3/4 (69.9)	1 1/4 - 1 3/4	4 1/2 (114.3)	Ea
RAPF3-314	3 1/4 (82.6)	1 3/4 - 2 1/4	5 1/2 (139.7)	Ea

1/4 in. Flat Head

RAPF4-114	1 1/4 (31.8)	0 - 1/4	3 1/2 (88.9)	Ea
RAPF4-134	1 3/4 (44.5)			
RAPF4-214	2 1/4 (57.2)	3/4 - 1 1/4	4 1/2 (114.3)	Ea
RAPF4-234	2 3/4 (69.9)			
RAPF4-314	3 1/4 (82.6)	1 3/4 - 2 1/4	5 1/2 (139.7)	Ea

ITW REDHEAD

Blow-Out Bulb

- Qty/Bag: 1

Item #
RABB-10



POWERS FASTENERS
Power-Stud+™ SD2



Wedge Type Expansion Anchor

- Base Material: Normal-Weight Concrete, Structural Dand-Lightweight Concrete, Concrete over Metal Deck, Grout-Filled Masonry
- Anchor Material: Zinc-plated Carbon Steel Body with Stainless Steel Expansion Clip
- The {Power-Stud+SD2 anchor is a fully threaded, torque-controlled, wedge expansion anchor which is designed for consistent performance in cracked and uncracked concrete
- CRACKED CONCRETE APPROVALS
- Code Listed: ICC-ES ESR-2502

Item #	Size (in.)	Thread Length (in.)	Std. Box
RL7413SD2	3/8X3	1 1/8	50
RL7414SD2	3/8X3 1/2	2 1/4	50
RL7415SD2	3/8X3 3/4	2 1/2	50
RL7416SD2	3/8X5	3 3/4	50
RL7422SD2	1/2X3 3/4	2 1/8	50
RL7423SD2	1/2X4 1/2	2 7/8	50
RL7424SD2	1/2X5 1/2	2 7/8	50
RL7426SD2	1/2X7	5 3/8	25
RL7427SD2	1/2X8 1/2	6 7/8	25
RL7435SD2	5/8X4 3/4	2 7/8	25
RL7433SD2	5/8X5	3 3/8	25
RL7434SD2	5/8X6	4 1/8	25
RL7436SD2	5/8X7	5 1/8	25
RL7438SD2	5/8X8 1/2	6 5/8	25
RL7442SD2	3/4X5 1/2	3 3/4	20
RL7444SD2	3/4X6 1/4	4	20
RL7446SD2	3/4X7	4 3/4	20
RL7448SD2	3/4X8 1/2	6 1/4	10



POWERS FASTENERS

Power-Stud+™ SD1
Wedge Type Expansion
Anchor



- Base Material: Normal-Weight Concrete, Structural Dand-Light-weight Concrete, Concrete over Metal Deck, Grout-Filled Masonry
- Anchor Material: Zinc-plated Carbon Steel Body and Expansion Clip, with Nut and Washer
- The Power-Stud+SD1 anchor is a fully threaded, torque-controlled, wedge expansion anchor which is designed for consistent performance in cracked and uncracked concrete
- CRACKED CONCRETE APPROVALS
- Code Approvals Listed: ICC-ES ESR-2818, ICC-ES ESR-2966

Item #	Size (in.)	Thread Length (in.)	Std. Box
RL7400SD1	1/4X1 3/4	3/4	100
RL7402SD1	1/4X2 1/4	1 1/4	100
RL7404SD1	1/4X3 1/4	2 1/4	100
RL7410SD1	3/8X2 1/4	7/8	50
RL7412SD1	3/8X2 3/4	1 3/8	50
RL7413SD1	3/8X3	1 5/8	50
RL7414SD1	3/8X3 1/2	2 1/8	50
RL7415SD1	3/8X3 3/4	2 3/8	50
RL7416SD1	3/8X5	3 3/8	50
RL7417SD1	3/8X7	5 3/8	50
RL7420SD1	1/2X2 3/4	1	50
RL7422SD1	1/2X3 3/4	2	50
RL7424SD1	1/2X5 1/2	2 3/4	50
RL7426SD1	1/2X7	5 1/4	25
RL7427SD1	1/2X8 1/2	6 3/4	25
RL7428SD1	1/2X10	8 1/4	25
RL7430SD1	5/8X3 1/2	1 1/2	25
RL7432SD1	5/8x4 1/2	2 1/2	25
RL7433SD1	5/8X5	3	25
RL7434SD1	5/8X6	4	25
RL7436SD1	5/8X7	5	25
RL7438SD1	5/8X8 1/2	6 1/2	25
RL7439SD1	5/8X10	8	25
RL7440SD1	3/4X4 1/4	1 3/4	20
RL7441SD1	3/4X4 3/4	2 1/4	20
RL7442SD1	3/4X5 1/2	3	20
RL7444SD1	3/4X6 1/4	3 3/4	20
RL7446SD1	3/4X7	4 1/2	20
RL7448SD1	3/4X8 1/2	6	10
RL7449SD1	3/4X10	7 1/2	10
RL7451SD1	3/4X12	9 1/2	10
RL7450SD1	7/8X6	2 3/4	10
RL7452SD1	7/8X8	4 3/4	10
RL7454SD1	7/8X10	6 3/4	10
RL7461SD1	1X6	2 3/8	10
RL7463SD1	1X9	5 3/8	10
RL7463SD1	1X12	8 3/8	5
RL7465SD1	1 1/4X9	4 3/4	5
RL7473SD1	1 1/4X9	4 3/4	5
RL7475SD1	1 1/4X12	7 3/4	5

POWERS FASTENERS
Wedge-Bolt® + Screw
Anchor



Carbon Steel
Wedge-Bolt®

- INSTALL WITH POWERS WEDGE BIT
- Base Material: Normal-Weight Concrete, Structural Sand-Light-weight Concrete, Concrete Over Metal Deck, Grouted CMU
- Anchor is made of Zinc Plated Carbon Steel with a Hex Head
- The Wedge-Bolt®+ anchor is a one piece, heavy-duty screw anchor with a finished hex head
- Simple to install, easy to identify and fully removable
- Designed for consistent and reliable performance in CRACKED AND UNCRACKED CONCRETE
- Code Approvals: ICCES ESR-2526 (Concrete), ICCES ESR-1678 (CMU)

Item #	Dia. Size & Length (in.)	Min. Embed. (in.)	Std. Box
RL7204SD	1/4 x 1 1/4	1	100
RL7206SD	1/4 x 1 3/4	1	100
RL7208SD	1/4 x 2 1/4	1 3/4	100
RL7210SD	1/4 x 3	1 3/4	100
RL7220SD	3/8 x 1 3/4	1 1/2	50
RL7222SD	3/8 x 2 1/2	2 1/8	50
RL7224SD	3/8 x 3	2 1/8	50
RL7226SD	3/8 x 4	2 1/8	50
RL7228SD	3/8 x 5	2 1/8	50
RL7230SD	3/8 x 6	2 1/8	50
RL7240SD	1/2 x 2	1 3/4	50
RL7242SD	1/2 x 2 1/2	2	50
RL7244SD	1/2 x 3	2 1/2	50
RL7246SD	1/2 x 4	2 1/2	50
RL7248SD	1/2 x 5	2 1/2	25
RL7250SD	1/2 x 6	2 1/2	25
RL7268SD	1/2 x 6 1/2	2 1/2	25
RL7252SD	1/2 x 8	2 1/2	25
RL7260SD	5/8 x 3	2 1/2	25
RL7262SD	5/8 x 4	3 1/4	25
RL7264SD	5/8 x 5	3 1/4	25
RL7266SD	5/8 x 6	3 1/4	25
RL7270SD	5/8 x 8	3 1/4	25
RL7280SD	3/4 x 3	2 1/2	20
RL7282SD	3/4 x 4	3	20
RL7284SD	3/4 x 5	4 1/4	20
RL7286SD	3/4 x 6	4 1/4	20
RL7288SD	3/4 x 8	4 1/4	10
RL7290SD	3/4 x 10	4 1/4	10



POWERS FASTENERS

Wedge-Bit™

Wedge-Bit™



- For proper performance, the Wedge-Bolt® anchor must be installed with a Wedge-Bit™
- The Wedge-Bit™ has a special matched tolerance range designed to provide optimum performance for the anchor
- Std. Pouch: 1

Item #	Drill Size (in.)	Usable Length (in.)	Overall Length (in.)
--------	------------------	---------------------	----------------------

SDS-PLUS WEDGE BIT™

RL1312	¼	2	4
RL1314	¼	4	6
RL1316	⅜	4	6
RL1318	⅜	6	8
RL1320	½	4	6
RL1322	½	8	10
RL1324	⅝	6	8
RL1326	⅝	10	12
RL1328	¾	6	8
RL1330	¾	10	12

SPLINE WEDGE-BIT™

RL1344	⅝	8	13
RL1348	¾	8	13

SDS-MAX WEDGE-BIT™

RL1356	⅝	8	13
RL1358	¾	8	13

POWERS FASTENERS

Snake+™



Internally Threaded Self-Tapping Anchor

- Base Material: Normal-Weight Concrete, Structural Sand-Light-weight Concrete, Concrete Over Metal Deck
- Anchor Material: Zinc Plated Carbon Steel
- Code Approvals: ICCES ESR-2272 (3/8 diameter)

Item #	Size (in.)	Min. Hole Depth (in.)	Internal Thread Depth (in.)	Std. Box
RL6401SD	⅜	1⅝	1¼	50
RL6403SD	½	2½	2⅝	50

POWERS FASTENERS

Snake Setting Tool

- Snake & Snake+ setting tool

Item #	Size (in.)	Std. Box
RL6407SD	⅜	1
RL6404SD	½	1



POWERS FASTENERS

Concrete Vertgo®+

Rod Hanger System

- Rod hanger for Concrete applications
- Finish: Yellow Dichromate
- Full ctns. packed with Wedge-Bit
- Code Listed: ESR-2989



Item #	Rod Size (in.)	Screw Shank Size and Length (in.)	Box Qty.
RL7180SD	¼	⅜X2⅝	100
RL7181SD	⅜	⅜X2⅝	100
RL7182SD	½	⅜X2⅝	50

Driver Socket for Vertgo™ + Anchors

RL7198SD	N/A	5
----------	-----	---

POWERS FASTENERS

AC100+Gold®

Acrylic Adhesive Anchoring System

The AC100+Gold is a two-component vinyl ester adhesive anchoring system. The system includes injection adhesive in plastic cartridges, mixing nozzles, dispensing tools and hole cleaning equipment. The AC100+Gold is designed for bonding threaded and reinforcing bar hardware into holes in concrete and masonry base materials.



- Mixing nozzle included with each cartridge
- Code Approvals: ICC-ES ESR-2582

Item #	Cartridge Size (oz.)	Cartridge Type	Std. Box
RL8478SD	10	Quik-Shot	12
RL8480SD	8	Dual Cartridge	12
RL8486SD	12	Dual Cartridge	12
RL8490SD	28	Dual Cartridge	8

Cartridge System Mixing Nozzles

RL08293	5,8,10, 12	AC100+Gold	2
RL08294	28 (includes 8" extension)	AC100+Gold	2
RL08281	8" Mixing Nozzle Extension	AC100+Gold	2



POWERS FASTENERS

Manual Injection Tools for AC100+ Gold



RL08484



RL08495

Item #	Desc.	Box Qty.	Carton Qty.
RL08484	AC100+Gold 8 oz. standard all metal manual tool	1	20
RL08495	AC100+Gold 28 oz. high performance manual tool	1	20

POWERS FASTENERS

Blue Perma-Seal Tapper+



Masonry Screw Anchor Tapper Screws

- The Tapper Anchoring System is a family of screw anchors, specially designed drill bits and installation tools designed to meet the needs of most light to medium duty applications in concrete, block and brick
- The Tapper concrete screw anchor is produced in either hex washer head or Phillips head styles from Perma-Seal® coated or zinc plated carbon steel
- The anchor is fast and easy to install providing a neat, finished appearance in a variety of vase materials including poured concrete, brick and concrete block for applications in new construction, remodeling and maintenance
- During installation, the specially designed nail point guides the anchor into a pre drilled hole; as the anchor is driven into the hole, the threads cut into the walls of the hole to provide a tight friction fit

Item #	Size (in.)	Drill Bit Range (in.)	Usable Length (in.)
--------	------------	-----------------------	---------------------

Hex Washer Head

RL2700SD	3/16x1 1/4
RL2702SD	3/16x1 3/4
RL2704SD	3/16x2 1/4
RL2706SD	3/16x2 3/4
RL2708SD	3/16x3 1/4
RL2710SD	3/16x3 3/4
RL2712SD	3/16x4
RL2720SD	1/4x1 1/4
RL2722SD	1/4x1 3/4
RL2724SD	1/4x2 1/4
RL2726SD	1/4x2 3/4

Item #	Size (in.)	Drill Bit Range (in.)	Usable Length (in.)
--------	------------	-----------------------	---------------------

RL2728SD	1/4x3 1/4
RL2730SD	1/4x3 3/4
RL2732SD	1/4x4
RL2734SD	1/4x5
RL2736SD	1/4x6

Phillips Flat Head

RL2740SD	3/16x1 1/4
RL2742SD	3/16x1 3/4
RL2744SD	3/16x2 1/4
RL2746SD	3/16x2 3/4
RL2748SD	3/16x3 1/4
RL2750SD	3/16x3 3/4
RL2752SD	3/16x4
RL2760SD	1/4x1 1/4
RL2762SD	1/4x1 3/4
RL2766SD	1/4x2 3/4
RL2768SD	1/4x3 1/4
RL2770SD	1/4x3 3/4
RL2764SD	1/4x2 1/4
RL2772SD	1/4x4
RL2774SD	1/4x5
RL2776SD	1/4x6

Straight Shank Drill Bits for Tapper+

RL2781	5/32 x 3 1/2	0.168-0.175	2
RL2782	5/32 x 4 1/2	0.168-0.175	3
RL2783	5/32 x 5 1/2	0.168-0.175	4
RL2785	3/16 x 3 1/2	0.202-0.204	2
RL2786	3/16 x 4 1/2	0.202-0.204	3
RL2787	3/16 x 5 1/2	0.202-0.204	4
RL2788	3/16 x 6 1/2	0.202-0.204	5
RL2789		0.202-0.204	6

Hex Shank SDS-Plus Bits for Tapper+

RL2793	5/32 x 5	0.168-0.175	3
RL2794	5/32 x 7	0.168-0.175	5
RL2796	3/16 x 5	0.202-0.204	3
RL2797	3/16 x 7	0.202-0.204	5



POWERS FASTENERS

Hole Cleaning Tools & Accessories



Item #	Desc.	Length (in.)	Std. Package
RL08284	Wire brush for 7/16" ANSI hole (5/8" rod or #3 rebar)	6 3/4	1
RL08285	Wire brush for 9/16" ANSI hole (1/2" rod or #4 rebar)	6 3/4	1
RL08286	Wire brush for 1 1/16" ANSI hole (5/8" rod or #5 rebar)	7 7/8	1
RL08287	Wire brush for 7/8" ANSI hole (3/4" rod or #6 rebar)	7 7/8	1
RL08288	Wire brush for 1" ANSI hole (7/8" rod or #7 rebar)	11 7/8	1
RL08289	Wire brush for 1 1/8" ANSI hole (1" rod or #8 rebar)	11 7/8	1
RL08290	Wire brush for 1 3/8" ANSI hole (1 1/4" rod or #9 rebar)	11 7/8	1
RL08291	Wire brush for 1 1/2" ANSI hole (#10 rebar)	11 7/8	1
RL08283	SDS-plus adapter for steel brushes		1
RL08296	Standard drill adapter for steel brushes (e.g. Jacobs Chuck)		1
RL08282	Steel brush extension, 12"		1
RL08280	Hand pump/dust blower (25 fl. oz. cylinder volume)		1

POWERS FASTENERS

PE1000+®

Epoxy Adhesive Anchoring System



The PE1000+® is a two-component, high strength epoxy adhesive anchoring system. The system includes injection adhesive in plastic cartridges, mixing nozzles, dispensing tools and hole cleaning equipment. The PE1000+® is designed for bonding threaded rod and reinforcing bar hardware into drilled holes in solid concrete base materials.

- Mixing nozzle included with each cartridge
- Code Approvals: ICC-ES ESR-2583

Item #	Cartridge Size (oz.)	Cartridge Type	Std. Box
RL0500SD	13	Dual Cartridge	12
RL0502SD	20	Dual Cartridge	12

Cartridge System Mixing Nozzles

RL08294	13,20	PE1000+	2
RL08281	8" Mixing Nozzle Extension	PE1000+	2

POWERS FASTENERS

PE1000+ Dispensing Tool



RL08298

- RL08298 shown

Item #	Desc.	Standard Box
RL08298	20 oz. PE1000+ heavy-duty manual dispensing tool	1
RL08497SD	13 oz. + 20 oz. PE1000+ pneumatic dispensing tool	1

POWERS FASTENERS

Zamac Hammer-Screw Anchors



Mushroom Head

Zamac Hammer-Screw®

- The Zamac Hammer-Screw® is a unique, one-step drive anchor featuring a Phillips type head and a screw thread for use in concrete, block, brick or stone.
- With a body formed from corrosion resistant Zamac alloy and a carbon drive screw, this anchor has been developed by Powers as an improvement over standard nailin anchors.
- Traditionally, Zamac Nailin® anchors have been used for light duty, non-engineered applications and have not been recommended for use overhead. In order to overcome these problems, the new Zamac Hammer-Screw® has been designed to provide a removable anchor with 40% higher tension load capacities when installed in concrete.
- The Zamac Hammer-Screw® can be used overhead provided it is part of an engineered system designed by an engineer who will take the proper design considerations and safety factors into account.
- Mushroom head with No. 2 Phillips type screw
- Base material: Concrete, block, brick, stone
- Anchor material: Zamac alloy with carbon or stainless steel drive screw
- Drill Dia.: 1/4"

Item #	Size (in.)	Std. Box	UoM
RL2839	1/4 x 3/4	100	Ea
RL2840	1/4 x 1	100	Ea
RL2842	1/4 x 1 1/4	100	Ea
RL2844	1/4 x 1 1/2	100	Ea
RL2846	1/4 x 2	100	Ea
RL2848	1/4 x 2 1/4	100	
RL2850	1/4 x 3	100	Ea
RL2939	1/4 x 3/4	1000	
RL2940	1/4 x 1	1000	Ea
RL2942	1/4 x 1 1/4	1000	Ea
RL2944	1/4 x 1 1/2	1000	Ea
RL2946	1/4 x 2	1000	Ea
RL2948	1/4 x 2 1/4	1000	



POWERS FASTENERS
Zamac Nailin®

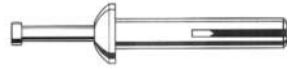

Drive Pin Type Anchor

- Base material: Concrete, block, brick, stone
- Anchor material: Zamac alloy with carbon or stainless steel drive pin
- The Zamac Nailin® is a temper-proof nail drive anchor which has a body formed from Zamac alloy
- Nails are available in carbon or stainless steel
- The anchor can be used in concrete, block, brick or stone, this anchor is not recommended for applications overhead

Item #	Size (in.)	Drill Dia. (in.)	Std. Box
--------	------------	------------------	----------

Mushroom Head - Carbon Steel Nail

RL2802	3/16 x 7/8	3/16	100
RL2803	3/16 x 7/8	3/16	1000
RL2806	1/4 x 3/4	1/4	100
RL2808	1/4 x 1	1/4	100
RL2814	1/4 x 1 1/4	1/4	100
RL2820	1/4 x 1 1/2	1/4	100
RL2826	1/4 x 2	1/4	100
RL2804	1/4 x 3	1/4	100

POWERS FASTENERS
Nylon Nailin®



Plastic Drive Pin Type Anchor

- Base material: Concrete, block, brick
- Anchor material: Engineered nylon with carbon or stainless steel drive pin
- The Nylon Nailin® is a pin drive anchor with a body formed from engineered nylon and nails available in carbon and stainless steel
- The anchor can be used in concrete, block, or brick, this anchor is not recommended for applications overhead

Item #	Size (in.)	Drill Diam. (in.)	Std. Box
--------	------------	-------------------	----------

Round Head Nylon Nailin®-Carbon Steel Nail

RL2542	1/4 x 1 1/2	1/4	100
RL2562	1/4 x 2	1/4	100

Mushroom Head Nylon Nailin®-Carbon Steel Nail

RL2433	3/16 x 1	3/16	100
RL2513	1/4 x 3/4	1/4	100
RL2523	1/4 x 1	1/4	100
RL2543	1/4 x 1 1/2	1/4	100
RL2563	1/4 x 2	1/4	100
RL2573	1/4 x 3	1/4	100
RL2583	1/4 x 4	1/4	100

POWERS FASTENERS
Spike® Anchor
Spike®



- Base material: Concrete, block, brick, stone
- The Spike® anchor is a patented, one-piece, tamper-proof vibration resistant anchor for use in concrete, block, brick or stone
- The Spike® anchor is formed with an "s" shaped configuration at the working end of the anchor to create an expansion mechanism
- Since the anchor is pre-expanded, there is no secondary tightening operation required which greatly reduces the overall cost of an anchor installation

Item #	Head Size (in.)	Drill Dia. (in.)	Min. Embed. (in.)	Tie-Wire Hole Size	Std. Box
--------	-----------------	------------------	-------------------	--------------------	----------

Pipe Spike®

RL3755	1/4	3/16	1 1/4		100
RL3758	3/8	1/4	1 3/4		100

Tie-Wire Spike®

RL3756	3/16	1 1/4	3/16	100	
RL3759	1/4	1 1/4	3/32	100	

Forming Spike®

RL3795	3/16 x 1 1/2	3/16	1 1/4		100
RL3794	1/4 x 2 3/4	1/4	1 1/4		100

POWERS FASTENERS
Pipe Spike® Setting Tool



- While the Spike® anchor can easily be installed using a hammer, a specially designed series of drivers and manual tools provide a fast, easy to use method for installing Spike® anchors into concrete and masonry materials
- The tools allow Spike® anchors to be installed in confined areas and prevent damage to the fixture from stray hammer blows
- TIP O.D.: 5/16"

Item #

RL3760

POWERS FASTENERS
Steel Dropin



Stainless Steel

- Type 304 Stainless Steel Dropin

Item #	Size (in.)	Drill Dia. (in.)	Min. Depth (in.)	Thread Depth (in.)	Std. Box
RL6206	3/8	1/2	1 9/16	5/8	50
RL6208	1/2	5/8	2	1 3/16	50



POWERS FASTENERS

Spike® Anchor



Mushroom Head Spike®

- Base material: Concrete, block, brick, stone
- Anchor material: Grade 8.2 carbon steel
- The Spike® anchor is a patented, one-piece, tamper-proof vibration resistant anchor for use in concrete, block, brick or stone
- The Spike® anchor is formed with an "s" shaped configuration at the working end of the anchor to create an expansion mechanism
- Since the anchor is pre-expanded, there is no secondary tightening operation required which greatly reduces the overall cost of an anchor installation

Item #	Size (in.)	Drill Dia. (in.)	Min. Embed. (in.)	Std. Box
RL5522	¼ x 1	¼	⅞	100
RL5523	¼ x 1¼	¼	1	100
RL5524	¼ x 1½	¼	1¼	100
RL5526	¼ x 2	¼	1¼	100
RL5528	¼ x 2½	¼	1¼	100
RL5530	¼ x 3	¼	1¼	100
RL5531	¼ x 3½	¼	1¼	100
RL5532	¼ x 4	¼	1¼	100

POWERS FASTENERS

Split Drive Type Anchors



Carbon Steel Drive®

- Base material: Concrete, stone
- The Drive® is a one piece tamper-proof, pre-expanded anchor available in carbon steel for use in concrete and stone
- Tie-Wire Drive® anchors are used for suspended ceiling applications
- The flat head (counter-sunk) style is particularly suited for wood-to-concrete anchoring
- The round head style is for all other applications requiring fast, permanent installations

Item #	Size (in.)	Drill Dia. (in.)	Min. Depth (in.)	Std. Box
RL3631	⅝ x 2½	⅝	1⅞	25
RL3691	⅝ x 3½	⅝	1⅞	25
RL3272	¼ x 2	¼	1⅞	100
RL3302	¼ x 2½	¼	1⅞	100
RL3332	¼ x 3	¼	1⅞	100
RL3362	¼ x 3½	¼	1⅞	100
RL3392	¼ x 4	¼	1⅞	100

Round Head Drive®

Flat Head Drive®

Tie-Wire Drive® (⅜ in. Tie-Wire Hole)

POWERS FASTENERS

Toggle Bolt



- The Toggle Bolt is a spring wing type hollow wall anchor designed for use in block, wallboard and other hollow base materials; the Toggle Bolt is a two-part assembly consisting of a machine screw and a spring wing toggle
- The Toggle wing is a permanently pre-assembled unit consisting of four parts: two precision-stamped steel wings attached to a threaded trunnion nut and a pre-stressed high-tensile coil spring
- As the anchor is tightened, the wing configuration is designed to sit flat against the underside of the wall, providing even distribution of loading to prevent pull-through

Item #	Size (in.)	Drill Dia. (in.)
RL4131	⅜x3	½
RL4141	⅜x4	½
RL4231	¼x3	⅝
RL4241	¼x4	⅝
RL4441	⅝x4	⅞

POWERS FASTENERS

Strap-Toggle™



Hollow Wall Anchor

- The Strap-Toggle™ is a pre-assembled anchor consisting of a carbon steel wing and a locking cap/ratchet leg assembly molded from engineered plastic
- When compared to traditional toggles, this unique anchor can be installed through a smaller hole and does not require a fixture or screw to set in the base material

Item #	Size (in.)	Drill Dia. (in.)	Std. Box
RL4054	¼ x 4	½	50
RL4056	⅝ x 4	¾	25

POWERS FASTENERS

Wallboard Anchors



Engineered Nylon or Zamac Alloy Zip-It®

- Base Material: Wallboard
- The Zip-It® anchor is a one piece self drilling anchor designed for use in hollow gypsum wallboard for light duty loads
- It is available in both engineered nylon and zamac alloy for use with either No. 6 or No. 8 screws in 3/8" to 1" wallboard
- The Zip-It® Jr. is formed from engineered nylon for use with No. 6 screws in 3/8" to 5/8" wallboard
- Std. Box: 100

Item #	Wall Thickness (in.)	Desc.
RL2348	⅝ to 1	Std. box, No. 8 x 1" screws



POWERS FASTENERS

Anchor Fasteners Plastic Bantam Plug



Plastic anchor designed for use with lightweight fixtures using a sheet metal or wood screw. A flange formed at the top end of the anchor body allows it to be used in hollow base materials of concrete, block, brick and wallboard. It should not be used overhead. Priced per hundred and sold in full box quantities only.

Size: 10-12 x 1", Drill Dia: 1/4", Min. depth: 1"

- Use in concrete, block, brick, wallboard
- Use with sheet metal or wood screw
- Made of corrosion-resistant plastic
- Layout or hole spotting required
- Light duty
- Collar for hollow material
- Available in kits, includes 100 plugs and slotted/Phillips sheet metal screws, and one Rawl rotary carbide drill bit
- Screw length is equal to work thickness plus anchor length

Item #	Size (in.)	Drill Dia. (in.)	Min. Dpth. (in.)
RL7559	#6-8x3/4	3/16	3/4
RL7569	#8-10x7/8	3/16	7/8
RL7579	#10-12x1	1/4	1
RL7589	#14-16x1 1/2	5/16	1 1/2

Plug (Anchor)

Kits (Anchor & Screw)

POWERS FASTENERS

Wallboard Anchor Zip-It®



- The Zip-It® anchor is a one piece self drilling anchor designed for use in hollow gypsum wallboard for light duty loads, it is available in both engineered nylon and Zamac alloy for use with No. 8 screws in 3/8" to 1" wallboard
- During installation, the unique drill tip of the Zip-It® uses four offset blades to ensure fast and true cutting
- Two blades are cutting blades and the other two are guide blades that stabilize the anchor for speed and accuracy during installation
- The holding capacity of the anchor is achieved through a unique thread design
- Thin, knife-like threads have an oversized outer diameter that cuts deeply and cleanly into the wallboard to spread the load over a large bearing area while the tapered root of the threaded section compacts the wall material around the anchor to further increase the load capacity
- Once fully seated, the collar of the Zip-it® sets flush to the surface of the wallboard
- Standard box: 100

Item #	Desc.	Type
RL2345	Standard Box, No Screws	Nylon
RL2346Z	Standard Box, No Screws	Zinc
Zip-It® Kit		
RL2349	Standard Box No. 8 x 1" screws	Zinc



BUILDEX

Sammys® For Wood Vertical Application Sammys®



- No pre-drilling required
- Quick to install using the Sammy Nut Driver with a cordless drill/driver
- Saves time from traditional methods
- Reduces installation costs
- 1/4"-3/8" use #14 Black Nut Driver #8113910, 1/2" use #14 SW Red Nut Driver # 8114910
- Made in the USA

Item #	Model	Size (in.)	Rod Size (in.)	Ultimate Pull-out (lbs.)
RABX8002957	GST 100	1/4 X 1	1/4	210 (7/16 OSB) 670 (3/4 PLY)
RABX5003957	GST 200	1/4 X 2	1/4	1760 (FIR)
RABX8004957	GST 300	1/4 X 3	1/4	2060 (FIR)
RABX8007957	GST 10	1/4 X 1	3/8	210 (7/16 OSB) 670 (3/4 PLY)
RABX8008957	GST 20	1/4 X 2	3/8	1760 (FIR)
RABX8008925	GST 20-SS	1/4 X 2	3/8	1760 (FIR)
RABX8009925	GST 25-380	3/8 X 2 1/2	3/8	2113 (FIR)
RABX8010957	GST 30	1/4 X 3	3/8	2060 (FIR)
RABX8069925	GST 30-SS	1/4 X 3	3/8	2060 (FIR)
RABX8011925	GST 40	1/4 X 4	3/8	2180 (FIR)
RABX8013925	GST 2	1/4 X 2	1/2	1760 (FIR)
RABX8014925	GST 2.5-380	3/8 X 2 1/2	1/2	2113 (FIR)
RABX8015925	GST 3	1/4 X 3	1/2	2275 (FIR)

BUILDEX

Sammys® Side-winder™ For Wood Horizontal Applications Sammys®



- Installs horizontally into the side of wood structures easily and quickly
- Use #14 SW Red Nut Driver # 8114910
- No pre-drilling required

Item #	Model	Size (in.)	Rod Size (in.)	Ultimate Pull-out (lbs.)
RABX8019957	SWG 200	1/4x2	1/4	1725 (FIR)
RABX8020957	SWG 10	1/4x1	3/8	622 (FIR)
RABX8021957	SWG 20	1/4x2	3/8	1725 (FIR)
RABX8073925	SWG 20-SS	1/4x2	3/8	1725 (FIR)
RABX8022925	SWG 25-380	3/8x2 1/2	3/8	2249 (FIR)
RABX8023925	SWG 30	1/4x3	3/8	1884 (FIR)

SAMMYS®

BUILDEX

Sammys® Swivel Head™ For Wood

Swivel Application

Sammys®



- Eliminates distortion of threaded rod
- Accommodates up to 3-1/2" x 12 pitch roof
- Allows 17° deflection from vertical
- 3/8" use #14 Black Nut Driver #8113910, 1/2" use #14 SH Orange Nut Driver # 8273910
- Made in the USA

Item #	Model	Size (in.)	Rod Size (in.)	Ultimate Pullout (lbs.)
RABX8139957	SH-GST 20	¼ X 2	¾	1257 (FIR)
RABX8141957	SH-GST 30	¼ X 3	¾	1720 (FIR)
RABX8269957	SH-GST/CST 20	5/16 X 1¾	¾	1903 Dim. Lumber 1406 @ 45° Off Vertical Dim. Lumber
RABX8303957	SH-GST/CST 2.0	5/16 X 1¾	½	903 Dim. Lumber 1406 @ 45° Off Vertical Dim. Lumber

BUILDEX

Sammys® For Steel

Vertical Application

Sammys®



- Made with TekS® self-drilling fasteners - no pre-drilling required
- Installs into steel range from 20 gauge – 1/2" thicknesses
- Quick to install using the Sammys® Nut Driver with a cordless drill/driver
- A standard screwgun with a depth sensitive nosepiece should be used to install TekS; for optimal fastener performance, the screwgun should be a minimum of 6 amps and have an RPM range of 0-2500
- 1/4"-3/8" use #14 Black Nut Driver #8113910, 1/2" use #14 SW Red Nut Driver # 8114910
- Made in the USA

Item #	Model	Size	Rod Size (in.)	Ultimate Pullout (lbs.)
RABX8024957	DSTR 100*	¼-20 X 1 TEKS 3	¼	1510 (20GA.)
RABX8025957	DST 100	¼-14 X 1 TEKS 3	¼	446 (20GA.)
RABX8026957	DST 150	¼-14 X 1½ TEKS 3	¼	970 (16GA.)
RABX8027957	DST 200	¼-14 X 2 TEKS 3	¼	446 (20GA.)
RABX8030957	TEK 500	12-24 X 1½ TEKS 5	¼	3125 (¾")
RABX8038957	DSTR 1*	¼-20 X 1 TEKS 3	¾	1510 (20GA.)
RABX8037957	DSTR 1½*	12-24 X 1½ TEKS 5	¾	1510 (¾")
RABX8039957	DSTR 516*	5/16-18 X 1¼	¾	2200 (20GA.)
RABX8040957	DST 10	¼-14 X 1 TEKS 3	¾	446 (20GA.) 970 (16GA.)
RABX8077925	DST10-SS	¼-14 X 1 TEKS 3	¾	446 (20GA.) 970 (16GA.)
RABX8041957	DST 15	¼-14 X 1½ TEKS 3	¾	446 (20GA.) 970 (16GA.)
RABX8078925	DST 15-SS	¼-14 X 1½ TEKS 3	¾	446 (20GA.) 970 (16GA.)
RABX8042957	DST 20	¼-14 X 2 TEKS 3	¾	446 (20GA.) 970 (16GA.)
RABX8043957	DST 25	¼-14 X 2½ TEKS 3	¾	446 (20GA.) 970 (16GA.)
RABX8044957	DST 30	¼-14 X 3 TEKS 3	¾	446 (20GA.) 970 (16GA.)
RABX8045957	DST 516	5/16-18 X 1¼ TEKS 3	¾	1500 (¾")
RABX8046957	TEK 50	12-24 X 1½ TEKS 5	¾	3125 (¾")
RABX8031925	DST 2.0	¼-14 X 2 TEKS 3	½	446 (20GA.) 970 (16GA.)
RABX8033925	DSTR 1.0*	¼-20 X 1 TEKS 3	½	1510 (20GA.)
RABX8034925	DSTR 5.16*	5/16-18 X 1¼ TEKS 3	½	2200 (20GA.)
RABX8035925	DST 5.16	5/16-18 X 1¼ TEKS 3	½	1500 (¾")
RABX8036925	TEK 5.0	12-24 X 1½ TEKS 5	½	3125 (¾")

* Includes Retaining Nut



SAMMYS®

BUILDEX

Sammys® Sidewinder™ For Steel



Horizontal Application Sammys®

- Made with TekS® self-drilling fasteners - no pre-drilling required
- Installs into steel range from 20 gauge – 1/2" thicknesses
- A standard screwgun with a depth sensitive nosepiece should be used to install TekS; for optimal fastener performance, the screwgun should be a minimum of 6 amps and have an RPM range of 0-2500
- Saves time from traditional methods
- Reduces installation costs
- Quick to install using the Sammys Nut Driver with a cordless drill/driver
- Use #14 SW Red Nut Driver # 8114910
- Made in the USA

Item #	Model	Size	Rod Size (in.)	Ultimate Pullout (lbs.)
RABX8047957	SWD 100	¼-14 X 1 TEKS 3	¼	1477 (16GA.)
RABX8049957	SWDR 100*	¼-14 X 1 TEKS 3	¼	1900 (20GA.)
RABX8050957	SWD 10	¼-14 X 1 TEKS 3	⅜	1477 (16GA.)
RABX8080925	SWD 10-SS	¼-14 X 1 TEKS 3	⅜	1477 (16GA.)
RABX8051957	SWD 15	¼-14 X 1½ TEKS 3	⅜	1477 (16GA.)
RABX8052957	SWD 20	¼-14 X 2 TEKS 3	⅜	1477 (16GA.)
RABX8053957	SWD 516	⅝-18 X 1¼ TEKS 3	⅜	2480 (20GA.)
RABX8055957	SWDR 1*	¼-20 X 1 TEKS 3	⅜	1900 (20GA.)
RABX8054957	SWDR 1½*	12-24 X 1½ TEKS 5	⅜	2375 (⅜")
RABX8056957	SWDR 516*	⅝-18 X 1¼ TEKS 3	⅜	2480 (20ga.)
RABX8057957	SWT 15	12-24 X 1½ TEKS 5	⅜	2375 (⅜")

* Includes Retaining Nut

BUILDEX

Sammys® Swivel Head™ For Steel

Swivel Applications Sammys®



- Eliminates distortion of threaded rod in sloped roof applications
- Accommodates 3-1/2 x 12 pitch
- Installs into angled z-purlin; allows threaded rod to hang plumb
- Allows 17° deflection from vertical
- 3/8" use #14 Black Nut Driver #8113910, 1/2" use #14 SH Orange Nut Driver # 8273910
- Made in the USA

Item #	Model	Size (in.)	Rod Size (in.)	Ultimate Pullout (lbs.)
RABX8137957	SH-DSTR 1*	¼-20 X 1 TEKS 3	⅜	3220 (⅜")
RABX8268957	SH-TEK 50	12-24 X 1¼ TEKS 5	⅜	2368 (½" Steel Vertical) 1306 (45° Off Vertical) 2281 (⅜" HSS) 1585 (⅜" HSS 45° Off Vertical)
RABX8270957	SH-TEK 5.0	12-24 X 1¼ TEKS 5	½	2368 (½" Steel Vertical) 1306 (45° Off Vertical) 2281 (⅜" HSS) 1585 (⅜" HSS 45° Off Vertical)

* DOES NOT Comply With ROHS Requirements / Includes Retaining Nut

SAMMYS®

BUILDEX
Sammys® X-Press®

Vertical Application
Sammys®



- The Sammys® X-Press™ expands to provide direct vertical attachment in light gauge steel deck or purlin, (22 ga. - 1/8")
- Installs in seconds with Sammys® X-Press It™ Tool, saving time & installation costs
- Use in applications where access to the back of the installed fastener is prohibited: metal roof deck, tubular steel, or vapor barrier fabric
- Less jobsite material needed
- No retaining nut required
- Provides design flexibility
- Made in the USA

Item #	Model	Rod Size (in.)	Application	Ultimate Pullout (lbs.)
RABX8181922	XP 200	1/4	Metal Deck	1146 (22GA.)
RABX8150922	XP 20	3/8	Metal Deck	1146 (22GA.)
RABX8153922	XP 35	3/8	Purlin	1783 (16GA.)
RABX8150922	XP 20	3/8	Metal Deck (Pre-Pour) Metal Deck (Post-Pour)	1146 (22GA.)

BUILDEX
Sammys® X-Press Sidewinder™

Horizontal Application
Sammys®



- The Sidewinder X-Press Sidewinder™ expands to provide horizontal attachment in: 16 ga - 3/16" steel - purlin, tubular steel
- Installs in seconds with Sammys® X-Press It® Tool, saving time & installation costs
- Use in applications where access to the back of the installed fastener is prohibited; metal roof deck, tubular steel, or vapor barrier fabric

Item #	Model	Rod Size (in.)	Application	Ultimate Pullout (lbs.)
RABX8293957	SWXP 35	3/8	Purlin	1798 (16 GA.)

BUILDEX
Sammys® X-Press Swivel™

Swivel Application
Sammys®



- The X-Press Swivel™ allows you to hang plumb in extreme roof pitches: 89° in z-purlin, 45° in metal deck for 12/12 pitch
- Installs in seconds with Sammys® X-Press It™ Tool, saving time & installation costs
- Use in applications where access to the back of the installed fastener is prohibited: metal roof deck, tubular steel, or vapor barrier fabric

Item #	Model	Rod Size (in.)	Application	Ultimate Pullout (lbs.)
RABX8294922	SXP 20	3/8	Metal Deck	1061 (22 GA. Vert) 829 (45° Off Vert)
RABX8295922	SXP 35	3/8	Purlin	1675 (16 GA. Vert) 1558 (89° Off Vert)
RABX8272957	SXP 2.0	1/2	Metal Deck	1061 (22 GA. Vert) 829 45° Off Vert)
RABX8271957	SXP 3.5	1/2	Purlin	1675 (16 GA. Vert) 1558 (89° Off Vert)



SAMMYS®

BUILDEX

Sammys® X-Press It™

Install Tool Sammys®



- The Sammy® X-Press™ expands to provide direct vertical attachment in: metal deck (22-16 gauge), z-purlin (18-16 gauge)
- Made in the USA

Item #	Model	Desc.
RABX8194910	UXPIT	Universal X-Press It Tool
RABX8152910	XPDB	25/64" Drill Bit

BUILDEX

Sammys® For Concrete

Vertical Application Sammys®



- Easy two step process (Drill hole & drive Sammys® concrete anchor)
- 1/4" pre-drilled pilot hole required
- Concrete Installation Tool available for a one tool installation process
- 1/4"-3/8" use #14 Black Nut Driver #8113910, 1/2" use #14 SW Red Nut Driver # 8114910
- Made in the USA

Item #	Model	Size (in.)	Rod Size (in.)	Ultimate Pull-out (lbs.)
RABX8058957	CST 200	5/16x1 3/4	1/4	2400
RABX8059957	CST 20	5/16x1 3/4"	3/8	2400
RABX8145925	CST 20-SS	5/16x1 3/4	3/8	2400
RABX8060925	CST 2	5/16x1 3/4	1/2	2400

BUILDEX

Sidewinder® For Concrete

Horizontal Application Sammys®



- Easy two step process (Drill hole & drive Sammys concrete anchor)
- 1/4" pre-drilled pilot hole required
- Concrete Installation Tool available for a one tool installation process
- Use #14 SW Red Nut Driver # 8114910
- Made in the USA

Item #	Model	Size (in.)	Rod Size (in.)	Ultimate Pullout (lbs.)
RABX8062957	SWC 200	5/16x1 3/4	1/4	2450
RABX8061957	SWC 20	5/16x1 3/4	3/8	2450

BUILDEX Concrete/Wood Instal- lation Kit

Sammys®

- Includes: (1 each) #14 Black Nut Driver, #14 SW Red Nut Driver, #250 Bit (1/4"), SDS Bit (1/4"), 7/32 Wood Bit, HEX 250 Bit Receiver (1/4") and SL 250 Sleeve



Item #	Desc.
RABX8122910	Concrete Installation Kit
RABX8121910	SDS B250 Bit Receiver (1/4")

BUILDEX

Speedy Pole Tool™

Sammys®



- Ideal for retrofit and hard-to-reach projects in wood and steel
- Hang it high from down low

Item #	Length (ft.)
RABX8123910	6
RABX8124910	12
RABX8125910	18
RABX8126910	24

BUILDEX

Speedy Pole Tool™

Socket Kit Sammys®

- Used with Sammys® Speedy Pole Tools™
- 8129910 includes: (1 of each) Adaptor Plug, Socket Driver for Sammys®, Socket Driver for Ceiling Wire Screws, Socket Driver for 1/4" Standard Nut Drivers, Stuf Plug for Viper or Ladd Powder Actuated Attachment



Item #	Desc.
RABX8127910	Sammys® Socket Driver
RABX8128910	Ceiling Wire Socket Driver for Wire and Chain
RABX8129910	Universal Pole Tool Socket Kit

BUILDEX

#14 Nut Driver

Sammys®

Item #	Color
RABX8113910	Black
RABX8114910	Red
RABX8273910	Orange



SAMMYS®

BUILDEX

Sammys® Swivel Head™ For Concrete

Swivel Application Sammys®



- Installs vertically and swivels up to 89° in wood & concrete structures
- Eliminates distortion of threaded rod
- 1/4" pre-drilled pilot hole required
- Concrete installation tool available for a one piece installation process
- Use #14 SH Orange Nut Driver # 8273910
- Made in the USA

Item #	Model	Size (in.)	Rod Size (in.)	Ultimate Pullout (lbs.)
RABX8269957	SH-GST/CST 20	5/16 X 1 1/4	3/8	2537 IN 3000 PSI Concrete 1459 @ 45° Off Vertical IN 3000 PSI Concrete 2852 IN 6000 PSI Concrete 1636 @ 45° Off Vertical IN 6000 PSI Concrete
RABX8303957	SH-GST/CST 2.0	5/16 X 1 1/4	1/2	2537 IN 3000 PSI Concrete 1459 @ 45° Off Vertical IN 3000 PSI Concrete 2852 IN 6000 PSI Concrete 1636 @ 45° Off Vertical IN 6000 PSI Concrete

BUILDEX

Toggle for Drywall or Concrete

Sammys®



Installation Instructions:

1. Pre-drill a 5/8" hole with a regular drill or hole saw
2. Insert SST screw into #14 Black Nut Driver # 8113910 with wing nut and washer on bolt, insert wing nut through surface, and begin installation
3. When bolt is secure and nut driver spins free, stop drill motor and remove
4. SST screw is now ready to receive 1/4", 3/8", or Metric all thread rod or bolt stock

Item #	Model	Size (in.)	Rod Size (in.)	Ultimate Pullout (lbs.)
RABX8063925	SST 300	1/4x3	1/4	450 (Lath & Plaster) 404 (2 Layers 5/8" Rock)
RABX8064925	SST 30	1/4x3	3/8	450 (Lath & Plaster) 404 (2 Layers 5/8" Rock)

So many options for hanging all-thread . . . so little time!!!

Call Edge for help with your specific application.



BUILDEX

Teks® Self-Drilling Fasteners

Light-Duty Steel-to-Steel Applications

Applications:

- Stitch roof deck and wall panel sidelaps
- HVAC, electrical trim accessories to steel framing
- Residential steel frame construction
- Brick ties to steel framing
- Track to stud and stud splicing
- Hat channel to stud

Head Styles:

- Hex Washer Head
- Oval Head
- Pan Head
- Hex Washer Head with Serrations



Item #	Desc.	Head Style	Drill Point	Max. Material Attachments	Drill and Tap Capacity	Box Qty.
RABX1208200	6-20x ³ / ₈ "	Pan	#2	.100	.036-.100	20,000
RABX1563200	6-20x ³ / ₈ "	HWH	#2		.036-.100	20,000
RABX1527200	6-20x ¹ / ₂ "	Pan	#2		.036-.100	20,000
RABX1210200	8-18x ¹ / ₂ "	Pan	#2	.205	.036-.100	10,000
RABX1213200	8-18x ³ / ₄ "	Pan	#2	.455	.036-.100	10,000
RABX1218200	8-18x1"	Pan	#2	.705	.036-.100	8,000
RABX1196200	8-18x ¹ / ₂ "	HWH	#2	.205	.036-.100	10,000
RABX1199200	8-18x ⁵ / ₈ "	HWH	#2	.330	.036-.100	10,000
RABX1200200	8-18x ³ / ₄ "	HWH	#2	.455	.036-.100	10,000
RABX1202200	8-18x1"	HWH	#2	.705	.036-.100	8,000
RABX1204200	8-18x1 ¹ / ₂ "	HWH	#2	1.205	.036-.100	4,000
RABX1107053	10-16x ³ / ₄ "	HWH	#1	.220	.018-.095	5,000
RABX1109053	12-14x ³ / ₄ "	HWH	#1	.205	.018-.095	4,000
RABX1399053	1/4-14x ⁷ / ₈ "	HWH	#1	.380	.018-.095	5,000

**Need special finish or
submittal information?**

Call Edge today!



BUILDEX

Teks® Self-Drilling Fasteners

Medium-Duty Steel-to-Steel Applications



Applications:

- Roof deck to steel framing
- Wall panel to girt
- Duct work to steel framing
- Accessories to steel framing
- Roof clip to steel framing
- Retrofit framing
- Commercial overhead steel doors, hinges and latches

Head Styles:

- Hex Washer Head
- Hex Washer Head with Serrations

Item #	Desc.	Head Style	Drill Point	Drill and Tap Capacity	Max. Material Attachments	Box Qty.
RABX1134000	12-14x3/4"	HWH	#3	.036-0210	.270	5,000
RABX1136000	12-14x1"	HWH	#3	.036-0210	.520	4,000
RABX1120000	12-14x1 1/4"	HWH	#3	.036-0210	.550	4,000
RABX1123000	12-14x1 1/2"	HWH	#3	.036-0210	.800	2,500
RABX1140000	12-14x2"	HWH	#3	.036-0210	1.450	2,000
RABX1553000	12-14x2 1/2"	HWH	#3	.036-0210	1.950	1,000
RABX1143000	12-14x3"	HWH	#3	.036-0210	2.450	1,000
RABX1146000	12-14x4"	HWH	#3	.036-0210	3.450	500
RABX1147000	1/4-14x3/4"	HWH	#3	.036-0210	.210	3,000
RABX1149000	1/4-14x1	HWH	#3	.036-0210	.400	2,500
RABX1150000	1/4-14x1 1/4"	HWH	#3	.036-0210	.650	2,000
RABX1152000	1/4-14x1 1/2"	HWH	#3	.036-0210	.900	2,000
RABX1155000	1/4-14x2"	HWH	#3	.036-0210	1.400	1,500
RABX1554000	1/4-14x2 1/2"	HWH	#3	.036-0210	1.900	1,000
RABX1157000	1/4-14x3"	HWH	#3	.036-0210	2.400	1,000
RABX1304000	1/4-14x4"	HWH	#3	.036-0210	3.400	500
RABX1586000	1/4-14x3/4"	*HWH	#3	.036-0210	.250	3,000
RABX1587000	1/4-14x1"	*HWH	#3	.036-0210	.500	2,500

*7/16 Across Flats HWH with serrations under head

Attaching dissimilar metals?

Ask about Tek Select



BUILDEX
Teks® Self-Drilling Fasteners
Heavy-Duty Steel-to-Steel Applications



Applications:

- Metal deck to structural steel or bar joist
- Clips to structural steel or bar joist
- Liner panels to structural steel or bar joist
- Accessories to structural steel or bar joist
- Longer length fasteners can be used in retrofit clip and sheet applications

Head Style:

- Hex Washer Head

Item #	Desc.	Head Style	Drill Point	Drill and Tap Capacity	Max. Material Attachments	Box Qty.
RABX1088000	12-24x7/8"	HWH	#4	.125-.250	.325	5,000
RABX1414000	12-24x1 1/4"	HWH	#4.5	.125-.375	.575	4,000
RABX1006000	12-24x1 1/4"	HWH	#5	.125-.500	.375	4,000
RABX1070000	12-24x1 1/2"	HWH	#5	.125-.500	.625	2,500
RABX1071000	12-24x1 1/2"	**HWH	#5	.125-.500	.625	2,000
RABX1072000	12-24x2"	HWH	#5	.125-.500	1.125	2,000
RABX1074000	1/4-28x3"	*HWH	#5	.125-.500	2.150	1,000
RABX1075000	1/4-28x4"	*HWH	#5	.125-.500	3.150	500
RABX1641000	1/4-28x5"	HWH	#5	.125-.500	4.150	250
RABX1431000	1/4-28x6"	HWH	#5	.125-.500	5.150	250
RABX1590000	1/4-28x8"	HWH	#5	.125-.500	7.150	150

* 5/16 Across Flats HWH, ** 3/8 Across Flats HWH

**What's your application: HVAC,
roofing, solar, metal buildings, . . . ?**

**Call Edge for help in selecting the best
fastener.**



BUILDEX

Teks® Self-Drilling Fastener With Bonded Washer

Metal Roof and Wall Applications



Application:

- Roof panels to purlins or bar joist
- Wall panels to girt
- Mansard panel to structural

Head Style:

- Hex Washer Head with Bonded Washer

Item #	Desc.	Head Style	Drill Point	Drill and Tap Capacity	Max. Material Attachments	Box Qty.
RABX1005000	10-16x3/4"	HWH	#3	.036-.175	.205	3,000
RABX1308000	10-16x1 1/2"	HWH	#3	.036-.175	.955	2,500
RABX1009000	12-14x3/4"	HWH	#3	.036-.210	.150	3,000
RABX1011000	12-14x1"	HWH	#3	.036-.210	.400	3,000
RABX1014000	12-14x1 1/4"	HWH	#2	.036-.210	.430	2,500
RABX1404000	12-14x1 1/2"	HWH	#2	.036-.210	.680	2,000
RABS1016000	12-14x2"	HWH	#3	.036-.210	1.330	1,500
RABX1333000	12-14x3"	HWH	#3	.036-.210	2.330	1,000
RABX1332000	12-14x4"	HWH	#3	.036-.210	3.330	500
RABX1416000	1/4-14x7/8"	HWH	#1	.018-.095	.260	3,000
RABX1160000	1/4-14x1"	HWH	#3	.036-.210	.280	2,500
RABX1019000	1/4-14x1 1/4"	HWH	#3	.036-.210	.530	2,000
RABX1020000	1/4-14x1 1/2"	HWH	#3	.036-.210	.780	1,500
RABX1021000	1/4-14x2"	HWH	#3	.036-.210	1.280	1,000
RABX1555000	1/4-14x2 1/2"	HWH	#3	.036-.210	1.780	1,000
RABX1022000	1/4-14x3"	HWH	#3	.036-.210	2.280	750
RABX1429000	1/4-14x4"	HWH	#3	.036-.210	3.280	500
RABX1010000	12-24x7/8"	HWH	#4	.125-.250	.205	3,000
RABX1415000	12-24x1 1/4"	HWH	#4.5	.125-.375	.455	2,500
RABX1000000	12-24x1 1/4"	HWH	#5	.125-.500	.255	2,500
RABX1001000	12-24x1 1/2"	HWH	#5	.125-.500	.505	2,000
RABX1002000	12-24x2"	HWH	#5	.125-.500	1.005	1,500
RABX1003000	1/4-28x3"	**HWH	#5	.125-.500	2.030	1,000
RABX1004000	1/4-28x4"	**HWH	#5	.125-.500	3.030	500
RABX1647000	1/4-28x5"	*HWH	#5	.125-.500	4.030	250
RABX1432000	1/4-28x6"	*HWH	#5	.125-.500	5.030	250
RABX1619000	1/4-28x8"	*HWH	#5	.125-.500	7.030	150

* 3/8" Bonded Washer , ** 5/16" Across Flats HWH



PRIME SOURCE
Drywall Screws
Bugle Fine



- For attaching gypsum board to 25-20 gauge steel studs
- Bugle head No. 2 Reduced Phillips Recess

Item #	Size	Box Qty.
PRMFS118	6X1½	10M
PRMFS114	6X1¼	8M
PRMFS1145	6X1¼	5#
PRMFS158	6X1½	5M
PRMFS1585	6X1½	5#
PRMFS200	7X2	3.5M

PRIME SOURCE
Drywall Screws
Bugle Coarse



- For attaching gypsum board to wood studs
- Bugle head No. 2 Reduced Phillips Recess

Item #	Size	Box Qty.
PRMCS118	6X1½	10M
PRMCS114	6X1¼	8M
PRMCS1145		5#
PRMCS158	6X1½	5M
PRMCS1585	6X1½	5#
PRMCS6200	6X2	3.5M
PRMCS62005	6X2	5#
PRMCS212	8X2½	2.5M
PRMCS2125	8X2½	5#
PRMCS300	8X3	2M
PRMCS3005	8X3	5#

PRIME SOURCE
Drywall Screws
Trim Head



- For attaching wood trim and base over gypsum board to light gauge steel studs or wood substrate
- No. 1 or 2 Square Recess

Item #	Size	Box Qty.
PRMTH1585	6x1½	5#
PRMTH2145	6X2¼	5#

PRIME SOURCE
Drywall Screws
Pan Framer



- For attaching 25-20 gauge steel track to 25-20 gauge steel studs
- With serrations to reduce spin out
- No. 2 Reduced Phillips Recess

Item #	Size	Box Qty.
PRM7165	7X7/16	5#

PRIME SOURCE
Drywall Screws
Drywall Laminator



- For attaching gypsum board to gypsum board
- No. 2 Phillips Recess

Item #	Size	Box Qty.
PRMLS10112	10X1½	5M
PRMLS101125	10x1½	5#

PRIME SOURCE
Drywall Screws
Modified Truss



- For attaching metal lath in stucco and other applications to wood or 25-20 gauge steel studs
- No. 2 Reduced Phillips Recess

Item #	Size	Box Qty.
PRMMT812	8X½	10M
PRMMT8125	8X½	5#
PRMMT114	8X1¼	5M
PRMMT1145	8X1¼	5#

PRIME SOURCE
Drywall Screws
Slotted Hex Washer Head



- Self-piercing needle point penetrates sheet metal from 0.0209 to 0.0358
- Twin lead threads assure fast action and reduce driving torque and strip-out problems
- Recommended for HVAC, electrical, plumbing, framing and sheet metal
- Zinc plated

Item #	Size	Box Qty.
--------	------	----------

¼" Drive

PRMHW4812	8X½	10M
PRMHW48125	8X½	5#
PRMHW4834	8X¾	10M
PRMHW48100	8X1	8M
PRMHW48112	8X1½	5M
PRMHW48200	8X2	3M

5/16" Drive

PRMHW510100	10X1	5M
PRMHW510112	10X1½	3M
PRMHW5101125	10X1½	5#
PRMHW510200	10X2	2M
PRMHW5102005	10X2	5#



PRIMESOURCE
Self-Drilling Screws
Bugle Head



- For attaching gypsum board to 20-14 gauge steel studs
- No. 2 Reduced Phillips Recess
- Available in zinc and black phosphate

Item #	Size	Box Qty.
--------	------	----------

Zinc

PRMSDZ258	8X2½	2M
-----------	------	----

Black Phosphate

PRMSD114	6X1¼	8M
PRMSD1145	6X1¼	5#
PRMSD158	6X1½	5M
PRMSD1585	6X1½	5#
PRMSD178	6X1¾	4M
PRMSD1785	6X1¾	5#
PRMSD238	8X2¾	3M



PRIMESOURCE
Self-Drilling Screws
Trim Head



- For attaching wood trim over gypsum to 20-14 gauge metal
- No. 1 or 2 Square Recess

Item #	Size	Box Qty.
--------	------	----------

PRMTHDZ2145	6X2¼	5#
-------------	------	----



PRIMESOURCE
Self-Drilling Screws
Pancake Framer



- For attaching 20-14 gauge steel track to 20-16 gauge steel studs
- No. 2 Reduced Phillips Recess

Item #	Size	Box Qty.
--------	------	----------

PRMPPH10585	10X¾	5#
-------------	------	----



PRIMESOURCE
Self-Drilling Screws
Low Profile Truss



- Low profile 20-16 gauge framer
- No. 10 diameter for added shear strength
- With serrations to reduce spin out
- No. 2 Reduced Phillips Recess

Item #	Size	Box Qty.
--------	------	----------

PRMFT1034	10x¾	7.5M
-----------	------	------



PRIMESOURCE
Self-Drilling Screws



Modified Truss

- For attaching metal lath in stucco and other applications 20 20-16 gauge steel studs
- No. 2 Reduced Phillips Recess

Item #	Size	Box Qty.
--------	------	----------

PRMMTD812	8x½	10M
PRMMTD8125	8X½	5#
PRMMTD8114	8X1¼	6M
PRMMTD81145	8X1¼	5#
PRMMTD1034	10X¾	5M



PRIMESOURCE
Self-Drilling Screws



**Hex Washer Head 1/4" Dr.
#2 Drilling Point**

- Metal to metal fastening used in sheet metal and light steel framing
- Very common in HVAC duct work assembly

Item #	Size	Box Qty.
--------	------	----------

PRMHWD812	8X½	10M
PRMHWD834	8X¾	10M



PRIMESOURCE
Self-Drilling Screws



**Hex Washer Head 5/16
Drive #3 Drilling Point**

- Metal to metal fastening used in medium gauge metal to metal framing
- Commonly used by sheet metal and HVAC contractors and fabricators

Item #	Size	Box Qty.
--------	------	----------

PRMHWD1012	10X½	8M
PRMHWD1034	10X¾	6M
PRMHWD10345	10x¾	5#
PRMHWD10100	10X1	5M
PRMHWD101005	10X1	5#
PRMHWD101125	10X1½	5#



PRIMESOURCE
Self-Drilling Screws



3/8 Drive #3 Drilling Point

- Metal to metal fastening for heavy gauge metal attachments
- Up to 3/8" thickness

Item #	Size	Box Qty.
--------	------	----------

PRMHWD14100	14X1	3M
-------------	------	----



PRIMESOURCE
Self-Drilling Screws



**Hex Washer Head 5/16
Drive #3 Drilling Point**

- Metal to metal fastening used in sheet metal to attach purlins and channels to structural studs
- Commonly used in up to 5 gauge steel

Item #	Size	Box Qty.
PRMHWD120345	12X3/4	5#
PRMHWD12100	12X1	3M
PRMHWD121005	12X1	5#
PRMHWD121125	12X1 1/2	5#
PRMHWD122005	12X2	5#

PRIMESOURCE
Self Drilling Screws



**Hex Washer Head W/ Neo-
prene Washer**

- For use in metal building applications where moisture needs to be sealed out by using a neoprene bonded washer
- 5/16" Drive #3 Drilling Point

Item #	Size	Box Qty.
PRMHDW10100	10X1	5m

PRIMESOURCE
Wood Working Screws



- Use for attaching wood to wood
- Recommended for cabinet and general woodworking
- an interior fastener not recommended for outdoor decking
- Bugle head No. 2 Reduced Phillips Recess
- Yellow Zinc

Item #	Size	Box Qty.
PRMGS158	6X1 1/8	5M
PRMGS1585	6X1 1/8	5#
PRMGS200	7X2	3.5M
PRMGS2005	7X2	5#
PRMGS212	8X2 1/2	2.5M
PRMGS2125	8X2 1/2	5#
PRMGS300	8X3	2M
PRMGS3005	8X3	5#
PRMGS400	10X4	1M
PRMGS4005	10X4	5#

PRIMESOURCE
Exterior Screws



PrimeGuard Plus

- Proprietary polymer coating
- Bugle head, gold color
- Type 17 point

Item #	Size	Drive	Box Qty.
PRMP158STGD	8x1 1/8	Star T-20	5#
PRMP3STGD	9X3	Star T-25	5#

PRIMESOURCE
Acoustical Fasteners



Eye Lag Screws

- Primarily used for hanging ceiling grid into wood joists

Item #	Size	Box Qty.
PRMEL3	1/4X3	1M

PRIMESOURCE
Acoustical Fasteners



**Self Drilling Eye Lag
Screws**

- Primarily used for hanging suspended ceiling grid into metal studs

Item #	Size	Box Qty.
PRMELDZ2	1/4X2	1M

PRIMESOURCE
Common Nails



Grip-Rite®

- Most popular nail and versatile style
- For construction, carpentry and framing
- Larger shank provides greater resistance to bending

Item #	Length (in.)	Size	Gauge	Head (in.)	Approx Count per Lb.	UoM
--------	--------------	------	-------	------------	----------------------	-----

Bright Smooth Shank

PRM6C	2	6D	11 1/2	1 7/64	167	Ea
PRM8C	2 1/2	8D	10 1/4	9/32	101	Ea
PRM12C	3 1/4	12D	9	5/16	61	Ea
PRM16C	3 1/2	16D	8	1 1/32	47	Ea

Hot Dipped Galv. Smooth Shank

PRM8HGC	2 1/2	8D	10 1/4	9/32	101	
PRM10HGC	3	10D	9	5/16	66	
PRM12HGC	3 1/4	12D	9	5/16	61	
PRM16HGC	3 1/2	16D	8	1 1/32	47	



PRIMESOURCE
Duplex Nails
Grip-Rite®



- For temporary construction where nail removal is required, such as concrete forming and scaffolding
- Smooth, uncoated shank and double head ease removal (second head remains exposed)

Item #	Length (in.)	Size	Gauge	Head (in.)	Approx Count per Lb.
--------	--------------	------	-------	------------	----------------------

Bright Double-head Shank

PRM6DUP	27/64	6D	11 1/2	3/16/17/64	156
PRM8DUP	25/8	8D	10 1/4	15/64/9/32	90
PRM16DUP	3 1/2	16D	8	9/32/11/32	45



Vinyl Coated Sinkers



- For construction, carpentry and framing
- Checkered countersunk head designed to sink flush with surface
- Vinyl-coated smooth shank for easier nailing and firmer holding power

Item #	Size	Length (in.)	Gauge	Head (in.)	Approx Count per Lb.
--------	------	--------------	-------	------------	----------------------

PRM8CTDSKR	8D	2 3/8	11 1/2	17/64	153
PRM12CTDSKR	12D	3 1/8	10	5/16	81
PRM16CTDSKR	16D	3 1/4	9	11/32	64



Box Nails
Grip-Rite®



- For construction, carpentry, and framing
- Thinner shank reduces wood splitting

Item #	Length (in.)	Size	Gauge	Head (in.)	Approx Count per Lb.
--------	--------------	------	-------	------------	----------------------

Hot Dip Galv, Smooth Shank

PRM6HGBX	2	6D	12 1/2	17/64	236
----------	---	----	--------	-------	-----



Joist Hanger Nails
Grip-Rite®



- For attaching joist hangers to wood studs
- Short, heavy gauge nail provides increased holding power without fully penetrating wood

Item #	Length (in.)	Gauge	Head (in.)	Approx Count per Lb.
--------	--------------	-------	------------	----------------------

Hot Dipped Galv

PRM114HGJST	1 1/4	9	5/16	149
PRM112HGJST	1 1/2	9	5/16	125

PRIMESOURCE
Roofing Nails
Grip-Rite®



- For applying roofing asphalt shingles, insulation board, and felt-to-wood substrates
- Large head and heavier shank gauge provide greater holding power
- Electrogalvanized nail also appropriate for use with vinyl siding

Item #	Size (in.)	Gauge	Head Size (in.)	Approx Count per Lb.
--------	------------	-------	-----------------	----------------------

PRM134EGRFG	1 3/4	11	7/16	152
-------------	-------	----	------	-----



Anchor J-Bolts

- A307 steel
- Includes Nut - No Washer



Item #	Size (in.)	Finish
JB126	1/2x6	Plain
JB128	1/2x8	Plain
JB1210	1/2x10	Plain
JB1210HDG	1/2x10	Hot-Dipped
JB1212	1/2x12	Plain
JB3410	3/4x10	Plain
JB3412	3/4x12	Plain
JB588	5/8x8	Plain
JB5810	5/8x10	Plain
JB5810HDG	5/8x10	Hot-Dipped
JB5812	5/8x12	Plain
JB5812HDG	5/8x12	Hot-Dipped



Brad Nails

Stainless Steel



Item #	Size (in.)	Gauge	Qty.
STOFANB16200SS	2	16	2.5M/Box
STOFANBMH18200SS	2	18	5M/Box



FANACO® FASTENERS
Angle Finish Nails

15 Gauge

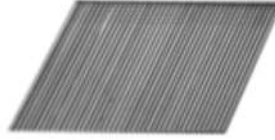

Item #	Size (in.)	Finish	Qty.
STOFANDA17B	1½	Bright	4M/Box
STOFANDA17G	1½	Galv.	4M/Box
STOFANDA21B	2	Bright	4M/Box
STOFANDA21G	2	Galv.	4M/Box
STOFANDA25B	2½	Bright	4M/Box
STOFANDA25G	2½	Galv.	4M/Box

FANACO® FASTENERS
Galv. Coil Roofing Nails

15 Degree Wire Collated



Item #	Size	Qty.
STOFANCR1D	7/8"x.120	7.2M/Box
STOFANCR2D	1"x.120	7.2M/Box
STOFANCR3D	1¼"x.120	7.2M/Box
STOFANCR4D	1½"x.120	7.2M/Box
STOFANCR5D	1¾"x.120	7.2M/Box

FANACO® FASTENERS
Siding/Fencing Nails

15 Degree Wire Collated

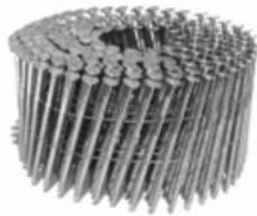

Item #	Size	Desc.	Qty.
STOFANAC7DREG45	23/16"x.092	Ring Shank - Electro Galv.	4.5M/Box

FANACO® FASTENERS
Fine Wire Staples

Item #	Qty.
STOFANA1138G	5M/Box



FANACO® FASTENERS
N-Type Medium Crown Staples

16 Gauge

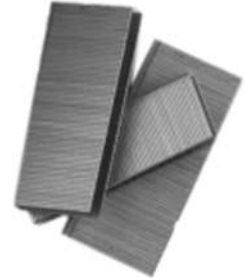

Item #	Size	Finish	Qty.
STOFANN17G	7/16" Crown x 1½" Leg	Electro. Galv.	10M/Box



PASLODE
Fuel Powered Framing Nailer



- Redesigned nose — For toe-nailing at any angle
- Portable, freedom on the jobsite without hoses or compressors
- Powerful enough to drive 3-1/4" nails in the toughest lumber
- Tool-less nail adjustment changes nail depth in an instant
- Nail lockout feature prevents blank fires
- Tool-free depth of drive adjustment
- Compact size fits between 16" o.c. studs, joists and roof trusses

Item #	Model	Weight (lbs.)	Nailer Capacity
PA902200	CF325	7.5 w/battery	1 strip (48 nails)

PASLODE
Fuel Powered 16 Ga. Straight Finish Nailer



- No hoses or compressors to drag around
- Open line of site, shoots where you want it to
- Depth of drive prevents wood damage.
- Powerful, drives 3/4"-2-1/2" nails into the hardest woods
- No mar tip protects wood

Item #	Model	Weight (lbs.)	Nailer Capacity
PA902000	CDLS STR	4.9 w/battery	100 (2 strips)



PASLODE

Fuel Powered 16 Ga. Angled Finish Nailer



- No hoses or compressors to drag around
- Open line of site, shoots where you want it to
- Depth of drive prevents wood damage.
- Angled magazine—Fits in tight spots
- Powerful, drives 3/4" - 2-1/2" nails into the hardest woods
- No mar tip protects wood

Item #	Model	Weight (lbs.)	Nailer Capacity
PA900600	CDLS ANG	4.9 w/battery	100 (2 strips)

PASLODE

Fuel Powered 18 Ga. Brad Nailer



- Adjustable Work Contact Element—Provides control of nail setting depth
- Quick Clear Nose—Should nail jam occur
- Lightweight and Well Balanced—4.9 lbs. A more maneuverable tool with less wrist and arm fatigue
- Narrow No Mar Tip—Provides for easy access to confined areas and permits precise placement of fasteners
- Sequential Operation—Drives 2-3 nails per second
- Powerful Motor—Drives 5/8" to 2" fasteners into the hardest woods
- Comfortable Sure-Grip Handle & Soft Trigger—Provides greater comfort and less fatigue
- Side Loading Magazine—Easier loading and unloading

Item #	Model	Weight (lbs.)	Nailer Capacity
PA901000	Cordless 18 ga. Brad Nailer	4.9	2 strips (100 pins)

PASLODE

PowerMaster Plus™ 30 Degree Strip Nailer



- Durable And Reliable—Rugged aluminum housing stands up to the demands of the job in any kind of weather
- Unmatched Power-to-Weight Ratio—All the power needed to drive into engineered lumber, yet still is comfortable to use
- Ergonomic Design—Provides better balance and low recoil
- Adjustable Work Contacting Element—Depth-of-drive adjustment on the tool saves time and energy
- Compact Size—13.3 inch height fits between joists and studs
- Drives 2" - 3-1/2" nails with ease

Item #	Model	Weight (lbs.)	Nailer Capacity
PA501000	F350-S	8.4	74-84 (2 strips)

PASLODE

30° Positive Placement® Nailer



Metal Connector

- Adjustable depth of drive ensures nail drives flush with hardware
- Smart Lever™ automatically adjusts nail length
- Sequential trigger for accurate placement
- 2-strip magazine, less reloading
- Probing tip targets metal strap hole easily
- Use with Paslode head-marked nails for easy nail identification
- Nail Range 1", 1-1/2", 2-1/2"

Item #	Model	Weight (lbs.)	Nail Capacity
PA500855	F250S-PP	8.5	2 Strips

PASLODE

Straight Finish Air Nailer



16 Gauge -20° Angled Collation

- Compact, open line of sight shoots where you want it to even in tight spots
- Reliable power, delivers consistent drive energy in all types of wood
- 16 gauge reduces wood splitting and nail visibility
- Powerful performer drives 3/4"-2-1/2" nails into the hardest woods

Item #	Model	Weight (lbs.)	Nail Capacity
PA501680	T250S-F16	3.9	100 (2 strips)

PASLODE

T250S-F16

16 Gauge Pneumatic Straight Finish Nailer



- Directional Exhaust Cap—Easily change the direction of exhaust/dust
- Soft Textured Grip—Decreases user fatigue during all day use
- Tool-Free Depth of Drive Adjustment—Simple, fast control of nail depth
- Nail Lockout—Nail lockout at 10 nails prevents blank fire damage to work surface
- Compact Size—Compact, angled trim tool reaches into tighter spots than straight finish tools
- Lightweight—Less than 4 lbs., reduces user fatigue
- Durable and Reliable—Rugged design holds up to the demands of the jobsite

Item #	Model	Weight (lbs.)	Nailer Capacity
PA500910	T250A-F16	3.8	100 (2 strips)



PASLODE
Brad Finish Air Nailer
18 Gauge

- Prevents wood splitting—18 Gauge leaves small holes
- Slender, long-nose design reaches tight spots and precisely places nail
- Depth of drive adjustment controls nail setting depth
- Quick clear nose for easy access to nails
- Protects wood—No mar tip protects expensive wood
- Performs—Drives 5/8"-2" finish nails



Item #	Model	Weight (lbs.)	Nail Capacity
PA500959	T200-F18	2.1	100 (2 strips)

PASLODE
R-175C
Roofing Nailer

- Heavy Duty Wear Plates-Protect tool housing
- Comfort Grip-Increased durability and user comfort
- Single-Door Magazine-Provides fast and easy loading
- Shingle Guide-Allows for accurate nail placement
- Universal-15 degree. Accepts all standard roofing coil nails, smooth and ring shank 7/8" - 1-3/4"



Item #	Part #	Model	Weight (lbs.)	Nailer Capacity
PA405000	PA405000	R-175C	5.5	120

PASLODE
Brite 30° Framing Nails
Round Head

- 20% more nails per strip than competitive round head strip nails - means less reloading
- Strips won't break, even in rainy weather - no flying debris

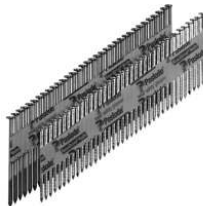

Item #	Length (in.)	Dia. (in.)	Shank	Box Qty.
PA650272	2	.113	Smooth	5,000
PA650273	2	.113	Ring	5,000
PA405253	2½	.131	Smooth	3,000
PA650237	2¾	.113	Smooth	5,000
PA650238	2¾	.113	Ring	5,000
PA650236	3	.120	Smooth	2,500
PA650210	3	.131	Smooth	2,500
PA650239	3¼	.131	Smooth	2,500

PASLODE
HDG 30° Framing Nails
Round Head

- Paslode's Hot Dipped Galvanized Plus nails offer premium corrosion in all pressure treated lumber such as ACQ and MCQ
- Polymer coating reduces staining and streaking by 80% compared to traditional hot dipped galvanized nails



Item #	Length (in.)	Dia (in.)	Shank	Box Qty.
PA650381	2	.113	Ring	2,000
PA650382	2¾	.113	Smooth	2,000
PA650383	2¾	.113	Ring	2,000
PA650384	3	.120	Smooth	2,000
PA650385	3	.120	Ring	2,000
PA650386	3	.131	Smooth	2,000
PA650387	3	.131	Ring	2,000
PA650388	3¼	.131	Smooth	2,000
PA650476	3½	.131	Smooth	2,000

PASLODE
Galvanized Straight Finish Nails
16 Gauge

- The stronger, stiffer 16 gauge nail ensures consistent drivability
- Galvanized for superior corrosion resistance
- Chisel point reduces wood splitting
- Smaller 16 gauge nail hole is ideal for any finish work



Item #	Length (in.)	Box Qty.
PA650281	1	2,000
PA650282	1¼	2,000
PA650283	1½	2,000
PA650284	1¾	2,000
PA650285	2	2,000
PA650287	2½	2,000

PASLODE
Galvanized Angled Finish Nails
16 Gauge

- Use with Paslode 20° 16 gauge angled finish nailers
- Galvanized for superior corrosion resistance
- Chisel point reduces wood splitting
- Smaller 16 gauge nail hole is ideal for any finish work



Item #	Length (in.)
PA650230	1¼
PA650231	1½
PA650232	2½



PASLODE

Galvanized Brad Nails

18 Gauge

- Galvanized for superior corrosion resistance
- Chisel point reduces wood splitting
- Smaller 18 gauge nail for premium workmanship



Item #	Length (in.)	Box Qty.
PA650212	1	2,000
PA650213	1¼	2,000
PA650214	1½	2,000
PA650215	2	2,000

PASLODE

Brite Positive Placement®

Metal Connector Nails

- For installing joist hangers, straps, framing anchors/ties, seismic/hurricane ties
- Full head, smooth shank
- Head marked for easier nail identification
- ICC-ES Recognized, ER-2126
- Heat treated, paper tap collation



Item #	Length (in.)	Dia. (in.)	Collation	Box Qty.
PA650025	1½	.131	35° Strip	4,000
PA650026	1½	.148	35° Strip	3,000
PA650027	2½	.148	31° Strip	2,500
PA650028	2½	.162	31° Strip	2,000

PASLODE

Galv. Positive Placement®

Metal Connector Nails

- For installing joist hangers, straps, framing anchors/ties, seismic/hurricane ties
- Full head, smooth shank
- Head marked for easier nail identification
- ICC-ES Recognized, ER-2126
- Heat treated, paper tap collation



Item #	Length (in.)	Dia. (in.)	Collation (deg.)	Box Qty.
PA650014	1½	.148	35	3,000

PASLODE

CF325 Fuel + Nail Combo Pack

Brite 30° Round Head

- For use with Paslode CF325 Cordless Framing Nailer only
- (1) Quicklode™ fuel cell with every 1,000 30° paper tape offset full head nails



Item #	Length (in.)	Dia. (in.)	Shank	Box Qty.
PA650522	2¾	.113	Smooth	1,000
PA650523	2¾	.113	Ring	1,000
PA650525	3	.131	Smooth	1,000
PA650535	3¼	.131	Smooth	1,000

PASLODE

CF325 Fuel + Nail Combo Pack

GalvGuard™ 30° Round Head

- For use with Paslode CF325 Cordless Framing Nailer only
- (1) Quicklode™ fuel cell with every 1,000 30° paper tape offset full head nails
- GalvGuard™ Premium Corrosion Protection for pressure treated lumber
- Polymer coating reduces staining and streaking by 80% compared to traditional hot dipped galvanized nails
- Approved for use in pressure treated lumber such as ACQ and MCQ
- IRC R319.3 code approved for use in pressure treated lumber in accordance with ASTM A 153



Item #	Length (in.)	Dia. (in.)	Shank	Box Qty.
PA650526	2¾	.113	Ring	1,000
PA650563	3	.120	Smooth	1,000

PASLODE

16 Gauge Brite Staples

1/2" Standard Crown

- Special coating bonds to wood for superior holding power
- Extra strong, won't fall apart if dropped



Item #	Length	Box Qty.
PA400026	1"	16,500



PASLODE
**No Mar Tips For
Angled Finish Nailers**

- Pack of three replacement No Mar Tips for use with Paslode's 16-Gauge angled finish nailers
- Used for up close precision nailing without damaging materials
- Features: Helps to prevent surface damage of materials while driving nails
- Weight - 2.0 lbs.



Item #
PPA219236

PASLODE
Tall Red Framing Fuel Cell

Paslode's Cordless Framing Nailers

- Maximum performance for Paslode's IMCT Fuel Powered Cordless Framing Nailer
- Ready to use when cap is snapped from front-to-back
- Not for use with the New CF325 Fuel Powered Cordless Framing Nailer



Item #	Number of Shots
PA401301	1,100 - 1,300 nails

PASLODE
Short Yellow Trim Fuel Cell

Paslode's Finish Nailers

- Maximum performance for Paslode's Fuel Powered Cordless Finish and Brad Nailers
- Ready to use when cap is snapped from front-to-back



Item #	Number of Shots
PA650039	1,200 nails (approx.)

PASLODE
Oval Battery

- For use in all Paslode Fuel Powered nailers
- Charges in 2 hours



Item #	Battery Charge Life
PPA404717	4,000 nails

PASLODE
Cordless Tool Cleaner

- Powerful spray removes dirt, moisture and oxides without residue
- Safe for Internal Electronic Components
- Cleans and Dries Quickly
- Non-CFC, Plastic Safe
- Available in 12 oz. cans



Item #
PPA219348

PASLODE
Cordless Nailer Lubrication Oil

- Conditions and lubricates your Paslode Cordless tool for consistent tool performance
- 4 oz. bottle
- For use with all cordless tools



Item #
PPA401482

PASLODE
**Fuel Powered
Cordless Stapler**

**16 Gauge - Standard
Crown**

- Cordless, the freedom of no hoses or compressors
- Less set up time means higher productivity
- Quick-clear feature provides easy access to nose to reduce downtime
- Depth of drive adjustment provides precise control of staple depth
- Powerful, drives 3/4" - 2" standard crown (1/2") 16 gauge staples
- Floating tip for siding over softwall sheathing or Celotex®



Item #	Model	Weight (lbs.)	Staple Capacity
PA900078	IM200-S16SS	6.3 w/battery	150 (2 strips)

PASLODE
Construction Stapler

Pneumatic

- Great for roofing, house wrap, wire lath and sheathing
- Drives 5/8"- 1-1/2" wide crown (15/16") 16 gauge staples
- Tool-less quick clear nose removes jams easily



Item #	Model	Weight (lbs.)	Staple Capacity
PA501270	S150-W16R	4.9	150



PASLODE
Framing Stapler
Pneumatic

- Great for floor decking, roof sheathing, plywood sheathing and insulation
- Versatile, drives 3/4" - 2" standard crown staples
- Quick clear nose to clear jams quickly and easily
- Vinyl siding guide sold separately



Item #	Model	Weight (lbs.)	Staple Capacity
PA501230	S200-S16	4.9	150

PASLODE
Narrow Crown Stapler
Pneumatic

- Lightweight and durable tool for rough in-plant usage
- Secures joint to enable you to handle truss prior to plate pressings
- Fires wide crown staples for industrial applications



Item #	Model	Weight (lbs.)	Staple Capacity
PA501260	S150-N18	4.9	150

PASLODE
Insulation Sheathing Stapler
Pneumatic

- Top load magazine—reloads easily and reduces nail waste
- Great for housewrap, insulation, wire lath and sheathing
- Drives 3/4" - 2" wide crown (15/16") 16 gauge staples
- Tool-less quick clear nose removes jams easily



Item #	Model	Weight (lbs.)	Staple Capacity
PA501265	S200-W16	4.9	150

PASLODE
No Mar Work Contacting Element
For the F-350

- Prevents the marring of work surfaces when installing siding or deck boards
- Includes one extra replacement rubber tip



Item #
PPA219228

PASLODE
Industrial Staples GSN Series

3/16" Crown - 18 Gauge

- Galvanized finish
- 5000 per box

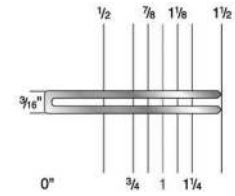

Item #	Length (in.)
PA092055	1/8
PA092056	1
PA092057	7/8
PA092058	3/4
PA092059	5/8
PA092062	1/2
PA650341	1 1/4
PA650342	1 1/2

PASLODE
Galvanized Staples
1/2" Standard Crown-16 Gauge

- Galvanized for corrosion protection
- Extra strong, won't fall apart if dropped



Item #	Length (in.)	Box Qty.
PA0T5240	3/4	21,000
PA0T5242	1	16,500
PA0T5238	1 1/4	13,500
PA0T2695	1 1/2	10,500
PA0T2250	1 3/4	9,000
PA0T2258	2	7,500

PASLODE
Galvanized Staples
15/16" Wide Crown 16 Gauge

- Wider crown for superior holding power
- Galvanized protection



Item #	Length (in.)	Box Qty.
PA0T2851	5/8	25,500
PA404068	3/4	9,000
PA404069	7/8	9,000
PA404070	1	9,000
PA404071	1 1/4	9,000
PA0T2855	1 1/2	10,500
PA403471	2	7,500



PASLODE

Cordless Stapler Stick Battery

- For use with the Fuel Powered Cordless 16 Gauge Stapler (900078NT)
- Battery Charge Life: 4,000 staples
- Charges in 2 hours



Item #

PA402500

PASLODE

Battery Charger

- Charges batteries in 2 hours
- Voltage Sensing Electronics Prevent Overcharging
- AC battery charger
- Accepts Paslode oval and stick batteries



Item #

PPA900200

PASLODE

Tall Yellow Fuel Cell

- Maximum performance for Paslode's 16 ga. Fuel Powered Cordless Stapler
- Ready to use when cap is snapped from front-to-back
- Will shoot approx. 2,400 nails/staples



Item #

Number of Shots

PA404479 2,400 staples/nails (approx.)

PASLODE

High Altitude Fuel Cell

- Designed to improve Paslode's cordless finish nailer and stapler performance in high altitudes
- High altitude valve for elevation 4,000 to 9,000 feet
- Easily installs on Paslode yellow fuel
- Not for use with Paslode red framing fuel



Item #

PA219247



FANACO® FASTENERS

Gun Nails

21 Degree Plastic Collated



Item #	Size	Desc.	Qty.
STOFAN238120EG	2 ³ / ₈ "x.120	Electro Galv.	5M/Box
STOFAN3131EG	3"x.131	Electro Galv.	4M/Box
STOFAN314131EG	3 ¹ / ₄ "x.131	Electro Galv.	4M/Box
STOFAN314131HDG	3 ¹ / ₄ "x.131	Hot Dip Galv.	4M/Box
STOFAN312131EG	3 ¹ / ₂ "x.131	Electro Galv.	4M/Box
STOFAN212131	2 ¹ / ₂ "x.131	Vinyl Coated	5M/Box
STOFAN214148	2 ¹ / ₂ "x.148	Vinyl Coated	5M/Box
STOFAN238120	2 ³ / ₈ "x.120	Vinyl Coated	5M/Box
STOFAN3131	3"x.131	Vinyl Coated	4M/Box
STOFAN3148	3"x.148	Vinyl Coated	4M/Box
STOFAN314131	3 ¹ / ₄ "x.131	Vinyl Coated	4M/Box
STOFAN314148	3 ¹ / ₄ "x.148	Vinyl Coated	4M/Box
STOFAN312162	3 ¹ / ₂ "x.162	Vinyl Coated	3M/Box

FANACO® FASTENERS

Ring Shank

21 Degree Plastic Collated



Item #	Size	Desc.	Qty.
STOFAN238120R	2 ³ / ₈ "x.120	Ring Shank - Vinyl Coated	5M/Box
STOFAN238120REG	2 ³ / ₈ "x.120	Ring Shank - Electro Galv.	5M/Box

FANACO® FASTENERS

Positive Placement Nails

34 Degree Paper Collated



Item #	Size	Finish	Qty.
STOFAN34112148HTEG	1 ¹ / ₂ "x.148	Heat Treated Electro Galv.	2M/Box



ITW REDHEAD

T3 Fastening System

Single-Shot Fuel Powered Ramset®



- No licensing or special training needed
- 10x faster than drilling and anchoring
- Lower recoil reduces operator fatigue
- Quite enough to work in occupied buildings

Item #
RAT3SS

ITW REDHEAD

T3 Fastening System

Magazine Fuel Powered Ramset®



- 25% more power
- Larger diameter pin (.125) for higher stick rate
- Deep leg track capability
- One step fuel injected system
- 15-pin strip, 45-pin magazine

Item #
RAT3MAG

ITW REDHEAD

Fuel and Pin Packs

Gas Tool Fasteners

- Each Fuel Cell contains 1000 shots
- Bigger pin (.125 dia) means better success rate
- New 15 pin strip means less loading and more shooting
- Our new patented Point Collation virtually eliminates jams
- Fuel cell vs. powder load comparison: The average cost savings to deliver 1000 shots for the Ramset T3 fuel cell is between 50-70% less expensive compared to powder
- 1000 per box



Item #	Desc.
RAT3012	1/2" steel pin with T3 fuel cell
RAT3034B	3/4" concrete pin with T3 fuel cell
RAT3034S	3/4" step shank pin with T3 fuel cell
RAT3100	1" concrete pin with T3 fuel cell

ITW REDHEAD Mechanical Pin with Washer



Gas Tool Fasteners

- Used for the attachment of light gage metal to concrete and steel such as HVAC duct strap to concrete
- Plated pin pre-assembled to a 1/2" domed washer (500 per box)
- Shank diameter = .125 Step Pin .104/.118
- Head diameter = .300 (M012=.250)
- Will fit R150 & T3SS with optional work contact element P/N M150200

Item #	Desc.
RAM012	1/2" Plated step pin with domed washer
RAM034	3/4" Plated pin with domed washer
RAM034BB	3/4" Premium step pin with domed washer
RAM100	1" Plated pin with domed washer

ITW REDHEAD

Top Hat Pin

Gas Tool Fasteners

- Used for general purpose fastening to concrete
- 100 per box
- Shank diameter = .125 Head diameter = .300



Item #	Desc.
RAMP034TH	3/4" Plated pin with top hat

ITW REDHEAD

T3 Fuel Cartridges

T3SS and T3MAG

Ramset®

- Replaces conventional powder loads and drives more than 1000 pins
- Fuel injection means no additional steps of preparing a fuel cell
- Click the fuel cell in place and the tool is ready to go



Item #
RAT3FUEL

ITW REDHEAD

Fuel Cartridges

Ramset®

- Replaces conventional powder loads and drives more than 1000 pins
- Cell-T2, R150, E150 & M150



Item #
RAR-FUEL



ITW REDHEAD
**T3SS Extension Pole
Tool**
Ramset®

- Easy to operate Comfortable "motorcycle" grip replaces handbrake mechanisms
- Sturdy design 25% thicker than similar poles for greater support

Item #	Length (ft.)
RAEPOL6	6

ITW REDHEAD
Automatic Fastening Tools
TrakFast™



Speed:

No other fastening system works as well—or as fast—as TrakFast. It's three to five times faster than any other system. The tool holds 42 pins so the operator spends even less time reloading and more time fastening.

Ease of Use:

TrakFast's self-contained power source makes the tool easier and safer to use than powder or pneumatic tools. Because of TrakFast's unique vacuum return, there's no need to reset the piston after each firing.

No Licensing Required:

Unlike powder actuated tools, no special training or licensing is required.

Reduced Slipping on Work Surface:

Reach is extended, especially overhead, because the end of the nosepiece slips less when fastening to the work surface.

Durability:

The tool body is constructed of high-impact nylon. Fewer parts mean less maintenance. Fewer jams because of our patented guidance system for pins. Less downtime and less maintenance because there's no powder build-up.

Better Pin Guidance:

At the time of firing, the nose of the tool stays on the work surface, resulting in a better guided fastener. Operators see more successful fastenings right away.

No Recoil:

The tool actually absorbs the recoil so there is much less operator fatigue after a long day of fastening.

No Load Changes Required for Different Applications:

Unlike powder tools, there's no need to inventory a variety of load colors when using TrakFast for different applications. TrakFast's self-contained engine delivers consistent fastening force for concrete, block or steel.

Qty/Carton: 1

Item #
RATF1100

ITW REDHEAD
**Standard Black Strip Fuel/Pin
Packs**

1 Fuel Cell & 1,000 Pins
TrakFast™

- Qty/Carton: 1000

Item #	Desc.
RAFPP012S	½ in. Plated Steel Pin
RAFPP034B	¾ in. Black Pin
RAFPP100	1 in. Black Pin



ITW REDHEAD
**Breakaway Strip Fuel/Pin
Packs**

1 Fuel Cell & 1,000 Pins
TrakFast™

- Qty/Carton: 1000

Item #	Desc.
RAFPP112T	1½ in. Plated Pin



ITW REDHEAD
**Trakfast TekPin
Knurled Fastener**

- For attaching 14, 16, 18 Ga. stud to track and other metal to metal applications
- Excellent withdrawal & shear loads
- Knurls cinch connections tight
- Great for finish work because head drives flat
- Perfect for blocking and bracing applications



Item #	Desc.
RATEK034	¾" Helical Knurled Shank

ITW REDHEAD
Trakfast Plywood Pins

- For attaching plywood to metal studs
- 3 - 5 times faster than screw installation
- No worrying about electrical cords
- No set-up and tear down time
- No hassling with compressors or hoses
- Hardened steel pin ensures a clean penetration of the fastener — no dimpling of the stud
- Knurled helical shank gives the fastener superior holding values
- Zinc plated for corrosion resistance
- Shank Diameter: .100 dia. (before knurl) Head Diameter: .250



Item #	Desc.
RAPLY138	1¾" Helical Knurled Shank



ITW REDHEAD
TrakFast Fuel Cartridges

Ramset®

- Replaces conventional powder loads and drives more than 1000 pins

Item #
RATFUEL



ITW REDHEAD
Powder Fasteners

Semi Automatic

Advantages:

- Excellent balance-easy to use all day long
- Narrow nosepiece for hat track available-Part #27996

Specifications

- .27 caliber 10-shot strip loads 3 (green), 4 (yellow), 5 (red)
- Factory mutual system approved

Pin Capacity: 2-1/2" (3" w/washer)



Item #	Load Type	Max. Pin Length	Weight (lbs.)	Wt
RASA270	.27 Caliber 10-Shot Strip Loads	3" Straight Pin	5.45	534

ITW REDHEAD
Powder Fasteners

Semi Automatic
Ramset®

- 30% faster overhead attachment

Advantages:

- No cycling eliminates wasted loads-work faster and save money
- Super quiet-work in occupied buildings without disturbing occupants
- Weighs just 3 pounds-four pounds lighter than other manufacturer's tool. Increases productivity
- Easy to use-just position, then push to fire. No trigger. No broken cables. No pinched fingers

Specifications

- .27 caliber, 10-shot strip loads 3 (green), 4 (yellow), 5 (red)
- Pin Capacity Ceiling Clips: 1-1/4 in. (match nosepiece with pin)

Item #	Load Type	Max. Pin Length	Weight (lbs.)	Wt
RAVIPER	.27 Caliber, 10-Strip Loads	1 1/2"	4.5	3



ITW REDHEAD
D60

Powder Actuated Nailer

Advantages:

- Quick power adjustment-gives eight levels of power with only one load level for a variety of applications
- Rugged polyamide housing-reduces heat transfer and maximizes user comfort
- Soft, recoil-absorbing handle-for increased operator comfort
- Ramset Disc Technology-loads only advance after firing; eliminates 10-20% of load waste
- 5 year warranty



Item #	Load Type	Max. Pin Length	Weight (lbs.)
RAD60	.25 Caliber, 10 Shot Disc Loads	2 3/8" (2 1/2" with washer)	4.9

ITW REDHEAD
Hard Concrete and Steel Pins

Standard Powder Actuated
PowerPoint™

- Used for fastening into harder steel and concrete, premium steel and hard concrete pin
- 100 per box
- Shank diameter = .150 Head diameter = .300



Item #	Shank Length (in.)
RASP58	5/8
RASP34	3/4

ITW REDHEAD
Ramguard Pins

- Designed for use in treated lumber applications
- 100 per box
- Shank diameter = .145 Head diameter = .300



Item #	Shank Length (in.)
RA1516SDE	2 1/2 w/washer
RA1524SDE	3 w/washer



ITW REDHEAD
Drive Pins

Powder Actuated

ITW Ramset/Red head powder actuated fasteners are specifically fabricated to meet the exacting requirements of toughness and durability that enable them to penetrate dense concrete and structural quality steel.

Designed for use in concrete and structural steel applications. 100 pin pack

.300 head diameter drive pins

Shank diameter = .145



Item #	Shank Length in. (mm)
RA1503K	½ Knurled (12.7)
RA1506	¾ (19.1)
RA1508	1 (25.4)
RA1510	1¼ (31.8)
RA1512	1½ (38.1)
RA1514	2 (50.8)
RA1516	2½ (63.5)
RA1524	3 (76.2)

ITW REDHEAD
Drive Pins w/Washers

- Washer increases bearing surface against the material to be fastened
- 16 Ga. metal washer (100 per box)
- Shank diameter = .145 Head diameter = .300



Item #	Shank Length (in.)
RA1508SD	1
RA1510SD	1¼
RA1512SD	1-½
RA1514SD	2
RA1516SDC	2½
RA1524SDC	3

ITW REDHEAD
Top Hat Drive Pins
Powder Actuated

- Increases bearing surface against material to be fastened for improved attachment to inconsistent base materials
- 100 per box
- Shank diameter = .145 (SP58TH = .150) Head diameter = 8 mm (SP58TH = .300)



Item #	Shank Length (in.)
RASP58TH	5/8
RA1906	¾
RA1908	1

ITW REDHEAD
Hard Concrete and Steel Pins

Step Shank Powder Fastener

PowerPoint™

- Used for fastening into harder steel and concrete. Premium steel and hard concrete pin
- 100 per box
- Shank diameter = .150 / .180 Head diameter = .300



Item #	Shank Length (in.)
RASP100	1
RASP114	1¼
RASP112	1½
RASP178	1¾

ITW REDHEAD
1/4"-20 Threaded Studs

For applications that require removability, where shimming is required.

- Shank diameter = .145



Item #	Thread Length in. (mm)	Shank Length in. (mm)	Viper Nose-piece Required
RA1623WK	¾ (19.1)	½ Knurled (12.7)	2VP4125
RA1643W	¾ (19.1)	1 (25.4)	2VP4200

ITW REDHEAD
Hybrid Pin

Powered Fasteners

- For general purpose attachments to concrete
- 500 per box
- Shank diameter = .125 / .150 Head diameter = .300



Item #	Desc
RAM100BB	1" PowerPoint step shank pin with ½" domed washer & flute

ITW REDHEAD
3/8" Threaded Studs

For applications that require removability, where shimming is required.

- Shank diameter = .145
- Thread Length: 1" (25.4) mm



Item #	Shank Length in. (mm)
RA9190	1¼ (31.8)



ITW REDHEAD
Threaded Stud 1/4-20

Gas Tool Fasteners

- Used to attach electrical components to concrete where removability of the component is required
- Plated pin with top hat (500 per box)
- Shank diameter = .125



Item #	Thread Length (in.)	Shank Length (in.)
RA14STUD	1/2	3/4

ITW REDHEAD
Ceiling Clip Assemblies

Powdered Fasteners

- Designed for suspended ceilings and other overhead applications
- Fastener is preassembled to 14 Ga. angle clip for applications such as the hanging of ceiling wire to support ceiling grid.
- Shank diameter = .145 Head diameter = .300



Item #	Pin Length (in.)
RASDC-125C	1 1/4

ITW REDHEAD
One Hole Conduit Strap

Ramset®

- Used to attach conduit or armored cable to concrete
- 18 Ga conduit strap (100 per box)
- Shank diameter = .125/.150 Head diameter = .300



Item #	Desc.
RA38HSS10	3/8" Hole strap w/1" premium pin
RA12HSS10	1/2" Hole strap w/1" premium pin
RA34HSS10	3/4" Hole strap w/1" premium pin
RA10HSS10	1" Hole strap w/1 1/4" premium pin

ITW REDHEAD
Threaded Rod Hanger

Ramset®

- For suspended ceilings, piping and other items using 1/4 or 3/8 threaded rod
- 16 Ga. threaded rod hanger (100 per box)
- Shank diameter = .125/.150 Head diameter = .300



Item #	Desc.
RA14TRHSS10	1/4" Rod hanger w/1" premium pin
	3/8" Rod hanger w/1" premium pin

ITW REDHEAD
Threaded Rod Hanger

Gas Tool Fasteners

Ramset®

- The fasteners are designed for use in Ramset Single Shot Gas Tools (R150, T3SS)
- For suspended ceilings, piping and other items using 1/4 or 3/8 threaded rod
- 16 Ga. threaded rod hanger (100 per box)
- Shank diameter = .104/.125 Head diameter = .300



Item #	Desc.
RA14TRHMP034	1/4" Rod hanger with 3/4" plated pin
RA38TRHMP034	3/8" Rod hanger with 3/4" plated pin

ITW REDHEAD
One Hole Conduit Strap

Gas Tool Fasteners

Ramset®

- Used to attach conduit or armored cable to concrete
- 15 Ga. conduit strap (100 per box)
- Shank diameter = .125/.150 Head diameter = .300



Item #	Desc.
RA38HSP034	3/8" Hole strap with 3/4" plated pin (18 Ga.)



ITW REDHEAD

Tie Strap Holder

Gas Tool Fasteners Ramset®

- Used to install temporary lighting and secure low voltage cable to concrete, uses a standard cable tie up to 3/8" in width
- Fastener pre-assembled to a 22 Ga. tie strap holder (100 per box)
- Shank diameter = .104/.125 Head diameter = .300



Item #	Desc.
RATSHMP034	Tie strap holder with 3/4" plated pin

ITW REDHEAD

Semi Automatic Fasteners

- .25 caliber, 10-shot disc loads



Item #	Color	Wt
RA2D60	Brown	4.9
RA3D60	Green	4.9
RA4D60	Yellow	4.9

ITW REDHEAD

Powder Loads

ITW Ramset/Red Head powder loads and tools match tolerances to provide optimum power within recognized national velocity standards. Available in color-coded 10-load discs, 10-load strips, and 100-load boxes.

Powder Guide

Power level is designated by the load level number marked on each box; also by the color of the box and each powder load. As the number increases, the power level increases.

Case Color: Brass



Item #	Tool Model	Power Level	Color	Caliber	Packaging/Box
RA22CW	721-4170	2	Brown	0.22	100
RA32CW	721-4170	3	Green	0.22	100
RA42CW	721-4170	4	Yellow	0.22	100
RA3RS27	SA270, DX-350	3	Green	0.27	10 Strips
RA4RS27	SA270, DX-350	4	Yellow	0.27	10 Strips
RA5RS27	SA270, DX-350	5	Red	0.27	10 Strips
RA3RS25	DX-35	3	Green	0.25	10 Strips
RA4RS25	DX-35	4	Yellow	0.25	10 Strips
RA5RS25	DX-35	5	Red	0.25	10 Strips
RA6RS27	DX-451	6	Purple	0.27	10 Strips

ITW REDHEAD

Extension Poles

Quality Ramset extension poles provide the convenience of using powder actuated tools for overhead fastening without the need for scaffolding or ladders.



Advantages:

- Rubber "motorcycle" grip for operator comfort and to reduce recoil level
- Encased cable runs length of pole and connects hand lever with trigger-no rods to bend inside
- Delrin™ coupler on cable makes pole di-electric
- Top-quality hand lever and cable system requires only 15 pounds of pressure so cable doesn't stretch
- Lightweight cast aluminum housing fits tool snugly and provides tool protection

For use with:

- D60-our premier semi-automatic tool, featuring power level adjustment and no-waste disc loads
- SA270-high-quality .27 caliber strip tool for general purpose applications
- D45-most durable, high-power, semi-automatic tool for hard concrete and steel applications
- MD380-popular 3/8" head diameter tool
- AUTOFAST-the fastest, quietest tool we make; no cocking
- Hilti® DX36

Item #	Desc. (ft.)
RAPTSEMI6	8
RAPTSEMI8	6

ITW REDHEAD

Ramset Viper

Extension Poles

Ramset®

- Rubber "motorcycle" grip for operator comfort and to reduce recoil level
- Delrin™ coupler on cable makes pole di-electric
- Top-quality hand lever
- Lightweight cast aluminum housing fits tool snugly and provides tool protection
- Trigger bar adjusts easily for individual tools
- Adjustable in 1' increments

Item #	Length (ft.)
--------	--------------

Telescoping

RATVP0L612	6—12
------------	------



PNEUTEK

Steel Decking Tools

Stand-up Air-Safe®

- Ergonomic stand-up tool design for comfort, speed and convenience
- Uni-construction fasteners for highest shear strength and ease of inspection
- Fastens into unlimited steel thickness
- Lowest in-place fastener cost
- Highest corrosion resistant fasteners



Item #	Desc.
PIPT-400Z-ER1	1 1/2" Magazine, 1/2" Head Dia.
PIPT-1500Z-ER1	1 1/2" Magazine, 1/2" Head Dia.
PIPT-2000Z-ER1	1 1/2" Magazine, 1/2" Head Dia.

PNEUTEK

Portable Air Compressors



Item #	Description	Output
PIPC-2S13KES-20	Two-stage, 12.5 hp. Kohler engine	20 cfm @ 175 psig
PIPC-2S22KES-40	Two-stage 22 hp. Kohler engine	39.5 cfm @ 175 psig

PNEUTEK

Auxiliary Tank

- 17 gallon ASME tank assembly
- Equipped with pressure regulator, safety valve, male connector and female coupler



Item #
PIATA-17

Mechanical attachment of roof & pan-deck

Save time and money!

PNEUTEK 1/2" Head Dia. Fasteners



- Knurled fasteners for steel dock
- Pre-collated in color-coded strips of 10
- Easily loaded in magazine which holds 30 fasteners
- 2500 per carton
- Use these pins to attach four thicknesses of 20 Ga. steel deck or three to four of 16/18 Ga. to a steel substrate

Item #	Diameter (in.)	Length (in.)	Steel Substrate Thickness (in.)	For Tool No.
PISDK61075	.142	3/4	.113 to .155	PT-400Z
PISDK63075	.172	3/4	.155 to .250	PT-400Z, PT-1500Z
PIK64062	.182	5/8	.188 to .312	PT-1500Z
PIK66062	.199	5/8	.281 and up	PT-1500Z
PIK64075	.82	3/4	.188 to .312	PT-1500Z, PT-2000Z
PIK66075	.199	3/4	.281 and up	PT-1500Z, PT-2000Z

PNEUTEK

Air Hose

- 1/2" x 100 ft., 300 PSI air hose assembly
- 3/8" female coupler and 3/8" male connector



Item #
PIAHA-100

Call for a demo of the Pneutek System

Edge rents & repairs Pneutek.



Simpson Hardware Overview

General Categories of Wood Construction Connectors

(Refer to Simpson Strong-Tie Wood Construction Connectors product catalog for more details, options & specifications)



Concrete Connectors & Anchors

- MASA (Mudsill Anchors)
- SSTB/SB (Anchor Bolts)
- Other products like foundation anchors bearing plates, beam seats, . . .
- Refer to other chapter in this catalog for information on mechanical & chemical anchors

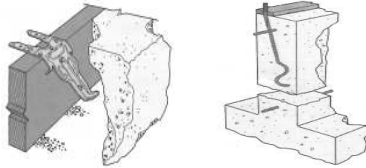

Holdowns & Tension Ties

- HDU (Holdowns)
- LTT/HTT (Tension Ties)
- Ask about other products like strap-tie Holdown, & Purlin anchors

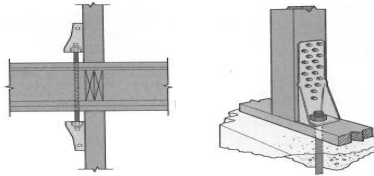

Caps & Bases

- AB/ABA/ABE/ABU (Adj. & Standoff Post Bases)
- CB/CBSQ (Column Bases)
- BC or AC (Post Caps)
- ECCQ/CCQ (Column Caps)
- ECC/CC

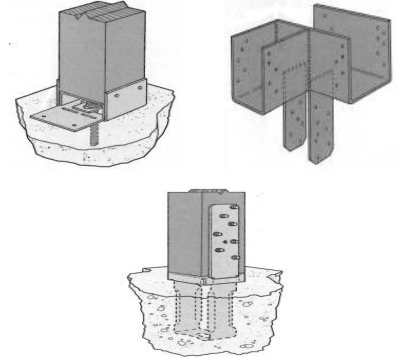

Solid Sawn Lumber Connectors

- LUS/HUS (Joist Hangers)
- LSU/LSSU (Adjustable Light Slopeable U Hanger)
- HU/HUC/HUCQ/HGUS (Glulam Beam & Double Shear Joist Hangers)
- GLS/HGLS/GTL/HGLT (Beam & Glulam Saddle Hangers)
- JB/LB/BA/B/HHB (Joist, Beam & Purlin Hangers)
- Other products like Top Flange Hangers, Skewed Hangers, Pitch Connectors, Hip Ridge Connectors, Truss Hangers, Girder Hangers, Beam/Purlin Hangers, Hinge Connectors, . . .

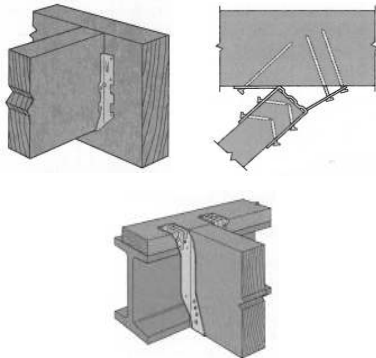

Glulam Beam Connectors

- HU/HUC/HUCQ/HGUS (Glulam beam & Double Shear Hangers)
- LGU/MGU/HGU/HHGU (High Capacity Girder Hangers)
- Also Beams & Purlin Hangers, Saddle Hangers, Hinge Connectors. I-joist hangers, Engineered Wood Products Hangers, Multiple Seat Connections, Hip Ridge Connectors, Slope/Skew Hangers, . . .

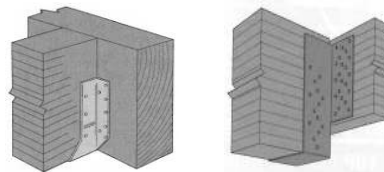

Engineered Wood & Structural Composite Lumber Connectors

- IUS/MIU (I-joist Hangers)
- ITS/MIT/HIT (Enged. Wood Product Hangers)
- LBV/BA/B/HB (I-joist & Structural Composite Lumber Hangers)
- I-joist hangers, Multiple Seat Connections, Hip Ridge Connectors, Slope/Skew Hangers, . . .

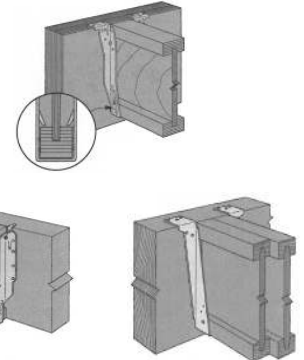

Straps

- MST/MSTC (Strap Ties)
- CS/CMST (Coiled Straps)
- H/TSP (Seismic & Hurricane Ties)
- LTP/A (Framing Angles & Plates)
- Floor Span Connectors, Floor Tie Anchors, Purlin Cross Ties, Seismic & Hurricane Ties

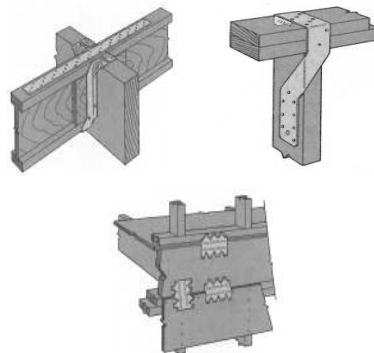

Masonry Connectors

- HGUM/LGUM (High Capacity Beam/Girder Hangers for Concrete/Masonry)
- Ask about other masonry connectors

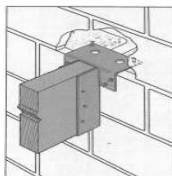

Architectural Products Group

- Ask about specialized products & Finishes



- Call Edge for information or a quote today
- Factory direct distributor of hangers
- Typical finish is galvanized
- We can help with Rapid Response on your special orders--call today

- Edge can provide more detailed specifications & options
- Ask about Plated Truss Connectors
- Ask about Lateral Systems: Moment Frames, Shearwalls, & Anchor Tiedown Systems (ATS)



SIMPSON STRONG-TIE® MASA Mud sill Anchors

- Mudsill anchors have always been a time-saving alternative to anchor bolts
- Two versions of the MASA are available—the standard MASA for installation on standard forms and the MASAP for panelized forms
- Material: 16 gauge
- Finish: Galvanized, all available in ZMAX® coating

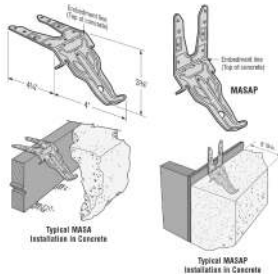

Item #
SNMASA
SNMASAP

SIMPSON STRONG-TIE® SSTB Anchor Bolts

- The SSTB anchor bolt is designed for maximum performance as an anchor bolt for holdowns and Simpson Strong-Tie® Strong-Wall® shearwalls
- The SSTB anchor bolts are now code listed by ICC-ES under the 2006 and 2009 IBC® and IRC® to meet the requirements of ICC-ES acceptance criteria - ACC-399. ICC-ES ESR-2611 is the industry's first code report issued for proprietary anchor bolts evaluated to the criteria of AC 309

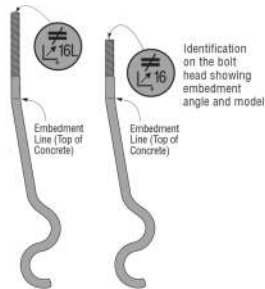

SIMPSON STRONG-TIE® BP Bearing Plates

- Bearing Plates give greater bearing surface than standard cut washers, and help distribute the load at these critical connections
- The BP 1/2 - 3 and BP 5/8 x 3 are 3" x 3" bearing plates that meet the latest requirements of the IRC and IBC; these plate washers are available un-coated or with a HDG coating
- The shear capacity of the connection and the sill/anchor bolt shall be determined by the Designer for each installatio

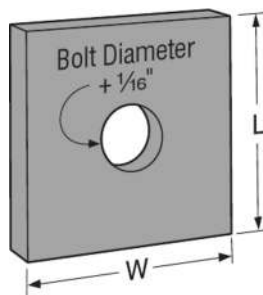

SIMPSON STRONG-TIE® HDU Holdowns

- HDU Holdowns are pre-deflected during the manufacturing process, virtually eliminating deflection under load due to material stretch
- They use Simpson Strong-Tie® Strong-Drive® SDS screws which install easily and provide reduced fastener slip

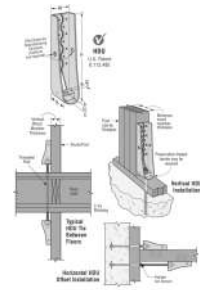

SIMPSON STRONG-TIE® LTT/HTT Tension Ties

- Tension ties offer a solution for resisting tension loads that is fastened by nails
- The entire line of tension ties has been tested and evaluated to the requirements of AC155
- The HTT4 and HTT5 are the latest generation of tension ties. They feature an optimized nailing pattern which results in better performance with less deflection
- Finish: Galvanized. May be ordered in HDG; contact Simpson Strong-Tie

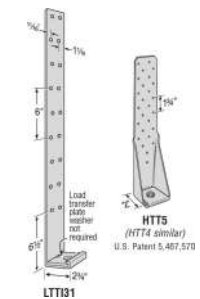

SIMPSON STRONG-TIE® HD Holdowns

Tension Tie

Holdowns are used to transfer tension loads between floors, to tie purlins to masonry or concrete, etc. Use HDAs and HDs for overturning requirements and other applications to transfer tension loads. All HDAs are self-jigging, ensuring code-required minimum 7 bolt diameter spacing from the end of the wood member to the center of the first bolt hole.

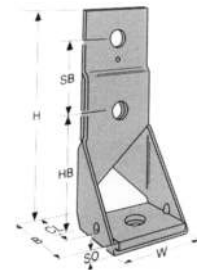

SIMPSON STRONG-TIE® STHD Strap-Tie Holdowns

The STHD is an embedded strap tie holdown with high load capacity and a staggered nail pattern to help minimize splitting.

- The strap nailing pattern allows for nailing to the edges of double 2x's
- A slot below the embedment line allows for increased front to back concrete bond and reduced spalling
- Strap nail slots are countersunk to provide a lower nail head profile
- Rim joist models accommodate up to a 17" clear span without any loss of strap nailing
- Coined edges enhance safe handling

Material: 12 ga.
Codes: ICBO 5349.

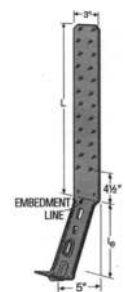



SIMPSON STRONG-TIE®
AB Adjustable and Stand-off Post Bases

The AB is a fully-adjustable post base which offers moisture protection and finished hardware appearance.

Post bases provide tested capacity. They feature 1" standoff height above concrete floors, code-required when supporting permanent structures that are exposed to the weather or water splash, or in basements. They reduce the potential for decay at post and column ends.

Material: 12 ga plates; 16 ga base cover.
Finish: Galvanized.

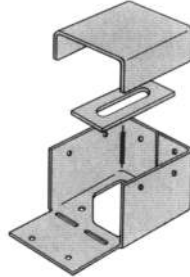

SIMPSON STRONG-TIE®
ABU Adjustable and Standoff Post Bases

- The ABU is an adjustable post base which offers moisture protection and finished hardware appearance
- These post bases feature 1" standoff height above concrete floors, code-required when supporting permanent structures that are exposed to the weather or water splash, or in basements
- They reduce the potential for decay at post and column ends
- Material: 12 gauge plates-16 gauge base cover
- Finish: Galvanized. Some materials available in ZMAX®

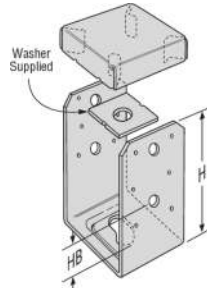

SIMPSON STRONG-TIE®
EPB Elevated Post Bases

Material: 12 ga. base plate, 1 1/16" OD x 8" pipe.

1. Loads may not be increased for short-term loading.
2. EPB46 have extra nail holes; only eight must be filled to achieve table loads.
3. Specifier to design concrete for shear capacity.

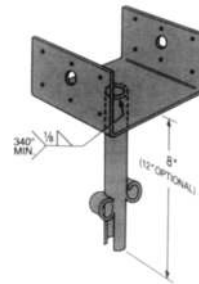

SIMPSON STRONG-TIE®
PB Post Bases

Locking prongs inserts into concrete. The one-piece design assures maximum strength.

Material: 12 gauge.
Codes: BOCA, ICBO, SBCCI NER-443;
City of LA RR 25149.

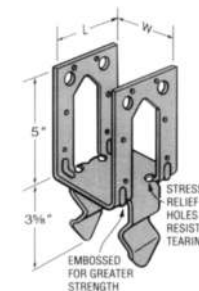

SIMPSON STRONG-TIE®
CBSQ Column Bases

- The CBSQ uses Simpson Strong-Tie® Strong-Drive® SDS screws, which allow for fast installation, reduced reveal and high capacity, provides a greater net section area of the column compared to bolts
- Finish: Galvanized, available in HDG with HDG screws
- Ordering: To order with screws, specify CBSQ-SDS2. To order without screws, specify CBS

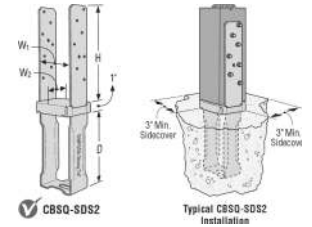

SIMPSON STRONG-TIE®
CB Column Bases

- Finish: CB44, CB46, CB48, CB66, CB68, CB610, CB86- galvanized, all other CB - Simpson Strong-Tie® gray paint or HDG
- Available in rough size. Other sizes available for CB specify W1 and W2 dimensions.

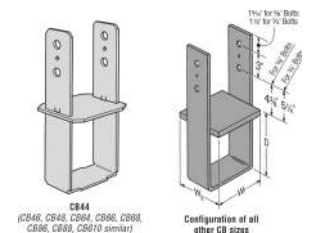

SIMPSON STRONG-TIE®
BC Post Caps

- The BC series offers dual purpose post cap/base for light cap or base connections.
Material: 18 gauge.
Finish: Galvanized.

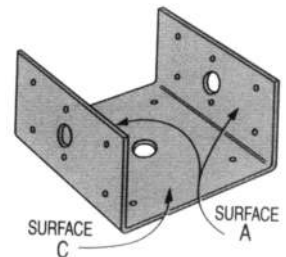

SIMPSON STRONG-TIE®
ECCQ Column Caps

- Column caps provide a high capacity connection for column-beam combinations. This design uses Simpson Strong-Tie® Strong-Drive® SDS screws to provide faster installation and provides a greater net section area of the column compared to bolts. The SDS screws provide for a lower profile compared to standard through bolts
- For rough cut lumber sizes, provide dimensions. An optional W2 dimension may be specified with any column size given. (Note that the W2 dimensions on straps rotated 90° is limited by the W1 dimension)

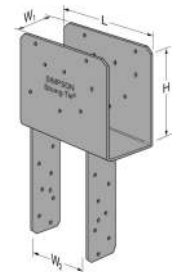

SIMPSON STRONG-TIE®
CC Column Caps

- Column caps provide a high capacity connection for column-beam combinations
- Material: CC3-1/4, CC44, CC46, CC48, CC4.62, CC64, CC66, CC68, CC6-7-1/2 7gauge, all others 3 gauge

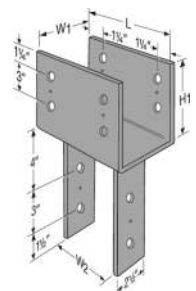



SIMPSON STRONG-TIE® ECC Column Caps

The industry standard column cap. Precision factory gang-punched holes speed installation on this product line. Material: 3 gauge.

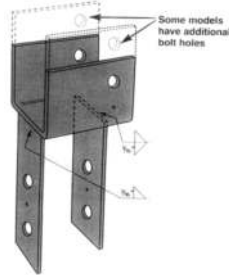

SIMPSON STRONG-TIE® ECCLQ Column Caps

- The ECCLQ column caps provide high capacity, multiple beam to column connection options. The design uses Simpson Strong-Tie® Strong-Drive® screws (SDS) to provide faster installation and a lower profile compared to standard through bolts. Screws are configured to provide high uplift design values
- Material: 7 gauge

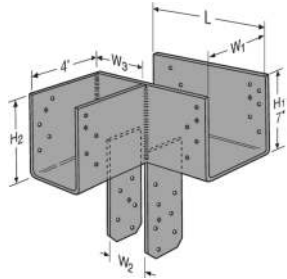

SIMPSON STRONG-TIE® HU Standard Joist Hangers

- Most Models have triangle and round holes
- To achieve maximum loads, fill both round and triangle holes with common nails
- These heavy-duty connectors are designed for schools and other structures requiring additional strength, longevity and safety factors
- Finish: Galvanized. Some products available in ZMAX® coating

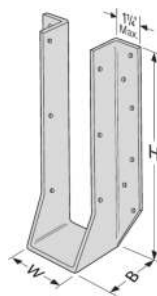

SIMPSON STRONG-TIE® LUS Double Shear Joist Hangers

- All hangers in this series have double shear nailing. This innovation distributes the load through two points on each joist nail for greater strength. It also allows for the use of fewer nails, faster installation, and the use of standard nails for all connections (Do not bend or remove tabs)

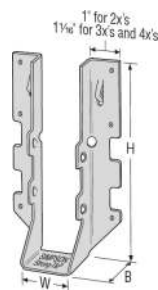

SIMPSON STRONG-TIE® LB Top Flange Hangers

Joist Beam and Purlin Hangers

- Finish: Galvanized, can be ordered in HDG

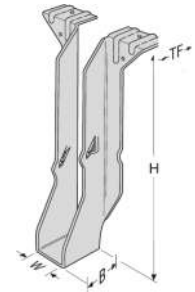

SIMPSON STRONG-TIE® HGLT Top Flange Hangers

- HGLT hangers accommodate typical structural requirements for timber and glulam beams
- Material: All welded GL series glulam hangers have a 3 gauge top flange
- Finish: Simpson Strong-Tie® gray paint. HDG available

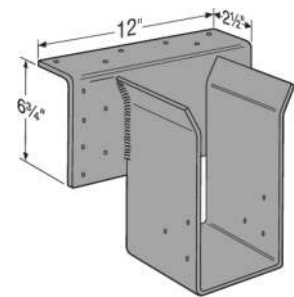

SIMPSON STRONG-TIE® THA Adjustable Truss Hangers

The THA series' extra long straps allow full code nailing and can be field-formed to give top flange hanger convenience.

Codes: BOCA, ICBO, SBCCI NER-209; City of L.A. RR 24949; Dade Co., FL 00-0512.06.

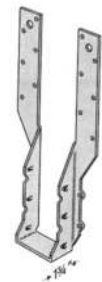

SIMPSON STRONG-TIE® HUCQ Heavy-Duty Joist Hangers

- The HUCQ series are heavy-duty joist hangers that incorporate Simpson Strong-Tie® Strong-Drive® wood screws (SDS)
- Designed and tested for installation at the end of a beam or on a post, they provide a strong connection with fewer fasteners than nailed hangers
- Material: 14 gauge

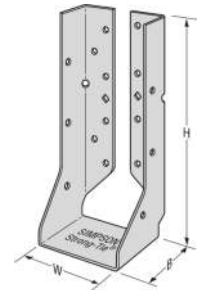

SIMPSON STRONG-TIE® HGUS Glulam Beam and Double Shear Joist Hangers

- Face mount hanger used for high load applications
- All hangers in this series have double shear nailing. This patented innovation distributes the load through two points on each joist nail for greater strength. It also allows for the use of fewer nails, faster installation, and the use of common nails for connections

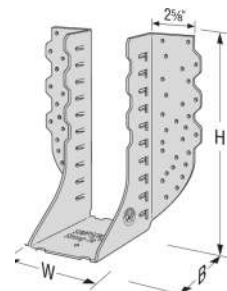



SIMPSON STRONG-TIE®
**HGU High Capacity
Girder Hangers**

- A high capacity girder hanger designed for situations where the header and joist are flush at the top
- These products can be used for retrofit on the framing members after they are temporarily placed in position

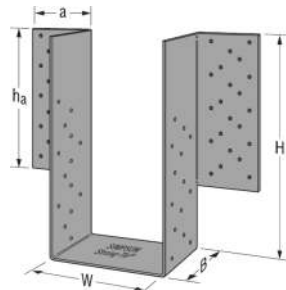

SIMPSON STRONG-TIE®
IUS I-Joist Hangers

- The improved IUS is now fully compatible with shallow flange I-joists
- I-joists with flange thickness between 1-1/8" and 1-1/2" achieve the full allowable loads including uplift values and joist nails are not required
- The IUS is a hybrid hanger that incorporates the advantages of the face mount and top mount hanger

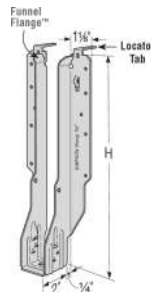

SIMPSON STRONG-TIE®
ITS Top Flange Hangers

Engineered Wood Products Hangers

- The innovative ITS sets a new standard for engineered wood top flange hangers. It installs faster and uses fewer nails than any other EWP top flange hanger
- The new Strong-Grip™ seat and Funnel Flange™ features allow standard joist installation without requiring joist nails resulting in the lowest installed cost
- The Strong-Grip seat firmly secures I-joists with flange thicknesses from 1-1/8" to 1-1/2"

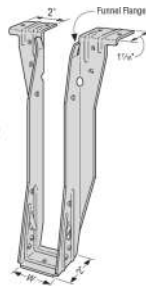

SIMPSON STRONG-TIE®
LBV I Top Flange Hangers

**I-Joist and Structural Composite
Lumber Hanger**

- The newly improved LBV hanger offers wide versatility for I-joists and structural composite lumber
- The LBV features positive angle nailing and does not require the use of web stiffeners for standard non-modified I-joist applications

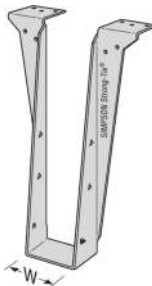

SIMPSON STRONG-TIE®
**LSSU Light Slopeable/
Skewable U Hangers for
I-Joists and SCL**

- Attaches joists or rafters to headers, sloped up or down, and skewed left or right, up to 45°
- 18 Gauge
- Finish: Galvanized

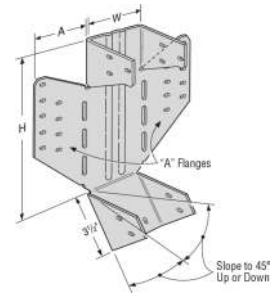

SIMPSON STRONG-TIE®
STC/DTC Roof Truss Clips

For alignment control between a roof truss and nonbearing walls; the 1 1/2" slot permits vertical truss chord movement when loads are applied.

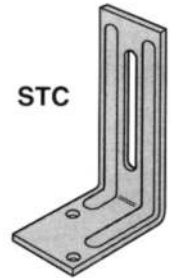

SIMPSON STRONG-TIE®
MST Strap Tie

- Straps are designed to transfer tension loads in a wide variety of applications
- Splitting may be a problem with installations on lumber smaller than 3-1/2"; either fill every nail hole with 10d x 1-1/2" nails or fill every other hole with 16d common nails
- Reduce the allowable load based upon the size and quantity of fasteners used



SIMPSON STRONG-TIE®
TS Twist Straps

Twist straps provide a tension connection between two wood members. An equal number of right and left hand units are supplied in each carton.

Material: 16 gauge.

Some products available in stainless steel and Z-MAX.

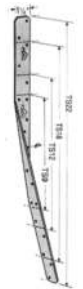

SIMPSON STRONG-TIE®
CS Coiled Straps

- Continuous utility strap which can be cut to length on the job site
- Finish: Galvanized. Some products available in ZMAX® coating

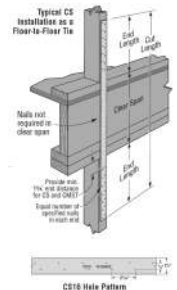



SIMPSON STRONG-TIE® H Seismic and Hurricane Ties

- The Hurricane Tie series features various configurations of wind and seismic ties for trusses and rafters
- Finish: Galvanized. Some items available in stainless steel or ZMAX® coating

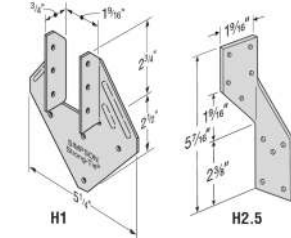

SIMPSON STRONG-TIE® LTP4 Framing Plate

- The LTP4 Lateral Tie Plate transfers shear forces for top plate-to-rim joist or blocking connections
- Nail holes are spaced to prevent wood splitting for single and double top plate applications
- May be installed over plywood sheathing
- Material: 20 gauge

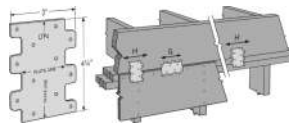

SIMPSON STRONG-TIE® A35 Framing Angle

- The A35 anchor's exclusive bending slot allows instant accurate field bends for all two- and three-way ties
- Balanced, completely reversible design permits the A35 to secure a great variety of connections
- Material: 18 gauge

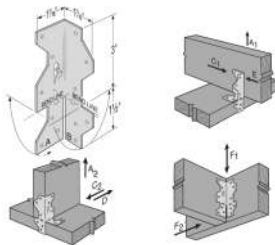

SIMPSON STRONG-TIE® PSCL Panel Sheathing Clips

Material: 20 gauge.
PSCLs per Span: 1

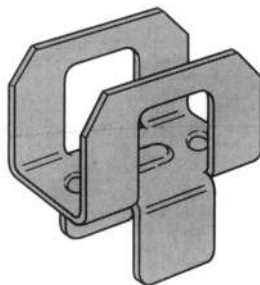

SIMPSON STRONG-TIE® QDPROCCS+M25K Screwdriver Kit Quik Drive®



Includes:

- QDPRO300SG2 attachment
- QDPRO200SG2 attachment
- Extension for stand-up driving
- Quiver for keeping screws at your fingertips
- Tool case
- Expanded depth settings for high-density flooring materials
- Reversible and replaceable non-skid teeth attachment
- Uniform toenailing and countersink on slick surfaces
- Will drive from 1"-3" screws

Item #

QDPROCCS+M25K

SIMPSON STRONG-TIE® #10 Deck/Dock Stainless Screws

Auto-Feed Screw Driving Systems Quik Drive®

- #3 Square drive - BIT3S
- Coarse threads
- Type 17 point
- Bugle head
- Curved collation
- Available in 305 & 316 stainless steel



Item #	Length	Material	Qty
QDSS3DSC3BS	3"	305 SS	1000

SIMPSON STRONG-TIE® #8 Wood-to-Wood Deck Screws

Auto-Feed Screw Driving Systems Quik Drive®

- #3 Undersized square drive - BIT3SU
- Flat head, twin threads
- Nibs under the head for easier countersinking
- Quik Guard® coating, curved collation
- Sharp point style



Item #	Length	Qty
QDWSNTLG212S	2-1/2"	1500
QDWSNTLG3s	3"	1000



SIMPSON STRONG-TIE®
#8 Wood-to-Wood Sub Floor Screws

Auto-Feed Screw Driving Systems
Quik Drive®



- For Subflooring/Sheathing/Wall Plates/Stair Tread
- #3 Square drive - BIT3S
- Flat head, twin threads
- Nibs under the head for easier countersinking
- Yellow zinc dichromate coating, curved collation
- Sharp point style

Item #	Length	Qty
QDWSNTL134S	1-3/4"	2000
QDWSNTL2LS	2"	2000
QDWSNTL212S	2-1/2"	1500

SIMPSON STRONG-TIE®

#3 Square Drive Bit

Auto-Feed Screw Driving Systems



Quik Drive®

- BIT3S - for most screws with #3 recess and interior-grade coating
- BIT3SU - for most screws with #3 recess and exterior-grade coating

Item #	Desc
QDBIT3S-RC10	#3 Square drive bit
QDBIT3SU-RC10	#3 Undersize square drive bit

SIMPSON STRONG-TIE®

Bits and Recess Drives

Quik Drive®

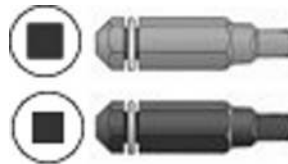

- The bit(s) included in each box of Quik Drive screws should drive the entire box
- Variations in materials and driving technique can cause excessive wear; additional bit packs are available for purchase
- Reference the description on the bit label in your box of screws or the screw box label to ensure correct selection

Item #	Size
QDBIT3S-RC10	#3 Squaredrive
QDBIT3SU-RC10	#3 Undersized



























Edge has a large stock of bolts, anchors, screws, and specialty fasteners.

Call for help with your applications.

Edge is happy to research custom fasteners to meet your requirements.

Your PFERD Abrasives Quick Product Selection Guide: PFERD ADVANCE Power Brushes



① Selection of Filament Material From the workpiece material to the filament material		② Selection of Filament Type From the filament material to the filament style.	③ Selection of Brushes				
			Weld Preparation	Deburring	Cleaning	Surface Texturing	
Workpiece Material ▼	Filament Material ▼	Filament Style ▼	Scale Removal	Cleaning Oxidation / Discolouration	Edge / Surface	Edge / Surface	
Construction steel carbon steel alloy steel non-alloy steel titanium concrete	Carbon steel wire	Crimped wire		 Threaded Crimped Wire Cup Brushes  Crimped Wire Stem Mounted Wheel Brushes	 Threaded Crimped Wire Cup Brushes  Crimped Wire Stem Mounted Wheel Brushes	 Crimped Wire Stem Mounted Wheel Brushes	 Threaded Crimped Wire Cup Brushes
		Knot wire	 Threaded Knot Wire Brushes-Stringer Bead  Threaded Knot Wire Cup Brushes	 Threaded Knot Wire Brushes-Full Cable Twist  Threaded Knot Wire Cup Brushes  Stem Mounted Knot Wire Wheel Brushes	 Threaded Knot Wire Brushes-Full Cable Twist  Threaded Knot Wire Cup Brushes  Stem Mounted Knot Wire Wheel Brushes	 Threaded Knot Wire Brushes-Full Cable Twist  Threaded Knot Wire Cup Brushes	
Stainless steel (INOX) aluminum brass wood plastics copper non-ferrous metals	Stainless steel wire (INOX)	Crimped wire		 Threaded Crimped Wire Cup Brushes			
		Knot wire	 Threaded Knot Wire Brushes-Stringer Bead  Threaded Knot Wire Cup Brushes	 Threaded Knot Wire Brushes-Full Cable Twist  Threaded Knot Wire Cup Brushes	 Threaded Knot Wire Cup Brushes	 Threaded Knot Wire Brushes-Full Cable Twist  Threaded Knot Wire Cup Brushes	 Threaded Knot Wire Brushes-Full Cable Twist  Threaded Knot Wire Cup Brushes



PFERD ADVANCE BRUSH
Brush Adapters

For use with all Pferd Advance small diameter copper center wheel brushes

- Thickness 5/32"



Item #	O.D. (in.)	I.D. (in.)
MB84636	5/8	1/2
MB84639	1/2	3/8
MB84640	1/2	1/4

PFERD ADVANCE BRUSH
Scratch Brushes

- Curved Wood Handle
- Wire rows: 3x19
- Brush length: 6-1/4"
- Block size: 13-3/4"
- Trim length: 1-3/16"



Item #	Filament
MB85002	Carbon Steel Wire
MB85004	Stainless Steel Wire

PFERD ADVANCE BRUSH
Scratch Brush

- Wooden handle
- Wire rows: 3x7
- Brush length: 1-1/2"
- Filament: .006 Stainless Steel Wire
- Block size: 7-1/2" x 1/2"
- Trim length: 1/2"



Item #
MB85055

PFERD ADVANCE BRUSH
Mini Crimped Cup Brush

- Carbon Steel Wire
- Brush diameter: 3-1/2"
- Wire size: .014"
- Thread size: 5/8-11
- Trim length: 7/8"
- Max. RPM: 12,500



Item #
MB82249

PFERD ADVANCE BRUSH
Crimped Wire Cup Brush

- External Thread
- Brush diameter: 6"
- Wire size: .020"
- Wire type: Carbon Steel
- Trim length: 1-3/8"
- Max. RPM: 6,000



Item #
MB82517

PFERD ADVANCE BRUSH
Mini Knot Cup Brush, Standard Twist

- External Thread
- Diameter: 2-3/4"
- Trim length: 7/8"
- Max. RPM: 14,000



Item #	Wire Size (in.)	Filament
MB82220	.020	Carbon Steel
MB82329	.014	Stainless Steel

PFERD ADVANCE BRUSH
Knot Wire Cup Brush, Standard Twist

- Internal Thread
- Thread size: 5/8-11
- Wire type: Carbon Steel
- Diameter: 4"
- Wire Size: .014"
- Max RPM: 7,000
- Trim Length: 1-1/2"



Item #
MB82539

PFERD ADVANCE BRUSH
Crimped Wire Stem Mounted Bevel Brush

- Brush diameter: 2-1/2"
- Wire size: .014"
- Shank diameter: 1/4"
- Wire type: Carbon Steel
- Trim length: 11/16"
- Max. RPM: 20,000



Item #
MB82859



PFERD ADVANCE BRUSH
**Stem Mounted
 Crimped Wire Wheel
 Brush**



- Shank Diameter: 1/4"
- Wire type: Carbon Steel
- Max RPM: 20,000

Item #	Brush Dia. (in.)	Wire Size (in.)	Trim Length (in.)	Face Width (in.)
MB82894	2	.012	1/2	3/8
MB82900	3	.014	1	5/8

PFERD ADVANCE BRUSH
**Stem Mounted Knot
 Wire Wheel Brush,
 Standard Twist**



- Trim Length: 3/4"
- Face Width: 7/16"
- Brush diameter: 3"
- Wire size: .014
- Shank diameter: 1/4"
- Wire type: Carbon Steel
- Max RPM: 25,000

Item #
MB82916

PFERD ADVANCE BRUSH
Knot Wheel Brush

Full Cable Twist



- Brush diameter: 4"
- Wire size: .014"
- Thread size: 5/8-11
- No. Knots: 22
- Trim length: 3/4"
- Max. RPM: 20,000

Item #	Filament
MB82165	Carbon Steel
MB82295	Stainless Steel

PFERD ADVANCE BRUSH
Knot Wheel Brush

Stringer Bead Twist



- Brush diameter: 4"
- Wire size: .020"
- No. Knots: 32
- Trim length: 3/4"
- Face width: 3/16"
- Max. RPM: 20,000

Item #	Thread Size	Filament
MB82186	5/8-11 Thread	Carbon Steel
MB82193	1/2-3/8 Thread	Carbon Steel
MB82307	5/8-11 Thread	Stainless Steel

PFERD ADVANCE BRUSH
Knot Wheel Brush

Stringer Bead Twist



- Carbon Steel Wire
- Brush diameter: 6"
- Wire size: .020"
- Thread size: 5/8-11
- No. Knots: 48
- Trim length: 1-1/8"
- Max. RPM: 12,500

Item #
MB82487

PFERD ABRASIVES
**Tungsten
 Carbide Burs**



**Cylindrical (Plain End)
 Shape A**

- Cylindrical bur with plain end (uncut)
- Application: Deburring
- Shank Dia.: 1/4"

Item #	Head Dia. x Lgth. (in.)	SCTI No.	Overall Length (in.)	Cut Type
PF24065	3/8 x 3/4	SA-3	2 1/2	Alu
PF24033	1/4 x 5/8	SA-1	1 15/16	Diamond
PF24063	3/8 x 3/4	SA-3	2 1/2	Diamond
PF24103	1/2 x 1	SA-5	2 3/4	Diamond
PF24113	5/8 x 1	SA-6	2 3/4	Diamond



Your PFERD Abrasives Quick Product Selection Guide:

PFERD Tungsten Carbide Burs



PFERD-Cuts and Applications

PFERD tungsten carbide burs are designed for machining materials of virtually any strength. The perfect combination of tungsten carbide, shape and cut geometry and, if required, coatings, makes this possible.

PFERD burs are internationally known for highest possible levels of concentricity and consistency. The resulting balance and performance provides many user advantages.



Advantages

- Allows the operator to work more safely.
- Reduces wear on power tool.
- Provides smooth operating action.
- Prevents chatter marks.
- Increases bur service life and stock removal.



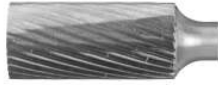
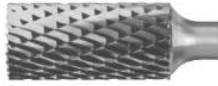

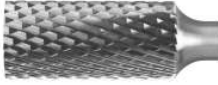



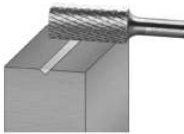

Application Examples

- Deburring.
- Contouring.
- Milling in preparation for build-up welding.
- Weld dressing.
- Milling of acute-angled surfaces.
- Inner contour work, i.e. peripheral and face milling.

Cut Type	Application
Single Cut 	Recommended for high coarse stock removal and good surface finish on cast iron, steel < 60 HRC, stainless steel (INOX), nickel-based alloys and titanium alloys.
Double Cut 	Similar to single cut, but with cross cut. Recommended for high coarse stock removal on cast iron, steel < 60 HRC, stainless steel (INOX), nickel-based alloys and titanium alloys.

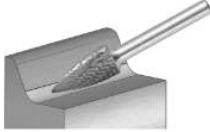
Cut Type	Application
Diamond Cut 	Recommended for machining when a high stock removal is required. Creates short chips and good surface quality on stainless steel (INOX), steel < 60 HRC, high heat-resistant materials such as nickel-based alloys, cobalt-based alloys.
Fine Cut 	Recommended for fine deburring of stainless steel (INOX), high heat-resistant materials such as nickel based, cobalt based alloys.
ALU Cut 	Recommended for coarse machining with high stock removal of aluminum and aluminum alloys, light metals, non-ferrous metals and plastics.

Overview Applications and Shapes

Cylindrical	Cylindrical (End Cut)	Cylindrical (Radius End)	Ball
 Shape A	 Shape B	 Shape C	 Shape D
Oval	Tree (Radius End)	Tree (Pointed End)	
 Shape E	 Shape F	 Shape G	
Flame	Taper	Cone	
 Shape H	 Shape L	 Shape M	



PFERD ABRASIVES
**Tungsten Carbide
Burs**



**Cylindrical (End Cut)
Shape B**

- Application: Interior contour work, i.e., peripheral and face milling
- Shank Dia.: 1/4"
- Box Quantity: 1

Item #	Head Dia. x Lgth. (in.)	SCTI No.	Overall Length (in.)	Cut Type
PF24292	5/8 x 1	SB-6	2 3/4	Double
PF24283	1/2 x 1	SB-5	2 3/4	Diamond
PF24293	5/8 x 1	SB-6	2 3/4	Diamond
PF24343	1 x 1	SB-9	2 3/4	Diamond

PFERD ABRASIVES
**Tungsten Carbide
Burs**



**Cylindrical (Radius End)
Shape C**

- General-use shape (combination of cylindrical and spherical geometries).
- Application: Surface milling, Contouring
- Shank Dia.: 1/4"

Item #	Head Dia. x Lgth. (in.)	SCTI No.	Overall Length (in.)	Cut Type
PF24393	1/4 x 5/8	SC-1	1 15/16	Diamond
PF24423	3/8 x 3/4	SC-3	2 1/2	Diamond
PF24463	1/2 x 1	SC-5	2 3/4	Diamond
PF24473	5/8 x 1	SC-6	2 3/4	Diamond
PF24483	3/4 x 1	SC-7	2 3/4	Diamond
PF24513	1 x 1	SC-9	2 3/4	Diamond

PFERD ABRASIVES
**Tungsten Carbide
Burs**



Ball Shape D

- Application: Contouring, Bore deburring, milling in preparation of build-up welding
- Shank Dia.: 1/4"

Item #	Head Dia. x Lgth. (in.)	SCTI No.	Overall Length (in.)	Cut Type
PF24543	1/4 x 3/16	SD-1	1 15/16	Diamond
PF24563	3/8 x 1 5/16	SD-3	2 1/16	Diamond
PF24593	5/8 x 9/16	SD-6	2 15/16	Diamond

PFERD ABRASIVES
**Tungsten Carbide
Burs**



Oval Shape E

- Application: Contouring
- Shank Dia.: 1/4"

Item #	Head Dia. x Lgth. (in.)	SCTI No.	Overall Length (in.)	Cut Type
PF24633	1/4 x 3/8	SE-1	1 15/16	Diamond
PF24643	3/8 x 5/8	SE-3	2 3/8	Diamond

PFERD ABRASIVES
**Tungsten Carbide
Burs**



**Tree (Radius End)
Shape F**

- Application: Work on narrow contours
- Shank Dia.: 1/4"

Item #	Head Dia. x Lgth. (in.)	SCTI No.	Overall Length (in.)	Cut Type
PF24693	1/4 x 5/8	SF-1	1 15/16	Diamond
PF24703	3/8 x 3/4	SF-3	2 1/2	Diamond
PF24733	1/2 x 3/4	SF-13	2 1/2	Diamond
PF24753	3/4 x 1	SF-7	2 3/4	Diamond

**Ask an Edge sales rep for an
abrasives demo to get the right
product for your specific application.**



PFERD ABRASIVES
Tungsten Carbide Burs

Tree (Pointed End)
Shape G



- Bullet-shaped bur, flattened tip
- Application: Work on narrow contours, Milling of acute-angled surfaces
- Shank Dia.: 1/4"

Item #	Head Dia. x Lgth. (in.)	SCTI No.	Overall Length (in.)	Cut Type
PF24783	1/4 x 5/8	SG-1	1 15/16	Diamond
PF24793	15/16 x 3/4	SG-2	2 1/2	Diamond
PF24803	3/8 x 3/4	SG-3	2 1/2	Diamond
PF24813	1/2 x 1	SG-5	2 3/4	Diamond

PFERD ABRASIVES
Tungsten Carbide Burs

Flame
Shape H



- Application: Contouring
- Shank Dia.: 1/4"

Item #	Head Dia. x Lgth. (in.)	SCTI No.	Overall Length (in.)	Cut Type
PF24863	1/4 x 5/8	SH-1	1 15/16	Diamond

PFERD ABRASIVES
Tungsten Carbide Burs

14° Taper (Radius End)
Shape L



- Application: Work on narrow contours and surfaces, surface machining
- Shank Dia.: 1/4"

Item #	Head Dia. x Lgth. (in.)	SCTI No.	Overall Length (in.)	Cut Type
PF25143	5/16 x 1	SL-2	2 13/16"	Diamond
PF25153	3/8 x 1 1/8	SL-3	3"	Diamond
PF25163	1/2 x 1 1/8	SL-4	3 1/16"	Diamond

PFERD ABRASIVES
Tungsten Carbide Burs

Cone (Pointed End)
Shape M



- Conical bur, flattened tip
- Application: Work on narrow contours, Surface machining
- Shank Dia.: 1/4"

Item #	Head Dia. x Lgth. (in.)	Angle (deg.)	SCTI No.	Overall Length (in.)	Cut Type
PF25222	1/4 x 1	10	SM-3	1 15/16	Double Diamond
PF25213	1/4 x 3/4	14	SM-2	1 15/16	Diamond
PF25253	5/8 x 1 1/8	31	SM-6	2 15/16	Diamond

PFERD ABRASIVES
Bench Wheel Bushings

- Provide a safe method of reducing the wheel arbor to accommodate various spindle sizes
- The bushing should be flush on both sides of the wheel, and should not interfere with the flanges



Item #	Dia. (in.)
PF69012	1/4 to 1
PF69017	1/4 to 1/2

PFERD ABRASIVES
Reducer Bushings

Item #	Diameter
PF69003	1" to 7/8"
PF69004	1" to 20 mm



**Ask for a
full-line Pferd
catalog to see
all products
available!**



Your PFERD Abrasives Quick Product Selection Guide Grinding and Cut-Off Wheels

Starting with your work application ① and material ②, the chart below shows the various types of PFERD abrasives available for your specific job.

① Application \ ② Workpiece Material	Steel, Cast Steel	Stainless Steel (INOX)	Aluminum, Non-Ferrous Metals	Scale, Cast Iron	Cast Iron, Stone, Masonry
REINFORCED GRINDING WHEELS					
Surface Grinding	PS-FORTE Hardness L SG-ELASTIC Hardness R	PS-FORTE Hardness L SG-ELASTIC Hardness N (INOX)	SG-ELASTIC-Alu Hardness N	SG-ELASTIC Hardness S (ZA)	SG-ELASTIC Hardness Q
Weld Grinding	PS-FORTE Hardness L SG-ELASTIC Hardness R	PS-FORTE Hardness L SG-ELASTIC Hardness N (INOX)	SG-ELASTIC-Alu Hardness N	SG-ELASTIC Hardness S (ZA)	-
Chamfering	PS-FORTE Hardness L SG-ELASTIC Hardness R	PS-FORTE Hardness L SG-ELASTIC Hardness N (INOX)	-	SG-ELASTIC Hardness S (ZA)	SG-ELASTIC Hardness Q
Deburring	PS-FORTE Hardness L SG-ELASTIC Hardness R	SG-ELASTIC Hardness N (INOX)	-	SG-ELASTIC Hardness S (ZA)	SG-ELASTIC Hardness Q
Fillet Grinding	PS-FORTE Hardness L SG-ELASTIC Hardness R	PS-FORTE Hardness L SG-ELASTIC Hardness N (INOX)	SG-ELASTIC-Alu Hardness N	-	-
Root Pass (Pipeline)	PS-FORTE Hardness P SG-ELASTIC Hardness R Hardness S (ZA)	PS-FORTE Hardness M (INOX) SG-ELASTIC Hardness N (INOX)	-	-	-
CUT-OFF WHEELS					
Cutting of Sheet Metal and Thin-Walled Profiles < 1/3"	PS-FORTE Hardness P SG-ELASTIC Hardness S	SG-ELASTIC Hardness R (INOX) SG-PLUS Hardness S (INOX)	SG-ELASTIC Hardness R (C)	-	SG-ELASTIC Hardness R (C)
Cutting Solid Material and Profiles	PS-FORTE Hardness P SG-ELASTIC Hardness S	SG-ELASTIC Hardness R (INOX) SG-PLUS Hardness S (INOX)	SG-ELASTIC Hardness R (C)	SG-ELASTIC Hardness Q	SG-ELASTIC Hardness R (C) Hardness Q
POLIFAN® FLAP DISCS	Steel, Cast Steel	Stainless Steel (INOX)	Aluminum, Non-Ferrous Metals	Plastics and other Materials	Stone, Masonry
Surface Grinding	POLIFAN® PSF A POLIFAN® PSF ZIRKON POLIFAN® SG A POLIFAN® SG ZIRKON	POLIFAN® PSF A POLIFAN® PSF ZIRKON POLIFAN® SG A POLIFAN® SG A-COOL	POLIFAN® SG A-COOL	POLIFAN® PSF A POLIFAN® SG A POLIFAN® SG A-COOL	POLIFAN® SG SIC
Weld Grinding	POLIFAN® PSF A POLIFAN® PSF ZIRKON POLIFAN® SG A POLIFAN® SG ZIRKON POLIFAN® SGP ZIRKON-STRONG	POLIFAN® PSF ZIRKON POLIFAN® SG ZIRKON	POLIFAN® SG A-COOL POLIFAN® SG SIC	-	-
Chamfering	POLIFAN® SG ZIRKON POLIFAN® SGP ZIRKON-STRONG	POLIFAN® SG ZIRKON	POLIFAN® SG SIC	POLIFAN® PSF A POLIFAN® SG A	POLIFAN® SG SIC
Deburring	SGP ZIRKON-STRONG	POLIFAN® SG ZIRKON	POLIFAN® SG SIC	POLIFAN® PSF A POLIFAN® SG A	-
Fillet Grinding	POLIFAN® SGP ZIRKON-CURVE	POLIFAN® SGP ZIRKON-CURVE	-	-	-

Product Lines

For the wide variety of abrasive grinding applications in industry and trade PFERD now offers three lines of abrasives:

Universal Line PS-FORTE (PSF)

General use in industry and professional trades.

Performance Line SG-ELASTIC (SG)

Widest range of tools for professional use in industry and professional trades.

Special Line SG-PLUS (SGP)

For highest possible performance, and for industrial niche applications.



Your PFERD Abrasives Quick Product Selection Guide: Coated and Non-Woven Abrasives



Type of Operation		Face-Down Grinding Tools for Use with Backing Pad	Peripheral Grinding Mounted/Unmounted Tools	Manual Grinding
Processing Step				
Rough Gringing Fine Surface Finishing 	Modification of workpiece geometry	 Fibre Discs Aluminum oxide grain Grit Sizes: 16, 24, 36		
	Multi-step fine grinding, reducing roughness	 Fibre Discs Aluminum oxide grain Grit Sizes: 50, 60, 80	 Mounted Flap Wheels for Angle Grinders Aluminum oxide grain Grit Sizes: 60, 80, 120 or Zirconia alumina grain Grit Sizes: 60, 80	
	Fine grinding Ultra fine grinding	 Fibre Discs Aluminum oxide grain Grit Sizes: 80, 100, 120	 Mounted Flap Wheels for Angle Grinders Aluminum oxide grain Grit Sizes: 120, 180, 240 or Zirconia alumina grain Grit Sizes: 120	
	Cleaning	 POLIVLIES™ Hook and Loop Discs Grit Sizes: Coarse, Medium		 POLIVLIES™ Hand Pads Abrasive: Aluminum oxide A General purpose, Medium finish
	Creation of visual surface effects	 POLIVLIES™ Hook and Loop Discs Grit Size: Very Fine		 POLIVLIES™ Hand Pads Abrasive: Silicon carbide SiC Ultra fine finish



PFERD ABRASIVES

Coated Abrasive Fiber Discs

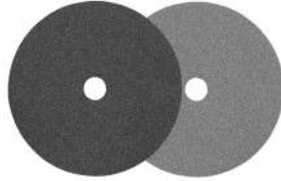

- Well suited for both rough and fine grinding
- Very flexible
- For flat and irregular surfaces
- Long life resin bond

Item #	Diameter x Arbor	Grain	Grit	Max. RPM
PF62402	4 x 5/8	Aluminum Oxide	24	15,900
PF62403	4 x 5/8	Aluminum Oxide	36	15,900
PF62406	4 x 5/8	Aluminum Oxide	80	15,900
PF62451	4 1/2 x 7/8	Aluminum Oxide	16	13,300
PF62452	4 1/2 x 7/8	Aluminum Oxide	24	13,300
PF62453	4 1/2 x 7/8	Aluminum Oxide	36	13,300
PF62454	4 1/2 x 7/8	Aluminum Oxide	50	13,300
PF62455	4 1/2 x 7/8	Aluminum Oxide	60	13,300
PF62456	4 1/2 x 7/8	Aluminum Oxide	80	13,300
PF62457	4 1/2 x 7/8	Aluminum Oxide	100	13,300
PF62701	7 x 7/8	Aluminum Oxide	16	8,500
PF62702	7 x 7/8	Aluminum Oxide	24	8,500
PF62703	7 x 7/8	Aluminum Oxide	36	8,500
PF62704	7 x 7/8	Aluminum Oxide	50	8,500
PF62705	7 x 7/8	Aluminum Oxide	60	8,500
PF62706	7 x 7/8	Aluminum Oxide	80	8,500
PF62708	7 x 7/8	Aluminum Oxide	120	8,500

PFERD ABRASIVES

Mounted Flap Wheels

Zirconia Alumina



- Designed for use on stainless steel and high temperature alloys
- Provide high stock removal rates and particularly cool grinding action (abrasive will not load up)
- Length: 1"; Shank Dia.: 1/4"

Item #	Dia. (in.)	Grit	Recom. Speed RPM	Max. RPM
PF45473	2	60	7,000	23,000
PF45481	3	60	4,800	20,000
PF45466	1	80	15,000	25,000
PF45474	2	80	7,000	23,000
PF45467	1	120	15,000	25,000
PF45483	3	120	4,800	20,000

PFERD ABRASIVES

Mounted Flap Wheels

Aluminum Oxide



- 1/4" Shaft Size
- Adapt readily to irregular surfaces
- Can be used in flat surfaces and in difficult to reach areas
- Can be profiled to contours of the workpiece

Item #	Diameter (in.)	Length (in.)	Grit	Rec. RPM	Max RPM
PF45185	1	80	15,000	25,000	
PF45233	1-1/2"	1	80	9,600	23,000
PF45238	2	1	60	7,000	23,000
PF45239	2	1	80	7,000	23,000
PF45240	2	1	120	7,000	23,000
PF45241	2	1	180	7,000	23,000
PF45242	2	1	240	7,000	23,000
PF45208	3	1	60	4,800	20,000
PF45209	3	1	80	4,800	20,000

PFERD ABRASIVES

POLIFAN® Flap Discs

Aluminum Oxide

- Workpiece Materials: Metals, plastics, wood
- Application: Surface grinding, edge grinding



Item #	Dia. (in.)	Thickness Nominal (in.)	Grit	Max. RPM
--------	------------	-------------------------	------	----------

Flat (PFF-Type 27) - 7/8" Unthreaded Arbor Hole

PF62009	4 1/2	5/8	40	13,300
PF62010	4 1/2	5/8	60	13,300
PF62011	4 1/2	5/8	80	13,300
PF62012	4 1/2	1/2	120	13,300

Flat (PFF-Type 27) - 5/8"-11 Threaded Arbor Hole

PF62028	4 1/2	5/8	40	13,300
PF62029	4 1/2	5/8	60	13,300
PF62030	4 1/2	5/8	80	13,300
PF62031	4 1/2	1/2	120	13,300



PFERD ABRASIVES
POLIFAN® Flap Discs

Zirconia Alumina

- INOX-Rated: Free of iron, sulphur and chlorinated fillers; suitable for use on stainless steel
- Workpiece Materials: Steel, stainless steel (INOX)
- Application: Weld dressing, edge finishing



Item #	Dia. (in.)	Thickness Nominal (in.)	Grit	Max. RPM
--------	------------	-------------------------	------	----------

Flat (PFF-Type 27) - 7/8" Unthreaded Arbor Hole

PF62014	4 1/2	5/8	40	13,300
PF62015	4 1/2	9/16	60	13,300

Flat (PFF-Type 27) - 5/8"-11 Threaded Arbor Hole

PF62034	4 1/2	9/16	60	13,300
PF62033	4 1/2	5/8	40	13,300

Conical (PFC-Type 29) - Unthreaded Arbor Hole

PF62052	4 1/2	5/8	40	13,300
---------	-------	-----	----	--------

PFERD ABRASIVES
POLIFAN® Flap Discs

Aluminum Oxide plus Coolant SG-ELASTIC

- Unique flap disc with particularly cool grinding features on materials with poor thermal conductivity
- Excels at grinding applications which require high-grade surface finish and low thermal stress
- Workpiece Materials: Stainless steel (INOX), aluminum, non-ferrous metals
- Application: Weld dressing, surface grinding with low heat input



Item #	Dia. (in.)	Thickness Nominal (in.)	Grit	Bore (in.)	Max. RPM
--------	------------	-------------------------	------	------------	----------

Flat (PFF-Type 27) - Unthreaded Arbor Hole

PF62361	4 1/2	3/4	40	7/8	13,300
PF62362	4 1/2	5/8	60	7/8	13,300
PF62363	4 1/2	5/8	80	7/8	13,300

Flat (PFF-Type 27) - 5/8"-11 Threaded Arbor Hole

PF62383	7	5/8	80	-	8,600
---------	---	-----	----	---	-------

PFERD ABRASIVES
POLIFAN® Flap Discs

Aluminum Oxide SG-ELASTIC

- Workpiece Materials: Metals, plastics, wood
- Application: Surface grinding, edge grinding



Item #	Dia. (in.)	Thickness Nominal (in.)	Grit	Bore (in.)	Max. RPM
--------	------------	-------------------------	------	------------	----------

Flat (PFF-Type 27) - Unthreaded Arbor Hole

PF62140	4	5/8	40	5/8	15,300
PF62142	4	5/8	60	5/8	15,300
PF62144	4	9/16	80	5/8	15,300
PF62146	4	1/2	120	5/8	15,300
PF62150	4 1/2	3/4	40	7/8	13,300
PF62152	4 1/2	5/8	60	7/8	13,300
PF62154	4 1/2	5/8	80	7/8	13,300
PF62156	4 1/2	5/8	120	7/8	13,300
PF62160	5	5/8	60	7/8	12,200
PF62168	7	3/4	40	7/8	8,600
PF62172	7	5/8	80	7/8	8,600
PF62174	7	5/8	120	7/8	8,600

Flat (PFF-Type 27) - 5/8"-11 Threaded Arbor Hole

PF62250	4 1/2	3/4	40	-	13,300
PF62252	4 1/2	5/8	60	-	13,300
PF62254	4 1/2	5/8	80	-	13,300
PF62266	7	3/4	24	-	8,600
PF62268	7	3/4	40	-	8,600
PF62270	7	5/8	60	-	8,600
PF62272	7	5/8	80	-	8,600
PF62274	7	5/8	120	-	8,600

Conical (PFC-Type 29) - Unthreaded Arbor Hole

PF62202	4 1/2	5/8	40	7/8	13,300
PF62207	7	3/4	24	7/8	8,600
PF62208	7	5/8	40	7/8	8,600
PF62209	7	5/8	60	7/8	8,600
PF62210	7	5/8	80	7/8	8,600



PFERD ABRASIVES
POLIFAN® Flap Discs

Zirconia Alumina SG-ELASTIC

- High stock removal rate and extended service life.
- INOX-Rated: Free of iron, sulphur and chlorinated fillers; suitable for use on stainless steel
- Workpiece Materials: Steel, stainless steel (INOX)
- Application: Weld dressing, edge finishing



Item #	Dia. (in.)	Thickness Nominal (in.)	Grit	Bore (in.)	Max. RPM
--------	------------	-------------------------	------	------------	----------

Flat (PFF-Type 27) - Unthreaded Arbor Hole

PF62176	4½	¾	40	7/8	13,300
PF62178	4½	¾	60	7/8	13,300

Flat (PFF-Type 27) - 5/8"-11 Threaded Arbor Hole

PF62276	4½	¾	40	-	13,300
PF62278	4½	¾	60	-	13,300
PF62288	7	13/16	40	-	8,600
PF62290	7	¾	60	-	8,600

Conical (PFC-Type 29) - Unthreaded Arbor Hole

PF62222	4½	5/8	40	7/8	13,300
PF62228	7	13/16	40	7/8	8,600
PF62229	7	5/8	60	7/8	8,600

PFERD ABRASIVES

Hook and Loop Disc Holders

POLIVLIES™

- Permits surface finishing without visible transitions
- Rapid tool changes



Item #	Dia. (in.)	Shank Dia./Thread	Max. RPM
PF43410	4½	5/8"-11	10,000
PF43412	5	5/8"-11	10,000

PFERD ABRASIVES

POLIFAN® Flap Discs

Silicon CarbideSG-ELASTIC

- Professional tool for grinding on hard to machine metals, plastics and masonry products.
- Workpiece Materials: Titanium, aluminum, fiberglass, plastics, masonry
- Application: Surface grinding, edge grinding



Item #	Type	Desc. (in.)	Thickness Nominal (in.)	Grit	Max. RPM
--------	------	-------------	-------------------------	------	----------

Flat (PFF-Type 27)- 7/8" Unthreaded Arbor Hole

PF62124	Unthreaded Arbor Hole	4½	¾	24	13,300
PF62125	Unthreaded Arbor Hole	4½	¾	40	13,300
PF62126	Unthreaded Arbor Hole	4½	5/8	80	13,300

PFERD ABRASIVES

POLIFAN® Flap Discs

POLIFAN®-STRONG

- Fastest possible stock removal rates
- Extended flap length allows for aggressive grinding
- Extremely long tool life
- Abrasive: Zirconia alumina Z
- Workpiece Materials: Steel
- Application: Work on weld seams, chamfering, deburring



Item #	Diameter (in.)	Thickness (in.)	Grit	Bore (in.)	Max (RPM)
--------	----------------	-----------------	------	------------	-----------

Conical (PFC - Type 29)

PF62945	4½	9/16	36	7/8	13,300
PF62947	4½	1/2	50	7/8	13,300
PF62955	5	9/16	36	7/8	12,200

**POLIFAN - STRONG
=
FAST STOCK REMOVAL**



PFERD ABRASIVES
POLIFAN® Flap Discs
POLIFAN®-CURVE



- Multipurpose - may be used in conventional and underhand applications
- Achieves smooth, consistent surface finish on fillet welds
- Abrasive: Zirconia alumina Z (40 grit)
- Workpiece Materials: Steel, stainless steel (INOX)
- Application: Fillet weld grinding, chamfering, deburring

Item #	Diameter (in.)	Fillet Weld Width (in.)	Arbor Hole	Max (RPM)
--------	----------------	-------------------------	------------	-----------

Radial Shape (PFR)

PF67339	4½	Large > 5/16	7/8	12,200
PF67359	4½	Large > 5/16	5/8-11	12,200
PF67343	5	Large > 5/16	7/8	12,200
PF67363	5	Large > 5/16	5/8-11	12,200



PFERD ABRASIVES
Hook and Loop Discs
POLIVLIES™



- Attach to the holder by a series of hooks and loops that permits easy-on, easy-off disc changes
- Strong non-woven material will make quick work of heavy oxidation removal, cleaning, and conditioning

Item #	Dia. (in.)	Grade	Recom. Speed RPM	Max. RPM
PF43446	4½	Coarse	3,000	5,000
PF43450	5	Coarse	2,600	5,000
PF43458	7	Coarse	1,800	3,000
PF43447	4½	Medium	3,000	5,000
PF43449	4½	Very Fine	3,000	5,000
PF43453	5	Very Fine	2,600	5,000

PFERD ABRASIVES
Hand Pads
POLIVLIES™

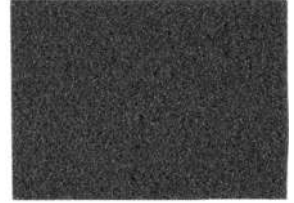

- Designed for light manual grinding, deburring and cleaning work on metals, plastics, glass-fiber reinforced plastics, stainless steel, aluminum, paint, coatings and fillers
- Due to their flexibility, pads provide outstanding results on contours and in hard-to-reach workpiece areas
- Suitable for dry or wet use
- Width x Length: 6"x9"

Item #	Desc.	Grain	Color
PF44600	General Purpose	Aluminum Oxide	Maroon
PF44606	Medium Finish	Aluminum Oxide	Tan
PF44609	Ultra Fine	Silicon Carbide	Grey

PFERD ABRASIVES
Bench Wheels
Universal Line PS-FORTE
Flat (Type 1)



- Designed for use on bench and pedestal grinders, these vitrified wheels offer high performance on a multitude of applications
- Packaged with telescoping bushings to accommodate popular machine spindle sizes
- Abrasive: Aluminum Oxide
- Workpiece Materials: Steel and all ferrous metals
- Also used for sharpening edges of tools made of high speed steel

Item #	Thickness Nominal (in.)	Bore (in.)	Grit	Max. RPM
--------	-------------------------	------------	------	----------

8" Diameter

PF61766	1	1¼	60	3,600
PF61767	1	1¼	80	3,600

10" Diameter

PF61771	1	1¼	60	2,485
PF61772	1	1¼	80	2,485

PFERD ABRASIVES
Cup Wheels
Type 11 Flared



- Aluminum Oxide Mineral, 16 Grit
- High concentration of abrasive grain
- For use on steel, cast iron
- Aggressive cutting action
- Steel back
- 5/8-11 Threaded Arbor Hole

Item #	Diameter (in.)	Thickness (in.)	Max RPM
--------	----------------	-----------------	---------

PF61801	4 x 3½	1	8,600
PF61802	5 x 3¾	1½	7,600
PF61803	6 x 4¾	1½	6,300



PFERD ABRASIVES Cup Wheels

Type 11 - Flared

- Abrasive: Silicon Carbide
- Workpiece Materials: Natural and synthetic masonry
- Application: Wet grinding, dry grinding
- Steel Back
- 5/8-11 Threaded Arbor Hole



Item #	Dia. (in.)	Thickness Nominal (in.)	Max RPM
PF61805	4 x 3½	1	8,600
PF61806	5 x 3¾	1½	7,600
PF61807	6 x 4¾	1½	6,300

PFERD ABRASIVES Cut-Off Wheel

Depressed Center Type 27

- High performance cutting of stainless steel
- Abrasive: A- Aluminum Oxide - Inox rated
- Bond: SG- Fast cutting action and long service life



Item #	Diameter (in.)	Thickness (in.)	Arbor (in.)	Max RPM
PF63202	4½	¾	7/8	13,300
PF63204	4½	1/8	7/8	13,300

PFERD ABRASIVES Cut-Off Wheels

Flat - Type 1

- Long service life
- Fast cutting action
- For use on steel
- 5/8, Diamond punch-out Arbor
- For use on circular saws, air and electric grinders
- 1/8" Thick



Item #	Desc.	Diameter (in.)	Max RPM
PF63842	Steel	7	8,600
PF63843	Steel	8	7,600
PF63845	Masonry	7	8,600

PFERD ABRASIVES

Cut-Off Wheels

Depressed Center Type 27

- A-SG Premium line of Type 27 cut-off wheels
- Long service life
- Fast cutting action
- For use on Steel, cast iron
- For use on air and electric grinders
- 63202- for Stainless Steel



Item #	Diameter (in.)	Thickness	Arbor	Max RPM
PF63101	4	1/8	3/8	15,300
PF63102	4	3/32	5/8	15,300
PF63103	4½	3/32	7/8	13,300
PF63114	4½	3/32	5/8-11 Threaded	13,300
PF63104	4½	1/8	7/8	13,300
PF63115	4½	1/8	5/8-11 Threaded	13,300
PF63106	5	1/8	7/8	12,200
PF63119	6	1/8	5/8-11 Thread	10,200
PF63112	7	1/8	5/8-11 Thread	8,600
PF63111	9	1/8	5/8-11 Thread	6,600
PF63119	6	1/8	7/8	10,200

PFERD ABRASIVES

Portable Saw Cut-Off Wheels

- Heavily reinforced for safety
- Fast cutting action
- Long service life
- 1/8" Thick



Item #	Diameter (in.)	Arbor	Max RPM	Mineral, Bond
--------	----------------	-------	---------	---------------

For Cutting Steel

PF64012	12	20mm	5,100	Aluminum Oxide
PF64014	12	1	5,100	Aluminum Oxide
PF64018	14	1	5,500	Aluminum Oxide

For Cutting Cast Iron/Steel Reinforced Concrete

PF64121	12	20mm	5,100	Silicon Carbide / Aluminum Oxide Blend
PF64122	12	1	5,100	Silicon Carbide / Aluminum Oxide Blend
PF64123	14	20mm	5,500	Silicon Carbide / Aluminum Oxide Blend
PF64124	14	1	5,500	Silicon Carbide / Aluminum Oxide Blend

For Masonry

PF64232	12	20mm	5,100	Silicon Carbide
PF64234	12	1	5,100	Silicon Carbide
PF64236	14	20mm	5,500	Silicon Carbide
PF64238	14	1	5,500	Silicon Carbide



PFERD ABRASIVES
**Electric Chop Saw
Cut-Off Wheels**

- Aluminum Oxide abrasive
- Suitable for use on low powered electric chop saws
- For use on Steel
- Fast cutting action
- For general purpose use
- 1" Arbor Hole



Item #	Diameter (in.)	Thickness (in.)	Max RPM
PF64501	12	3/32	5,100
PF64502	14	3/32	4,400

PFERD ABRASIVES
**Stationary Saw
Cut-Off Wheels**

Aluminum Oxide

- High performance cut-off wheels for stationary saws
- Fully reinforced



Item #	Diameter (in.)	Thickness	Arbor	Max RPM
PF66004	16	1/8	1	3,800
PF66006	20	3/16	1 1/4	3,100
PF66005	20	1/8	1	3,100
PF66009	10	1/8	5/8	7,600
PF66019	20	3/16	1	3,800

PFERD ABRASIVES
Cut-Off Wheels

Depressed Center - Type 27

- Superior thin cut-off wheel for maximum performance
- Smooth, cool, fast cutting action
- Abrasive: Aluminum Oxide
- Workpiece Materials: Stainless Steel (INOX). Also suitable for carbon steel and all ferrous metals
- Application: Cutting of sheet metal, sections, and solid material
- Arbor: 7/8"



Item #	Dia. (in.)	Thickness Nominal (in.)	Max. RPM
PF63172	4 1/2	.045	13,300
PF63174	6	.045	10,200

PFERD ABRASIVES
Thin Cut-Off Wheels

Flat-Type 1

- Aluminum Oxide abrasive
- For General Purpose cut-off use
- For use on Steel
- Fast cutting action



Item #	Diameter (in.)	Thickness (in.)	Arbor	Max RPM	Grit
PF69203	2	.035	3/8	30,000	60
PF69259	2	1/16	1/4	27,000	36
PF69303	3	.035	3/8	25,000	60
PF69305	3	1/16	1/4	25,000	36
PF69309	3	1/16	3/8	25,000	36
PF69317	3	1/8	3/8	25,000	36
PF69403	4	.035	3/8	19,000	60
PF69405	4	1/16	1/4	19,000	36
PF69409	4	1/16	3/8	19,000	36
PF69420	4	1/8	3/8	19,000	24
PF69603	6	.035	5/8	10,200	60
PF69606	6	1/16	5/8	10,200	36
PF69945	4 1/2	.040	7/8	13,300	60
PF69960	6	.040	7/8	10,200	60

PFERD ABRASIVES
Cut-Off Wheels

Depressed Center - Type 27

- Abrasive: Aluminum Oxide
- Workpiece Materials: Steel, cast iron
- Application: Cutting of sheet metal, sections, and solid material
- Thickness Nominal: .045" (1.6 mm)
- Arbor: 7/8"



Item #	Dia. (in.)	Max. RPM
PF63162	4 1/2	13,300
PF63163	5	12,200
PF63164	6	10,200



PFERD ABRASIVES

Depressed Center Cut-Off Wheels

Depressed Center - Type 27

- Abrasive: Silicon Carbide
- Workpiece Materials: Natural stone, synthetic stone, refractory brick
- Application: For cutting solid material
- Recommendation for Use: Use 3/32" gauge cut-off wheels for maximum tool life and high lateral stability



Item #	Dia. (in.)	Thickness Nominal (in.)	Thread	Max. RPM
PF63309	4½	⅜	⅝"-11	13,300

PFERD ABRASIVES

Die Grinder Cut-Off Wheels

Flat - Type 1 - SG-Plus

- Superior thin cut-off wheel for maximum performance
- Smooth, cool, fast cutting action
- Abrasive: Aluminum Oxide
- Workpiece Materials: **STAINLESS STEEL (INOX)**, also suitable for carbon steel and all ferrous metals
- Application: Cutting of sheet metal, sections, and solid material



Item #	Dia. (in.)	Thickness Nominal (in.)	Bore (in.)	Grit	Max. RPM
PF69832	3	.040	¼	60	25,000
PF69834	3	⅛	⅜	46	25,000
PF69842	4	.040	⅝	60	15,200
PF69862	6	.040	⅞	60	10,200
PF69846	4½	.045	⅞	46	13,300
PF69865	6	.045	⅞	46	10,200

PFERD ABRASIVES

Street Saw Cut-Off Wheels

- Specially designed for use on walk-behind saws with drive pin
- Used for cutting expansion joints, new road construction and repair
- Abrasive: Silicon Carbide
- Workpiece Materials: Concrete, Cured Concrete
- Application: Cutting expansion joints
- Pin Hole: 3/8"
- Bore: 1"



Item #	Dia. (in.)	Thickness Nominal (in.)	Max. RPM
PF64304	14	⅜	5,500

PFERD ABRASIVES

Stud Cut-Off Wheels

- Special tool with extended lateral stability for abrasive cutting operations using stationary chopsaws
- Abrasive: Aluminum Oxide
- Workpiece Materials: Steel
- Application: Cuts metal studs, thin rebar, sheet stock and light gauge metal
- Bore: 1"



Item #	Dia. (in.)	Thickness Nominal (in.)	Max. RPM
PF64505	14	⅛"	4,400

PFERD ABRASIVES

General Purpose Grinding Wheels

Type 27 Depressed Center

- Aluminum Oxide abrasive
- General purpose grinding wheel for steel and stainless steel (INOX)
- Fast stock removal
- 1/4" Thick



Item #	Diameter (in.)	Arbor	Max RPM
PF61000	4	⅝	15,300
PF61002	4½	⅞	13,300
PF61001	4½	⅝-11 Thread	13,300
PF61003	5	⅞	12,200
PF61008	5	⅝-11 Thread	12,200
PF61004	7	⅞	8,600
PF61011	6	⅞	10,200
PF61006	7	⅝-11 Thread	8,600
PF61005	9	⅞	6,600
PF61007	9	⅝-11 Thread	6,600



PFERD ABRASIVES
Grinding Wheels

Type 27 Depressed Center

- Aluminum Oxide abrasive
- Premium performance grinding wheel for steel/stainless(Inox)
- Fast stock removal



Item #	Diameter (in.)	Thickness	Arbor	Max RPM
PF61104	4½	3/16	7/8	13,300
PF61105	4½	¼	7/8	13,300
PF61106	5	¼	7/8	12,200
PF61108	7	¼	7/8	8,600
PF61110	7	¼	5/8-11 Thread	8,600

PFERD ABRASIVES
Grinding Wheels

Saucer Type 28

- Aluminum Oxide abrasive
- For heavy-duty use on steel
- May be used almost flat, which reduces operator fatigue and edge chipping
- Fast stock removal
- 1/4" Thick



Item #	Diameter (in.)	Arbor	Max RPM
PF61703	7	5/8-11	8,600
PF61704	9	5/8-11	6,600

PFERD ABRASIVES
Grinding Wheels

Type 27 Depressed Center

- Aluminum Oxide abrasive
- For use on aluminum, soft metals
- Non-loading
- Very fast stock removal
- 1/4" Thick



Item #	Diameter (in.)	Arbor	Max RPM
PF61301	4½	7/8	13,300
PF61306	7	5/8-11 Thread	8,600
PF61304	7	7/8	8,600

PFERD ABRASIVES
Grinding Wheels

Type 27 Depressed Center

- Silicon Carbide abrasive
- Fast stock removal
- For use on masonry, concrete, stone, gray cast iron and nodular cast iron
- 1/4" Thick



Item #	Diameter (in.)	Arbor	Max RPM
PF61500	4	5/8	15,300
PF61501	4½	7/8	13,300
PF61508	4½	5/8-11 Thread	13,300
PF61502	5	7/8	12,200
PF61504	7	7/8	8,600
PF61506	7	5/8-11 Thread	8,600
PF61507	9	5/8-11 Thread	6,600

PFERD ABRASIVES
Grinding Wheels

Type 27 Depressed Center

- Abrasive: Zirconia Alumina
- Workpiece Materials: Steel, cast iron (grey and nodular types)
- Application: Weld finishing, edge grinding, root pass grinding
- Recommendation for Use: Provides optimum grinding results on pneumatic turbine grinders and powerful high-frequency or electric angle grinders



Item #	Dia. (in.)	Thickness Nominal (in.)	Bore (in.)	Max. RPM
--------	------------	-------------------------	------------	----------

Unthreaded Arbor Hole

PF61602	4½	¼	7/8	13,300
PF61604	5	¼	7/8	12,200
PF61605	7	¼	7/8	8,600

5/8"-11 Threaded Arbor Hole

PF61607	7	¼	-	8,600
PF61608	9	¼	-	6,600

PFERD ABRASIVES

Mandrels

- 1/4" Shaft Size
- 30,000 Max RPM
- For use with Pferd Die Grinder cut-off wheel



Item #	Arbor Size (in.)
PF69026	3/8
PF69027	¼



PFERD ABRASIVES
Grinding Wheels

Type 27 - Depressed Center

- General purpose pipeliner wheel provides smooth grinding action, fast removal rates and good service life
- Abrasive: Aluminum Oxide
- Workpiece Materials: Stainless steel (INOX)
- Application: Surface grinding, edge grinding, root pass grinding
- Recommendation for Use: Achieves Particularly high stock removal rates even at low contact pressure



Item #	Diameter (in.)	Thickness Nominal (in.)	Bore (in.)	Max. RPM
--------	----------------	-------------------------	------------	----------

Unthreaded Arbor Hole

PF63409	4	1/8	5/8	15,300
---------	---	-----	-----	--------

PFERD ABRASIVES
Pipeline Grinding Wheels

Type 27 - Depressed Center

- For light grinding and cutting of pipeliner root pass, weld and flame cut grinding
- Abrasive: A - Aluminum Oxide
- Material: Steel



Item #	Diameter (in.)	Thickness Nominal (in.)	Arbor	Max. RPM
PF63405	4 1/2	1/8	5/8"-11	13,300
PF63402	9	1/8	7/8"	6,600

PFERD ABRASIVES
Snagging Wheels

Flat (Type 1)

- Type 1 wheels for snagging and grinding
- Abrasive: Aluminum Oxide
- Workpiece Materials: Steel, stainless steel (INOX), cast iron
- Application: Grinding in hard-to-reach areas



Item #	Diameter (in.)	Thickness Nominal (in.)	Bore (in.)	Grit	Max. RPM
PF69337	3	1/4	3/8	36	23,000
PF69344	3	1/2	3/8	24	18,000

PFERD ABRASIVES
Reinforced Grinding Wheels for Pipeline

For surface grinding, edge grinding, root pass grinding

- Available in General Purpose and Premium Performance
- Long service life
- Fast cutting action
- For use on Stainless Steel
- Available in 4" through 9" diameters
- For use on air and electric grinders
- 1/8 Thick



Item #	Diameter (in.)	Arbor	Max RPM	Work-piece Material:	Grain	Grit
PF63414	4 1/2	5/8-11 Thread	13,300	Stainless Steel	Aluminum Oxide. Manufactured without addition of ferrous, sulphurous or chlorinated fillers	24
PF63403	7	5/8-11 Threaded	8,600	Carbon Steel	Aluminum Oxide	24
PF63404	9	5/8-11 Thread	6,600	Carbon Steel	Aluminum Oxide	24



SPECIFIED TECHNOLOGIES

Fire Barrier Sprays

SpecSeal® AS200 Series

- Top of wall spray
- Original quick-dry elastomeric formula
- Water-based - for easy installation, clean-up and disposal
- Thixotropic - superior high-build properties
- Safe - low VOCs, no solvents, non-halogenated
- Auto-bonding - may be re-coated or repaired using ES Caulk
- Low abrasion - for longer pump life and less maintenance
- Tested with spray applied fire resistive material (SFRM)
- Acoustically tested - reduces noise transmission
- Water-resistant - will not re-emulsify when dry



Item #	Desc.
STIAS205	5 gal.
STIAS205R	5 gal. (Red)

SPECIFIED TECHNOLOGIES

Intumescent Collars

SpecSeal® Series Collar

- The economical solution for firestopping common plastic pipe that doesn't compromise safety or performance
- Easy installation - uses STI's quick closure design
- Compact profile - use it in all the tight spots
- Water-resistant - no water soluble or hygroscopic ingredients
- Fast-acting expansion (up to 60X) - to seal off burning pipes
- Safe for contact with plastics



Item #	Desc.
STILCC150	1.5" Dia Plastic Pipe
STILCC200	2.0" Dia. Plastic Pipe
STILCC300	3.0" Dia. Plastic Pipe
STILCC400	4.0" Dia. Plastic Pipe
STISSC600	6.0" Dia. Plastic Pipe

**Need Firestop
Training?
Call Edge Today!**

SPECIFIED TECHNOLOGIES

Intumescent Collar

SpecSeal® Series RTC Collars

- Rapid Expansion - Closes off burning pipes quickly
- Small Profile - Use it in all the tight spots
- Flexible & Durable - No loose flakes (eye hazards)
- Water Resistant - No water soluble or hygroscopic ingredients
- Economical - Lower installed cost
- High Volume Char - Expands up to 60 times



Item #
STIRTC350

SPECIFIED TECHNOLOGIES

Fire Barrier Composite Sheets

- Lightweight for easy handling and fabrication and less hanging weight on walls
- Easy to cut using sheet metal tools
- Highly intumescent – expands up to 15X
- Hole Reduction – Used in conjunction with other SpecSeal or EZ-Path® Products for reducing large openings



Item #	Size (in.)
STICS1628	16 x 28
STICS2436	24 x 36
STICS3641	36 x 41

SPECIFIED TECHNOLOGIES

Firestop Sleeve Kit

SpecSeal® Ready Sleeve™

- Seals off the path of fire, smoke and superheated gases while providing support and protection for electrical, telephone, and data cables
- Economical – Significant material and labor savings vs. field fabrication
- No External Firestop Seal Required – Factory supplied intumescent firestop gasket eliminates the need to seal the circumference of the steel sleeve at its egress from each side of barrier
- UL® Classified and Code Compliant – Each kit designed to provide up to a 2 hour F Rating in accordance with UL® System requirements; assures code compliance every time
- For Rated and Non-Rated Barriers – Putty seal impedes the passage of fire, smoke, superheated gases, and particulate dust, and minimizes noise transmission



Item #	Desc.
STIFS100	1" sleeve
STIFS200	2" sleeve
STIFS400	4" sleeve



SPECIFIED TECHNOLOGIES

Firestop Sleeve Kit

SpecSeal® Ready™ Split Sleeve



- The only UL® Classified Firestop Sleeve for use in oversize openings
- Smooth cable entry — Unique rolled lip eliminates potential sharp edges and the need for conduit bushings
- Sturdy, lightweight — At half the weight of threaded products, and with fewer parts required
- Cable management — Inspector-friendly wall labels included with every kit
- UL Tested and Classified in accordance with ASTM E 814 (UL 1479) with F Ratings up to 4 hours

Item #	Size (in.)	Plate Diameter (in.)	Min. Opening (in.)	Max. Opening (in.)
STIFSR100	1	3x3	1.16	2.25
STIFSR200	2	4.5x4.5	2.38	4.0
STIFSR400	4	8x8	4.5	6.0

SPECIFIED TECHNOLOGIES

Fire Barrier Mortar

SpecSeal®



- Light weight/low density - less forming and support required; easy retrofit
- Fast drying - forms come down faster
- Economical - highest yield per pound means lower installed cost
- Wide range of application - includes aluminum cable tray.
- Red color - easy identification and inspection
- Chemical adhesion - reduces the need for expensive and time-consuming concrete fasteners
- Trowelable and self-leveling

Item #	Desc.
STISSM106	Poly Pail, 22 lb.

Mineral Wool

- Packing material for firestop systems
- Excellent heat insulator with fire-resistant qualities
- easy to cut 2"x24"x48" sheets

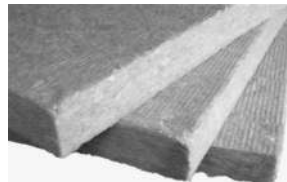

5 per pkg.

Item #
3MMMINERALWOOL

SPECIFIED TECHNOLOGIES

Firestop Pillows

SpecSeal®



- Intumescent - expands in all directions for a tough, tight seal
- Reinstallable - for easy retrofitting of cables
- Heat-sealed poly bag protects core and makes pillows slide in and out easier
- Monolithic encapsulated core - no loose fill, tougher, more resilient
- Superior air leakage rating
- UL, cUL classified and FM approved and meets the exacting criteria of ASTM E814 (UL1479).

Item #	Dimension (in.)	Std. Pkg. Qty.
STISSB14	1 x 4 x 9	20
STISSB24	2 x 4 x 9	10
STISSB26	2 x 6 x 9	22
STISSB36	3 x 6 x 9	16

SPECIFIED TECHNOLOGIES

Intumescent Wrap Strips

SpecSeal®



Incredible intumescent power for protecting plastic industrial piping and other combustible penetrants

- Easy Installation - soft and flexible, less strip and less fasteners needed
- Rapid Expansion - closes off burning penetrants faster
- High Volume Char - significant expansion seals off opening
- Water-Resistant - no soluble or hygroscopic ingredients
- Highly Flexible - no foil...soft...supple...easier to install
- Versatile Performer - for a wide range of complex applications

Item #	Desc.
STISSWBLU	Blue Wrap Strip (2"Wx3/16"Tx12'L)
STISSWRED	Red Wrap Strip (1.5" W x 1/4" T x 12' L)
STISSWRC2	Metal Restraining Collar 25' (For use with SSWRED)

SPECIFIED TECHNOLOGIES

Smoke 'N' Sound Sealant & Spray

SpecSeal®



- Economical - high performance without the high price
- Safe for contact with plastics
- Water Resistant - will not re-emulsify when dry
- Water-Based - easy installation, cleanup, and disposal
- Remains Flexible - allows movement
- Acoustically Tested - reduces noise transmission
- Low VOCs, Safe, No solvents, Non-Halogenated

Item #	Desc.
STISNS120W	White Sealant, 20 oz. Sausage
STISNS205	Spray, 5 Gal. Pail



SPECIFIED TECHNOLOGIES

Intumescent Firestop Putty

SpecSeal®



- Non-Hardening - for easy retrofit
- Patented two-stage intumescence - extremely fast and aggressive expansion
- Endothermic fillers - absorb heat and release water
- Highly adhesive - stays put, allows movement
- Soft and pliable - for easy installation
- No water-soluble expansion ingredients - means better water resistance
- Sound deadening - excellent sound attenuation, reduces noise transmission
- UL®, cUL classified and FM approved
- Meets requirements of ASTM E814 and to the time/temperature requirements of ASTM E119

Item #	Desc.
STISSP100	36 cu. in. Putty Tube
STISSP4S	Putty Pad 7.25 x 7.25 x 3/16 in.
STISSP9S	Putty Pad 9 x 9 x 3/16 in.

SPECIFIED TECHNOLOGIES

Intumescent Sealants

SpecSeal® Triple S®



- Water based - for easy installation, cleanup and disposal
- Patented two-stage intumescence - extremely fast and aggressive expansion
- Remains flexible - allows normal pipe movement
- Sandable and paintable (when dry)
- Water resistant - will not re-emulsify when dry
- Safe for contact with plastics
- Red color - for easy identification and inspection
- Multi-viscosity grade - means excellent caulking properties along with high build capabilities
- Excellent smoke seal
- UL®, cUL classified and FM approved

Item #	Desc.
STISSS100	10.1 oz. Tube
STISSS120	20 oz. Sausage
STISSS129	29 oz. Tube
STISSS105	5 gal. Pail

TIP: Make sure to follow the UL LISTED Firestop system - call Edge for help.

SPECIFIED TECHNOLOGIES

Intumescent Firestop Sealants

LCI SpecSeal®



- Economical - high performance without the high price
- Highly intumescent - expands up to 10X
- Excellent smoke seal
- Safe for contact with plastics
- Water resistant - will not re-emulsify when dry
- Water based - for easy installation and cleanup
- Acoustically tested - reduces sound transmission
- Low VOCs - safe, no solvents, non-halogenated
- Pale red color - for easy identification
- UL®, cUL classified and FM approved

Item #	Desc.
STILCI300	10.1 oz. Tube
STILCI305	5 gal Pail
STILCI320	20 oz. Sausage
STILCI329	29 oz. Tube

SPECIFIED TECHNOLOGIES

Elastomeric Sealant SpecSeal®



- Elastomeric - allows movement
- Water-based - easy installation, clean up and disposal
- Auto-bonding - fresh material adheres to previously installed product
- Compatible with AS Spray for applications or repairs
- Safe - low VOCs, no solvents, non-halogenated
- Water-resistant - will not re-emulsify when dry
- Acoustically tested - reduces noise transmission

Item #	Desc.
STIES129	29.0 oz. Tube
STIES120	20 oz. Sausage
STIES105	5 Gal. Pail

SPECIFIED TECHNOLOGIES

Cable Pathway and Firestop

Series 22 EZ-Path™



- Designed for new or existing cable installations through walls (only) up to 9" thick and holds up to 24 CAT 5E cables
- Pathway can be mounted as a single unit in either a 2" round or a 1-1/2" x 1-1/2" square opening
- Height x Width: 1-1/2" x 1-1/2"
- Length: 10-1/2"
- Fire rated in walls up to 4 hrs.

Item #	Desc.
STIEZD22	Device Kit, (2) Wall Plates and (1) Device



SPECIFIED TECHNOLOGIES
Cable Pathway and Firestop Devices

**Series 33
EZ-Path™**



- No firestopping required - always firestopped
- Self-contained firestop system - automatically adjusts to cable loads
- Easily moves, adds, and changes
- The compact square design (3" x 3" x 10-1/2" long) provides greater cable loading than a conventional 4" sleeve, cables can be added or changed without the need to remove and re-install firestopping materials
- Offers a clean, professional, engineered appearance; the device is colored safety orange and comes with wall labels for easy identification
- Splits apart for "old work"
- UL® classified up to 4 hours and FM approved in accordance with ASTM E814 (UL1479)
- Fire rated in walls up to 4 hrs.
- Fire rated in floors up to 4 hrs.
- Ask about other kits and adapters
- Ask about ganging multiple devices together

Item #	Desc.
STIEZD33FWS	Device
STIEZDP33FWS	Device Kit, (2) Wall Plates and (1) Device

SPECIFIED TECHNOLOGIES
Cable Pathway and Firestop

**Series 33 Seven Gang Kit
EZ-Path™**



- Seven gang kit designed to allow seven Series 33 Pathways to be installed in a 3" x 21" opening
- Attachment plates can be fastened to studs spaced 24" O.C. as the wall is being built or they can be installed in finished walls

Item #
STIEZDP733GK

SPECIFIED TECHNOLOGIES
Cable Pathway and Firestop Devices

**Series 44
EZ-Path®**



- Designed for new or existing cable installations up to 10" thick through walls or floors
- The Ez-Path® Series 44 pathway holds up to 240 CAT 5E cables
- Pathways can be ganged for additional capacity
- Height x Width: 4" x 4-5/8"
- Length: 14"
- Can be ganged up to 5 in walls and up to 16 in floors
- Fire rated in walls up to 4 hrs.
- Fire rated in floors up to 4 hrs.

Item #	Desc.
STIEZD44	Device Only

SPECIFIED TECHNOLOGIES
Cable Pathway and Firestop

**Series 44 Modular Floor grid Sytem
EZ-Path®**

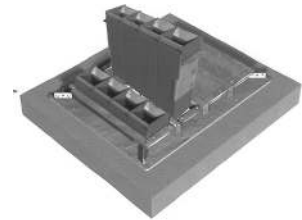

- The Ez-Path Modular Floor Grid system can handle literally thousands of cables
- Modular Floor Grid Systems utilize the high volume, EZ-Path 44 Series Pathways installed in banks of four to provide your cabling systems with room to grow
- Sturdy steel grids mount one, two or four banks of pathways in built-in slots for a total of up to sixteen pathways through a single floor opening. A single bank Floor Grid comes complete with firestop panels sealing each slot. As additional cable capacity is required, firestop panels are removed and pathway modules containing four pathways are installed in each slot
- Ask for help with your configuration
- Many options available

Item #	Desc.
STIEZDG444	Single Slot Grid, Complete With Grid and Four Pathways
STIEZG844	Dual Slot Grid Only, 8 Pathway Capacity, With Firestop Panels to Seal Unused Slots
STIEZG1644	Four Slot Grid Only, 16 Pathway Capacity, With Firestop Panels to Seal Unused Slots
STIEZD444MB	Four Pathways and Hanger Brackets for use in EZG844 and EZG1644

Low-voltage firestop pathways: EZ-Path

- Always in compliance even if more cables are added in the future
- Can have a single pathway or gang multiple together



SPECIFIED TECHNOLOGIES

Ready® Firestop Grommet

- Single Cable Penetrations can be time consuming, expensive, and messy. Now there is a new solution from the cabling innovators at STI. Ready Firestop Grommets make membrane and through-penetrations through rated gypsum board walls a snap. Just drill a hole, run your cable, snap the grommet around the cable, and press it into the wall. Use a single grommet for single sided (membrane) penetrations, or drill a hole through both sides of the wall and install grommets back-to-back for through penetrations
- Ready Firestop Grommet is molded from a premium grade plenum-rated polymer. A soft foam inner core conforms to the cable to form a tight seal. The foam is smoke-sealed and firestopped in just minutes with no sleeve, and no sealant or putty required
- Quick to install - 2 piece grommet snaps together for an easy installation
- Economical - Eliminates Sleeves and the need for putty or sealant
- Split design - Can be used with previously installed cables
- Made with Ultem® premium, plenum-grade material - Exceptional flame & heat resistance
- Low voltage cables up to .027 in. O.D.
- 1 & 2 Hr rated gypsum board walls
- Single membrane or through-penetrations



Ready Firestop Grommets were tested to meet the exacting criteria of ASTM E814 (UL1479) and CAN/ULC S115. Tested systems provide up to 2 hr. fire ratings for single cable penetrations in gypsum board/stud wall assemblies

Item #	Color	Overall Length	Req. Opening
STIRFG1	Red	1 5/8"	9/16"

SPECIFIED TECHNOLOGIES

Cast-In Firestop Device

SpecSeal®

- The devices install easily and quickly. Simply position the sleeves as required, fasten to the form and pour the concrete
- The molded plastic body can be cut to adjust to the depth of the pour and is tough enough to resist the rigors of the concrete finishing process
- A variety of accessories permit installation under many construction conditions including variations in concrete depth and installation over pan decks
- The unique chambered intumescent system expands rapidly in the event of a fire to provide up to a three hour fire rating. A resilient



gasket system seals against the propagation of smoke and provides additional protection against water exposure

- UL listed products

Application:

- 2", 3", 4" and 6" trade size plastic or metallic pipes
- Insulated metallic pipes
- Cable bundles
- Concrete ranging in depth from 2-1/2" to 8"
- Concrete greater than 8" using available extension tubes
- Concrete over steel deck using available Deck Adapter Kit
- Do not use for wall applications

Dimensions:

- 2" ID: Footprint 5-1/8" x 5-1/8" ; Min. Steel Deck Opening 3-5/8"
- 3" ID: Footprint 5-3/4" x 5-3/4" ; Min. Steel Deck Opening 4-1/4"
- 4" ID: Footprint 6-3/4" x 6-3/4" ; Min. Steel Deck Opening 5-1/4"
- 6" ID: Footprint 9" x 9" ; Min. Steel Deck Opening 7-1/4"
- SpecSeal® Cast-In Firestop Devices have been successfully tested in accordance with ASTM E814 (ANSI/UL1479) in one, two and three hour fire-rated floor assemblies. Consult factory for individual system designs and application requirements

Item #	Desc.	Case Qty.
--------	-------	-----------

Devices for Combustible and Noncombustible Penetrants

STICD200	2" Trade Size Cast-In Firestop Device	6
STICD300	3" Trade Size Cat-In Firestop Device	6
STICD400	4" Trade Size Cat-In Firestop Device	6
STICD600	6" Trade Size Cat-In Firestop Device	6

Devices for Non-Combustible Penetrants

STICD200M	2" Trade Size Cast-In Firestop Device	6
STICD300M	3" Trade Size Cat-In Firestop Device	6
STICD400M	4" Trade Size Cat-In Firestop Device	6
STICD600M	6" Trade Size Cat-In Firestop Device	6

Extension Tubes

STICD200X	2" Trade Size Extension Tube	6
STICD300X	3" Trade Size Extension Tube	6
STICD400X	4" Trade Size Extension tube	6
STICD600X	6" Trade Size Extension Tube	6

Deck Adaptor Kits

STICD200K	2" Trade Size Metal Deck Adaptor	6
STICD300K	3" Trade Size Metal Deck Adaptor	6
STICD400K	4" Trade Size Metal Deck Adaptor	6
STICD600K	6" Trade Size Metal Deck Adaptor	6

Call for submittal information



SPECIFIED TECHNOLOGIES T-Collar™ Penetrant Heat Sinking Device

SpecSeal®

- The SpecSeal® T-Collar™ Penetrant Heat-Sinking Device is a patented design utilizing sealed thermal heat sink packs, protected by a strong metal outer shell
- The device is secured directly to metal pipes or conduits on the top side of floors or on both sides of walls
- Combined with appropriate SpecSeal® Firestop Products, UL Systems incorporating this device have been tested to provide T ratings up to 2 hours
- Easy to Install and requires no ampacity derating; safer than insulating
- Code Compliant solutions for T ratings
- Easily identifiable to ease the inspection process
- Where codes require equal F and T ratings, the SpecSeal® T-Collar™ (in conjunction with appropriate SpecSeal® Firestop Sealants) is used as a heat-sinking device to reduce temperature transmission through metallic pipes and conduits
- SpecSeal® T-Collar™ Penetrant Heat Sinking Devices have been successfully tested in conjunction with SpecSeal® Firestop Products in accordance with ASTM E814, ANSI/UL1479, and for individual system designs and application requirements



Item #	Description
STITC200	2" Penetrant Heat Seeking Device
STITC300	3" Penetrant Heat Seeking Device
STITC400	4" Penetrant Heat Seeking Device



3M FIRE PROTECTION PRODUCTS

Fire Barrier Caulks

- Water-based - easy cleanup and routine disposal with no special handling
- One-part system - no mixing or measuring required
- Intumescent and endothermic properties
- No-sag, non-halogen formula
- Fast-drying - tack-free in approximately 10-15 minutes
- Provides up to 4 hour F-rating
- Paintable
- Documented aging properties



Item #	Size	Package Type
3MCP25WB	10.1 oz	Cartridge
3MCP25WB-27	27 fl. oz.	Cartridge
3MCP25WB-5	5 gal	Pail

3M FIRE PROTECTION PRODUCTS

Fire Barrier Caulks

- A water based latex, intumescent smoke and firestopping sealant for wall and floor penetrations.
- Easy-to-handle formulation that bonds to gypsum wallboard, concrete, metals, wood, plastic and cable jacketing.
- Dries to a firm, rubber-like solid
- Provides up to 2 hours F-rating
- Distinctive yellow color makes inspections easier



Item #	Desc.	Package Type
3MIC15WB	10.1 fl. oz.	Cartridge

3M FIRE PROTECTION PRODUCTS

Fire Barrier Sealant

- Tested and approved for single metallic pipe penetrations and construction joints
- Water-based for easy installation cleanup and disposal
- High-solids formula means no shrinkage
- Provides up to 3-hour fire rating
- Excellent movement capabilities



Item #	Size	Package Type
3MFD150+BLUE	10.1 fl. oz.	Cartridge
3MFD150+LIMESTONE	10.1 fl. oz.	Cartridge
3MFD150+28BLUE	28 fl. oz.	Cartridge
3MFIREDAM 150+4.5 BLUE	4.5 gal	Pail
3MFD150+4.5LIMESTONE	4.5 gal	Pail

3M FIRE PROTECTION PRODUCTS

Fire Barrier Silicone Sealant

- Premium sealant available in non-slump formula
- Compression/extension recovery of + or - 31% of original joint width
- Re-enterable/repairable
- One part silicone elastomer-cures upon exposure to atmospheric humidity
- Provides up to 4 hour fire rating



Item #	Size	Package Type
3M2000	10.3 fl. oz.	Cartridge

3M FIRE PROTECTION PRODUCTS

Fire Barrier Moldable Putty

- Pliable-conforms into almost any shape
- Will not dry out or crumble
- Provides up to 3-hour fire rating



Item #	Size (in.)
3MMPP+	7 x 7 x 1/8 Pad
3MMPP+9	9 1/2 x 9 1/2 x 1/8 Pad
3MMPS-2+	1.4 x 11 Stix



3M FIRE PROTECTION PRODUCTS

Fire Barrier Sprays

FireDam™

- High coverage rate reduces installation time
- Fast dry, low-sag formula
- Gray color blends with concrete and gypsum
- Applies with conventional airless spray equipment
- Paintable when cured
- Applies as 1/8" wet coating, dries to 1/16"
- Easy clean-up with water
- Provides 4-hour fire rating



Item #	Size (gal.)	Package Type
3M FIRE DAM SPRAY 200	5	Pail

3M FIRE PROTECTION PRODUCTS

Fire Barrier Mortar

This lightweight cementitious firestop with excellent adhesion bonds to concrete, metals, wood, plastic and cable jacketing.

- Variable mix ratio - permits self-leveling and no-sag application consistencies
- Re-enterable
- Bonds to itself - proven prior to and during fire testing
- Pumpability - allows faster installation
- Contains no asbestos
- Non-shrinking, non-load formula
- 44 lb. bag (yields a minimum 2 ft. square at a 4" depth)



Item #
3MMORTAR

3M FIRE PROTECTION PRODUCTS

Fire Barrier Pillows

- Stackable and conformable
- No wire mesh or graphite
- Excellent aging properties
- Provides up to 3-hour rating



Item #	Size (In.)	Packaging per Case
3MFB249	2 x 4 x 9	24
3MFB269	2 x 6 x 9	16
3MFB369	3 x 6 x 9	20

3M FIRE PROTECTION PRODUCTS

Fire Barrier Composite Sheets

- Ideal for fire-stopping blank openings and through-penetrations of multiple cable, pipe ducts, buss ducts and cable trays
- Intumescent
- Lightweight and easy to handle - just cut and form to fit
- Easy to install using common trade tools
- Easy to fasten - bolt punch or drill through and use self-tapping screws or anchor bolts
- No mixing or damming required
- Re-enterable and provides up to 4-hour fire rating



Item #	Size (in.)
3MCS-195-3X2	36 x 24
3MCS-195-3X3	36 x 36
3MCS-195-3X41	36 x 41

3M FIRE PROTECTION PRODUCTS

Fire Barrier Wraps/Strip

- One-part, intumescent and elastomeric strip with foil on one side
- Can be cut to irregular shapes
- Used with restricting collar or caulk
- Provides up to 4-hour fire rating

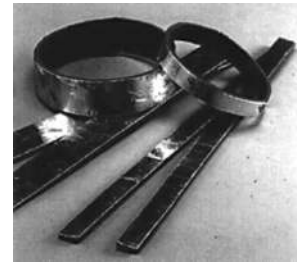

Item #	Size (in.)
3MFS-195	2 x 24

3M FIRE PROTECTION PRODUCTS

Fire Barrier Restricting Collar

- Works in conjunction with 3M™ FS-195+ wrap/strip or 3M™ Interam™ Ultra GS
- 28-gauge steel
- Convenient 25-foot roll - cut only what you need
- Required for firestopping plastic pipes larger than 4"

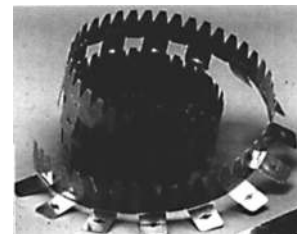

Item #
3MRC-1

3M FIRE PROTECTION PRODUCTS

Duct Wraps

FireMaster®

- Patented inorganic blanket encapsulated with a reinforced aluminum foil
- Used to fire rate commercial kitchen grease, air, and chemical exhaust ducts
- High flexibility and strength for easy installation
- Stitched for easier handling and no slumping



Item #	Size
3M15A	1 1/2" x 24" x 20' roll

3M

3M FIRE PROTECTION PRODUCTS **Ultra Plastic Pipe Devices**

- Ultra-fast anchoring system secures device to most substrates without power tools
- One-piece construction
- Intumescent action quickly seals off the penetrating item in a fire
- Provides up to 3-hour fire rating



Item #	Desc.
3MULTRAPPD1.5	For 1.5" pipe
3MULTRAPPD2.0	For 2" pipe
3MULTRAPPD3.0	For 3" pipe
3MULTRAPPD4.0	For 4" pipe

3M FIRE PROTECTION PRODUCTS **Fire Barrier Cast-In Devices**

- Adapts to any depth of concrete pour
- Devices for both metal and plastic pipes
- One-step firestopping, no need to core drill holes and firestop later
- Can be used on flat forms or fluted metal decks
- No need to caulk, use plastic pipe devices or wrap strips
- Provides up to 3 hour fire rating



Item #	Diameter (in.)
For Metal Pipes	
3M2MCID	2
3M3MCID	3
3M4MCID	4
3M6MCID	6
For Plastic Pipes	
3M2PCID	2
3M3PCID	3
3M4PCID	4
3M6PCID	6

3M FIRE PROTECTION PRODUCTS

Fire Barrier Cast-In Tub Box Assembly

- Used primarily for new installations
- Fastens to the Cast-In Device
- Creates a void for plumbing access.
- The adaptor contains a 2" foam insert when a 2" deep access void is needed
- For use with 3M Cast-In Devices
- Accommodates plastic and metal pipes
- UL tested systems



Item #	Desc.
3M2TB	For use with 2PCID & 2MCID
3M3TB	For use with 3PCID & 3MCID

3M FIRE PROTECTION PRODUCTS

Fire Barrier Cast-In Height Adaptor

- This one-piece plastic device is easy to install
- Use it on fluted steel pan decks for drain, waste, and vented or closed pipe systems
- For use with 3M Cast-In Devices
- One-stop firestopping fluted metal decks
- Accommodates plastic and metal pipes



Item #	Desc.
3M2HA	For use with 2PCID & 2MCID
3M3HA	For use with 3PCID & 3MCID
3M4HA	For use with 4PCID & 4MCID

3M FIRE PROTECTION PRODUCTS

Fire Barrier Cast-In Deck Adaptor

- This one-piece plastic device is easy to install
- Use it on fluted steel pan decks for drain, waste, and vented or closed pipe systems
- For use with 3M Cast-In Devices
- One-stop firestopping fluted metal decks
- Accommodates plastic and metal pipes



Item #	Desc.
3M2MDA	For use with 2PCID & 2MCID
3M3MDA	For use with 3PCID & 3MCID
3M4MDA	For use with 4PCID & 4MCID



SONNEBORN
Industrial Sealant

Div.7 07 92 00

Sonolastic® NP 1™

NP 1™ is a one-component, high-performance, nonpriming, gun-grade, elastomeric polyurethane sealant. It requires no mixing and typically requires no priming to bond to many materials, including concrete and masonry.

Features:

- Ready to use
- Joint movement capability ±35%
- Easy to gun and tool
- No primer required for most construction materials
- Weather resistant Packaging
- Wide temperature-application range
- Compatible with nonrigid coatings
- Superior holding power
- UL listed
- Suitable for water immersion
- Low VOC content

Application:

- Expansion joints, Curtain wall construction, Panel walls, Precast units, Aluminum and wood window frames, Roofing, Fascia, Parapets, Structural components, Vinyl siding, Wastewater treatment plants, Dams, Spillways and storm drains, Wetwells and manholes



Item #	Size	Color	Pack
SO32-957	10.1 oz cartridge	Special Bronze	30
SO32-957PP	20 oz sausage	Special Bronze	20
SO32-961	10.1 oz cartridge	White	30
SO32-961PP	20 oz sausage	White	20
SO32-962	10.1 oz cartridge	Off White	30
SO32-963	10.1 oz cartridge	Limestone	30
SO32-963PP	20 oz sausage	Limestone	20
SO32-964	10.1 oz cartridge	Stone	30
SO32-964PP	20 oz sausage	Stone	20
SO32-965	10.1 oz cartridge	Tan	30
SO32-965PP	20 oz sausage	Tan	20
SO32-966	10.1 oz cartridge	Black	30
SO32-966PP	20 oz sausage	Black	20
SO32-967	10.1 oz cartridge	Aluminum Gray	30
SO32-967PP	20 oz sausage	Aluminum Gray	20
SO32-968	10.1 oz cartridge	Medium Bronze	30
SO32-969	10.1 oz cartridge	Redwood Tan	30
SO32-970	10.1 oz cartridge	Hunter Green	30
SO32-971	10.1 oz cartridge	Anodized Aluminum	30

SONNEBORN
Joint Sealants

Div.7 07 92 00

Sonolastic® 150

Sonolastic® 150 with VLM Technology is a premium, very low-modulus, high-movement, nonsag, fast-curing, ready to-use, silyl-terminated polyethersealant. It combines the best qualities of organic and silicone sealants to keep moving joints weathertight



- Superior Adhesion: Long term Bond – reduced call backs
- Very low modulus: Accommodates extreme joint movement (100% extension in EIFS joints with little stress on bond line)
- Compatible with nonrigid coatings: May be painted soon after installation
- Easy to gun and tool: Speeds application; makes neater joints
- Ready-to-use 1 component: Reduces labor; speeds application
- Wide temperature application range: Use in all climates
- Weather resistant: Provides long-lasting weathertight seals
- Fast curing: Speeds jobsite production
- Nonstaining: Use safely on stone and other sensitive substrates
- Mildew resistant: Does not support mildew growth; offers low-odor alternative for sanitary areas
- Available in ProPaks: Reduces jobsite waste; lowers disposal costs
- Very low VOC's (2 g/L): Meets all State and Federal regulations

Item #	Color	Size
SO51703714	Aluminum Gray	10.14 oz.
SO51703820	Black	10.14 oz.
SO51704032	Limestone	10.14 oz.
SO51704138	Medium Bronze	10.14 oz.
SO51704244	Off White	10.14 oz.
SO51704350	Redwood Tan	10.14 oz.
SO51704562	Slate	10.14 oz.
SO51704668	Special Bronze	10.14 oz.
SO51704774	Stone	10.14 oz.
SO51704880	Tan	10.14 oz.

**Ask Edge
for product
specifications
& submittal
information.**



WHITE LIGHTNING® CAULKS & SEALANTS
100% RTV Silicone Sealants

White Lightning®

- HIGH HEAT RED
- Performs from -85°F to 500°F continuously
- Withstands 600°F intermittently
- Non-sagging, non-slumping for overhead or vertical surfaces
- Will not crack, crumble or shrink
- Excellent weathering performance and adhesion
- Remains uniform and flexible over wide temperature range
- Size: 10 oz. cartridge



Item #
KRWL09611

WHITE LIGHTNING® CAULKS & SEALANTS
100% RTV Silicone Sealants

White Lightning®

- SILICONE RUBBER
- Use for interior and exterior projects
- Highly, permanently flexible, provides watertight seal
- Will not crack, crumble, or shrink
- Resists moisture and mildew
- Excellent adhesion to non-porous materials
- NSF and USDA compliant
- Size: 10 oz. tube



Item #	Desc.
KRWL09010	Clear
KRWL09210	White
KRWL09310	Aluminum
KRWL09410	Black
KRWL09023	Clear

WHITE LIGHTNING® CAULKS & SEALANTS
Acrylic Latex Caulks

White Lightning®

- Can be used in interior & exterior applications
- Applies a smooth, professional bead without gaps or air bubbles
- Maintains superior flexibility and elasticity
- Excellent color retention
- Cured caulk resists rust and mildew
- Can be painted or stained after curing
- 10-oz. plastic cartridge



Item #	Desc.
KRWL30060	White



OSI
**Heavy-Duty Sub-Floor
& Construction Adhesive**
Pro Series®

- Cold weather formula provides excellent adhesion and easier extrusion
- Can be applied directly to dry, wet or frozen lumber
- It offers fast set, superior strength development and is compatible with most building materials
- Will bridge minor gaps when bonding irregular surfaces, ultimately reducing squeaky floors
- Can be used in interior or exterior applications
- Waterproof and weatherproof



Item #	Cartridge Size (fl. oz.)	Color
OISF-450	28	Tan

OSI
Sub-Floor & Deck Adhesive
Green Series®

- Ultra Low VOC content meets stringent State and Federal VOC requirements
- For Glued Floor Systems and other general construction needs, interior or exterior.
- High performance, non-flammable, low gassing
- Will bridge minor gaps when bonding irregular surfaces
- Can be applied directly to dry, wet or frozen lumber



Item #	Size (fl. oz.)	Color
OI1020004	28	White

OSI
Metal Framing & Drywall Adhesive
Pro Series®

- High initial grab helps eliminate nail pops
- Provides sufficient open time for the positioning of gypsum panels
- Rapid bond development
- Bridges minor framing irregularities
- Unaffected in cold weather use
- After cure, bond is flexible enough to allow for structural movement due to settling
- Waterproof and weatherproof



Item #	Cartridge Size (fl. oz.)	Color
OIF-38	28	Tan



OSI
**Multi Purpose
Construction Adhesive**
Pro Series®

- High initial grab minimizes nailing requirements
- Waterproof and weatherproof - Can be used in interior or exterior applications
- Will bridge minor gaps when bonding irregular surfaces



Item #	Cartridge Size (fl. oz.)	Color
OIQB-300	28	White

OSI
Acoustical Sound Latex Sealant
Pro Series®

- Ultra low VOC formulation meets the strictest of State and Federal VOC regulations
- Qualifies for LEED® building certification points
- Water based, easy clean-up with water
- Permanently flexible will not harden, crack or separate over time
- Bonds to most building materials
- Reduces sound transmission
- Low odor



Item #	Cartridge Size (fl. oz.)	Color
OISC-175	28	White

OSI
Pro Foam II
Minimally Expanding Insulation
Green Series®

- Low foam pressure/low expansion product will not warp or deform windows or doors
- Aids in filling gaps or cracks to eliminate drafts and sound transmission
- High insulating value - Provides an R factor of 5 per inch of foam
- Closed foam structure will not absorb moisture
- Quick setting formulation - Can be cut or trimmed in less than 1 hour
- Will not harden or crack out over time
- Adheres to all types of wood, metal, concrete, brick, glass, drywall, most plastics and other building materials



Item #	Size (oz.)	Color
O1183480	29	White

OSI
Heavy-Duty Construction Adhesive

**Loctite®
Power Grab®**

- 9x higher instant grab than traditional adhesives
- Exterior / Interior water resistant formula
- Paintable & water clean-up
- Suitable for indoor and outdoor applications
- Low odor



Item #	Size (oz.)	Color
O1841989	10.1	White



NEWBORN BROTHERS
Economy Caulk Gun

Smooth Rod Cradle

- 10:1 Thrust Ratio
- 1/10 gal. capacity
- Seal Puncture Tool / Spout Cutter
- Ladder Hook



Item #
NE101

NEWBORN BROTHERS
Caulk Gun

Hex Rod/Parallel Frame

- 10:1 Thrust Ratio
- E-Z Thrust
- E-Z Load Front Cap
- Ladder Hook



Item #	Size (gal.)
NE111	1/10
NE125	1/4

NEWBORN BROTHERS
Caulk Gun

Super Ratchet Rod Cradle

- 6:1 Thrust Ratio
- Seal Puncture tool / Spout Cutter
- Ladder Hook
- Finger Guard
- 1/10 gal. Capacity



Item #
NE188



NEWBORN BROTHERS
High Thrust Caulk Gun

Super Smooth Rod/Revolving Frame

- 18:1 Thrust Ratio
- Revolving Barrel
- Seal Puncture Tool
- Spout Cutter
- Ladder Hook
- Thumb Release
- Zinc Alloy Handle



Item #	Size (gal.)
NE250	1/10
NE255	1/4

NEWBORN BROTHERS
Bulk/Sausage Caulk Gun

Smooth Rod

- 18:1 Thrust Ratio
- Lightweight Aluminum
- Multi-Chemical Resistant Twin Hytrel Cup
- Bulk/Sausage Conical Ejector
- 3 PC-620 Cones Included
- Zinc Alloy Handle



Item #	Size
NE620-AL	24 oz. Bulk, 10 oz. & 20 oz. Sausage Packs, 10 oz. Cartridge

NEWBORN BROTHERS
Bulk/Sausage Caulk Gun



Deluxe Hex Rod

- Adjustable Thrust Ratio (14:1 or 7:1)
- Patented Gator Trigger™ Comfort Grip
- Rotating Barrel with Lock
- Ring Cap and 3 Cones Included
- OV-25 Oval Nozzle Included (1/2")
- Leather Cups Standard with Floating Sausage Cup
- Effective Trigger Grip (ETG) for Longer Rod Life

Item #	Size
NE624	24 oz. Bulk, 10 oz. and 20 oz. Sausage Packs
NE632	32 oz. Bulk, 10 oz., 20 oz. and 30 oz. Sausage Packs

NEWBORN BROTHERS
Dual Component Caulk Gun

- 26:1 Thrust Ratio
- Dispenses 300ml x 300ml; 300ml x 150ml; 150ml x 150ml; 150ml x 75ml
- Easily Converts in Just Seconds with Patented Snap In / Snap Out Push Disks
- Patented Cartridge Stabilizing Plate for Extra Cartridge Support
- Extra Durable Heated Treated Piston Rod to Last Longer Than Comparable Models
- Precision Sintered Friction Plate
- Easy Release Star-Burst Reverse Gripping Plate



Item #
NE535-XSP

NEWBORN BROTHERS
Caulk Gun Cone Accessory

- Green Plastic to be used with 2" Barrel (with RCP-60 Ring Cap)
- Yellow Plastic to be used with Sausage Guns

Item #	Description
NEPC-58	Green
NEPC-620	Yellow



NEWBORN BROTHERS
Caulk Gun Nozzles

Item #	Desc.
NEOV-17	3/16" I.D. Oval End
NEOV-18	1/4" I.D. Oval End
NEOV-21	3/8" I.D. Oval End
NEOV-25	1/2" I.D. Oval End
NER-10	3/32" I.D. Round End
NER-11	1/8" I.D. Round End



NEWBORN BROTHERS
Caulk Spatulas

Item #	Desc.	Width (in.)
NESPT-10S	10" Straight	1 1/2
NESPT-3P	3" Tapered	5/8 - 3/8





KRYLON® INDUSTRIAL PAINTS
Acrylic Enamel Spray Paint
Tough Coat™



- Specially formulated for a variety of industrial applications; tough, protective coating resists chipping and peeling
- Ideal for light-to heavy-duty painting projects, both indoors and outdoors
- Smooth, even coverage with fan spray nozzle
- Fast-drying; dries to the touch in just 15 minutes
- Size: 16 oz. can, 12 oz. net, 12/case

Item #	Color
KRS00326	Machinery Lt. Gray
KRS00329	Machinery Blue Gray
KRS00325	Machinery Dark Gray
KRS01000	Clear Gloss Topcoat
KRS01003	Intl. Harvester Red
KRS01005	Bright Red
KRS01006	Allis Chalmers Orange
KRS01008	Ford Blue
KRS01101	Cherry Red
KRS01110	OSHA Red
KRS01150	Zinger Pink
KRS01210	OSHA Orange
KRS01285	Cordova Brown
KRS01305	Lt. Beige
KRS01310	OSHA Yellow
KRS01415	Machine Green
KRS01470	OSHA Safety Green
KRS01485	Ivy Green
KRS01510	OSHA Blue
KRS01515	Dark Blue
KRS01540	Light Blue
KRS01580	OSHA Purple
KRS01760	Aluminum
KRS01765	Gold
KRS01770	OSHA Black
KRS01800	OSHA White
KRS03720	Flat White
KRS03725	Semi-Flat Black
KRS03727	Max Flat Black
KRS01811	Orange
KRS01812	Red
KRS01815	Green
KRS00324	Aluminum
KRS00332	Black
KRS00339	Red Oxide
KRS00340	Gray
KRS00341	Light Gray Sandable
KRS00342	Red Oxide Sandable



SPRAYON®
Silver Galvanizing Compound



Shiny Finish

- Bright hot-dip shiny finish
- Excellent touch-up for repair of galvanized substrates
- Inhibits corrosion on ferrous metals
- 69% zinc
- Dries to touch in 30 minutes
- VOC compliant
- Meets ASTM A780
- Size: 16 oz. can, 14.25 oz. net, 12/case

Item #
KRS00739

SPRAYON®
Zinc-Rich Cold Galvanizing Compound



Dull Finish

- Provides maximum protection to steel exposed to severe corrosive environments
- Fuses zinc to the metal substrate to protect against corrosion
- 97-percent pure zinc dust, low VOC
- Excellent anti-sag and anti-settling properties
- May be topcoated with conventional primers or finish coats
- Highly resistant to salt corrosion and water
- Meets or exceeds performance requirements to MIL-P-26915C
- Outstanding weld through primer
- Size: 16 oz. can, 14 oz. net, 12/case

Item #
KRS00740



KRYLON® INDUSTRIAL PAINTS
Inverted Marking Paint
Quik-Mark™



- High solids formation for bold, bright, visible markings
- Fast drying
- Penetrates and adheres to hot surfaces
- Convenient Spray Thru™ cap and non-clogging spray tip
- VOC Compliant, free of lead hazards
- Size: 20 oz. can, 17 oz. net, 12/case

Item #	Color
--------	-------

Water Based Marking Paints

KRS03500	Clear
KRS03620	Caution Blue
KRS03901	Brilliant White
KRS03911	Brilliant Red

Flourescent, Water Based

KRS03612	Pink
KRS03630	Safety Green
KRS03700	Orange

Solvent Based Marking Paint

KRS03600	Clear
KRS03611	A.P.W.A. Red
KRS03621	A.P.W.A. Blue
KRS03631	Green
KRS03821	High Visibility Yellow
KRS03900	Utility White

Flourescent, Solvent Based

KRS03613	Safety Red
KRS03614	Neon Green
KRS03622	Hot Pink
KRS03701	Red Orange
KRS03702	Orange

KRYLON®
Line-UP® Striping
Machines and Wand



- Engineered and designed for easy operation and durability
- Machines constructed of 18-gauge steel
- Machine have 12 can storage capability
- Stripes widths of 2" to 4"
- K08340 has 7" wheels for a smooth ride on hard surfaces, such as concrete, blacktop and metal
- K08350 has 10" wheels whiche elevate the carriage to provide an even ride over rough or uneven surfaces, such as grass, dirt or gravel
- K08360 has 34" long handle for ease of use, ideal for stenciling or line touch-ups

Item #	Description
KRK08340	Pavement Striping Machine
KRK08350	Athletic Field Striping Machine
KRK08360	Striping Wand

KRYLON® INDUSTRIAL PAINTS
Solvent Based Pavement
Striping Paint

Line-Up® Solvent-Based Pavement Striping Spray Paint is a fast-drying product that provides long-lasting durability on outdoor pavement, as well as on indoor surfaces.



- VOC compliant
- Free of lead hazards
- Non-clogging and fast-drying
- 20oz. can (18 oz. net)

Item #	Color
KRK08300	Highway White
KRK08301	Highway Yellow

KRYLON® INDUSTRIAL PAINTS
Water Base Athletic Field
Striping Paint
Line-Up®

Line-Up® Water-Based Athletic Field Striping Spray Paint is ideal for striping grass fields or for other short-term striping projects. These water-based products are available in many popular athletic colors and feature non-clogging spray tips.



- VOC compliant
- Free of lead hazards
- Fast-drying
- 20oz. can (18 oz. net)

Item #	Color
KRK08305	Athletic White
KRK08306	Athletic Yellow



KRYLON®
**Wheeler Hand Held
Marking Wand**

- For marking pavement, concrete, asphalt, gravel, soil or grass
- Constructed of durable, rugged plastic and lightweight steel
- 34" long
- Comfortable pistol grip for easy handling & marking
- Applies a uniform width of paint: 1" to 1-1/2"
- Use with Upside Down Marking Paint



Item #	Description
KRK07096	Wheeler Wand 34"
KRK07095	Hand Held 12"



SPRAYON®
Safety Solvent & Degreaser

- Fast-acting solvent penetrates easily, evaporates quickly, leaves no residue
- Excellent cleaning properties make it ideal for removing grease, dirt, wax and metallic particles prevalent in most industrial plants
- Non-conductive, non-flammable
- Authorized by USDA, K-2 Rated
- Dielectric strength: 37,000 volts
- Includes extension tube & high delivery nozzle
- Size: 20-oz. can, 17 oz. net, 12/case
- Compare to CRC 03095



Item #
KRS20848

SPRAYON®
General Purpose Cleaner

- All-purpose formula that cuts through dirt with ease
- Effective and safe to use on metal, finished wood, porcelain, vinyl, leather, laminated surfaces and glass
- Cleans spots on synthetic carpets
- Authorized by USDA, C-1 Rated
- Size 20 oz. can, 19 oz. net, 12/case



Item #
KRS00880

SPRAYON®
**Electrical Cleaner
& Lubricating Spray**
Sprayon®

- Makes high precision electrical equipment like new
- New non-ozone depleting formula
- Cleans & penetrates surface pores; leaves a fine microscopic corrosion-proof film
- Removes contaminants such as grease, dirt, dust and oxidation residue; eliminates related humming noise
- NSF reg. no 115081; K2 rated
- Dielectric strength 36,700 volts
- Includes extension tube
- Size 16 oz. can, 16 oz. net, 12/case



Item #
KRS02001

SPRAYON®
Cutting Oil

- Extends tool life, reducing tool sharpening and downtime
- Recommended for all metals, including stainless steel and soft metals such as aluminum, brass and copper
- Clings to surface
- Jet-spray allows precision applications
- USDA H-2 rated
- Includes extra actuator with extension tube
- Size: 16 oz. can, 12 oz. net, 12/case



Item #
KRS00208

SPRAYON®
Wasp and Hornet Killer
Blast'Em™

- Kills wasps, hornets, yellow jackets, flies, mosquitoes and flying moths
- Residual deposit will kill returning wasps and hornets
- Contains a high amount of petroleum distillates for the best knockdown and kill rate
- Will not harm most plastics, including Noryl, ABS and Lexan
- 98% knockdown, 100% kill within 24 hours
- Dielectric strength: 33,000 Volts
- Sprays up to 20 feet with flood-type valve
- EPA-Registered



Item #	Size (oz.)
KRS00857	16
KRS20857	20



WHITE LIGHTNING® CAULKS & SEALANTS

Expanding Insulating Foams

Stop Gap!™

- Expand to fill cracks and gaps forming an airtight and waterproof bond
- Cures in 8 hours
- Can be applied at temperatures between 60°F and 100°F
- Cured product hardens and can be trimmed, shaped, sanded, painted, or stained
- Size: 16 oz. can, 12 oz. net, 8/case



Minimal Expanding Foam:

- Can be used to seal and insulate around windows and door frames
- Dries tack free in 15 minutes
- Great for use on wood, masonry, metal, glass, and most plastics

Triple Expanding Foam:

- Dries tack free in 30 minutes
- Great for use on openings and gaps at plate line, masonry, corner and T-joints, exterior sheeting, and concrete or wood walls

Item #	Type
KRWL1111100	Minimal Expanding
KRWL3333300	Triple Expanding



TRI-FLOW®

Tri-Flow® Superior Lubricant

- A superior, light viscosity lube that allows for deep penetration into hard to reach moving parts
- The trigger action spray allows you to blast into areas that need lubrication
- High-grade petroleum oils provide optimum lubrication under extreme temperatures (-60 to 475°F) and humidity
- Formulated solvents soften and remove dirt and contaminants, while special additives displace moisture and prevent rust and corrosion
- Formulated with P.T.F.E.



Item #	Size
KRTF20027	.25 oz. Pin Point
KRTF20009	4 oz. Aerosol Can
KRTF29200	18 oz. Trigger Spray Bottle



3M FIRE PROTECTION PRODUCTS

Multipurpose Spray Adhesives

Super 77™

- High tack, high coverage, and fast drying
- Permanently attaches foils, carpeting, lightweight foams, paper, cardboard, felt, and cloth to painted or unpainted metals, wood, and cardboard
- 24 oz. can



Item #
3M77



WHITE LIGHTNING® CAULKS & SEALANTS

Multi purpose Spray Adhesive

Multi-Purpose Industrial aerosol adhesive is great for bonding a variety of lightweight materials. Provides high coverage and has low soak in factor. For long lasting, secure bonds whether your project is simple or complex.

- Recommended Uses: Lightweight foams, paper, cardboard, cartons, fabric, carpets, plastic, metal, wood, fiberglass, foil, felt, unpainted metals, cloth
- Forms bonds and tacks instantly
- Dries quickly
- Controlled mist spray pattern
- VOC & MIR compliant
- Tack Range: 10-30 seconds
- 24 oz. can (16.5 oz. net)



Item #
KRWL070000

WHITE LIGHTNING® CAULKS & SEALANTS

Industrial Spray Adhesive

White Lightning® Heavy Duty Industrial aerosol adhesive can be used to bond laminates, plastic, cardboard, metal, ceramics, particle board, paper and wood.

- Bonds heavy-duty substrates
- High strength
- Heat resistant up to 170° f.
- Controlled lace spray pattern
- VOC & MIR compliant
- Tack Range: 10-30 seconds
- 24oz. (16.5 oz. net)



Item #
KRWL0090000



SPRAYON®
All purpose Lubricant
LU™ 711 The Protector™



- An ultra-thin, transparent blend of high-quality petroleum distillates
- Specifically formulated to ensure maximum moisture displacement
- Its film resists the collection of abrasive particles on delicate contacts and connectors
- Forms a continuous film that spreads evenly over metal surfaces, giving uniform protection against corrosion attack
- This 'spreadability' also makes it an excellent penetrant for freeing corroded parts and mechanisms
- Will not affect plastic, rubber, fabrics or painted surfaces.
- Size: 16 oz., 11 oz. net, 12 per case
- Compares to WD40

Item #
KRS00711

SPRAYON®
Penetrant
Rust Breaker™



- A fast-acting product that quickly loosens rust while penetrating grease and dirt
- A transparent, non staining oil, its light film displaces moisture and acts as a corrosion preventative
- Jet stream sprays up to two feet for safe, accurate application
- It is a one coat rust and corrosion preventive compound. Pleasant vanilla scent.
- Size: 16 oz., 12 oz. net, 12 per case
- Compares to CRC 03060

Item #
KRS00103



PASLODE
Cordless Tool Cleaner



- Powerful spray removes dirt, moisture and oxides without residue
- Safe for Internal Electronic Components
- Cleans and Dries Quickly
- Non-CFC, Plastic Safe
- Available in 12 oz. cans

Item #
PA219348



CRC INDUSTRIES
Contact Cleaners
QD™



A petroleum distillate and alcohol blended precision cleaner suitable for sensitive electronics and electrical equipment. Evaporates quickly, leaves no residue and is safe to use on all plastics. It contains no Class I or Class II ozone depleting chemicals.

- Effectively removes soil and other contaminants from electrical and electronic components
- Ideal for applications where lower flashpoint solvents can be used
- Size: 16 oz., 11 oz. net
- Units per case: 12

Item #
CRC03130

CRC INDUSTRIES
Super Penetrants
Screwloose®



Quickly penetrates through rust and corrosion to rapidly free corroded bolts, screws, fasteners, pins and bound mechanisms

- Facilitates fast and easy disassembly of mechanical components, fittings, assemblies and other fasteners
- Clear formula contains no dyes and leaves no mess
- NSF H2 registered for use in meat and poultry plants
- Size 16 oz., 11 oz. net
- Units per case: 12

Item #
CRC03060

CRC INDUSTRIES
Heavy-Duty Degreaser



Quickly and effectively removes grease, oil, tar, adhesives, dirt, grime, corrosion, sludge and other stubborn substances to increase operating efficiency of equipment. Offers quick and efficient degreasing action and fast evaporation with no residue. Use caution on plastics.

- No flash or fire point
- Non-corrosive and non-staining
- High dielectric strength of 36,700 volts
- Size: 20 oz., 19 oz. net
- Units per case: 12

Item #
CRC03095



CRC INDUSTRIES
**Multi-Purpose Lubricant
 and Corrosion Inhibitor**
3-36®

- Multi-puroose lubricant, penetrant and corrosion inhibitor displaces and seals out moisture with a micro-thin continuous film
- Penetrates through corrosion, loosening frozen parts
- Lubricates surfaces without leaving a sticky residue
- Cleans light soils from surfaces, leaving a corrosion-resistant barrier
- USDA authorized for use in federally inspected meat and poultry plants
- Equipped with the 360° Spray Valve for added convenience
- Size: 16 oz., 11 oz. net
- Units per case: 12



Item #
 CRC03005



KIMBERLY-CLARK
Reinforced Wipers
Wypall® X60

- Set a higher standard for general purpose wipers
- No adhesives or binders; leaves nothing behind
- Re-inforced for extra scrubbing and cleaning power
- Tough enough for big jobs -- soft enough for face and hands
- White color
- Size: 12.5"x16.8"
- 180 per Brag™ Box



Item #
 KC34015

KIMBERLY-CLARK
Waterless Hand Wipes
WYPALL®

- Pre-moistened wipes with a heavy-duty waterless cleanser
- Green in color
- Orange Citrus Fragrance
- Size: 10-1/2" X 12-1/4"
- 75 per bucket



Item #
 KC91371

KIMBERLY-CLARK
Pre-Saturated Wipes
KIMTECH PURE®

- Made of 100% polypropylene
- Contains 70% isopropyl alcohol and deionized water
- Recommended for ISO Class 4 or higher cleanroom environments
- 9" x 11" white multi fold
- 40 per re-sealable pouch



Item #
 KC06070

Waterless Hand Cleaner
Gojo® Lemon

Advanced cleaning formula, Lemon Creme cleans with or without water. Safe to use, it does not contain harsh solvents. Formulated with Vitamin E, lanolin and aloe. Won't clog drains. Pumice cleaner, with scrubbing particles, is very effective removing difficult grease and grime such as paint, putty, and resin glue.

- Size: 4.5 lb. plastic cartridge



Item #
 GJ0915-06

Hand Cleaner
Gojo® Natural Orange™

- Contains pumice scrubbing particles
- Removes grease, tar and oil
- Natural citrus ingredients, leaves pleasant scent
- Quick-acting lotion formula



Item #	Size
GJ0950-24	4 oz. bottle
GJ0955-04	1 gal. pump

WD-40

WD-40 CO.

Spray Applicator

- Empty plastic spray applicator



Item #

WD10100

WD-40 CO.

Penetrating Lubricant

- Finds squeaks and lubricates them in hard-to-reach mechanisms
- Silicone-free, no residue
- Protects metal surfaces with corrosion-resistant ingredients to shield against moisture and other corrosive elements
- Loosens rust-to-metal bonds and frees stuck, frozen or rusted metal parts
- Displaces moisture
- New "Smart Straw" is integrated in to the spray valve



Item # Desc.

WD110108	3 oz.
WD110054	8 oz.
WD110078	11 oz.
WD10110	Gallon

Call Edge for help with:

- **LEED Points**
- **MSDS Sheets**
- **Safety Yellow Paint**
- **VOC Contents**
- **Shelf Life**
- **Other Paint Products**
- **Other Cleaners**
- **Other Degreasers**

**We can special order
many kinds of bulk
paints & chemicals!**



ALLIED TUBE & CONDUIT

Telescoping Square Tubing

Telespar



- Holes on 1" center in telescoped sections remain in perfect alignment
- Holes are 7/16" diameter
- Hole patterns on 1, 2, or 3 sides may be special ordered to meet your specific needs
- Sections without holes and Qwik-Punch® sections are available
- Typically, available in 10, 12, and 14 gauge steel, standard lengths are 20 and 24 feet
- Edge can cut or quote other lengths to meet your project needs
- Certificates of conformance and material origins will be available if requested
- Ask for drawings and specifications of our products to meet your highway and DOT needs
- One of the secrets of Telespar's versatility is its ability to telescope, smaller sizes fit smoothly and snugly into the next larger size
- Standard finish is pre-galvanized, inquire about Perma-Green or plain finishes

Item #	Tube Size (in.)	Gauge	Length (ft.)	Wt. (lbs.)
UT14F12PG	1½	12	24	42.1
UT16D12PG	1¾	14	24	41.3
UT16F12PG	1¾	12	24	50.6
UT16F12PG-20'	1¾	12	20	42.2
UT20D12PG-10'	2	14	10	19.9
UT20D12PG-12'	2	14	12	23.9
UT20D12PG	2	14	24	48.0
UT20F12PG	2	12	24	59.0
UT20F12PG-8'	2	12	8	19.6
UT20F12PG-10'	2	12	10	24.6
UT20F12PG-12'	2	12	12	29.5
UT20F12PG-14'	2	12	14	34.2
UT20F12PG-20'	2	12	20	49.2
UT21H12PG	2¾	10	24	83.3
UT22F12PG	2¼	12	24	67.5
UT22F12PG-30"	2¼	12	2.5	7.0
UT24F12PG	2½	12	24	75.9
UT24F12PG-10'	2½	12	10	31.4
UT24H12PG	2½	10	24	91.8

Qwik Punch

UT16D12-24-QP	1¾	14	24	45.4
UT20D12-20-QP	2	14	20	43.6
UT20D12-24-QP	2	14	24	42.3

Heavy-Duty Anchor

Telespar

2-1/2" Heavy-Duty Anchors:

- For permanent 2" sq. Telespar installation
- 2-1/2" will also receive SB8-200250B-G Slip Base (same as old part number UT25K12A3)

3" Heavy Duty Anchors:

- For permanent 2-1/2" x 12 ga. sq. Telespar installations
- 3" will also receive SB8-250300B-G Slip Base (same as old part number UT30K12A3)



Item #	Length (in.)	Gauge	Wt. ea. (lbs.)
2½"			
UTHDA200-30-G	30	7	13.85
UTHDA200-36-G	36	7	16.63
UTHDA200-42-G	42	7	19.39
UTHDA200-48-G	48	7	22.17
3"			
UTHDA250-18-G	18	7	10.05
UTHDA250-30-G	30	7	17.22
UTHDA250-36-G	36	7	20.6
UTHDA250-42-G	42	7	24.19
UTHDA250-48-G	48	7	27.48

Heavy-Duty Anchor

Winged

Telespar

2-1/2":

- For permanent 2" Sq. Telespar Installation
- Will also receive SB8-200250B-G Slip Base

3":

- For permanent 2-1/2" x 12 ga. Sq. Telespar Installations
- Will also receive SB8/250300B-G Slip Base



Item #	Anchor Size (in.)	Wt. Ea. (lbs.)
2½"		
UTTWA200-36-G	2½x36	28.71
UTTWA200-42-G	2½x42	31.15
UTTWA200-48-G	2½x48	34.55
3"		
UTTWA250-36-G	3x36	35.00
UTTWA250-42-G	3x42	39.30
UTTWA250-48-G	3x48	43.08



Heavy-Duty Anchor

Slip Base Bottom Telespar



- For concrete installation, FHWA accepted
- Concrete footing recommendation (12" x 30" standard soil)
- FHWA Approved in weak soil with an 18" x 42" concrete footing

Item #	Anchor Size (in.)	Wt. Ea. (lbs.)
--------	-------------------	----------------

8" Slip Base Bottom/Anchor

UTSB8-CTA30-G	3x30	22.75
UTSB8-CTA36-G	3x36	26.43
UTSB8-CTA42-G	3x42	30.11
UTSB8-CTA48-G	3x48	33.79

9" Slip Base Bottom/Anchor

UTSB9-CTA30-G	3x30	24.38
UTSB9-CTA36-G	3x36	28.06
UTSB9-CTA42-G	3x42	31.73
UTSB9-CTA48-G	3x48	35.41

10" Slip Base Bottom/Anchor

UTSB10-CTA30-G	3x30	27.01
UTSB10-CTA36-G	3x36	30.69
UTSB10-CTA42-G	3x42	34.36
UTSB10-CTA48-G	3x48	38.04

Slip Base Top

Telespar

- NCHRP 350 Compliant/FHWA Letter SS-134 (A)



Item #	Desc.	Wt. Ea. (lbs.)
UTSB8C-250A-G	Cast Iron 8" Triangular Top, Receives 2 1/2" Square Post. Includes Post Locking Wedge (LWX35-G)	10.25
UTSB10C-250A-G	Cast Iron 10" Triangular Top, Receives 2 1/2" Square Post. Includes Post Locking Wedge (LWX35-G)	12.5
UTRTSB-MPHDW	Universal Redi-Torque Match Plate Hardware Kit For Triangular Slip Bases	1.50

Slip Base

Top & Bottom Telespar



Item #	Fits	Desc.	Wt. Ea. (lbs.)
--------	------	-------	----------------

Top Half Post Receivers

UTSB8-250TA-G	2 1/2" O.D. Sq. Post	8" Triangular Slip Base Top Half for 2 1/2" Square Post	9.50
UTSB9-250TA-G	2 1/2" O.D. Sq. Post	9" Triangular Slip Base Top Half for 2 1/2" Square Post	10.70
UTSB10-250TA-G	2 1/2" O.D. Sq. Post	10" Triangular Slip Base Top Half for 2 1/2" Square Post	12.90
UTSB10-300A-G	3" O.D. Sq. Post	10" Triangular Slip Base Top Half For 3" Square Post	17.55

Bottom Half To Fit Heavy-Duty Anchors

UTSB8-250300B-G	3"x7ga. Anchor	9" Triangular Slip Base Bottom Half	11.20
UTSB9-250300B-G	3"x7ga. Anchor	8" Triangular Slip Base Bottom Half	12.92
UTSB10-250300B-G	3"x7ga. Anchor	10" Triangular Slip Base Bottom Half	14.10

Slip Base

Kleen Break Model 425 Sign Post Coupler Assemblies

Telespar

- NCHRP 350 Compliant/FHWA Letter SS-131



Item #	Desc.	Wt. Ea. (lbs.)
UTXKBSM42520-G	Surface Mount Kleen Break Assembly	14.43
UTXKB42520-G	Complete Kleen Break Assembly for 1 3/4" & 2" Square Post	12.2

Telespar Hardware

5/16" Corner Bolt Telespar



Item #	Length (in.)	Wt/100 pcs. (lbs.)
UTCB516-S-Z	2	4.4
UTCB516-M-Z	2½	5.23
UTCB516-L-Z	3	6.12

Telespar Hardware

Telespar

- Small Box Quantities - 100 or 250 pc. boxes



Item #	Desc.	Weight per 100 Pcs. (lbs.)
UTDRAS3878-06	3/8" Aluminum Shell/Steel Pin Drive Rivet	2.25
UTDRAS3878-06-W	3/8" Aluminum Shell/Steel Pin Drive Rivet w/ Washer	2.35
UTXDR3878-05-Z	3/8" All Steel Econo Drive Rivet	4.28
UTNW38	3/8" Nylon Washer	0.06

Connector Bracket

Telespar

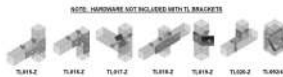

*Hardware not included with TL Brackets.

Item #	Desc.	Wt. Ea. (lbs.)	Std. Pkg.
UTTL015-Z	T-Fitting	.50	25 ea./box
UTTL016-Z	L-Fitting	.63	25 ea./box
UTTL017-Z	Anti-Rotation Fitting	.33	25 ea./box
UTTL018-Z	Straight Fitting	.84	25 ea./box
UTTL019-Z	45 Degree Off-set Fitting	.44	25 ea./box
UTTL020-Z	90 Degree Fitting	.26	25 ea./box
UTTL092-Z	3/8" Gravity Lock Pin Through 2"	.26	25 ea./box
UTTL094-Z	3/8" Gravity Lock Pin Through 2½"	.29	25 ea./box

Cast Aluminum Caps & Crosses

Telespar



Item #	Desc.	Wt. Ea. (lbs.)
UTARC175	Pyramid Rain Cap 1¾" Telespar	.18
UTARC200	Pyramid Rain Cap 2" Telespar	.20
UT850FL175C	Flat Blade, 1¾" Telespar Bracket	.77
UT850XL175C	Extruded Blade, 1¾" Telespar Bracket	.85
UT850FL200C	Flat Blade, 2" Telespar Bracket	.68
UT850XL200C	Extruded Blade, 2" Telespar Bracket	.78
UT850FL90X	Flat Blade, 90° Cross Bracket	.59
UT850XL90X	Extruded Blade, 90° Cross Bracket	.66
UT850FL45X	Flat Blade, 45° Cross Bracket	.59
UT850XL45X	Extruded Blade, 45° Cross Bracket	.66
UT808FL238C	Flat Blade, 2¾" RD. Bracket	.65
UT808XL238C	Extruded Blade, 2¾" RD. Bracket	.71

Type III Barricade Brackets

Telespar

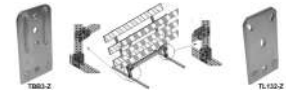

Item #	Desc.	Wt. Ea. (lbs.)	Std. Pkg.
UTTBB3-Z	Collapsible Barricade Plate, Fits All Telespar	.9	20 ea./box
UTTBB3A-Z	Collapsible Barricade Assembly, Fits All Telespar	2.25	10 sets/box
UTTL132-Z	Shear Pin Barricade Plate, Fits 1¾" & 2" Telespar	1	20 ea./box
UTTL133-Z	Shear Pin Barricade Assembly, Fits 1¾" & 2" Telespar	2.4	10 sets/box



Barricade Repair Hardware

Telespar



Item #	Desc.	Weight per 100 Pcs. (lbs.)
UTHHSB25-300N-Z	1/4" x 3" Hex Head Shear Bolt w/ Nut	5.72
UTG8FB38-30N-Z	3/8" x 3" Gr. 8 Flange Bolt w/ Nut	13.27

Gas Powered Drive Hammer

Telespar



- Atlas Copco Cobra Combi gas powered drill/breaker
- Includes:
 - Replacement plug and starter rope, 1 liter oil, 1-3/8" drill steel x 16" length, 1-3/4" wide chisel x 13-1/2" length, carrying case & owners spare parts & safety manuals
 - Chuck fits standard 7/8" x 4-1/4" hex detachable shanks

Item #
UTCC-78414

Lock and Release Power Drive Caps

Telespar



- To be used with Lock and Release Power Drive Shanks

Item #	Type	Guide Size (in.)	Fits Anchor Size	Wt. (lbs.)
UTDC150175LR	Square	1 1/2	1 3/4" x 12 ga.	3.74
UTDC175200LR	Square	1 3/4	2" x 12 ga.	4.24
UTDC200225LR	Square	2	2 1/4" x 12 ga.	4.86
UTDC219250LR	Square	2 3/16	2 1/2" x 10 ga.	6.40
UTDC225250LR	Square	2 1/4	2 1/2" x 12 ga.	6.57
UTDC250300LR	Square	2 1/2	3" x 7 ga.	8.03

Ask an Edge sales representative about other Telespar products and accessories.

Lock and Release Power Drive Shanks

Telespar



- To be used with Lock and Release Power Drive Caps
- Proper shank size determined from two measurements:
 - (A) Hex diameter across two opposite flats
 - (B) Hex length from locking collar to top of hex

Item #	Hex Size (A) x (B) (in.)	Wt. (lbs.)
UTDS4875LR	7/8 x 3 1/4	2.70
UTDS61250LR	1 1/4 x 6	5.6

The versatility of 3 fastening options

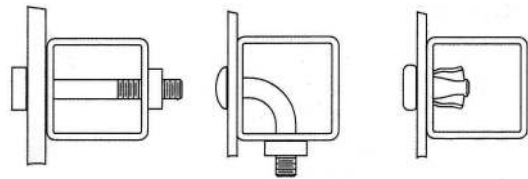

Basic Ground Support Options

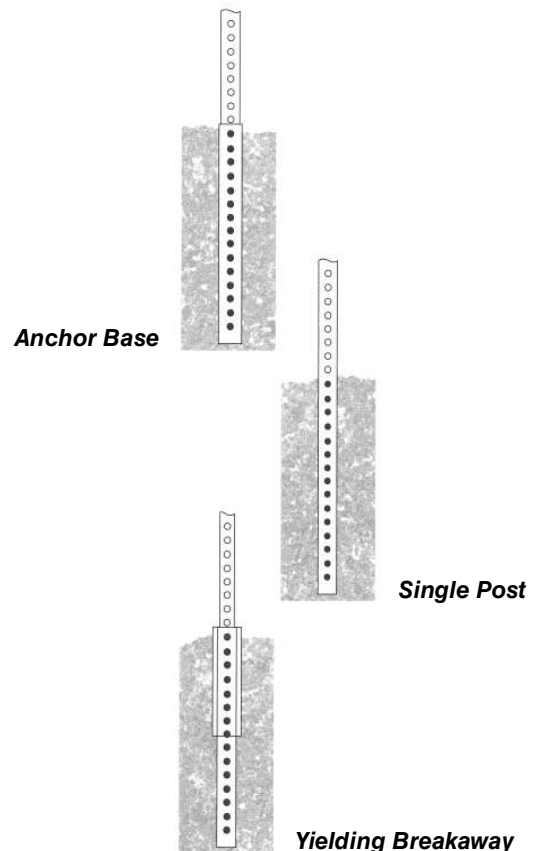

Visqueen Sheeting

- Poly America Visqueen, Polyethylene Sheeting



Item #	Size (ft.)	Thickness (mil)	Color
PO212C	12x200	2	Clear
PO406C	6x100	4	Clear
PO408C	8x100	4	Clear
PO410B	10x100	4	Black
PO410C	10x100	4	Clear
PO420B	20x100	4	Black
PO420C	20x100	4	Clear
PO610C	10x100	6	Clear
PO620B	20x100	6	Black
PO620C	20x100	6	Clear
PO620W	20x100	6	White

Flame Retardant

PO420FR	20x100	4	White
PO620FR	20x100	6	White



RAVEN INDUSTRIES Reinforced Enclosure Films Dura-Skrim™



- Constructed with a high strength polyethylene film and heavy-duty scrim reinforcement, laminated together with a layer of molten polyethylene
- Generous amount of reinforcement in our string reinforced poly, string pattern is uniform and offers tear resistance in both machine and transverse directions
- Sheeting that resists puncturing and responds to tears immediately by surrounding and stopping the tear
- 6 mil thickness

Item #	Size (ft.)
RNR5CC20100	20x100
RNR5CC40100	40x100
RNR5CC20100FR	20x100 Fire Retardant

**** Special sizes available upon request ****

RAVEN INDUSTRIES

Underslab Vapor Retarder/Barrier VaporBlock™

- VaporBlock™ is a high performance underslab vapor retarder designed to retard moisture migration through concrete slabs-on-grade
- This products is made from state-of-the-art polyethylene resins that provide superior physical and performance properties that far exceed ASTM E-1745 (Plastic Water Vapor Retarders Used in Contact with Soil or Granular Fill Under Concrete Slabs) Class A, B, and C requirements
- High tensile strength, unequaled puncture resistance, low moisture vapor permeability as well as resistance to decay
- Impedes the transmission of water vapor from traveling upward through a concrete slab-on-grade or through a concrete wall when properly installed, it is extremely important to avoid puncturing a vapor retarder during installation to assure proper performance
- Protect your flooring and other moisture sensitive furnishings in your building's interior from moisture migration
- Can also greatly reduce condensation, mold and degradation by controlling water vapor migration
- Blue is the standard color option for VaporBlock™
- All rolls are folded and rolled on heavy-duty cores for ease in handling and installation
- Installation instructions and ASTM E-1745 classifications accompany each roll



Item #	Thickness (mil)	Size (ft.)	Classification	Tensile Strength (New Material) (lbs/in)	Tensile Strength (After Exposure) (lbs/in)	Puncture Resistance (g)	Max Use Temp (°F)	Min Use Temp (°F)	Permeance
RNVB10	10	15x200	Class A, B, & C	52	53	2,600	180	-70	.0146
RNVB15	15	12x200	Class A, B, & C	88	82	4,000	180	-70	.009

Call Edge to provide specifications on Vapor Barrier to meet your entire project needs.



RAVEN INDUSTRIES
Underslab Vapor Retarder Seam Tape
VaporBlock™



- White single-sided tape combines a heavy-duty, weather-resistant polyethylene backing with an aggressive rubber adhesive
- Typical applications include vapor retarders, covers and liners

Item #	Size (ft.)
RNVAPOR BOND	4 x 210 roll

Poly Tarps



- Woven polyethylene with coating on both sides
- All edges roped and fully hemmed
- Rust-free grommets every three feet
- 8x8 scrim, 70 gram per square meter

Item #	Size (ft.)
TWT0608	6X8
TWT0810	8X10
TWT1012	10X12
TWT1216	12X16
TWT1220	12X20
TWT1620	16X20
TWT2030	20X30
TWT2040	20X40



THE WIND CLIP COMPANY
Scaffold Wind Clip

- Used to securely fasten plastic to scaffolding

Item #
WC

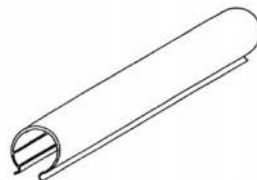

SURFACE SHIELDS
Carpet Shield®



- Clear, self-adhering protective film for all types of carpeting
- Uniquely formulated adhesive system adheres to all carpet substrates
- Special blend of polyethylene is highly resistant to tears or punctures
- Reverse wound for easy application
- Great protection during remodeling, painting, moving, model home tours and parties

Item #	Desc.
SFCS24200W	24"x 200' Reverse Wound
SFCS36200W	36"x 200' Reverse Wound
SFCS36500	36"x 500' Reverse Wound

Accessories

SFA2436	Applicator for 24" & 36" rolls
---------	--------------------------------

SURFACE SHIELDS
Floor Shield™



- Self-adhering protective film for hard surfaces, tile, vinyl, VCT, laminates, marble, granite, and factory-finished hardwood
- Ideal for use during construction, remodeling, plumbing and electrical work and painting
- Reduces damage claims and clean up time, resists ripping and tearing
- Does not shift like paper and it applies and removes easily

Item #	Desc.
SFFS24200	24"x 200' Reverse Wound

SURFACE SHIELDS
Kraft Paper

- Preferred alternative to "Red Resin" paper
- Construction grade - 100% recyclable
- Protects floors, cabinets and counter tops from traffic, paints and spills
- Natural color

Item #	Desc.
SFKP35166	36"x 166' Roll





SURFACE SHIELDS **Water Shield**

- Non-staining, water resistant
- Made from a lamination of two strong kraft papers with nylon scrim reinforcement
- Does not tear under normal traffic wear and protects flooring surfaces like hardwood, laminate and tile
- Natural color



Item #	Desc.
SFWS36300	36"x 300' Roll
SFWS60300	60"x 300' Roll

SURFACE SHIELDS **Pro Shield**

- All purpose hard surface protection
- Absorbs many times its own weight in liquids
- Leak-proof backing
- Slip-resistant, lightweight and flexible
- Keep job site floors and carpets safe from damage and debris



Item #	Desc.
SFPS3250	32"x 50' Roll

SURFACE SHIELDS **Zip n Close® Zipper**

- Creates instant access to tarps or plastics
- Pressure sensitive adhesive backing
- Used to control dust and heat loss
- Can be operated from either side
- Use 1 for a flap and 2 for wider opening
- Color: Red



Item #	Desc.
SFZA02	1.5"x 7' (2 per pack)

SURFACE SHIELDS **Slip-on Shoe Covers**

- Protect floors from dirt, scuffs, and heel marks
- Easy to use shoe covers are perfect for general construction work, open houses, as well as during inspections
- Lightweight and disposable; one size fits all



Item #	Desc.
SFSC300	Blue Slip-on
SFSC300WR	Skid-resistant, White

SURFACE SHIELDS **Clean Mat**

- Polyethylene film mat with a tacky surface that removes dust and dirt from footwear
- Each mat contains 30 sheets which are tabbed for easy removal of each layer
- Clean mat stays firmly in place and is easy to use and dispose of
- Does not adhere to carpeted surfaces



Item #	Size (in.)	Color
SFCM2436	24 x 36	White
SFCM2436BLUE	24 x 36	Blue
SFCM3636	36 x 36	White
SFCM3636BLUE	36 x 36	Blue

SURFACE SHIELDS **Dirt Grabber Clean Mat**

- Polyethylene film mat with a tacky surface that removes dust and dirt from footwear
- Each mat contains 30 sheets which are tabbed for easy removal of each layer
- Sturdy re-usable surface; non-skid backing help secure to floors
- Does not adhere to carpeted surfaces



Item #	Desc.
SFDG30W	25.5"x 31.5" White On Black Frame

Refill

SFDGRC	30 Layer
--------	----------

SURFACE SHIELDS **Moving Protection Sleds**

- Easily moves heavy objects across carpeting
- Non-slip foam rubber top to pad heavy objects
- Extra smooth flexible bottom; sturdy, unbreakable construction



Item #	Desc.
SFAP1	1' Sled (Pack Contains 4 Sleds)
SFAP4	4' Sled (Pack Contains 2 Sleds)
SFAP6	6' Sled (Pack Contains 2 Sleds)

Accessories

SFAPH	Handles (Pack Contains 4 Handles)
-------	-----------------------------------

SURFACE SHIELDS **Plan Shield**

- Clear, water resistant protection for architectural and important documents
- Made of an 8 mil thick durable vinyl
- Use for storage or protection on the job site, resealable



Item #	Size (in.)
SFPC3042	30 x 42
SFPC3648	36 x 48



SURFACE SHIELDS

Blue Multi Purpose Tape

- Holds sheet vinyl, carpet pads, hardwood or laminate in place
- Has outstanding durability; can be used indoors or outdoors
- Offers 14 day UV protection; removes cleanly up to 14 days after application



Item #	Desc.
SFBT2180	2" x 180' Roll

SURFACE SHIELDS

Duct Cover Shield

- Self-adhering protective film has a high adhesion suitable for all types of duct work
- The water-based adhesive will not leave a residue on the metal after removal
- Special blend of polyethylene is highly resistant to tears or punctures
- Satisfy SMACNA guidelines during construction by providing temporary closures on open ductwork



Item #	Size (in. x ft.)	Color
SFDC24200	24 x 200	Clear
SFDC36200	36 x 200	Clear
SFDC48200	48 x 200	Clear

SURFACE SHIELDS

Builder Board

- 100% recyclable - at least 33% post consumer
- Heavy-duty, reusable temporary floor protection
- Less expensive and 1/3 the weight of 1/8" masonite
- Tough enough to be driven on - approx. 48 mil. thick



Item #	Desc.
SFBLD38100	38"x 100' Roll

**Economically
protect your floors
so they don't need
to be re-finished!**



ZIPWALL, LLC

ZipWall® Carrying Bag

- Made of tough polyester
- Keeps all your barrier products organized and easy to transport
- Holds the 20 foot pole and the red jack unattached



Item #
ZWCARRYBAG

ZIPWALL, LLC

ZipWall® Foam Rail Kit

- An SLP™ or Kit 20 pole is required for each Foam Rail™ cross bar (poles are not included in the FR2)
- The T-Clip is used to mount the poles anywhere along the Rail (each FR2 comes with 2 T-Clips)
- The cross bars push the plastic or barrier material against the ceiling but do not hold the material securely in place, you must set up your barrier using the ZipWall® poles placed 8 to 10 feet apart which makes an incredibly secure & tightly sealed barrier

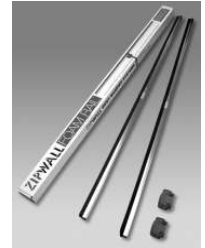

Item #	Desc.
ZWFR2	(2) 5' Foam Rail cross bars & (2) T-clips

ZIPWALL, LLC

ZipWall® Pole Kit

- The Kit 20 poles extend from 6' 9" to 20 feet and can be used in areas with a ceiling height up to 21 feet
- The spring loaded plunger called the jack screws onto the end of the pole and adds a foot of reach
- The poles can be placed 8 to 10 feet apart
- If there is any significant air movement that pushes the plastic you will need to pull them in closer together, anywhere from 4 to 8 feet
- If the poles are placed closely together you may need two or more people to attach them to the plastic and raise them into place
- The GripDisk™ slide stoppers should always be used especially on hard surfaces; two GripDisk™ slide stoppers come in every Kit 20 package



Item #	Desc.
ZWKIT-20	(2) 20' extension poles, (2) spring-loaded jacks, (2) grip disks & (2) tethers

ZIPWALL, LLC

2-Pk Barrier System

- The SLP™ poles extend from 4' 9" to 12'
- The poles can be placed 8 to 10 feet apart; if there is any significant air movement that pushes the plastic you will want to pull them in closer together
- The GripDisk™ slide stoppers should always be used, especially on hard surfaces



Item #	Desc.
ZWSP2	(2) spring loaded poles, (2) grip disks & (2) tethers

ZIPWALL

ZIPWALL, LLC

4-Pk Barrier System

- The four SLP™ poles extend from 4' 9" to 12'
- To use the Foam Rails you will need to remove the head of the SLP™ pole by pulling the head straight off, then snap the Foam Rail onto the pole; each foam rail is five feet long
- The GripDisk™ should always be used, especially on hard surfaces



Item #	Desc.
ZW4PL	(4) SLPs, (2) Foam Rail cross bars, (4) Grip Disks, (2) ZipWall standard zippers, (1) Carry bag

ZIPWALL, LLC

ZipWall® Zipper

- Makes an easy doorway through plastic barriers
- Has the smoothest glide available
- Engineered with large sturdy easy-slide teeth
- Made with 2-sided pulls for easy entry/exit to or from the barrier
- Works best in temperatures above 55 degrees Fahrenheit
- The ZipWall® Zipper Knife™ sheeting cutter does not work with this zipper



Item #	Desc.
ZWZIPPER	(2) 7' self-adhesive zippers & (2) tie strings to support opening



ELECTROTAPE Utility Grade Duct Tape

Gray

Utility Grade duct tapes offer good adhesion in short-term, low-demand applications on relatively clean surfaces with light weather exposure.

- Adhesion: 50 oz/in
- Tensile Strength: 22 lb/in



Item #	Size (in. x yd.)
ET20602-1024	2x60

ELECTROTAPE

Contractor Grade Duct Tape

Colored

Contractor Grade tapes have a higher cloth thread count for greater strength, a thicker PE backing for increased durability and more adhesive for better holding power-particularly in typical construction environments.



- Adhesion: 45 oz/in
- Tensile Strength: 24 lb/in

Item #	Size (in. x yd.)	Color
ET203202	2x60	Red
ET203203	2x60	White
ET203208	2x60	Green
ET203209	2x60	Black

ELECTROTAPE

General Purpose Vinyl Electrical Tape

Black

- Economical all-purpose black electrical tape.
- Provides moisture-tight electrical and mechanical protection
- Weather resistant. Resists UV rays, acids, alkalis, abrasion, moisture, and corrosion
- Temperature range: 0°C to 80°C



Item #	Size (in. x ft.)
ET12060	¾x60

ELECTROTAPE

Premium Grade Vinyl Electrical Tape

Black

- Cold and heat resistant – suitable for all climates. Resists: UV rays, acids, alkalis, abrasion, moisture, and corrosion
- Tape maintains tensile strength, adhesion and integrity over Broad Temperature range: -18°C to 105°C
- Best all-around vinyl for primary electrical insulation for wire and cable splices rated up to 600 volts
- Meets ASTM D-3005 and HHI-595 specifications.



Item #	Size (in. x ft.)
ET107507-0100	¾x66



SURFACE SHIELDS
Electrical Marking Tape



- All weather
- Extremely flexible with good adhesion
- 7 mil
- UL listed

Item #	Size (in. x ft.)	Color
SFGRN066	¾x66	Green
SFGRY066	¾x66	Gray
SFORA66	¾x66	Orange
SFRED066	¾x66	Red
SFWHI066	¾x66	White
SFYEL066	¾x66	Yellow



ELECTROTAPE
Clean Removal Painters Grade Masking Tape

Blue



- UV resistant product with a specially formulated adhesive system permits clean removal from a wide variety of surfaces up to 14 days
- Highly versatile product suitable for use on glass, most wallpaper, metal, painted or unpainted wood, and stained or painted wall-board
- Not recommended for lacquer applications
- Tape Thickness: 5.5 mil; Adhesion: 22 oz/in
- Tensile Strength: 22 lb/in; Elongation: 6%

Item #	Size (in. x yd.)
ET25542	¾x60
ET25544	1x60
ET25546	1½x60
ET25548	2x60
ET25549	3x60

ELECTROTAPE
General Purpose Grade Masking Tape



- General purpose tape offering both economy and versatility
- Rated service temperature 32°F to 160°F (Not suitable for solvent based paints or oven bake cycles)
- Tape Thickness: 5.0 mil; Adhesion: 28 oz/in
- Tensile Strength: 19 lb/in; Elongation: 6%

Item #	Part #
ET25004	25004
ET25006	25006
ET25008	25008

ELECTROTAPE
Stucco / Trim Protection Tape



Red Stuck-O-Tape™

Stuck-O-Tape™ is the brand of choice for stucco professionals. It is a conformable low density polyethylene film, coated with an aggressive rubber-resin adhesive offering excellent aging characteristics – weather and UV resistant. Ideal for indoor or outdoor use as a surface protection and masking tape. Removes easily from surfaces as varied as masonry, wood, vinyl, painted metal and glass even after prolonged periods up to 30 days. Primarily used to mask window and door frames during stucco application to protect from overspray.

- All products are hand tearable. Black and white products are standard with serrated edges.
- Tape Thickness: 7.5 mil; Adhesion: 35 oz/in; Tensile Strength: 12 lb/in; Elongation: 450%

Item #	Size (in. x yd.)
ET145202	2x60

ELECTROTAPE
Standard Grade Friction Tape



- Cotton cloth impregnated with scientifically compounded pure rubber based adhesive for maximum elasticity and moisture resistance
- Standard color: black
- Tape Thickness: 15.0 mil; Tensile Strength: 40 lb/in

Item #
ET45008P-0030

ELECTROTAPE
Polyethylene Tape-Rubber Adhesive



- Serrated edges for easy, hand tearability
- Moisture & chemical resistant; NOT UV resistant
- Suitable for general purpose permanent patching, splicing, masking, and seaming
- Standard color: clear
- Tape Thickness: 7.0 mil; Adhesion: 60 oz/in
- Tensile Strength: 18 lb/in; Elongation: 80%

Item #
ET145236



ELECTROTAPE

Utility Grade Foil Tape

2 mil

- Seal duct work for heating, air conditioning and refrigeration systems
- Moderate temperature range. Max Temperature: 200°F
- Tape Thickness: 5.0 mil; Adhesion: 130 oz/in
- Tensile Strength: 15 lb/in



Item #	Size (in. x yd.)
ETS51323	3x50

ELECTROTAPE

Economy Filament Tape

100 lb

- Reinforced filament construction
- Constructed using conformable polypropylene backing, fiberglass filaments, and aggressive synthetic rubber adhesive



Item #	Size (in. x yd.)
ET300110	1x60

ELECTROTAPE

Contractor Grade PTFE Teflon Tape

- Tape Thickness: 4mil Standard Density: 0.28 gm/cm³ – 100% virgin PTFE
- Suitable for standard, non-challenging thread seal requirements
- Temperature range - 375°F to 500°F



Item #	Size (in. x in.)
ET55008PQ	1/2x520



SURFACE SHIELDS

Economy Grade Carton Sealing Tape

- Designed for lightweight cartons exposed to minimal stress in shipping and handling
- 1.6 mil thick



Item #	Size (in. x yd.)
SFCST4810	2x110



MASTER LOCK CO.

Laminated Steel Padlocks (No. 1)

- 1-3/4" wide heavy-duty laminated steel body for superior strength
- Hardened steel shackles for extra cut resistance
- 4-pin tumble cylinders provide pick resistance and dual locking levers provide extra pry resistance
- 3/4" horizontal shackle clearance; shackle is 5/16" diameter



Item #	Shackle Clear (in.)	Keyed
MAS1	1 ⁵ / ₁₆	Differently
MAS1KA	1 ⁵ / ₁₆	Alike
MAS1KALJ	2 ¹ / ₂	Alike

MASTER LOCK CO.

Laminated Steel Padlocks (No. 3)

- 1-9/16" wide laminated body for superior strength
- Hardened steel shackles for extra cut resistance; heavy-duty laminated steel case
- 4-pin tumbler cylinders provide pick resistance
- 5/8" horizontal shackle clearance; Shackle is 9/32" diameter



Item #	Shackle Clear (in.)	Keyed
MAS3	3/4	Differently
MAS3KA	3/4	Alike

MASTER LOCK CO.

Laminated Steel Padlocks (No. 5)

- 2" wide laminated steel body for superior strength
- Hardened boron alloy shackle for extra cut resistance
- 4-pin tumbler cylinders provide pick resistance
- 15/16" horizontal shackle clearance; Shackle is 3/8" diameter



Item #	Shackle Clear (in.)	Keyed
MAS5	1	Differently
MAS5KA	1	Alike

MASTER LOCK CO.

Universal Pin Padlocks

- Provide keying convenience; laminated steel bodies for superior strength
- Hardened steel (Nos. 1 and 3) and hardened boron alloy (No. 5) shackles
- 4-pin tumbler cylinders helps prevent picking



Item #	Shackle Clear (in.)
MAS1UP	1 ⁵ / ₁₆
MAS1UPLJ	2 ¹ / ₂
MAS3UP	3/4
MAS3UPLF	1 ¹ / ₂
MAS5UP	1
MAS5UPLF	1 ¹ / ₂



MASTER LOCK CO.
Combination Padlocks

No. 175



- 2" wide solid brass case for strength and weatherability
- Cut-resistat, hardened steel shackles
- Set-your-own 4-digit combination
- 1" horizontal shackle clearance; shackle has 5/16" diameter

Item #	Shackle Clear (in.)
MAS175	1
MAS175LH	2¼

MASTER LOCK CO.
Adjustable Locking Cable

Python™



- Lock holds the cable tight at any position from 1' to 6'
- Interchangeable cables for application flexibility
- Cut Resistance - 3/8" 100% steel braided cable
- Weather tough and rust resistant aluminum lock body
- Scratch Resistant - Vinyl cable sleeve and lock body bumper

Item #	Type (ft.)
MAS8401D	KD Lock Only
MAS8405D	4' Cable Only
MAS8406D	6' Cable Only
MAS8412D	12' Cable Only
MAS8430D	30' Cable Only

MASTER LOCK CO.
Safety Lockout Hasp



- Tamper-resistant scissor-style steel lock-out hasp
- Allows for lockout by up to 6 workers
- 1-3/4"x4-1/2", 1" inside jaw diameter

Item #
MAS420

MASTER LOCK CO.
Safety Lockout Padlocks



- Designed exclusively for lockout/tagout
- Durable, lightweight, non-conductive Xenoy® lock body
- Customize on-site with permanent, write-on labels
- Key retaining - ensures that padlocks are not left unlocked
- 1/4" dia. shackle, 1-1/2" high clearance
- Keyed different

Item #	Color
MAS410RED	Red
MAS410BLU	Blue
MAS410GRN	Green
MAS410YLW	Yellow

MASTER LOCK CO.
Lockout Tags



"DO NOT OPERATE"

- Durable polyester laminate resists water, grease and extreme temperature
- Heavy-duty construction meets OSHA requirement and prevents accidental removal
- Customize with name, department, expected completion
- 7/16" dia. brass grommet accepts all safety padlocks
- Dimensions: 5-3/4" x 3-1/8"

Item #	Desc.
MAS497AX	Spanish/English 1 bag of 12 tags w/ties

MASTER LOCK CO.
Personal Lockout Kit



Modular Lockout/Tagout Organizer

- Safety lockout carrying case keeps important devices and padlocks together
- Kit includes high-use components, satisfying most applications
- Personal kits are for the individual worker; padlocks supplied are keyed alike for added worker convenience
- Includes permanent write-on labels (English, French, Spanish) that allow instant on-site customization for each worker
- High visibility red locks; Key-retaining - ensures that padlocks are not left unlocked
- Electrical & valve lockout focus

Contains:

- 3 ea. - 410KARED padlocks; 1 ea. - 7C5RED circuit breaker padlock; 1 ea. - 420 hasp; 1 ea. - 427 Snap-On hasp; 1 ea. - 8611 adjustable cable lockout; 1 ea. - 480, 1 - 481, & 1 - 482 gate valve covers; 1 ea. - 476, 1 - 477 ball valve covers; 1 pc. - 492, 2 pcs. - 493, 1 pc. - 494, 1 pc. - 495 circuit breaker lockouts; 1 pc. - 496 wall switch lockout; 1 ea. - 497A tags (12/pack)

Item #
MAS1457VE3KA



IRWIN INDUSTRIAL TOOLS
Carpenter Pencil Sharpener

- Uses 50% less pencil per sharpening cycle

Item #
IR233250



IRWIN INDUSTRIAL TOOLS
Carpenter Pencil

- 7" overall length

Item #
IR66300



IRWIN
Industrial Tools

IRWIN INDUSTRIAL TOOLS

Markers

**Permanent
Sharpie®**

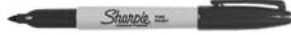

- Black permanent marker marks on wood, glass, plastic, metal, etc.

Item #
IR35010-SH

IRWIN INDUSTRIAL TOOLS

Markers

**Permanent
Sharpie®**



- A fine-tip marker designed to make a permanent impression on even the most hard-to-mark light and dark surfaces
- Features opaque metallic permanent ink in silver

Item #
IR39108-SH

IRWIN INDUSTRIAL TOOLS

Markers

**Permanent
Sharpie®**



- Blue fine-point permanent marker

Item #
IR30103-SH

IRWIN INDUSTRIAL TOOLS

Industrial Markers

King Size Sharpie®



- Industrial strength for tough marking jobs; Marks on wet and oily surfaces
- Durable aluminum barrel and felt tip stand up to heavy use; special water resistant ink formula dries quickly
- Excellent for marking corrugate, wood, metal, foil, stone, plastic and leather and more

Item #	Color
IR15001-SH	Black
IR15002-SH	Red

Call Edge for more options to mark & label.
Inquire about marking lumber, metal, & other materials.

IRWIN INDUSTRIAL TOOLS

**Rhino™ 5000 Pro
Labeling Tool**



**Hard Case Kit
Dymo® Rhino**

- Meets ANSI/TIA/EIA-606-A labeling standards
- “Hot keys” provide automatic label formatting for wires and cables, terminal blocks, patch panels, vertical and fixed length labeling
- Advanced wrap function automatically selects the right label size and the largest text size, based on cable size or wire gauge
- Quick-Access Symbols key for common datacomm and electrical symbols, including: ohm, ground, phone, data and fax
- Deluxe hard carry case, (1) 3/4” white flexible nylon label cartridge, (1) 3/4” white permanent polyester label cartridge, AC power adapter, (6) “AA” batteries

Item #	Desc.
DY15603	Rhino 5000 Hard Case Kit

IRWIN INDUSTRIAL TOOLS

Rhino™ 5000 Labels

Dymo® Rhino



- Labels for Professional Rhino™ 5000 Printer
- Shrink Tubes - 3:1 heat-shrink ratio, designed for any application requiring normal heat shrink tubing
- Vinyl - Ideal for outdoor and color-coding applications, all surfaces
- Poly - Flat surfaces. Equipment, bins, patch panels, etc.
- Nylon - Curved or flat surfaces. Wires, patch panels, machinery, equipment, bins, etc.

Item #	Size (in.)	Length (ft.)	Color
--------	------------	--------------	-------

Heat Shrink Tubes

DY18051	1/4	5	White
DY18053	3/8	5	White
DY18055	1/2	5	White
DY18057	3/4	5	White

Vinyl

DY18434	3/8	18	Orange
DY18439	3/4	18	Red
DY18445	3/4	18	White

Permanent Polyester

DY18483	1/2	18	White
DY18484	3/4	18	White
DY622289	1/2	18	Clear
DY622290	3/4	18	Clear
DY18485	3/8	18	Metal
DY18486	1/2	18	Metal
DY18487	3/4	18	Metal

Nylon

DY18488	1/2	11.5	White
DY18489	3/4	11.5	White



ELMDOR
Dry Wall Access Doors

DW Series



- Doors are ideally suited for new installations or for remodeling in masonry, tile, wood, or other wall surfaces; door features rounded safety corners
- 16 gage, galvanized steel with a prime coat finish
- Frame is one piece construction, 1" wide and provides perfect concealment of the rough wall opening; wall frame is provided with 1/4" mounting holes for fastening within the furred spaces
- Concealed pivoting rod hinge; doors 24" or larger are provided with a continuous piano hinge
- Latch is screwdriver operated; finish is a prime coat suitable for painting
- Optional Latches: CL- Cylinder Lock, AKL- Allen Key Latch, TH- T Handle; Optional Finish: SS- Stainless Steel

* Ask about locks, other stock & custom sizes as well as drywall bezel-style access doors - DWB Series

Item #	Size
EMDW6X6	6 X 6
EMDW8X8	8 X 8
EMDW10X10	10 X 10
EMDW12X12	12 X 12
EMDW14X14	14 X 14
EMDW16X16	16 X 16
EMDW18X18	18 X 18
EMDW24X24	24 X 24
EMDW30X30	30 X 30
EMDW36X36	36 X 36
EMDW48X48	48 X 48

ELMDOR
Fire Rated Access Doors

FR Series



- Doors are Fire Rated by Underwriters Laboratories Inc., for 1-1/2 hours, "B" Label, and meet ANSI-UL 10B standard; door has a heavy-duty spring closer to assure positive latching when panel closes - this door is for wall installation only; finish is a prime coat suitable for painting
- 16 gage, galvanized steel with a prime coat finish, door has a heavy-duty spring to assure positive latching
- Frame is equipped with both masonry anchors and bolt holes to facilitate installation in all types of wall construction; concealed hinge operates completely out of sight
- Exterior latch is recessed and is operated using a ring attached to the sliding bolt; interior latch release slide is included enabling door to be opened from the inside
- Opt. Latch: CL- Cylinder Lock; Opt. Finish: SS- Stainless Steel

* Ask about other stock & custom sizes

Item #	Size
EMFR8X8	8 X 8
EMFR12X12	12 X 12
EMFR18X18	18 X 18
EMFR24X24	24 X 24
EMFR36X36	36 X 36

ELMDOR
Fire Rated Access Doors

FRC Series



- Meets ANSI-UL 10B standards
- Doors are rated by Underwriters Laboratories for 1-1/2 hours, "B" label in walls, and by Warnock Hersey for 3 hours in ceilings and 2 hours in walls; door should be utilized when providing access in fire rated walls and ceilings; doors have heavy-duty spring closures to ensure positive latching when panel closes
- Door is fabricated from 20 gage, galvanized steel with a prime coat finish; door panel is provided with 2" of insulation in a sandwich type construction
- Frame is fabricated from 16 gage, galvanized steel with a prime coat finish and provided with masonry anchors and bolt holes
- Hinge is fully concealed and mounted on the long side of the rectangular door panel
- Exterior latch is a dual purpose lock that features a knurled knob and key operation; both are provided at time of shipping
- Interior latch release slide is included enabling door to be opened from the inside
- Option: MLP- Mortice Lock Prep

* Ask about other stock & custom sizes

Item #	Size
EMFRC8X8	8 X 8
EMFRC12X12	12 X 12
EMFRC18X18	18 X 18
EMFRC24X24	24 X 24

ELMDOR
Roof Access Hatch



- Elmdor roof access hatches are designed and engineered for durability and safety, with ease of installation
- The roof access hatch installs easily over the roof opening and is secured from the base flange to the roof
- Curb construction shall be 14 gage (G90) galvanized steel with durable recoatable gray primer finish; it shall be 12" in height with a 3-1/2" wide mounting flange with mounting holes for roof attachment
- Cover is 14 gage (G90) galvanized steel with radius corners for safety and shall be fully welded at the corners for watertight construction; latching includes interior handle, exterior handle and provisions for a padlock, both inside and out
- Hardware shall include an automatic, hold-open arm with vinyl grip and compression springs encased in telescopic tubes for smooth door operation
- Highly visible safety caution striping; durable recoatable gray primer finish (standard)
- Available in many sizes; special sizes available upon request

Item #	Size	Frame ID	Frame OD	Roof Opening
EMRAH24X24	24 x 24	31 x 31	24 x 24	115 / 52.1
EMRAH30X36	30 x 36	37 x 43	30 x 36	155 / 70.3
EMRAH36X36	36 x 36	43 x 43	36 x 36	200 / 90.7
EMRAH48X48	48 x 48	55 x 55	48 x 48	430 / 195



CENDREX

General Purpose Access Doors



Designed for a quick and easy installation on non-rated vertical and horizontal surfaces made of drywall or any other type of material. Rounded mitered corners, concealed pin hinge and 3/8" return all around the door make it the sturdiest door on the market. Prevents sagging as compared to flat door panels and requires fewer locks

- Material: 16 gauge cold rolled steel
- Hinge: Hidden pin hinge; continuous piano type on doors over 24" in height or width
- Lock / latch: Screwdriver operated cam latch
- Finish: DuPont high quality grey powder coat
- Available with drywall or plaster flange

Item #	Dimensions (in.)	Wall Opening (in.)
CXAHD8X8	8x8	8¼x8¼
CXAHD10X10	10x10	10¼x10¼
CXAHD12X12	12x12	12¼x12¼
CXAHD14X14	14x14	14¼x14¼
CXAHD16X16	16x16	16¼x16¼
CXAHD18X18	18x18	18¼x18¼
CXAHD24X24	24x24	24¼x24¼

CENDREX

Roof Hatch



Made of galvanized steel, designed to offer convenient access to building roof tops. Equipped with gas cylinders providing an effortless opening of the door panel. Heavy duty design and insulation ensure long life and low maintenance.

- Cover: 14 gauge galvanized steel with 1" fiberglass insulation
- Curb: 14 gauge galvanized steel with 1" fiber board insulation
- Seal: "D" - foam adhesive gasket provides a flush and tight fit
- Finish: High quality grey powder coat

Item #	Dimensions (in.)
CXTRH30X36	30x36
CXTRH36X36	36x36



GILMOUR

Hose Washers

- Rubber washers
- 10 per package



Item #
PK01RW

GILMOUR

Industrial Hose

Flexogen®

- Lightweight and soft, yet durable
- 6-ply, over 500 PSI burst strength
- O-ring for leakproof performance
- Flow-Guard Plus™ collar, prevents kinks near faucet

Item #	Size
PK10-58050	5/8"x50'
PK10-58100	5/8"x100'



GILMOUR

Pistol Grip Nozzle

- Insulated molded grip for spraying hot or cold water
- All brass valve stem with permanent adjusting nut
- Male hose threaded for attaching accessories



Item #
PK572TFR

GILMOUR

Twist Nozzle

- Solid brass body; all brass valve stem
- 3-turns-close to open



Item #
PK528

GILMOUR

Solid Stream Nozzle

- Solid brass body; streamlined design
- Ideal for cleaning driveways and walks



Item #
PK06BJ



COILHOSE

Reinforced Polyurethane Straight Hose

Flexeel®

- Flexeel® retains its flexibility even in cold environments
- Extremely lightweight and tough; reusable strain relief fitting



Item #	I.D. (in.)	Length (ft.)	Fitting (in.)	Colors
PCOPFE40504 Color	¼	50	¼ MPT	Transparent Blue (T), Transparent Red (TR), Transparent Yellow (TY)
PCOPFE41004 Color	¼	100	¼ MPT	Transparent Blue (T), Transparent Red (TR), Transparent Yellow (TY)



COILHOSE
Inner-Braided PVC Air Hose



- Special blend PVC has no memory: Hose lays down flat on the ground
- 180° bend radius: Hose won't kink and cut off air supply
- Steel spring strain relief: Protects hose at its weakest point (at the fitting) w/o inhibiting maneuverability
- UV stabilized; chemical and abrasion resistant; reusable fittings: Makes field repair quick and easy
- Temperature range: -40° F to 150° F
- Working Pressure: 325 PSI @ 70° F

Item #	I.D. (in.)	Length (ft.)	Fitting (in.)
PCOGF60245Q	3/8	25	1/4 MPT
PCOGF60504Q	3/8	50	1/4 MPT
PCOGF61004Q	3/8	100	1/4 MPT

GilaFlex Rigid Reusable Fitting w/ Strain Relief
PCOGFRM0604SR

COILHOSE
Reusable Hose Splicer



Item #	I.D. (in.)	O.D. (in.)
PCOPHS0406	1/4	3/8
PCOPHS0609	3/8	1/2

COILHOSE
1/4" Body Size Couplers

Industrial Interchange



Coilflow™

Item #	Thread & Barb Size (in.)
Female	
PCO150	1/4
Male	
PCO152	1/4

COILHOSE
1/4" Body Size Connectors

Industrial Interchange



Coilflow™

Item #	Thread & Barb Size (in.)
Female	
PCO1502	1/4
Male	
PCO1501	1/4

COILHOSE
3/8" Body Size Couplers

Industrial Interchange
Coilflow™



Item #	Thread & Barb Size (in.)
Female	
PCO580	3/8
Male	
PCO581	3/8

COILHOSE
3/8" Body Size Connectors

Industrial Interchange
Coilflow™



Item #	Thread & Barb Size (in.)
Female	
PCO5802	3/8
Male	
PCO5801	3/8

COILHOSE
1/2" Body Size Couplers

Industrial Interchange
Coilflow™



Item #	Thread & Barb Size (in.)
Female	
PCO120	1/2
Male	
PCO122	1/2

COILHOSE
1/2" Body Size Connectors

Industrial Interchange
Coilflow™



Item #	Thread & Barb Size (in.)
Female	
PCO1202	1/2
Male	
PCO1203	3/8



COILHOSE
1/4" Body Size Couplers

Automotive Tru-Flate Interchange Coilflow™



Item #	Thread & Barb Size (in.)
--------	--------------------------

Female

PCO160	1/4
PCO161	3/8

Male

PCO162	1/4
PCO165	3/8

COILHOSE
1/4" Body Size Connectors

Automotive Tru-Flate Interchange Coilflow™



Item #	Thread & Barb Size
--------	--------------------

Female

PCO1602	1/4
PCO1605	3/8

Male

PCO1601	1/4
PCO1603	3/8

COILHOSE
3/8" Body Size Connectors

Automotive Tru-Flate Interchange Coilflow™



Item #	Thread & Barb Size (in.)
--------	--------------------------

Female

PCO5904	1/4
PCO5902	3/8

Male

PCO5903	1/4
PCO5901	3/8

COILHOSE
1/4" Body Size Couplers

Lincoln Interchange Coilflow™



Item #	Thread & Barb Size (in.)
--------	--------------------------

Female

PCO170	1/4
--------	-----

Male

PCO172	1/4
--------	-----

COILHOSE
Automatic Universal Couplers

U Series Coilflow™



- Universal couplers are designed for use where there are connectors of different interchanges in use on the same application
- Fits type 14, 15 and 16 couplers

Item #	Thread & Barb Size (in.)
--------	--------------------------

Female

PCO150U	1/4
---------	-----

Male

PCO152U	1/4
---------	-----

COILHOSE
Blow Guns & Tips

600 Series



- The 600 Series blow guns are supplied with 1/4" NPT female inlet thread and 1/8" NPT female outlet thread
- "S" suffix blow guns conform to OSHA standards for noise levels (1910.95) and less than 30 PSI dead-ended pressure (1910.242B)

Item #	Desc.
--------	-------

PCO601	Rubber
PCO606-S	6" Safety Extension

COILHOSE
Air Chucks



Item #	Fitting (in.)	Desc.	Check Type
PCOCH09	1/4 FPT	Ball Chuck and Clip	Closed
PCOCH10	1/4 FPT	Ball Chuck and Clip	Closed



COILHOSE

Tee Manifold

- The tee manifold is made from high-quality brass and is ideal for two-way distribution



Item #	Desc. (in.)
PCOT004	1/4 FPT
PCOT006	3/8 FPT

COILHOSE

Tri-Pod Manifold

- This all aluminum manifold is available with three 1/4" FPT outlet ports and one 1/4" FPT inlet port or 3/8" inlet port for high volume applications



Item #	Desc.
PCO3002	3 Port (1/4" Inlet)
PCO3003	3 Port (3/8" Inlet)

COILHOSE

In-Line Lubricators

- Ideal for intermittent use type tools such as staplers and nailers



Item #	Oil Capacity (cc)	Length (in.)	Diameter (in.)	Weight (oz.)
PCO40014	5.0	3	1 1/2	5

COILHOSE

Air Tool Lubricant

- Lubricates and rust proofs; removes moisture
- Maximizes tool performance
- Avoids unnecessary service; prolongs tool life



Item #	Unit Volume (oz.)
PCOATL004	4
PCOATL016	16 (1 pint)
PCOATL128	128 (1 gallon)

COILHOSE

Air Tool Lubricant Wintergrade

- Coilhose ATLW provides lubrication down to -45°F
- ATLW anti-freeze lubricant can be applied via conventional air line lubricators or directly into the air tool's air inlet port



Item #	Unit Volume (oz.)
PCOATL004W	4
PCOATL016W	16 (1 pint)
PCOATL128W	128 (1 gallon)



CONTRACTORS CHOICE

Rubber Air Hose

- 300 PSI flexible rubber hose

Item #	I.D. (in.)	Length (ft.)
Hose With Guard and 1/4" fitting		
PIT3/8X25	3/8	25
PIT3/8X50	3/8	50
PIT3/8X100	3/8	100



Air Hose

PIT1/2X300	1/2	Bulk
PIT3/4X300	3/4	Bulk
PIT1X300	1	Bulk
PIT3/4X50	3/4	50



DIXON

Dixon Air King Couplings

Dixon "Air King" couplings are recommended for use on air lines for virtually any type of pneumatic equipment. The maximum recommended working pressure for Dixon "Air King" universal couplings is 150 PSI or less at ambient temperature (70° F).



- Made of malleable iron; blank ends available to block lines at coupling points
- Air King safety clips assure fittings will not become accidentally disconnected

Item #	Size (in.)
--------	------------

Hose Ends

PDIAM1	1/2
PDIAM5	5/8
PDIAM6	3/4
PDIAM11	1

Male NPT Ends

PDIAMB	3/8
PDIAM2	1/2
PDIAM7	3/4
PDIAM12	1

Female NPT Ends

PDIAMC	3/8
PDIAM3	1/2
PDIAM8	3/4
PDIAM13	1

Blank Ends

PDIAM0	-
--------	---

Accessories

PDIAC1	Safety Clip
PDIAWR4	Washer

SnappiHookers

SNAPPI HOOKER
Rubber Tie Down Straps



- Super strong S-hooks
- 100% EDPM UV resilient rubber; crack resistant

Item #	Length (in.)	Max Stretch (in.)
SNSH9"	9	22.5
SNSH15"	15	37.5
SNSH20"	20	50.5
SNSH30"	30	75

Construction Stakes

- Provide maximum reuse and productivity
- No more time spent locating, measuring and cutting wood
- Durable steel makes it easier to drive in tough soil conditions
- No more mushroomed, splintered or cracked wooden stakes
- The strength of steel stakes lets you space them farther apart
- Stakes maintain their point longer and resist bending and twisting out of position



Item #	Size (in.)	Desc.
RM3/4X18R	3/4x18	Round
RM3/4X24R	3/4x24	Round
RM3/4X30R	3/4x30	Round
RM3/4X36R	3/4x36	Round
RM3/4X48R	3/4x48	Round

Banding Seals

- Regular duty
- Double notch



Item #	Pkg. Qty.
PRM34SEAL	5000

Banding Tensioner

- Steel strapping tensioner
- 3/8 in. - 3/4 in.



Item #
PRMGRTNSNR34

Steel Banding

- Regular duty steel strapping
- 3/4" wide x .020 gauge
- Average break strength 2,078 lbs.



Item #
PRMST34020

Steel Strap Sealer

- Steel Strapping Sealer
- 3/4 in. Double Notch
- Regular Duty



Item #
PRMGRSL34RD2

Shrink Wrap

- 18"x1500' roll
- Clear, 80 gauge



Item #
PRM18POLY



THE WIND CLIP COMPANY
Propane Weed Burning Torch

**With 12' Hose
Nu-Way Torches**

- 500,000 BTU
- Cast iron head
- 3/8" x 18" double wall iron pipe handle
- Flame adjusting valve
- 12' hose and POL tank connection



Item #
NW5RC

**Edge
provides all kinds
of tie downs.**

**Contact your sales
representative.**



MIGHTY TIE
Cable Ties
Mighty Tie



- High quality nylon cable ties
- Made In The USA

Item #	Size (in.)	Color	Pkg Qty.
ACL4180C	4	UV Black	100
ACL4189C	4	Natural	100
ACL7500C	7	UV Black	100
ACL7509C	7	Natural	100
ACL11500C	11	UV Black	100
ACL11509C	11	Natural	100
ACL14500C	14	UV Black	100
ACL14509C	14	Natural	100
ACL241750L	24½	UV Black	50
ACL241759L	24½	Natural	50



ERIN ROPE CORPORATION
Polypropylene Rope

3 Strand Yellow



- Premium grade UV stabilized polypropylene fiber
- Versatile, economical, lightweight, floats

Item #	Dia (in.)	Length (ft.)	Min. Break Strength (lbs.)
ERTWPY080600	¼	600	1250
ERTWPY081200	¼	1200	1250
ERTWPY120600	¾	600	2440
ERTWPY121200	¾	1200	2440
ERTWPY160600	½	600	3780
ERTWPY200600	¾	600	5600
ERTWPY240600	¾	600	7650

ERIN ROPE CORPORATION
Conduit Measuring Tape



- Sequential footage marks from 1-3,000 ft.
- Allows for fishing and measuring conduit runs in one easy step

Item #	Width (in.)	Min. Tensile Strength (lbs.)	Length (ft.)
ERCMT3000	¼	130	3,000

ERIN ROPE CORPORATION
Manila Rope

3 Strand Natural Fiber



- The strongest of all natural fiber ropes
- Premium grade with 36 minimum becker value
- Items listed are 600' (additional lengths available)

Item #	Dia (in.)	Min. Break Strength (lbs.)
ERTWM160600	½	2,385
ERTWM200600	¾	3,960

ERIN ROPE CORPORATION
Premium Braided Nylon Twine

Mason Line



- High quality braided twine, will not unravel after multiple uses
- Size - #18, Length 1000'
- Min. Break Strength 157 lbs.

Item #	Color
ERBSTFG1000	Fluorescent Green
ERBSTFO1000	Fluorescent Orange
ERBSTFP1000	Fluorescent Pink
ERBSTFY1000	Fluorescent Yellow

ERIN ROPE CORPORATION
Pulling Rope

Composite Double Braid



- High tensile low stretch polyester double braided pulling rope with factory spliced pulling eyes at each end
- Items listed are 600' (also available in 1200')

Item #	Dia (in.)	Min. Break Strength (lbs.)
ERCDB160600	½	9,500
ERCDB240600	¾	26,000
ERCDB280600	7/8	32,000

ERIN ROPE CORPORATION
Pulling Tapes

Woven Polyester



- Low stretch, high strength, sequentially footage marked pulling tape
- Measure and pull with same product

Item #	Width (in.)	Approx. Tensile Strength (lbs.)	Length (ft.)
ERWP12503000	½	1250	3,000
ERWP18003000	¾	1800	3,000
ERWP25003000	¾	2500	3,000



LEAKTITE CORP.
5 Quart Polysteel Rim Pail

- Heavy-duty, high-quality polyethylene with spring-steel reinforced rims for maximum strength
- See through body with printed measurement on the outside
- Solvent resistant



Item #
LT0050CLR

LEAKTITE CORP.
5 Gallon Plastic Pail & Lids

- Great as a utility pail with optional lid
- Holds up to a 9" bucket grid
- White
- .070 wall thickness



Item #	Desc.
W5B	Pails
W5BLID	Lids



LEAKTITE CORP.
5 Quart Metal Pail Liner

- Solvent resistant plastic pail liner fits securely in the #5 metal pail
- Thermoformed construction, the liner keeps project cleanup time to a minimum
- Use with all types of paints



Item #
LT0050100

LEAKTITE CORP.
5 Gallon Pail Liner

- Semi-rigid, seamless plastic insert
- Great for quick color changes; cost effective for clean up



Item #
LT9003048

LEAKTITE CORP.
5 Gallon Pail Strainer

For Airless Sprayers

- Strains paint more efficiently; ideal for spraying or rolling
- New inlet accommodates hose while spraying
- Can be cleaned and reused or thrown away



Item #
LT9008040



PELICAN PRODUCTS
Watertight Protector Cases

- Made with Copolymer Polypropylene with open cell core and solid wall construction
- Stainless steel pins used for hinges and handles
- Double throw locks
- Tongue-and-groove fit with polymer o ring acting as a waterproof seal
- Automatic Pressure Equalization valve releases air pressure while keeping water out
- Pick n' Pluck foam for custom shaping the interior
- Single folding front handle



Item #	Size	Interior Dim. (in.)	Exterior Dim. (in.)
PU1200	Small	9 ³ / ₈ x7 ¹ / ₄ x4 ¹ / ₁₆	10 ⁵ / ₈ x9 ¹ / ₁₆ x4 ⁷ / ₈
PU1500	Medium	17x11 ⁷ / ₁₆ x6 ¹ / ₈	18 ¹ / ₂ x14 ¹ / ₁₆ x6 ¹ / ₁₆
PU1600	Large	21 ³ / ₄ x16 ¹ / ₁₆ x7 ⁷ / ₈	24 ¹ / ₄ x19 ⁷ / ₁₆ x8 ¹ / ₁₆



RUBBERMAID COMMERCIAL PRODUCTS
Trash Container
Brute®

- All-plastic, professional-grade construction will not rust, chip or peel; resists dents
- Strong, snap-on lids available for secure, stable stacking
- Reinforced rims add strength and durability
- Built-in handles all easy, non-slip lifting and anti-jam nesting
- Double-ribbed base increases stability and dragging capacity



Item #	Desc.	Cap. Gal.	Dia.	Dpth.	Wt
RB2632	Container w/o lid	32	22	27 ¹ / ₄	9.26
RB2631	Flat Lid for 2632 & 2634	32	22 ¹ / ₄	1 ³ / ₈	2.16



RUBBERMAID COMMERCIAL PRODUCTS

Angle Broom

- Ideal for cleaning hard-to-reach areas
- Cut and shaped for easy sweeping
- Long-lasting stain-resistant polypropylene bristles
- Permanent fusion set bristles won't pull out
- 1" dia. aluminum handle



Item #

RB6385

RUBBERMAID COMMERCIAL PRODUCTS

Plastic Dust Pan

- Redesigned dust pan with a thinner front edge for improved dirt pick up
- Includes molded-in, serrated teeth for counter duster cleaning
- 8-1/4" x 12-1/4" x 2-5/8"
- Color: Charcoal



Item #

RB2005

RUBBERMAID COMMERCIAL PRODUCTS

Spray Bottle

- Adjustable nozzle sprays up to 30"
- Large trigger for easy application
- 32 oz. HDRE bottle



Item #

RB9C03



PFERD ADVANCE BRUSH

Counter Duster

- Premium Fine Sweep
- Block Type: Wooden Block
- Filament Material: Black Horsehair & Nylon
- OA Length: 9"; Trim Length: 2-1/2"



Item #

MB89395

PFERD ADVANCE BRUSH

Floor Brooms

Fine Sweeping

- Block type: Lacquered hardwood
- Use with threaded handle

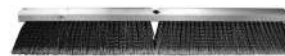

Item #	Filament	Trim Length (in.)	Block Size (in.)
MB89215	Horsehair / Nylon Mix	3	24
MB89223	Silver flagged-tip plastic	3	24

PFERD ADVANCE BRUSH

Floor Brooms

Medium Sweeping

- Block type: Lacquered hardwood
- Filament: Black tampico center fill with horsehair casing
- Use w/Handle: Threaded



Item #	Block Size (in.)	Trim Length (in.)
MB89253	24	3
MB89263	36	3

PFERD ADVANCE BRUSH

Floor Brooms

Coarse Sweeping

- Use with threaded handle
- Block type: Lacquered



Item #	Filament	Block Size (in.)	Trim Length (in.)
MB89287	Brown / Red Plastic	24	3
MB89319	Stiff Palmyra	16	4
MB89348	Brown Plastic	16	5/4

PFERD ADVANCE BRUSH

Wire Brooms

- Block Type: Lacquered Hardwood
- Filament Material: Round Steel Wire Center with Black Tampico Border
- Trim: 2-7/8"



Item #	Block Size (in.)
MB89362	18
MB89363	24

PFERD ADVANCE BRUSH

Broom Handles

- Wooden with Metal Threads
- Handle Length: 5'
- Handle Diameter: 15/16"



Item #

MB89889

PFERD ADVANCE BRUSH

Broom Handles

- Wooden with Tapered End
- Handle Length: 5'
- Handle Diameter: 1-1/8"



Item #

MB89899

PFERD ADVANCE BRUSH

Broom Handle Brace

- Adds strength and stability
- Heavy-duty brace clamps around handle



Item #

MB89922

PFERD ADVANCE BRUSH
Upright Broom



- Filament Material: Selected Corn
- No. Sews: 3
- Sweep Width: 11"
- Handle (Dia. x L): 1-1/8" x 37"
- OA Length: 56"
- Trim Length: 10-1/2"

Item #
MB89377

PFERD ADVANCE BRUSH
Floor Squeegees



- Heavy-Duty Straight
- Frame Plating: Cadmium Steel
- Blade Material: Neoprene

Item #	Blade Size (in.)	Length (in.)
MB89474	2x1/4	24

PFERD ADVANCE BRUSH
Floor Squeegees



- Heavy-Duty Curved Ends
- Frame Plating: Cadmium Steel
- Blade Material: Neoprene

Item #	Size (in.)	Length (in.)
MB89478	2 1/2 x 1/4	24
MB89480	2 1/2 x 1/4	36



PFERD ADVANCE BRUSH
Roller Frame



- OA Width: 9"
- Cage Diameter: 1-1/2"

Item #
MB89772

PFERD ADVANCE BRUSH
Paint Roller Refills



- Knitted polyester fabric
- PVC core
- Width: 9"
- Pile Height: 1/2"

Item #	Width (in.)	Pile Height (in.)
MB89757	9	1/2

PFERD ADVANCE BRUSH
Chip Brushes



- Wood handle
- White bristles

Item #	Width (in.)	Thickness (in.)	Trim Length (in.)
MB89696	1	5-16	1 1/2
MB89697	1 1/2	5-16	1 1/2
MB89698	2	3/8	1 3/4
MB89700	3	3/8	1 3/4
MB89701	4	3/8	1 3/4

PFERD ADVANCE BRUSH
Acid Brush



- Tin Handle with horsehair fill
- Width: 3/8"
- Trim: 7/8"
- OA Length: 6"

Item #
MB89602

PFERD ADVANCE BRUSH
Block Brush



- Straight back, wood handle
- Brush length: 7-1/4"
- Wire rows: 6x19; Filament: Carbon Steel
- Block width: 2-1/4"; Trim length: 1-3/4"

Item #
MB85082



ROOFMASTER PRODUCTS CO.
Magnetic Sweeper



- Designed to pick up nails, scrap metal & other metallic debris from decks, driveways & sidewalks, and grass & shrub areas
- Solid magnets

Item #	Size (in.)
RM452000	36 x 2
RM452400	24 x 2



Premium Trash Bags

- Significantly stronger than thicker bags made from conventional material
- Great for collecting trash and debris on the job site



Item #	Size (in.)	Pkg Qty.	Thickness (mil)
POHKHM42050B	33x48	50/Box	3
POHWY-4-55	38x65	55/Box	3
POPA2042HB	33x48	20/Box	3



AMSAN CUSTODIAL SUPPLY

Floor Sweeping Compound



Item #	Desc.	Weight (lbs.)
FLOOR SWEEP	Red - Oil Based	50
FLOOR SWEEP/WAX	Green - Wax Based	35



BUFFALO INDUSTRIES, INC.

Corduroy Rags

- Recycled corduroy pant material
- Excellent lower cost wiper

Item #	Size
BF10105	50 lb. Box



BUFFALO INDUSTRIES, INC.

Colored Cloth Rags

- Knit T-shirt material
- Suitable for almost all wiper needs

Item #	Size
BF5C	5 lb. Box
BF25C	25 lb. Box
BF50C	50 lb. Box



BUFFALO INDUSTRIES, INC.

Colored Sweatshirt Rags

- Sweatshirt material hand-picked for maximum absorbency
- Excellent all-purpose wiper

Item #	Size
BF25SS	25 lb. Box



BUFFALO INDUSTRIES, INC.

White Cloth Rags

- All white knit T-shirt material
- Excellent all-purpose wiping, cleaning, and polishing cloth
- Practically lint-free

Item #	Size
BF25W	25 lb. Box



BUFFALO INDUSTRIES, INC.

Heavy Weight Sorbent Pads

Oil Only-Meltblown

- Oil-Only sorbents absorb oil-based fluids such as motor oil & hydraulic/transmission fluid
- Meltblown sorbents are the most economical product available

Item #	Size	Per Bag
BF90850	15"x18" Pad	100



BUFFALO INDUSTRIES, INC.

Quick Response Spill Kit

Oil Only

Contains:

- 15 Oil only/med wt./bonded pads, 3 oil only 3"x4' socks, 1 pair Nitrile gloves, 1 disposable bag and instruction sheet

Item #
BF92001



BUFFALO INDUSTRIES, INC.

Econo Safety Pail Spill Kit™

Universal

Contains:

- Portable 5-gallon pail, 10 pads, 4 socks, 1 qt. Ensorb, 1 disposable bag and zip tie, 1 pair nitrile gloves and goggles, emergency response guide and instruction sheet

Item #
BF92000



WINTER ITEMS



TPI CORPORATION

Fan Forced Milkhouse Heater



- Heat settings plus fan only setting
- Temperature control thermostat
- 6' long - 3 conductor cord
- Triple safety system: Tip over switch, Automatic reset type limit control, Thermal cut-off device

Item #	Volts	Watts	Phase	Max. BTU's/Hr.
TPI188TASA	120	1500/1300 Fan Only	1	5120

TPI CORPORATION Combination Radiant

& Fan Forced Heaters



- 3-Heat settings
- Temperature control thermostat
- Dual safety system: Tip over switch, Manual reset type limit control
- 6' long - 3 conductor cord

Item #	Volts	Watts	Phase	Max. BTU's/Hr.
TPI198TMC	120	1500/900/600	1	5120



ENERCO® Convection Heaters

- Special Features: Piezo push button ignitor, Adjustable Heat Output, "Insta-Lock" system for easy assembly - no tools
- Specifications: Fuel: Propane Gas, Flame Safety: Thermocouple operated gas valve, Standing Pilot, Piezo ignition, Power required: None, POL/Excess flow check valve



Item #	Stock Number	Output BTU/hr	Propane Consumption (lbs/hr)	Pressure Regulator Settings	Hose - 20 ft.	Shipping Size LxWxH (in.)	Net Weight (lbs.)	Shipping Weight (lbs.)	Shipping Cube
HS80CV	F170480	30,000-80,000	1.4 to 3.7	11" W.C.	3/8" I.D. w/Regulator and POL	15.25x18.25x21.75	19	21	3.50
HS200CV	F170600	75,000-200,000	3.5 to 9.3	10 PSI	1/4" I.D. w/Regulator and POL	18.25x15x27.5	5 25	27	4.36

ENERCO®

Single Tank-top Propane Heater

w/ Piezo Ignitor

- Variable output of: 8, 12 & 14,000 BTU/hr
- Hi-Medium-Low Regulator; safety shutoff
- Operates 30-52 hours on a 20 lb. tank; connects to a 20 lb. cylinder



Item #	Stock Number
MH12T	F273100

ENERCO®

Double Tank-top Propane Heater

w/ Piezo Ignitor

- Variable output of: 8, 12, 16, 24 & 28,000 BTU/hr
- Hi-Medium-Low Regulator; two safety shutoffs
- Runs on one burner or two
- Operates 17-52 hours on a 20 lb. tank; connects to a 20 lb. cylinder



Item #	Stock Number
MH24T	F273600



L.B. WHITE
Forced Air LP/NG Heaters
Tradesman®

- LP and NG models available
- Ultra models include Self Diagnostic Service Saver for convenient trouble-shooting
- Dependable electronic spark ignition; superior Tri-Shield finish provides extended protection against abrasion and corrosion
- Thermostatic temperature control (Tradesman 170, 400 models); adjustable front leg provides easy direction of heat (170,400 models)
- Variable output saves fuel; direct-fired = 99.97% fuel efficiency
- CSA US, (all models) and Canada (all except 100K)



Item #	Btu/h Rating	Heated Air Output (CFM)	Fuel Consumption (max.) LP Gas (lbs./hr.)	Fuel Consumption (max.) Natural Gas (cu.ft./hr.)	Amps (starting/continuous operation)	Service Saver
LB100	50,000-100,000	350	4.6		4.7/2.0	
LB170	125,000 - 170,000	625	7.2	170	3.7/2.4	
LB170Ultra	125,000 - 170,000	625	7.2	170	3.7/2.4	Yes
LB400	250,000 - 400,000	1,582	18.5		3.7/2.4	
LB400Ultra	250,000 - 400,000	1,582	18.5		3.7/2.4	Yes

L.B. WHITE
Forced Air Kerosene Heaters
Tradesman®

- Kerosene, #1 diesel or #1 fuel oil
- Dependable, dual-prong electronic spark ignition
- Durable brass fuel fittings, not plastic
- Fuel gauge indicates remaining run time; comfort control thermostat
- Wheels and handles make it easier to maneuver
- Threaded drain plug
- CSA US and Canada



Item #	Btu/h Rating	Heated Air Output (CFM)	Pump Pressure (psi)	Fuel Consumption (max.) (gal./hr.)	Tank Capacity (gal.)	Operating Time/Tankful (hrs.)	Amps (continuous operation)	Motor Horsepower	Dimensions (LxWxH/in.)	Shipping Weight (lbs.)
LBK170	170,000	600	6.5	1.3	13	10.0	3.2	¼	43.5x23.9x26.6	60.0
LBK400	400,000	1,400	125	3.0	29	9.5	4.4	½	52.5x32.0x34.0	155.0
LBK650	650,000	3,600	110	4.9	50	10.0	7.1	¾	69.2x30.7x48.7	298.0



JACKSON SAFETY
Winter Liner
225 Plus

- Three layers of thick foam under a blue 100% quilted nylon shell; meets 16 CFR 1610, Class 1



Item #
JS3000442

JACKSON SAFETY
Winter Liner
AA-7 Windgard™

- Knitted tube cap style traps warmth and prevents moisture build-up, keeps wind out
- Flame retardant treated polyester - Navy blue color



Item #
JS3000434

JACKSON

JACKSON SAFETY **Winter Liner** AA-8 Windgard™

- Knitted tube hat style for 360 degree brim hats - Red color
- Warmth for temps 32° to 0° F (0° to -20°C)



Item #

JS3000436

JACKSON SAFETY **Winter Liner**

400

- Full head and neck coverage with extra-long nape and wrap-around collar
- 100% quilted nylon shell with 100% cotton; denim exterior; thick, sherpa lining for maximum warmth



Item #

JS3000441

JACKSON SAFETY **Winter Liner**

- Detachable bottom section is double layered, heavy knit spun polyester
- Top section is flame retardant treated; bottom section does not support combustion
- Red heavyweight fleece inner lining of top section; can be worn over hearing protection



Item #

JS3000439

RED STEER GLOVE COMPANY

RED STEER **Insulated Work Gloves** CHILLY GRIP®

- Chilly Grip® black heavy-duty foam rubber palm; brown acrylic thermal knit liner



Item #	Size
RSA315-M	Medium
RSA315-L	Large
RSA315-XL	Extra Large

YAKTRAX

YAKTRAX® **Outdoor Performance** **Footcare**

Traction Device **PRO**



The Yaktrax® Pro will instantly give you better traction, confidence and safety on packed snow or ice. Move about naturally with the same solid grip that you are accustomed to on dry surfaces. Walk or run as you normally would and experience stability on ice and snow like you have never felt before.

- High strength, abrasion resistant 1.4 mm steel coils
- Heavy-duty natural rubber material
- Provides 360 degrees of traction on packed snow and ice and can be worn in temperatures as low as -41° Fahrenheit
- Easy On/Off and walk naturally
- Spikeless/Ultralight
- Helps reduce the risk of falls & injuries

Item #	Size	Womens	Mens
YA08009	Sml	5-8½	6½-10
YA08011	Med	9-11	10½-12½
YA08013	Lrg	11½-13½	13-15
YA08015	XL	14+	15½+

UnionTools

UNION TOOLS **18" Plastic Snow** **Pusher**



- Deep 18-inch blade
- 50-1/2" ash handle
- Strong poly D-grip
- Made with high-density poly to withstand cold temperatures

Item #

UF16-274

UNION TOOLS **24" Aluminum Snow** **Pusher**



- 52" ash handle
- Durable aluminum blade with reinforced socket
- Steel wear strip breaks up ice and packed snow and extends blade life
- Wide D-grip accommodates a gloved hand

Item #

UF16-400



UNION TOOLS
18" Aluminum Snow Shovel



- 18-inch aluminum blade
- Strong poly D-grip
- 51" ash handle
- Steel wear strip for extended blade life

Item #
UF16-404

UNION TOOLS
18" Steel Snow Shovel



- 18-inch steel blade
- Strong poly D-grip
- 49-1/2" ash handle

Item #
UF16-407

UNION TOOLS
Poly Snow Scoop



- 14-inch x 18-inch scoop blade
- 46" ash handle
- Poly D-grip for added leverage and control
- Scoop blade won't scratch surfaces

Item #
UF16-815

UNION TOOLS
**Sidewalk/Ice Scraper
Razorback®**



- Professional grade forged construction for heavy-duty use
- Socket pattern
- 7" x 6" industrial gauge, forged blade
- 54" Ash wood handle

Item #
UF78-202

UNION TOOLS
Snow Roof Rake



- Aluminum handle extends to 17 feet
- 22-inch poly blade
- Non-slip handle treatment for control

Item #
UF16-345



Ice Melt



- 50 lb. bag
- Fast working; calcium chloride ice melt capable of melting at -25°F below zero
- Exothermic action gives off heat while dissolving, speeding the melting process

Item #
ICEMELT

Tube Sand



- 60 lb. Tube-o-Traction covers 1/2 cu. ft.
- Use for flood control and to add traction and weight to vehicles in bad weather

Item #
TUBESAND



YAKTRAX®
**Hand Warmers
Little Hotties®**



Open the bag, shake it, and stuff it!

- 1 Pair Hand Warmers; up to 8 Hours of Heat

Item #
YA07001

SUMMER ITEMS



THE SQUINCHER CORP.
Electrolyte Drinks

Ready-To-Drink Bottles



- Ready-to-drink; 24 per case
- 20 oz. wide-mouth plastic bottle

Item #	Flavor
SQ030530-BE	Berry
SQ030531-CI	Citrus
SQ030532-GR	Grape
SQ030534-OR	Orange
SQ030535-FP	Fruit Punch



THE SQWINCHER CORP.
Electrolyte Drinks
Fast Pack®



- Single-serving package eliminates the need for cups—each foil package is its own cup
- Add water to the liquid concentrate inside to make a 6-ounce single serving
- Easily fits in a pocket, lunch box or glove box
- Includes four 50-packs per case

Item #	Flavor
SQ015301-CH	Cherry
SQ015302-GR	Grape
SQ015303-LA	Lemonade
SQ015304-OR	Orange
SQ015305-FP	Fruit Punch
SQ015308-LL	Lemon-Lime

THE SQWINCHER CORP.
Electrolyte Drinks
Qwik Stik



- Pour in 20 oz. bottle of water
- 10/50 pk. per case

Item #	Flavor
SQ060100-OR	Orange
SQ060102-FP	Fruit Punch
SQ060106-LL	Lemon Lime
SQ060107-GR	Grape

THE SQWINCHER CORP.
Electrolyte Drinks
Powder Pack™



- Powder pack makes 2.5 gallons
- 32 pk. per case

Item #	Flavor	Case Qty/Yield	Wt
SQ016040-LA	Lemonade	32/80 gal.	1.53
SQ016041-OR	Orange	32/80 gal.	1.53
SQ016042-FP	Fruit Punch	32/80 gal.	1.53
SQ016043-LL	Lemon-Lime	32/80 gal.	1.53
SQ016046-GR	Grape	32/80 gal.	1.53



RUBBERMAID COMMERCIAL PRODUCTS
Water Coolers

Gott®

- Durable construction resists scratching, denting and fading
- Drip-resistant spigot; screw-tight lid
- Extra-thick insulation ensures superior thermal retention
- Stain and odor resistant, easy-to-clean liner
- Swing-top bail handle for easy carrying



Item #	Size (gal.)
IGGT1683	3
IGGT1685	5
IGGT1610	10

RUBBERMAID COMMERCIAL PRODUCTS
Mounting Bracket

- Designed specifically for Rubbermaid® water coolers
- Durable, weather-resistant construction
- Horizontal mounting



Item #	Desc.
IGGT1640	Rack

RUBBERMAID COMMERCIAL PRODUCTS
Cup Holder

- Designed specifically for Rubbermaid® water coolers
- Durable, weather-resistant construction

Item #	Desc.
IGGT8257UN	Dispenser



RUBBERMAID COMMERCIAL PRODUCTS
Paper Cone Cup

Solo®

- Cone shaped water cup with a rolled rim
- 25 sleeves of 200
- Per case = 5000 per case



Item #	Desc.
IG9346	Cups



TPI CORPORATION
Mini-Blower
Floor Model



- Totally enclosed motor allows mini-blower to be used in dirty or dusty environments; available as floor model or yoke mounted model that can be directly bolted to any surface or used with optional wall/ceiling mount
- Motor - 2-speed, 1/4 HP, 1 Phase, 115 volt, ball bearing, permanently lubricated, totally enclosed, permanent split capacitor
- Switch - Rotary on floor model, rocker on 30 Inch floor model with wheels and pull chain on yoke mounted model
- Cord - SJT type, 3 conductor, 10 Feet long; Blade - Aluminum; Guards - Spiral wire - front and rear
- Housing - Powder coated 20 ga. steel
- UL - Listed and meets OSHA Standards
- 1 Year Limited Warranty

Item #	Blade Size	CFM	Amps	Shipping Wt.
TPIMB-24-DF	24	6800/5000	2.2	52
TPIMB-30-DF	30	7800/6000	2.5	58

TPI CORPORATION
Belt Drive Portable Blower
Standard & Swivel



- Powder coated 20 gallon steel housing has front and rear roll formed embossments for added strength and rigidity
- Swivel model rotates 360° in 12.5° increments and locks in place with a steel locking pin
- 10 Inch Hard Rubber Wheels
- External junction boxes on dual voltage models allow units to be wired for either voltage without removing guards
- Hazardous Location Models have explosion proof motors and external junction boxes rated for Class I, Group D and Glass II, Groups E, F and G
- Meets OSHA Standards
- U.L. Listed
- 1 Year Limited Warranty
- Size - 36 Inch, 42 Inch and 48 Inch
- Motor - 1-speed, permanently lubricated ball bearing; Switch - Rocker on 115V 1 Phase models
- Cord - SJT type 3 conductor, 15 Feet long on 115V 1 Phase models, no cords on dual voltage models
- Blade - Steel on ODP models, aluminum on Hazardous Location models
- Guards - Spiral wire - front and rear

Item #	Blade Size (in.)	CFM	Amps	Weight (lbs.)	Motor Type	Motor HP	RPM	Base
TPIPB-36-B	36	14500	8.0	120	120 V 1 PH ODP	1/2	500	Standard
TPIPB-42-B	42	18200	11.0	155	120 V 1 PH ODP	3/4	430	Standard
TPIPB-48-B	48	22700	15.0	175	120 V 1 PH ODP	1	390	Standard
TPIPBS-36-B	36	14500	8.0/11.0	120	120 V 1 PH ODP	1/2	500	Swivel
TPIPBS-42-B	42	18200	11.0	155	120 V 1 PH ODP	3/4	430/390	Swivel
TPIPBS-48-B	48	22700	15.0	175	120 V 1 PH ODP	1	390	Swivel

TPI CORPORATION
Direct Drive Portable Blower - Standard and Swivel

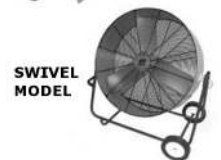

- Powder coated 20 gallon steel housing has front and rear roll formed embossment for added strength and rigidity
- Swivel model rotates 360° in 12-1/2 increments and locks in place with a steel locking pin
- 8" rubber wheels
- UL Listed and meets OSHA Standards
- 1 Year Limited Warranty

Item #	Blade Size (in.)	CFM (High/Low)	Amps	Shipping Wt.	Motor	Base
TPIPB-36-D	36	12500/9000	5.5	82	1/3	Standard
TPIPB-42-D	42	15600/1040	6.0	102	1/2	Standard
TPIPBS-36-D	36	12500/9000	5.5	110	1/3	Swivel
TPIPBS-42-D	42	15600/1040	6.0	128	1/2	Swivel



LEISURE CRAFT INC.

U-Leg Perforated Bench Without Back



- Perforated metal seat
- 3" 11-gauge steel legs
- Thermoplastic coated
- Pre-drilled mounting holes
- Several colors available, please inquire within

Item #	Desc.	Weight (lbs.)
LSULNB4-PERF	4'; No Back	110
LSULNB5-PERF	5'; No Back	120
LSULNB6-PERF	6'; No Back	130

LEISURE CRAFT INC.

U-Leg Perforated Bench



- 11 Gauge perforated metal seat and back
- 3" 11 Gauge tubular steel legs
- Thermoplastic coated
- Pre-drilled mounting holes
- Several colors available, please inquire within

Item #	Desc. (ft.)	Weight (lbs.)
LSULRF48-PERF	4	220
LSULRF72-PERF	6	250
LSULRF96-PERF	8	280

LEISURE CRAFT INC.

46" Square Perforated Table



- 11 Gauge perforated metal seats and tops
- Black powder coated galvanized steel 2" tubular understructure
- Thermoplastic coated
- Optional leg protectors and anti-skateboard tabs; optional umbrella; 1-3/4" umbrella hole
- All 46" tables are available in ADA version
- Handicap access is available for this model
- Several colors available, please inquire within

Item #	Desc.	Weight (lbs.)
LST46SQP-PERF	46" Square Perforated Portable Table	310
LST46SQSM-PERF	46" Square Perforated Surface Mount Table	315
LST46SQIG-PERF	46" Square Perforated In-Ground Table	320
LST46SQP-ADA-PERF	46" Square Perforated Table, 3 Seats, Handicap Access	275



TENNSCO

Ventilated Lockers

Single Tier



- Roomy enough for just about any secured storage application; ideal for use in factories, schools, fitness clubs, hospitals, and other locations where clothing is stored; three coat hooks and a coat rod per opening
- Available in single or three-wide units
- Opening size of 12" wide; locker depth of 18"; positive 3-point locking system in doors
- Available with or without legs; available fully assembled only
- Optional locks and other accessories available

Item #	No. of Openings	Opening (W, D, H)	Overall Unit (W, D, H)	Weight
--------	-----------------	-------------------	------------------------	--------

With Legs

TNVSL-121872-1	1	12, 18, 72	12, 18, 78	79
TNVSL-121872-3	3	12, 18, 72	36, 18, 78	237
TNVSL-151872-1	1	15, 18, 72	15, 15, 78	119
TNVSL-151872-3	3	15, 18, 72	45, 15, 78	260
TNVSL-181872-1	1	18, 18, 72	18, 18, 78	119
TNVSL-181872-2	2	18, 18, 72	54, 18, 78	237

Without Legs

TNVSL-121872-A	1	12, 18, 72	77	
TNVSL-121872-C	3	12, 18, 72	36, 18, 72	233
TNVSL-151872-A	1	15, 18, 72	119	
TNVSL-151872-C	3	15, 18, 72	45, 18, 72	260
TNVSL-181872-A	1	18, 18, 72	119	
TNVSL-181872-B	2	18, 18, 72	54, 18, 72	237

TENNSCO

Ventilated Lockers

Double Tier



- Features two openings per locker for twice the number of lockers in the same space with plenty of hanging room for shirts and jackets; three coat hooks per opening
- Available in single or three-wide units
- Opening size of 12" wide; locker depth of 18"; positive 2-point locking system in doors
- Available with or without legs; available fully assembled only
- Optional locks and other accessories available

Item #	No. of Openings	Opening (W, D, H)	Overall Unit (W, D, H)	Weight
--------	-----------------	-------------------	------------------------	--------

With Legs

TNVDL-121836-1	2	12, 18, 36	12, 18, 78	80
TNVDL-121836-3	6	12, 18, 36	36, 18, 78	240
TNVDL-151836-1	2	15, 18, 36	15, 18, 78	90
TNVDL-151836-3	6	15, 18, 36	45, 18, 78	240

Without Legs

TNVDL-121836-A	2	12, 18, 36	12, 18, 72	78
TNVDL-121836-C	6	12, 18, 36	36, 18, 72	238
TNVDL-151836-A	2	15, 18, 36	15, 18, 72	90
TNVDL-151836-C	6	15, 18, 36	45, 18, 72	240



<p>Numerics</p> <p>10-Person 10-Person Kits 332</p> <p>10-Person Kits 332</p> <p>11-in-1 Screwdrivers 200</p> <p>18V Batteries 22</p> <p>25-Person Kits 332</p> <p>2-Stroke Engine Engine Oil 386</p> <p>3M Fire Protection Products Duct Wraps 579 Fire Barrier Cast-In Devices 580 Fire Barrier Caulks 578 Fire Barrier Collars 579 Fire Barrier Mortars 579 Fire Barrier Pillows 579 Fire Barrier Putty Pads 578 Fire Barrier Sheets 579 Fire Barrier Sprays 579 Fire Barrier Wraps 579 Silicone Caulks 578 Spray Adhesives 588 Ultra Plastic Pipe Devices 580</p> <p>4-Bolt Breakers 352, 353</p> <p>4-Tool Kits 24</p> <p>50-Person 332 50-Person 332</p> <p>6-Way Screwdrivers 264</p> <p>A</p> <p>Abrasive Blades 382, 383</p> <p>Abrasive Wheels 66</p> <p>Abrasives Flap Discs Abrasives 566</p> <p>Accessories Nozzles Accessories 606</p> <p>Access Doors Drywall Access Doors 605 Fire Rated Access Doors 605</p> <p>Accessories Caulk Accessories 584 Cord Accessories 318 Generator Accessories 350 Harness Accessories 302 Nozzles Accessories 606 Respirator Accessories 321 Washers Accessories 606</p> <p>Accessory Kits Harness Accessory Kits 302</p> <p>Acid Brushes 389, 614</p> <p>Acoustical Sealants 583</p> <p>Acrylic Adhesives 506</p> <p>Acrylic Enamel Aerosols 585</p>	<p>Adapter Chuck Adapter 124</p> <p>Adapter Sheaves 176</p> <p>Adapters Adapters Blowers 367 Bit Adapters 379 Brush Adapters 557 Extension Cord Adapters 435 Impact Drive Adapters 254, 255, 256 Industrial-Duty Adapters 436 Ratchet Adapters 250, 252, 254, 255 Shaft Adapters 383 Socket Adapters 122 Tie-Off Adapters 300</p> <p>Adapters Blowers 367</p> <p>Adhesive Caulks 582</p> <p>Adhesive Mixing Nozzles 498</p> <p>Adhesive Zipper 598</p> <p>Adhesives Acrylic Adhesives 506 Construction Adhesives 582, 583 Epoxy Adhesives 506, 507 Spray Adhesives 588 Sub-Floor Adhesives 582</p> <p>Adjustable Wrenches 201, 262</p> <p>Aerial Work Aerial Work Platforms 214</p> <p>Aerial Work Platforms 214</p> <p>Air 548 Air 548</p> <p>Air Chucks 608 Air Chucks 608</p> <p>Air Compressors 345, 347, 348 Air Compressors 345</p> <p>Air Drills 350</p> <p>Air Hammer Chisels 359</p> <p>Air Hammers 350</p> <p>Air Ratchets 350</p> <p>Air Tool Lubricators 609</p> <p>Airman Air Compressors Compressors 347</p> <p>Ajax Tools Air Hammer Chisels 359 Breaker Bits 360 Chisel Bits 360, 361 Ground Rod Drivers 361 Pinch Bars 361 Pneumatic Scalers 360 Prick Punches 361 Pry Bars 361 Rivet Shank 360</p>	<p>Stock Wedges 361</p> <p>Alkaline Batteries 431</p> <p>Alignment Lasers 410</p> <p>Alignment Reamers 274</p> <p>All Thread Threaded Rod 494</p> <p>Allegro Industries 367 Adapters Blowers 367 Ducting Blowers 366 Electric Blowers 366, 367 Ventilation Ducts 367</p> <p>Allied Tube & Conduit Telescoping Square Telespar 592</p> <p>All-Purpose Harnesses 295</p> <p>Aluminum Handles 391</p> <p>Aluminum Bench 208</p> <p>Aluminum Hacksaws 161</p> <p>Aluminum Handles 391</p> <p>Aluminum Hawks 391</p> <p>Aluminum Scoops 290</p> <p>Aluminum Snips 265</p> <p>Aluminum Tripods 412</p> <p>American Power Pull Appliance Dollies 230 Industrial Hand Trucks 230</p> <p>Anchor Concrete Grip Anchor 307, 310 Hollow Wall Anchor 520 Roof Anchors 307, 311</p> <p>Anchor Bolts 534</p> <p>Anchor Setting Tool 504</p> <p>Anchor Shackles 222</p> <p>Anchor Strap 310 Anchor Strap 310</p> <p>Anchorage Connectors 300 Roof Anchors Permanent 308</p> <p>Anchorage Plates 300</p> <p>Anchors Beam Anchors 311 Concrete Anchors 519 Drive Pin Anchors 519 Drop-In Anchors 503, 504, 511, 512 Hammer-Screw Anchors 518 Masonry Anchors 514 Mushroom Head Anchors 520 Plastic Anchors 521 Roof Anchors 299, 300 Screw Anchors 501 Sleeve Anchors 502, 503, 513 Snake Setting Tool 516 Split Drive Anchors 520 Wallboard Anchors 520, 521</p>
---	---	---

<p>Wedge Anchors 509, 510, 511, 516</p> <p>Wedge-Bolt Anchors 515</p> <p>Anchors Telespar 592</p> <p>Angle Brooms 613</p> <p>Angle Fittings 452, 453, 454, 465</p> <p>Angle Grinders 52, 58, 62, 63, 351</p> <p>Angle Protractors 173</p> <p>Annular Cutters 82</p> <p>Anti-Fatigue Mat 336, 337</p> <p>Anti-Fog Cloth 317</p> <p>Anvil 469, 470, 471, 472</p> <p>Apex 245, 246, 247, 248, 256, 257, 258, 264, 280, 282</p> <p>Bolt Cutter Jaws 283</p> <p>Bolt Cutters 283</p> <p>C- Clamps 261</p> <p>Cable Cutters 282, 283</p> <p>Center Punches 260</p> <p>Chuck Adapter 124</p> <p>Chuck Keyleashes 124</p> <p>Chuck Keys 123</p> <p>Cold Chisels 260</p> <p>Combination Wrenches 257, 258</p> <p>Construction Wrenches 259</p> <p>Deep Impact Sockets 246</p> <p>Deep Sockets 249, 251</p> <p>Drill Chucks 123</p> <p>Drive Extensions 250, 252</p> <p>Drive Ratchets 251, 254</p> <p>Flex Handles 252, 254</p> <p>Flex Head Ratchets 249, 252</p> <p>Fractional Sockets 245, 246, 247, 248, 249, 250, 251, 254</p> <p>Fractional/Metric Sockets 245</p> <p>Geared Box Tool Sets 256, 257</p> <p>Hex Keys 276, 277</p> <p>Hex Sockets 246, 248, 249, 251</p> <p>Hinge Handles 250</p> <p>Impact Drive Adapters 254, 255, 256</p> <p>Impact Extensions 253, 255</p> <p>Impact Sockets 247, 248, 253, 255</p> <p>Inspection Mirrors 260</p> <p>Keyless Drill Chucks 123</p> <p>Lobular Opening Sockets 255</p> <p>Long Handle Ratchets 252</p> <p>Long Pattern Wrenches 259</p> <p>Metric Sockets 246, 247</p> <p>Midget Combination Wrench 257</p> <p>Pin Punch 260</p> <p>Pinch Bars 260</p> <p>Punch & Chisel Set 259</p> <p>Quick Release Ratchets 246, 249</p>	<p>Ratchet Adapters 250, 252, 254, 255</p> <p>Ratchet Extensions 254</p> <p>Ratchet Repair Kits 253</p> <p>Rebar Cutter/Benders 282</p> <p>Ret Rings 255, 256</p> <p>Round Head Ratchets 252</p> <p>Screw Extractors 260</p> <p>Short Combination Wrench 257</p> <p>Short Pattern Wrenches 259</p> <p>Sliding T Handles 254</p> <p>Spark Plug Sockets 249, 250</p> <p>Speeder Handles 250, 252</p> <p>Spring Claws 260</p> <p>T- Handles 250, 252</p> <p>Teardrop Ratchets 251</p> <p>Torque Wrenches 259</p> <p>Universal Joints 250, 253, 254, 255</p> <p>Appliance Dollies 230</p> <p>Applicators</p> <p>Spray Applicators 591</p> <p>Aprons</p> <p>Electrical Aprons 341</p> <p>Arbors 109</p> <p>Arbors 109</p> <p>Carbon Steel Arbors 107</p> <p>Area Lighting 433</p> <p>Armstrong</p> <p>See Apex</p> <p>Arrestor</p> <p>Self-Retracting Arrestor 306</p> <p>Arrow Fastener Company, Inc.</p> <p>Hammer Tackers 281</p> <p>Manual Tackers 281</p> <p>Staples, Nails Staple Guns, Nail Guns 281</p> <p>Wire Tackers 281</p> <p>Asphalt Rakes 286</p> <p>Assemblies</p> <p>Ceiling Clip Assemblies 546</p> <p>Conduit Strap Assemblies 546</p> <p>R.A.D. Assemblies 56</p> <p>Threaded Rod Assemblies 546</p> <p>Tie Strap Holder Assemblies 547</p> <p>Atlas Copco</p> <p>Breakers 357</p> <p>Ergonomic Scalars 358</p> <p>Pick Hammers 358</p> <p>Rock Drills 358, 359</p> <p>Attachments</p> <p>Drill Attachments 70</p> <p>Right Angle Attachments 55</p>	<p>Auger Bits 169</p> <p>Aviation Snips 265</p> <p>Awls</p> <p>Scratch Awls 203</p> <p>Axes</p> <p>Pulaski Axes 285</p> <p>B</p> <p>Back Pad</p> <p>Harness Back Pad 304</p> <p>Back Supports 343</p> <p>Backer Rod 398</p> <p>Backfill Tampers 357</p> <p>Backfill Tampers 357</p> <p>Backpack Sprayers 399</p> <p>Bags</p> <p>Electrode Bags 202</p> <p>Tool Bags 338, 339, 340</p> <p>Bags Trash 615</p> <p>Ball Pein Hammers 278, 289, 290</p> <p>Band Saw Blades 110</p> <p>Band Saw Kit</p> <p>Band Saw Kits 42</p> <p>Band Saw Kits 42</p> <p>Band Saws 37, 48, 54, 57, 64, 79</p> <p>14 Band Saws 88</p> <p>Bands</p> <p>Hearing Bands 319</p> <p>Bare Expansion Tools 42</p> <p>Barricade Repair Hardware</p> <p>Telespar 595</p> <p>Barricade Tapes 335</p> <p>Barriers Systems</p> <p>Dust Barriers Systems 599, 600</p> <p>Bars</p> <p>Connecting Bars 204</p> <p>Crow Bars 284</p> <p>Pinch Bars 260, 361</p> <p>Post Hole Bars 284</p> <p>Pry Bars 279, 280, 361</p> <p>Ripping Bars 279</p> <p>San Angelo Bars 284</p> <p>Scraper Bars 279</p> <p>Tool Bars 204</p> <p>Utility Bars 280</p> <p>Wrecking Bars 280, 284</p> <p>Bases</p> <p>Post Bases 551</p> <p>Basin Wrenches 128</p> <p>Batter Boards</p> <p>System Batter Boards 92</p> <p>Batteries 541</p>
--	---	---



Alkaline Batteries 431	Heater Benders 173	Wood Bits 117
Batteries 541	Lever Benders 143	Wood Boring Bits 169
Batteries Cordless 47	Mechanical Benders 171	Woodboring Bits 117
Batteries Radios 333	Offset Benders 170	Blade Kit 124
Battery Cordless 47	Rebar Cutter/Benders 282	Blade Kits
Chargers Batteries 43	Tube Benders 143, 170	Kits Shears 77
Cordless Tool Batteries 43, 48, 67, 539	Tubing Benders 143	Blades 376
Lithium-Ion Batteries 42, 48, 59, 60, 66	Bending Shoe 172	Abrasive Blades 382, 383
NiCad Batteries 65	Bending Shoe Groups 171, 172	Band Saw Blades 110
Ni-CD Batteries 66	Bending Tables 172	Blades 376
Ni-MH Batteries 65, 66	Bernzomatic	Circular Saw Blades 78, 109, 110
NiMH Batteries 65	Propane Torches 159	Cutter Blades 134, 135
Pack Batteries 25	Spark Lighters 159	Diamond Blades 383, 384, 385, 386
Batteries Cordless 47	Bibs Rain Gear 330	Dry Saw Blades 379
Batteries Radios 333, 334	Big Foot	Flush Cut Blades 104
Batteries 21, 22	Blade Kit 124	High Speed Saw Blades 381
Battery Chargers 22, 25, 26, 43, 47, 65, 67	Binder Chains 227	Jig Saw Blades 105
Battery Cordless 47	Biscuits	Kerf Saw Blades 66
Battery Cordless Tool 541	Joining Biscuits 91	Knife Blades 270
Battery Powered	Bit Adapters 379	Masonry Saw Blades 381
Crimp Tool Battery Powered 186, 187	Bit Extensions 118	Metal Cutting Blades 109
Battery-Powered CCX Tools 178	Bits 74	MultitMaster Diamond Blades 71
Battery-Powered Crimpers 180	Auger Bits 169	MultitMaster E-Cut Blades 71
Beam Anchors 311	Breaker Bits 360	MultitMaster Saw Blades 71, 72
Beam Clamp Straps 457, 461	Carbide Bits 92, 93, 94, 101	Pointing Saw Blades 379
Beam Clamps 457, 458, 459, 467, 468	Carbide-Tipped Bits 98	Reciprocating Saw Blades 102
Bearing Plates 550	Chisel Bits 98, 100, 360, 361	Saw Blades 66, 76, 376
Belt	Chisels Bits 97	Saw Circular 77
Harness Belt 303, 304	Contractor Bits 111	Sawzall Blades 102, 103, 104
Belt Sanders 39, 64	Core Bits 98, 380, 387	Segmented Blades 380
Belts	Cored Bits 386	Steel Saw Blades 66
Leather Belts 343	Countersink Bits 166	Tile Blades 385, 386
Tool Belts 341, 342	Demolition Hammer Bits 99	Tuckpoint Blades 383, 384
Bench	Drill Bits 168, 169	Tungsten Carbide Blades 103
Aluminum Bench 208	Hammer Bits 100, 101	Turbo Saw Blades 379, 381
Drywall Bench 225	Hammerdrill Bits 94	Utility Knife Blades 271
Bench Chain Vise 129	Hex Bits 120, 121	Blades Cutters 154
Bench Grinder Bushings 561	Hex Insert Bits 120, 121	Blankets
Bench Grinders 37	Impact Bits 169	Heating Blankets 173
Bench Wheels 567	Installer Bits 117	Blow Guns Guns 608
Benches 622	Masonry Bits 98, 99, 100	Blowers
Benches 622	Multipurpose Bits 96	Ducting Blowers 366
Perforated Benches 622	Pilot Bits 109	Electric Blowers 366, 367
Work Benches 234, 236	Plumbers Bits 111	Portable Blowers 365, 621
Benders	Power Bits 168	Blow-Out Bulbs 514
Cable Benders 181	Rotary Hammer Bits 97	Bobs
Conduit Benders 172, 185	Self-feed Bits 110	Plumb Bobs 413
Hand Benders 170	Spade Bits 116	Bolt Cutter Jaws 283
	Square Drive Bits 555	Bolt Cutters 283
	Steel Bits 101, 118	Bolt Dies 141
	Step Bits 118, 168	Bolts
	Stop Bits 96	Anchor Bolts 534



Hanger Bolts 493 Hex Bolts 493 Lag Bolts 494 Toggle Bolts 520 Booster Cable 426 Boots PVC Boots 328 Traction Boots 325, 618 Bosch Tools Battery Chargers 67 Circular Saws 67, 68 Cordless Tool Batteries 67 Cut-Off Machines 69 Drill Attachments 70 Electric Breaker Hammers 69 Electric Combo Hammers 68, 69 Electric Engravers 75 Electric Grinders 69 Electric Hammer Drills 68 Electric Hammerdrills 68 Electric Nibblers 69, 70 Electric Rotary Hammers 69 Electric Routers 70 Electric Shears 69 Electric Tappers 68 Heat Guns 70 Jig Saw Blades 105 Jig Saws 68 Jobsite Radios 67 Reciprocating Saws 67 Shank Chucks 70 Trim Saws 67 Worm Drive Saws 67 Bottle Spray Bottle 613 Bottle Jacks 230 Bow Rakes 285, 291 Box Brackets 488 Box End Wrenches 126 Box Hangers 489 Box Nails 534 Box Saws 293 Boxes Liquid Transfer Boxes 234 Portable Cable Boxes 434 Tool Boxes 236, 237 Truck Boxes 237, 238, 239, 240 Vehicle Underbed Boxes 234 Welders Boxes 235 Braces Broom Handle Braces 613 Brackets	Box Brackets 488 Faceshield Brackets 314 Mounting Brackets 457 Strap Mounting Brackets 244 Brackets Roof 213 Brackets Telespar 594 Brad Nails 534, 538 Brass Hammers 290 Breaker Bits 360 Breaker Hammers Electric Breaker Hammers 62, 69 Breakers 357 4-Bolt Breakers 352, 353 Breakers 357 Pavement Breakers 35 Bricklayer Sets 280 Bricklaying Trowels 393 Bricks Rub Bricks 388 Broom Handle Braces 613 Broom Handles 613 Brooms Angle Brooms 613 Concrete Brooms 388 Floor Brooms 613 Upright Brooms 614 Wire Brooms 613 Brush Adapters 557 Brushes Acid Brushes 389, 614 Bucket Brushes 389 Cable Cleaning Brushes 190, 191 Chip Brushes 614 Cleaning Brushes 135 Counter Dusters 613 Cup Brushes 557 Masonry Brushes 389 Mold Cleaning Brushes 191 Scratch Brushes 557 Wheel Brushes 558 Wire Brushes 557, 614 Bubble Levels 161 Bucket Brushes 389 Bucket Liners 612 Bucket Organizers 342 Buckets Plastic Buckets 612 Polysteel Buckets 612 Tool Buckets 201, 202 Buffalo Industries, Inc. Cloth Wipers 615 Colored Rags 615	Corduroy Rags 615 Kit 335, 615 Oil Sorbents 336, 615 Safety Kit 335, 615 Buildex 524, 526, 527, 528, 529, 530 Concrete Sammys 525 Metal Sammys 524 Sammys Nut Drivers 525 Sammys Pole Tools 525 Socket Kit Pole Tools 525 Steel Sammys 522, 523 Toggle Sammys 526 Wood Sammys 521, 522 X-Press It Sammys 525 Building Enclosure Films 596 Buildings And Matters, LLC 160 Hole Cover 160, 387 Bulbs Blow-Out Bulbs 514 Krypton Bulbs 431 Bulbs Flashlights 433 Bull Floats 390 Bull Pin Holders 202 Bull Pins 204 Bull Point Chisels 95 Bulbs Light Bulbs 426 Bump Caps 314 Bumps Speed Bumps 331 Burdy 186 Crimp Tool Battery Powered 186, 187 Dies 186 Hydraulic Crimpers 187 Hydraulic Cutters 187 Burs Carbide Burs 558, 560, 561 Bushing Chisels 95 Bushings Bench Grinder Bushings 561 Plastic Bushings 561 C C Clamps 262, 263 C- Clamps 261, 284 C.S. Unitec, Inc. Band Saws 79 Concrete Grinder 80 Concrete Saws 80 Hack Saws 79 Magnetic Drills 80
--	---	--



<p>Rotary Hammers 80</p> <p>Cabinets</p> <p>Storage Cabinets 182, 234, 235, 237, 244</p> <p>Tool Cabinets 233</p> <p>Cable</p> <p>Booster Cable 426</p> <p>Retractable Cable 309</p> <p>Cable Benders 181</p> <p>Cable Cleaning Brushes 190, 191</p> <p>Cable Connecting Molds 189, 190, 192, 193</p> <p>Cable Connector Portable/Temp Anchorage Connectors 308</p> <p>Cable Crimpers 181</p> <p>Cable Cutters 122, 179, 180, 197, 282, 283</p> <p>Cable Cutters 122</p> <p>Cable Dispensers 183, 184</p> <p>Cable Feeders 175</p> <p>Cable Firestop Systems 576</p> <p>Cable Management</p> <p>Cable Ties Cable Management 611</p> <p>Cable Padlocks 603</p> <p>Cable Pullers 176, 224</p> <p>Cable Pulling Lubricants 177</p> <p>Cable Sleeves 301</p> <p>Cable Splicers 203</p> <p>Cable Staples 282</p> <p>Cable Strippers 181, 198</p> <p>Cable Ties Cable Management 611</p> <p>Cable/Conduit Supports 490</p> <p>Cables</p> <p>Cables Connectivity 334</p> <p>Drain Cleaner Cables 147, 148, 149</p> <p>Galvanized Wire Cables 227</p> <p>Ground Rod Cables 190</p> <p>Portable Cable Boxes 434</p> <p>Tee Cables 191</p> <p>X Cables 191</p> <p>Cables Connectivity 334</p> <p>Caddies</p> <p>Carry Caddies 237</p> <p>Handy Caddies 183</p> <p>Wire Caddies 183</p> <p>Caddy/Erico 468, 490</p> <p>Beam Clamps 467, 468</p> <p>Box Brackets 488</p> <p>Box Hangers 489</p> <p>Cable/Conduit Supports 490</p> <p>Conduit Clips 488</p> <p>Conduit Hangers 490</p>	<p>Conduit Supports 489</p> <p>Flange Clips 488</p> <p>Light Fixture Clips 489</p> <p>Light Fixture Hangers 491</p> <p>Pipe Sleeve Positioners 489</p> <p>Pipe Supports 491</p> <p>Protection Plates 489</p> <p>Purlin Clips 489</p> <p>Rod and Wire Hangers 491</p> <p>Rod Hangers 489</p> <p>Strap Hanger Clips 490</p> <p>Strut Clamps 488</p> <p>Wire Hangers 491</p> <p>Cadweld/Erico 190</p> <p>Cable Cleaning Brushes 190, 191</p> <p>Cable Connecting Molds 189, 190, 192, 193</p> <p>Flint Igniters 191</p> <p>Ground Rod Cables 190</p> <p>Grounding Weld Metals 189</p> <p>Handle Clamps 191</p> <p>Horizontal Conductors 191</p> <p>Horizontal Splices 191</p> <p>Mold Cleaning Brushes 191</p> <p>Mold Sealers 191</p> <p>Tee Cables 191</p> <p>X Cables 191</p> <p>Camera Extensions 145</p> <p>Cameras</p> <p>Cordless Cameras 155</p> <p>Digital Cameras 47</p> <p>Inspection Cameras 145, 146</p> <p>Campbell</p> <p>See Apex</p> <p>Canister Vacuums 84</p> <p>Cans</p> <p>Safety Cans 244, 335</p> <p>Trash Cans 612</p> <p>Caps</p> <p>Bump Caps 314</p> <p>Column Caps 552</p> <p>End Caps 447, 448, 463, 464</p> <p>Post Caps 551</p> <p>Protective Caps 315</p> <p>Rebar Protector Caps 396</p> <p>Safety Caps 315</p> <p>Caps & Crosses</p> <p>Telespar Caps & Crosses 594</p> <p>Carabiner Hooks 300</p> <p>Carabiner Temporary Anchorage Connectors 308</p> <p>Carbide Bits 92, 93, 94, 101</p>	<p>Carbide Burs 558, 560, 561</p> <p>Carbide Tipped</p> <p>Carbide Tipped Blades 89</p> <p>Carbide Tipped Blades 89</p> <p>Carbide-Tipped Bits 98</p> <p>Carbon Hook Loadbinders 229</p> <p>Carbon Steel Arbors 107</p> <p>Carbon Steel Dies 272, 273</p> <p>Carbon Steel Taps 273, 274</p> <p>Carpenter Pencils 424, 603</p> <p>Carpenter Squares 416</p> <p>Carpet Protection 597</p> <p>Carry Caddies 237</p> <p>Cartridges</p> <p>Epoxy Cartridges 496</p> <p>Carts</p> <p>Cricket Carts 158</p> <p>Grasshopper Carts 158</p> <p>Utility Carts 183, 231</p> <p>Wire Carts 183</p> <p>Cases</p> <p>Laser Level Cases 415</p> <p>Caster Sets 237</p> <p>Cast-In Devices</p> <p>Fire Barrier Cast-In Devices 580</p> <p>Castings</p> <p>Manhole Hooks Municipal Castings 152</p> <p>Caulk</p> <p>Concrete Caulk 406, 408, 581</p> <p>Caulk Accessories 584</p> <p>Caulk Guns 20, 48, 583, 584</p> <p>Caulk Nozzels 584</p> <p>Caulk Spatulas 584</p> <p>Caulks</p> <p>Adhesive Caulks 582</p> <p>Fire Barrier Caulks 578</p> <p>Silicone Caulks 578</p> <p>CCX Tools</p> <p>Battery-Powered CCX Tools 178</p> <p>Ceiling Clip Assemblies 546</p> <p>Ceiling Wire 491</p> <p>Cell Phone Holders 343</p> <p>Cells</p> <p>Fuel Cells 539, 541</p> <p>Cendrex 606</p> <p>Center Punches 260</p> <p>Certified Safety Manufacturing Inc.</p> <p>10-Person Kits 332</p> <p>25-Person Kits 332</p> <p>50-Person 332</p> <p>Chain Hoists 220</p>
--	--	---

<p>Chain Lanyards 298</p> <p>Chain Saw 363</p> <p>Chain Saws 363</p> <p>Chain Vises 129</p> <p>Chain Wrenches 127</p> <p>Chaining Construction Products</p> <p> Socket Channel 256</p> <p>Chains</p> <p> Binder Chains 227</p> <p> High Test Chains 228</p> <p> Proof Coil Chains 228</p> <p>Chalk Lines 422, 423</p> <p>Chalk Reels 418</p> <p>Chalks</p> <p> Refill Chalks 423</p> <p>Channel</p> <p> Socket Channel 256</p> <p>Channel Fittings 466</p> <p>Channel Joiners 463</p> <p>Channel Nuts 448, 449, 463, 465</p> <p>Channellock</p> <p> Adjustable Wrenches 262</p> <p> Concrete Nippers 261</p> <p> Cutting Pliers 261</p> <p> LinemensPliers 262</p> <p> Pliers 262</p> <p> Slip Joint Pliers 262</p> <p> Tongue & Groove Pliers 261</p> <p>Channels</p> <p> Electrical Channels 464</p> <p> Round Hole Channels 444</p> <p> Slotted Channels 465</p> <p> Solid Channels 444, 445, 446, 447, 464, 465</p> <p>Chapin Manufacturing Inc</p> <p> Backpack Sprayers 399</p> <p> Concrete Sprayers 399</p> <p> Degreasing/Cleaning Sprayers 399</p> <p>Chargers</p> <p> Battery Chargers 22, 25, 26, 43, 47, 65, 67</p> <p> Vehicle Chargers 22</p> <p>Chargers Batteries 43</p> <p>Chargers Radios 334</p> <p>Checkpoint Laser</p> <p> Laser Level Cases 415</p> <p> Laser Levels 415, 416</p> <p> Torpedo Levels 415</p> <p>Chests</p> <p> High-Capacity Chests 233</p> <p> Tool Chests 232, 233, 235, 236</p> <p> Vehicle Chests 235</p>	<p>Chicago Pneumatic Tool Co. 355</p> <p> 4-Bolt Breakers 352, 353</p> <p> Air Drills 350</p> <p> Air Hammers 350</p> <p> Air Ratchets 350</p> <p> Angle Grinders 351</p> <p> Backfill Tampers 357</p> <p> Chipping Hammers 356</p> <p> Combi Drills/Hammers 355</p> <p> CPS Rivet Busters 354</p> <p> Die Grinders 351</p> <p> Engraving Pens 351</p> <p> Impact Wrenches 350</p> <p> Needle Scalars 351</p> <p> Pistol Grip Hammers 350</p> <p> Portable Compressors 346</p> <p> Ratchets 351</p> <p> Reciprocating Saws 351</p> <p> Scabblers 354</p> <p>Chip Brushes 614</p> <p>Chipping Hammers 356</p> <p>Chisel Bits 98, 100, 360, 361</p> <p>Chisels</p> <p> Air Hammer Chisels 359</p> <p> Bull Point Chisels 95</p> <p> Bushing Chisels 95</p> <p> Cold Chisels 260</p> <p> Concrete Chisels 99</p> <p> Flat Chisels 95</p> <p> Ground Rod Chisels 95</p> <p> Scaling Chisels 95, 96</p> <p> Wood Chisels 292</p> <p>Chisels Bits 97</p> <p>Chocks</p> <p> Wheel Chocks 331</p> <p>Chop Saw Wheels 66</p> <p>Chop Saws 38, 64</p> <p>Chuck Adapter 124</p> <p>Chuck Keyleashes 124</p> <p>Chuck Keys 123</p> <p>Chucks</p> <p> Drill Chucks 123</p> <p> Keyless Drill Chucks 123</p> <p> Nipple Chucks 141</p> <p> Shank Chucks 70</p> <p>Circular Saws 27</p> <p>Circular Saw Blades 78, 109, 110</p> <p>Circular Saws 28, 43, 47, 49, 55, 61, 67, 68</p> <p>Clamp Lights 429</p> <p>Clamp Meters 46</p> <p>Clamp-On Meters 182</p>	<p>Clamps</p> <p> Beam Clamps 457, 458, 459, 467, 468</p> <p> C Clamps 262, 263</p> <p> C- Clamps 261</p> <p> Conduit Clamps 460, 461</p> <p> Flashlight Clamps 432</p> <p> Handle Clamps 191</p> <p> Pipe Clamps 157, 461, 462, 466</p> <p> Sheet Metal Clamps 263</p> <p> Strut Clamps 488</p> <p> Tubing Clamps 461</p> <p> Welding Clamps 157, 263</p> <p>Clamps 284</p> <p>Claws</p> <p> Spring Claws 260</p> <p>Clean Mats Protection 598</p> <p>Cleaner</p> <p> Electronic Cleaners 587</p> <p>Cleaners</p> <p> Closet Augers 146</p> <p> Contact Cleaners 589</p> <p> Drain Cleaners 146, 147, 148, 149</p> <p> Drain Line Cleaners 149</p> <p> Electronic Cleaners 587</p> <p> Heavy Duty Degreasers 589</p> <p> Lens Cleaners 317</p> <p> Maintenance Cleaners 587</p> <p>Cleaners Cordless Tool 539, 589</p> <p>Cleaning Brushes 135</p> <p>Cleaning Wipes 321, 590</p> <p>Clevis</p> <p> Rope Clevis 177</p> <p>Clevis Hangers 466</p> <p>Clips</p> <p> Conduit Clips 488</p> <p> Cradle Clips 450</p> <p> Flange Clips 488</p> <p> Light Fixture Clips 489</p> <p> Panel Clips 554</p> <p> Purlin Clips 489</p> <p> Roof Clips 553</p> <p> Strap Hanger Clips 490</p> <p> Wind Clips 597</p> <p> Wire Rope Clips 228</p> <p>Closet Augers 146</p> <p>Closure Strips 447</p> <p>Cloth</p> <p> Anti-Fog Cloth 317</p> <p>Cloth Wipers 615</p> <p>Clothing</p> <p> Jackets Clothing 329</p>
--	---	--



<p>Coated Gloves 323</p> <p>Coilhose 607</p> <ul style="list-style-type: none"> Air Chucks 608 Air Tool Lubricators 609 Blow Guns Guns 608 Connectors 607, 608 Couplers 607, 608 In-Line Lubricators 609 Polyurethane 606 Splicer 607 Tee Manifolds 609 Tri-Pod Manifolds 609 <p>Cold Chisels 260</p> <p>Coleman Cable Inc. 429</p> <ul style="list-style-type: none"> Clamp Lights 429 Electrical Cords 433 Extension Cord Adapters 435 Extension Cords 433, 434, 435 Generator Cord Adapters 435 GFCI Cords 435 Lighting Guards 429 Portable Cable Boxes 434 Shop Lights 429 Temporary Light Strings 429 Temporary Power Cords 434 <p>Collar Firestop 573</p> <p>Collars</p> <ul style="list-style-type: none"> Fire Barrier Collars 579 <p>Collets and Nuts 74</p> <ul style="list-style-type: none"> Collets and Nuts 74 <p>Colored Rags 615</p> <p>Columbus McKinnon Corp. 221, 222, 223, 224, 371</p> <ul style="list-style-type: none"> Anchor Shackles 222 Chain Hoists 220 Lever Hoists 218, 219 Quick Links 223 Wide Range Trollies 219 Wire Rope Grips 224 Wood Handle Hookaroons 371 <p>Column Caps 552</p> <p>Combi Drills/Hammers 355</p> <p>Combination Bench & Pipe Vise 142</p> <p>Combination Drills 116</p> <p>Combination Padlocks 603</p> <p>Combination Squares 414, 415, 416</p> <p>Combination Taps 274</p> <p>Combination Wrenches 257, 258</p> <p>Combo Hammers</p> <ul style="list-style-type: none"> Electric Combo Hammers 68, 69 <p>Combo Kits</p> <ul style="list-style-type: none"> Cordless Combo Kits 48, 58, 59 	<p>Common Nails 533</p> <p>Compact Press Tools 144</p> <p>Compact Threading Machines 154</p> <p>Compactors</p> <ul style="list-style-type: none"> Gas Compactors 395 <p>Composite Sheets</p> <ul style="list-style-type: none"> Fire Barrier Sheets 573 <p>Compound Action Snips 265</p> <p>Compounds</p> <ul style="list-style-type: none"> Floor Sweeping Compounds 615 <p>Compressors</p> <ul style="list-style-type: none"> Air Compressors 347, 348 Air Compressors Compressors 347 Portable Compressors 346 <p>Concrete Anchors 519</p> <p>Concrete and Steel Pins 544, 545</p> <p>Concrete Brooms 388</p> <p>Concrete Caulk 406, 408, 581</p> <p>Concrete Chisels 99</p> <p>Concrete Cleaner 408</p> <p>Concrete Cutting Saws 375</p> <p>Concrete Dampproofing 404</p> <p>Concrete Darbies 389</p> <p>Concrete Edgers 389, 390</p> <p>Concrete Forms 398</p> <p>Concrete Foundation 404</p> <p>Concrete Gliders 390</p> <p>Concrete Grinder 80</p> <p>Concrete Grip Anchor 307, 310</p> <p>Concrete Groovers 391</p> <p>Concrete Hardener 400</p> <p>Concrete Inserts 464</p> <p>Concrete Mixers 394</p> <p>Concrete Nippers 261</p> <p>Concrete Placers 291, 392</p> <p>Concrete Planers 65</p> <p>Concrete Pulls 392</p> <p>Concrete Push Saws 374</p> <p>Concrete Rakes 284</p> <p>Concrete Sammys 525</p> <p>Concrete Saws 80, 373, 374, 377, 378</p> <p>Concrete Sealer Compound 401, 404, 405, 406</p> <p>Concrete Sprayers 399</p> <p>Concrete Tampers 392</p> <p>Concrete Vibrators</p> <ul style="list-style-type: none"> Cordless Concrete Vibrators 19, 59 <p>Conductors</p> <ul style="list-style-type: none"> Horizontal Conductors 191 <p>Conduit Benders 172, 185</p> <p>Conduit Clamps 460, 461</p> <p>Conduit Clips 488</p>	<p>Conduit Cutters 184</p> <p>Conduit Dispensers 177</p> <p>Conduit Hangers 490</p> <p>Conduit Measuring Tapes 194, 611</p> <p>Conduit Pistons 175</p> <p>Conduit Reamers 203</p> <p>Conduit Strap Assemblies 546</p> <p>Conduit Supports 489</p> <p>Cones</p> <ul style="list-style-type: none"> Traffic Cones 330 <p>Connecting Bars 204</p> <p>Connection Points</p> <ul style="list-style-type: none"> Harness Connection Points 303 <p>Connector Brackets Telespar 594</p> <p>Connectors 607, 608</p> <ul style="list-style-type: none"> Anchorage Connectors 300 Connectors 607, 608 End Connectors 463 Hanger Connectors 462 Industrial Connectors 436 <p>Construction Adhesives 582, 583</p> <p>Construction Electrical Products</p> <ul style="list-style-type: none"> 426, 427 Booster Cable 426 Flood Lights 426 Light Bulbs 426 Trouble Lights 426 Work Lights 426 <p>Construction Hammers 279</p> <p>Construction Harnesses 295</p> <p>Construction Stakes 399, 610</p> <p>Construction Staplers 539</p> <p>Construction Wrenches 259</p> <p>Contact Cleaners 589</p> <p>Contacting Elements</p> <ul style="list-style-type: none"> No Mar Contacting Elements 540 <p>Contractor Bits 111</p> <p>Contractor Grade Wheelbarrows</p> <ul style="list-style-type: none"> 370 <p>Contractor Lifts 156, 214</p> <p>Contractors Choice 609</p> <p>Contractors Saws 87</p> <p>Control 437</p> <ul style="list-style-type: none"> Control 437 <p>Convection 369, 616</p> <ul style="list-style-type: none"> Convection 369, 616 <p>Converters</p> <ul style="list-style-type: none"> Vacuum Hose Converters 86 Vacuum Hose Couplings 86 <p>Cooper Hand Tools 266</p> <ul style="list-style-type: none"> Aluminum Snips 265 Compound Action Snips 265
---	--	---



Folding Rules 419
 Tape Measures 418, 419
 Wood Rules 419

Cooper Tools - Apex Division
 Hex Bit Holders 121
 Hex Bits 120, 121
 Hex Drive Nutsetters 122
 Hex Insert Bits 120, 121
 Socket Adapters 122

Copper Lens Glasses 318

Cord Accessories 318

Cord Plugs 435

Corded Press Tools 144

Cordless
 Cleaners Cordless Tool 539, 589

Cordless Cameras 155

Cordless Combo Kits 48, 58, 59, 60

Cordless Concrete Vibrators 19, 59

Cordless Drill/Drivers 17, 26, 27, 41, 57

Cordless Driver Drills 56

Cordless Hammer Drills 56

Cordless Hammerdrills 47

Cordless Lasers 412

Cordless ProPresses 144, 145

Cordless Screwdrivers 18

Cordless Shears 20, 27

Cordless Tool
 Battery Cordless Tool 541
 Lubrication Oil Cordless Tool 539

Cordless Tool Batteries 43, 48, 67, 539

Cordless Tool Flashlights 27, 58

Cords
 Electrical Cords 433
 Extension Cords 433, 434, 435
 Generator Cord Adapters 435
 GFCI Cords 435
 Safety Vests 326
 Temporary Power Cords 434

Corduroy Rags 615

Core Bits 98, 380, 387

Core Drills Rigs 372

Cored Bits 386

Corrosion Inhibitors 585

Cotton Gloves 322

Counter Dusters 613

Countersink Bits 166

Couplers 607, 608
 Couplers 607, 608
 Flow Couplers 225

Coupling Nuts 494

Coveralls
 Protective Coveralls 330

Covers
 Joint Covers 464
 Plan Covers 598
 Receptacle Covers 463
 Shoe Covers 598

CPS Rivet Busters 354

Cradle Clips 450

Crayon Holders 424

Crayons
 Lumber Crayons 423

CRC Industries
 Contact Cleaners 589
 Heavy Duty Degreasers 589
 Multi-Purpose Lubricants 590
 Super Penetrants 589

Crescent
 See Apex

Cricket Carts 158

Crimp Tool Battery Powered 186, 187

Crimpers
 Battery-Powered Crimpers 180
 Hydraulic Crimpers 187
 Terminal Crimpers 198
 Wire Crimpers 198

crimpers
 Cable Crimpers 181

Crimping Tools Joiner 155

Cross Pein Hammers 289

Cross-Arm Strap Portable/Temp Anchorage Connectors 307

Crow Bars 284

Crown Staples 281

Cup Brushes 557

Cup Grinders 382

Cup Wheels 382, 567, 568

Curbs
 Parking Curbs 331

Current Tools, Inc.
 Hook-Type Sheaves 186
 Radius-Type Sheaves 186
 Tray-Type Sheaves 186

Cushion Grip Screwdrivers 199, 200

Cushion-Grip Screwdrivers 199, 200

Custom LeatherCraft
 Back Supports 343
 Bucket Organizers 342
 Cell Phone Holders 343
 Electrical Aprons 341
 Hammer Holders 343

Knee Pads 337, 338

Leather Belts 343

Leather Suspenders 344

PVC Boots 328

Rain Suits 327, 328

Tape Rule Holders 343

Tie Down Straps 344

Tool Bags 338, 339, 340

Tool Belts 341, 342

Tool Bucket Seats 342

Tool Holders 343

Tool Pouches 340

Work Gloves 324, 325

Work Suspenders 343

Cut-Off Machines 55, 69

Cut-Off Saws 55

Cutoff Saws 374, 375

Cut-Off Wheels 568, 569, 570

Cut-Out Tools
 Electric Cut-Out Tools 38

Cutter Blades 134, 135

Cutter Pliers 195, 196

Cutter Wheels 131, 133

Cutters
 Annular Cutters 82
 Blades Cutters 154
 Bolt Cutter Jaws 283
 Bolt Cutters 283
 Cable Cutters 179, 180, 197, 282, 283
 Concrete Saws 377
 Conduit Cutters 184
 Diagonal Cutters 197
 Hinged Cutters 151
 Hole Cutters 119, 125, 170
 Hydraulic Cutters 187
 Pipe Cutters 129, 130, 133, 134, 135, 152
 Pipe Threaders 138
 Power Threaders 138
 PVC Cutters 161
 Rebar Cutters 96
 Rod Cutters 184
 Side Cutters 195, 196, 197
 Tubing Cutters 46, 133, 134

Cutting
 Grinders Cutting 52

Cutting Fluids 96

Cutting Lubricants 587

Cutting Pliers 142, 194, 195, 261

Cylinder Pumps 227

Cylinders



<p>Hydraulic Cylinders 226 Single-Acting Cylinders 226</p> <p>D</p> <p>Dado Set 89</p> <p>Dampproofing Concrete Dampproofing 404</p> <p>Darbies Concrete Darbies 389</p> <p>DBI/SALA 294 All-Purpose Harnesses 295 Anchorage Connectors 300 Anchorage Plates 300 Cable Sleeves 301 Carabiner Hooks 300 Chain Lanyards 298 Construction Harnesses 295 Full Body Harnesses 294, 295, 296 Galvanized Lanyards 298 Hi-Vis Vests 296 Portable Horizontal Lifelines 299 Rescue/Retrieval Systems 301 Retro-Fit Tag 301 RFID Reader PDA 301 Roof Anchors 299, 300 Rope Grabs 299 Safety Harnesses 296 Safety Lanyards 297 Safety Lifelines 299 Self - Retracting Lifelines 298 Self Retracting Lifelines 298 Shock Absorbing Lanyards 296, 297 Tie-Off Adapters 300 Trauma Safety Strap 301 Vest Harnesses 294 Wall-Form Lanyards 298</p> <p>DC Pumps 241</p> <p>D-Cell Flashlights 433</p> <p>Dead Blow Hammers 289</p> <p>Deburring Tools 135, 151</p> <p>Deck Screws 554</p> <p>Dectector Laser 411</p> <p>Deep Impact Sockets 246</p> <p>Deep Sockets 249, 251</p> <p>Degreasing/Cleaning Sprayers 399</p> <p>Delineator Posts 331</p> <p>Delta Consolidated Industries 14 Band Saws 88 Carbide Tipped Blades 89 Contractors Saws 87 Dado Set 89 Dust Collectors 89</p>	<p>Hybrid Saws 88 Laser Drill Presses 88 Motor Saws 88 Professional Jointers 88 Variable-Speed Bench Drill Presses 88 Variable-Speed Grinders 89 Variable-Speed Lathes 88 Vehicle Ladder Racks 243 Vise Drill Presses 88</p> <p>Demolition Hammer Bits 99</p> <p>Demolition Hammers Electric Demolition Hammers 62</p> <p>Detection Tool Kits 45</p> <p>Detectors Multigas Detectors 312 Voltage Detectors 181</p> <p>Dewalt 17, 18, 19, 20, 21, 25, 26, 33, 34, 109 18V 20 18V Batteries 22 4-Tool Kits 24 5-Tool Kits 24 Abrasive Wheels 66 Band Saws 37 Battery Chargers 22, 25, 26 Belt Sanders 39 Bench Grinders 37 Carbide Bits 101 Carbide-Tipped Bits 98 Caulk Guns 20 Chisel Bits 98, 100 Chisels Bits 97 Chop Saw Wheels 66 Chop Saws 38 Circular Saws 27 Circular Saw Blades 109 Circular Saws 28 Concrete Chisels 99 Cordless Concrete Vibrators 19 Cordless Drill/Drivers 17, 26, 27 Cordless Lasers 412 Cordless Screwdrivers 18 Cordless Shears 20, 27 Cordless Tool Flashlights 27 Core Bits 98 Demolition Hammer Bits 99 Drill/Driver Kits 17, 23 Drivers Kits 24 Dust Extractor Vaccums 83 Dust Extractor Vacuums 83 Electric Cut-Out Tools 38</p>	<p>Electric Drills 30, 31, 32 Electric Grinders 35, 36, 37 Electric Hammerdrills 30 Electric Joiners 40 Electric Nibblers 38 Electric Polishers 37 Electric Routers 39, 40 Electric Sanders 38, 39 Electric Screwdrivers 32 Electric Shears 38 Filter Vaccums 83 Filter Vacuums 83 Flexible Floodlights 21 Grinder Pads 36 Hammer Bits 100, 101 Hammer Kits 24 Hammerdrill Kits 23 Impact Driver Kits 23 Impact Drivers 18 Impact Wrenches 18, 26, 27, 32, 33 Jig Saws 19, 28 Joist Drills 31 Lithium-Ion Batteries 21 Masonry Bits 98, 99, 100 Metal Cutting Blades 109 Miter Saw Stands 30 Miter Saws 29 Pack Batteries 25 Pavement Breakers 35 Pneumatic Nailers 40 Radios 22 Reciprocating Saws 19, 27 Right Angle Grinders 19, 35 Rotary Hammer Bits 97 Rotary Hammers 19, 33, 34 Saw Kits 24 Scroll Saw Stands 30 Scroll Saws 28 SDS DUST EXTRACTION SYSTEMS 26, 27 Steel Bits 101 Table Saw Stands 30 Table Saws 29 Track Saws 30 Vehicle Chargers 22 Wet/Dry Vacuums 22</p> <p>Diagonal Cutters 197</p> <p>Diamond Blades 383, 384, 385, 386</p> <p>Diamond Discs 385</p> <p>Diamond Products 373 Bit Adapters 379 Concrete Push Saws 374</p>
--	---	---

Concrete Saws 373, 374	Disposable Earplugs 318, 319	Rock Drills 358, 359
Core Bits 380	Distance Lasers 46	Screw Machine Length Drills 112
Core Drills Rigs 372	Dixon 609	Drills/Hammers
Cup Grinders 382	Docking Stations	Combi Drills/Hammers 355
Drill Rigs 372	Gas Detector Docking Stations 313	Drinks
Dry Grinders 381	Dollies	Electrolyte Drinks 333, 619, 620
Dry Saw Blades 379	Appliance Dollies 230	Water Coolers Drinks 332, 333, 620
Extension Rods 379	Standard Duty Dollies 230	Drinks Electrolyte 333, 620
Gas Powered Saws 373	Double End Drills 114	Drive Extensions 56, 250, 252
High Speed Saw Blades 381	Double Face Hammers 278	Drive Pin Anchors 519
Hole Saws 380	Double-Cut Shears 75	Drive Pins 542, 544, 545
Masonry Saw Blades 381	Dovetail Jigs 91	Drive Punches 163
Masonry Saws 373	Drain Cleaner Cables 147, 148, 149	Drive Ratchets 251, 254
Pointing Saw Blades 379	Drain Cleaners 146, 147, 148, 149	Driver
Push Saws 374	Drain Line Cleaners 149	Cordless Combo Kits 60
Segmented Blades 380	Drain Spades 291	Driver Gloves 321
Turbo Saw Blades 379, 381	Draw Studs 163, 165	Driver Kits
Vacuum Pumps Rigs 372	Drawers	Drill Driver Kits 40
Die Grinders 53, 351	Vehicle Drawers 242	Driver Punches 161
Die Heads 140	Drift Pins 204	Drivers
Dies 186	Drill Attachments 70	Cordless Driver Drills 56
Bolt Dies 141	Drill Bits 168, 169	Ground Rod Drivers 361
Carbon Steel Dies 272, 273	Drill Chucks 123	Hydraulic Drivers 161, 164, 165
Dies 186	Drill Driver Kits 40, 44	Impact Drivers 18, 41, 43, 56, 57
Pipe Dies 136, 137, 140, 141	Drill Kits	Nut Drivers 200, 201
Punch Dies 165	Hammer Drill Kits 40	Drivers Kits 24
Threading Machine Die Heads 136	Drill Presses	Drives
Diggers	Electromagnetic Drill Presses 54	Power Drives 137
Post Hole Diggers 284, 291	Laser Drill Presses 88	Dropin
Sledge Hammers 288	Variable-Speed Bench Drill Presses 88	Stainless Steel Dropin 519
Digging Bars 292	Vise Drill Presses 88	Drop-In Anchors 503, 504, 511, 512
Digging Bars 292	Drill Rigs 372	Drop-In Setting Tools 512
Digital Cameras 47	Drill/Driver Kits 17, 23	Dry Grinders 381
Digital Multimeters 45	Drill/Drivers	Dry Saw Blades 379
Direct Drive Fans 365, 621	Cordless Drill/Drivers 17, 26, 27, 41, 57	Drybrow Sweatbands 314
Disc Holders 566	Drills	Drywall 225
Discs	Air Drills 350	Stilts Drywall 225
Diamond Discs 385	Combination Drills 116	Drywall Access Doors 605
Dual Purpose Discs 572	Double End Drills 114	Drywall Bench 225
Fiber Discs 564	Electric Drills 30, 31, 32, 49, 50, 51, 54, 58, 61	Drywall Carts 225
Flap Discs 564, 565, 566	Electric Grinders 53	Drywall Carts 225
Hook & Loop Discs 567	Electromagnetic Drills 54	Drywall Hammers 391
Discs Guards 53	Extra Length Drills 113	Drywall Lift
Dispensers	Jobber Drills 111, 112, 114, 115, 116	Drywall 225
Cable Dispensers 183, 184	Joist Drills 31	Drywall Mixers 392
Conduit Dispensers 177	Magnetic Drills 80, 81	Drywall T-Squares 415
Tape Measures 177	Pilot Drills 109	Dual Purpose Discs 572
Wire Dispensers 183	Reduced Shank Drills 113	Dual Wheel Wheelbarrows 370
Dispensing	Right Angle Drills 51	Duct Protection 158, 599
Tools Dispensing 517		Duct Wraps 579
Dispensing Tools 518		Ducting Blowers 366
Dispensing Tools 518		Ducts



Ventilation Ducts 367	Electric Sanders 38, 39, 63, 64	Electric Engravers 75
Dura-Skrim 596	Electric Screwdrivers 32, 51	Engraving Pens 351
Dust Barriers Systems 599, 600	Electric Shears 38, 55, 65, 69, 76	Epoxy
Dust Collectors 89	Electric Tappers 68	Nuplabond Epoxy 292
Dust Collectors 89	Electric Winch 232	Epoxy Adhesives 506, 507
Dust Extractor Vaccums 83	Electrical Aprons 341	Epoxy Cartridges 496
Dust Extractor Vacuums 83	Electrical Channels 464	Erection Wrench Holders 202
Dust Pans 613	Electrical Cords 433	Erection Wrenches 201
Dustless Technologies	Electrician Hammers 278	Ergonomic Scalars 358
Canister Vacuums 84	Electrician Snips 203	Erin Rope Corporation
E	Electrode Bags 202	Conduit Measuring Tapes 194, 611
Eagle Manufacturing Co.	Electrolyte	Manila Rope 194, 611
Safety Cans 244, 335	Drinks Electrolyte 333, 620	Mason Twine 194, 611
Storage Cabinets 244	Electrolyte Drinks 333, 619, 620	Polypropylene Rope 611
Ear Plugs 320	Electromagnetic Drill Presses 54	Pulling Rope 194, 611
Ear Plugs 320	Electromagnetic Drills 54	Pulling Tapes 194, 611
Earmuffs	Electronic Cleaners 587	Erosion Control Fences 399
Safety Earmuffs 319, 320	Electronic Levels 413	Expansion Tool Kits 41, 45
Earplugs	Electrotape 600, 601, 602	Expansion Tools
Disposable Earplugs 318, 319	Elmdor	Bare Expansion Tools 42
Reusable Earplugs 318, 319	Drywall Access Doors 605	Extendable Levels 413
Edge Eyewear	Fire Rated Access Doors 605	Extension Cord Adapters 435
Copper Lens Glasses 318	Roof Access Hatch 605	Extension Cords 433, 434, 435
Cord Accessories 318	Empire Level	Extension Ladders 205, 206
Mirror Lens Glasses 318	Barricade Tapes 335	Extension Legs
Smoke Lens Glasses 318	Combination Squares 414, 415	Drywall Bench 225
Edgers	Drywall T-Squares 415	Extension Poles 543, 547
Concrete Edgers 389, 390	Flagging Tapes 335	Extension Rods 379
Elastomeric Sealants 575	Framing Squares 415	Extension Shafts 383
Electric Blowers 366, 367	I-Beam Levels 414	Extensions 225
Electric Breaker Hammers 62, 69	Magnetic Levels 414	Bit Extensions 118
Electric Combo Hammers 68, 69	Magnetic Protractors 414	Camera Extensions 145
Electric Cut-Out Tools 38	Masonry Levels 414	Drive Extensions 56, 250, 252
Electric Demolition Hammers 62	Plumb Bobs 413	Extensions 225
Electric Drills 30, 31, 32, 49, 50, 51,	Professional Squares 415	Impact Extensions 253, 255
54, 58, 61	Torpedo Levels 414	Ratchet Extensions 254
Electric Engravers 75	Try Squares 415	Shank Extensions 111
Electric Files 53	End Caps 447, 448, 463, 464	Socket Extensions 118
Electric Gliders 177	End Connectors 463	Wood Bit Extensions 117
Electric Grinders 35, 36, 37, 53, 63,	End-Cutting Pliers 195	Exterior 533
69, 77	Endless Slings 218	Exterior 533
Electric Hammer Drills 50, 68	Enerpac	Extinguishers
Electric Hammerdrills 30, 68	Cylinder Pumps 227	Fire Extinguishers 336
Electric Hole Cutters 142	Flow Couplers 225	Extra Length Drills 113
Electric Joiners 40	Hand Pumps 226, 227	Extractors
Electric Nibbler Attachment 76	Hydraulic Cylinders 226	Pipe Extractors 132
Electric Nibblers 38, 55, 69, 70	Hydraulic Oils 226	Screw Extractors 142, 260, 274
Electric Planers 64	Hydraulic Tool Sets 226	Eye Lag 533
Electric Polishers 37, 53	Manifold Pumps 227	Eye Lag 533
Electric Rotary Hammers 62, 69	Single-Acting Cylinders 226	Eye Lag Self Drilling 533
Electric Routers 39, 40, 70	Tube Spreaders 227	Eyeglass Cases 317
	Engravers	Eyeglass Hang Cords 317

<p>Eyewash Station Eyewash 334</p> <p>Eyewash Bottle Eyewash Bottle Eyewash 334</p> <p>Eyewash Bottle Eyewash 334</p> <p>EZ Roll, Inc. Caster Sets 237</p> <p>F</p> <p>Fabric Gloves 322</p> <p>Faceshield Brackets 314</p> <p>Faceshield Windows 316</p> <p>Faceshields General Purpose Faceshields 314</p> <p>Fairmont See Greenlee</p> <p>Fall Protection Kit 304, 310</p> <p>Fanaco Fasteners Brad Nails 534 Fine Wire Staples 535 Finish Nails 535 Galvanized Nails 541 Gun Nails 541 Medium Crown Staples 535 Positive Placement Nails 541 Roofing Nails 535 Siding Nails 535</p> <p>Fans Direct Drive Fans 365, 621 Floor Fans 365, 621</p> <p>Fasteners Fuel Cartridges 542, 544 Gas Fasteners 542 Powder Fasteners 544 Semi Automatic Fasteners 547</p> <p>Fasteners and Hardware Coupling Nuts 494 Fender Washers 495 Flat Washers 495 Hanger Bolts 493 Hex Bolts 493 Hex Nuts 494 Lag Bolts 494 Lock Nuts 494 Lock Washers 495 Threaded Rod 494</p> <p>Fasteners Telespar 594</p> <p>Fastening Tools 543</p> <p>Feeders Cable Feeders 175</p> <p>Feeding Sheaves 176, 177</p> <p>Fein Power Tools, Inc.</p>	<p>MultitMaster Carbide Rasps 72</p> <p>MultitMaster Diamond Blades 71</p> <p>MultitMaster E-Cut Blades 71</p> <p>MultitMaster Sanding Disc Sets 73</p> <p>MultitMaster Sanding Pads 73</p> <p>MultitMaster Sanding Sets 72, 73</p> <p>MultitMaster Sanding Sheets 72, 73</p> <p>MultitMaster Saw Blades 71, 72</p> <p>MultiMaster Cutting Blades 71</p> <p>MultiMaster Floor Kits 73</p> <p>MultiMaster Sawing Kits 73</p> <p>MultiMaster Scraper Blades 72</p> <p>MultiMaster Sets 71</p> <p>MultiMaster Wood Kits 73</p> <p>Vacuums 84</p> <p>Felt Tip Markers 424</p> <p>Fences Erosion Control Fences 399 Plastic Fences 399</p> <p>Fender Washers 495</p> <p>Ferrules Grounding Ferrules 228</p> <p>Fiber Cement Shears 122</p> <p>Fiber Discs 564</p> <p>Fiberglass Hammers 278</p> <p>Fiberglass Repair Kit 173</p> <p>File Handles 272</p> <p>Files Electric Files 53 Flat Files 271 Half Round Files 271 Knife Files 271 Machinist's Files 271 Mill Files 272 Round Files 271 Special Files 272 Square Files 272 Three Square Files 272</p> <p>Filter Bags Vacuum Filter Bags 86</p> <p>Filter Bags Vacuum 84</p> <p>Filter Vaccums 83</p> <p>Filter Vacuums 83</p> <p>Filters Vacuum Filters 85, 86</p> <p>Fine Wire Staples 535</p> <p>Finish Nailers 536, 537</p> <p>Finish Nails 535, 537</p> <p>Finish Saws 293</p> <p>Finishing Trowels 393</p> <p>Fire Barrier Cast-In Devices 580</p> <p>Fire Barrier Caulks 578</p>	<p>Fire Barrier Collars 579</p> <p>Fire Barrier Mortars 574, 579</p> <p>Fire Barrier Pillows 579</p> <p>Fire Barrier Putty Pads 578</p> <p>Fire Barrier Sheets 573, 579</p> <p>Fire Barrier Sprays 573, 579</p> <p>Fire Barrier Wraps 579</p> <p>Fire Extinguishers 336</p> <p>Fire Rated Access Doors 605</p> <p>Fire Swatters 292</p> <p>Firestop Collar Firestop 573</p> <p>Firestop Grommets 577</p> <p>Firestop Pillows 574</p> <p>Firestop Putties 575</p> <p>Firestop Sealants 575</p> <p>Firestop Systems Cable Firestop Systems 576 Sleeve Firestop Systems 573, 574</p> <p>First Aid Kits 332</p> <p>Fish Lines 174</p> <p>Fish Poles 174</p> <p>Fish Stix 174</p> <p>Fish Tapes 173, 174, 185</p> <p>Fishing Systems Power Fishing Systems 174, 175</p> <p>Fittings Angle Fittings 452, 453, 454, 465 Channel Fittings 466 Flat Plate Fittings 450, 451, 452 Gasketed Fittings 453 Hinge Fittings 459, 460 U Shape Fittings 454, 455 Wing Shape Fittings 455 Z Shape Fittings 454</p> <p>Flagging Tapes 335</p> <p>Flags Pennant Flags 331 Warning Flags 331</p> <p>Flange Clips 488</p> <p>Flange Pins 158</p> <p>Flap Discs 564, 565, 566 Flap Discs Abrasives 567</p> <p>Flap Discs Abrasives 566, 567</p> <p>Flap Wheels 564</p> <p>Flaring Tools 143 Soft Material Flaring Tools 143</p> <p>Flashlight D-Cell Flashlights 433 LED Flashlight Industrial Clamp Flashlight 431</p> <p>Flashlight Clamps 432</p>
--	--	--



<p>Flashlights 433 Bulbs Flashlights 433 Cordless Tool Flashlights 27, 58 Flashlights 433 Head Lanterns 432 Industrial Flashlights 430, 431 Mini Flashlights 433 Pen Light Flashlights 431 Safety Flashlights 431, 432</p> <p>Flat Chisels 95</p> <p>Flat Files 271</p> <p>Flat Plate Fittings 450, 451, 452</p> <p>Flat Saws 378</p> <p>Flat Washers 495</p> <p>Flex Handles 252, 254</p> <p>Flex Head Ratchets 249, 252</p> <p>Flexible Floodlights 21</p> <p>Flint Igniters 191</p> <p>Floats Bull Floats 390 Magnesium Floats 390 Rubber Floats 390</p> <p>Flood Lights 426</p> <p>Floodlights Flexible Floodlights 21</p> <p>Floor Brooms 613</p> <p>Floor Fans 365, 621</p> <p>Floor Lights 428</p> <p>Floor Protection 597, 598</p> <p>Floor Scrapers 392</p> <p>Floor Squeegees/Scrapers 614</p> <p>Floor Sweeping Compounds 615</p> <p>Flow Couplers 225</p> <p>Fluids Cutting Fluids 96 Metal Cutting Fluids 96, 97</p> <p>Flush Cut Blades 104</p> <p>Foam Filter Oil 387</p> <p>Foams Insulating Foams 583, 588</p> <p>Folding Ladders 208</p> <p>Folding Rules 142, 419</p> <p>Folding Screwdrivers 276</p> <p>Foot Switches 176</p> <p>Forced Air Kerosene Forced Air 368, 617</p> <p>Fork Meters 45</p> <p>Forks Concrete Rakes 284</p> <p>Forms Concrete Forms 398</p>	<p>Fractional Sockets 245, 246, 247, 248, 249, 250, 251, 254</p> <p>Fractional/Metric Sockets 245</p> <p>Frames Roller Frames 614</p> <p>Framing Hammers 277</p> <p>Framing Nails 534, 537, 538</p> <p>Framing Squares 415</p> <p>Framing Staplers 540</p> <p>Freeze Tools Pipe Freeze Tools 144</p> <p>Fresno Trowels 394</p> <p>Fuel Cartridges 542, 544</p> <p>Fuel Cell 541 Fuel Cell 541</p> <p>Fuel Cells 539, 541</p> <p>Fuel Packs 542</p> <p>Fuel Powered Nailers 535, 536</p> <p>Fuel Powered Staplers 539</p> <p>Full Body Harnesses 294, 295, 296, 302, 303, 304, 308</p> <p>Full Face Respirators 320</p> <p>G</p> <p>Galvanized Lanyards 298</p> <p>Galvanized Nails 541</p> <p>Galvanized Wire Cables 227</p> <p>Gardner Bender Conduit Benders 185 Fish Tapes 185 Hook-Type Sheaves 185 Hydraulic Knockouts 185 Power Tuggers 185 Wrench Knockouts 185</p> <p>Gas Compactors 395</p> <p>Gas Detector Docking Stations 313</p> <p>Gas Fasteners 542</p> <p>Gas Powered Saws 62, 373</p> <p>Gas Rammers 364, 395</p> <p>Gas Trowels 394</p> <p>Gasketed Fittings 453</p> <p>Geared Box Tool Sets 256, 257</p> <p>Geared Threader Shafts 139</p> <p>Geared Threaders 136</p> <p>Gearwrench See Apex</p> <p>General Purpose Faceshields 314</p> <p>Generator Accessories 350</p> <p>Generator Cord Adapters 435</p> <p>Generators Portable Generators 348, 349</p> <p>Genie Industries</p>	<p>Aerial Work Platforms 214</p> <p>Contractor Lifts 214</p> <p>Material Lifts 215, 216, 217</p> <p>Scissor Lifts 215, 216</p> <p>GFCI Cords 435</p> <p>Gilmour 606 Nozzles Accesories 606 Nozzles Accessories 606 Washers Accessories 606</p> <p>Glasses Copper Lens Glasses 318 Eyeglass Cases 317 Eyeglass Hang Cords 317 Mirror Lens Glasses 318 Safety Glasses 315, 316, 317 Smoke Lens Glasses 318</p> <p>Gliders Concrete Gliders 390 Electric Gliders 177</p> <p>Gloves Coated Gloves 323 Cotton Gloves 322 Driver Gloves 321 Fabric Gloves 322 Leather Gloves 321, 322 Plastic Gloves 322, 323 Rubber Gloves 323 Thermostat Gloves 322 Work Gloves 324, 325</p> <p>Goggles Safety Goggles 316, 317</p> <p>Golo Electric Winch 232</p> <p>Grabs Rope Grabs 299, 307</p> <p>Grain Scoops 288</p> <p>Grasshopper Carts 158</p> <p>Grating Interlock Grating 466, 467</p> <p>Greenlee Textron Inc. 170, 171, 172, 181, 182, 361, 362, 363, 364 Adapter Sheaves 176 Aluminum Hacksaws 161 Angle Protractors 173 Auger Bits 169 Battery-Powered CCX Tools 178 Battery-Powered Crimpers 180 Bending Shoe 172 Bending Shoe Groups 171, 172 Bending Tables 172 Bubble Levels 161 Cable Benders 181</p>
---	---	--



Cable Crimpers 181
Cable Cutters 179, 180
Cable Dispensers 183, 184
Cable Feeders 175
Cable Pullers 176
Cable Pulling Lubricants 177
Cable Strippers 181
Chain Saw 363
Chain Saws 363
Clamp-On Meters 182
Conduit Benders 172
Conduit Cutters 184
Conduit Dispensers 177
Conduit Pistons 175
Countersink Bits 166
Draw Studs 163, 165
Drill Bits 168, 169
Drive Punches 163
Driver Punches 161
Electric Gliders 177
Feeding Sheaves 176, 177
Fiberglass Repair Kit 173
Fish Lines 174
Fish Poles 174
Fish Stix 174
Fish Tapes 173, 174
Foot Switches 176
Hand Benders 170
Handy Caddies 183
Heater Benders 173
Heating Blankets 173
Hole Cutters 170
Hole Saws 170
Hook-Type Sheaves 176
Hydraulic 363, 364
Hydraulic Drive Punches 162
Hydraulic Drivers 161, 164, 165
Hydraulic Oils 184
Hydraulic Pumps 163, 165, 166, 184
Hydraulic Punches 164
Impact Bits 169
Keyhole Saws 169
Keyway Punches 166
Knockout Punches 162, 164, 165
Laser Levels 161
Manual Multimeters 182
Mechanical Benders 171
Mild Steel Punches 162
Offset Benders 170
Oiltight Punches 166
Poly Ropes 174
Power Bits 168

Power Fishing Systems 174, 175
Pulling Grips 169, 178
Punch Dies 165
PVC Cutters 161
PVC Heater/Benders 173
PVC Plugs 173
Ram and Hand Pumps 163
Ratchet Wrenches 163, 165
Reel Spindles 184
Reel Stands 184
Rod Cutters 184
Rope Clevis 177
Rope Stands 177
Step Bits 168
Storage Cabinets 182
Storage Racks 183
Stud Punches 166
Support Rollers 172
Tape Measures 177
Tube Benders 170
Utility Carts 183
Voltage Detectors 181
Water 363
Wire Caddies 183
Wire Carts 183
Wire Dispensers 183
Wire Strippers 161
Wood Boring Bits 169
Wrench Knockouts 163
Grinder
Concrete Grinder 80
Grinder Mandrels 571
Grinder Pads 36
Grinders
Angle Grinders 52, 58, 62, 63, 351
Bench Grinders 37
Cup Grinders 382
Die Grinders 53, 351
Dry Grinders 381
Electric Grinders 35, 36, 37, 53, 63, 69, 77
Grinders Cutting 52
Right Angle Grinders 19, 35
Variable-Speed Grinders 89
Grinders Cutting 52
Grinding Wheels 570, 571, 572
Grips
Pulling Grips 169, 178
Wire Rope Grips 224
Grommets
Firestop Grommets 577
Groovers

Concrete Groovers 391
Roll Groovers 141
Walking Groovers 390
Ground Rod Cables 190
Ground Rod Chisels 95
Ground Rod Drivers 361
Grounding Ferrules 228
Grounding Weld Metals 189
Grout
Grout Removal 74
Grout Removal 74
Guardian Fall Protection 309, 311
Anchor Strap 310
Beam Anchors 311
Brackets Roof 213
Concrete Grip Anchor 310
Fall Protection Kit 310
Full Body Harnesses 308
Ladder Safety 311
Retractable Cable 309
Retractable Lifeline 309, 310
Retractable Lifelines 309
Retrieval Kit Rescue 310
Roof Anchors 311
Rope Lifeline 310
Shock Absorbing Lanyards 309
Stabilizer Ladder 207, 311
Steel Pump Jacks 212, 213
Tool Lanyard 309
Wall Jacks 213
Guards
Discs Guards 53
Lighting Guards 429
Guide
Magnetic Screw Guide 118
Gun Nails 541
Guns
Blow Guns Guns 608
Caulk Guns 20, 48, 583, 584
Heat Guns 46, 55, 70
Soldering Guns 143
Staple Guns 281
H
Hack Saws 79
Half Mask Respirators 320
Half Round Files 271
Halogen, Quartz Light Bulb 429
Hammer Bits 100, 101
Hammer Drill Kits 40, 56
Hammer Drills
Cordless Hammer Drills 56



<p>Electric Hammer Drills 50, 68</p> <p>Hammer Holders 343</p> <p>Hammer Kits 24</p> <p>Hammer Tackers 280, 281</p> <p>Hammerdrill Bits 94</p> <p>Hammerdrill Kits 23</p> <p>Hammerdrills</p> <p> Cordless Hammerdrills 47</p> <p> Electric Hammerdrills 30, 68</p> <p>Hammers</p> <p> Air Hammers 350</p> <p> Ball Pein Hammers 278, 289</p> <p> Brass Hammers 290</p> <p> Chipping Hammers 356</p> <p> Construction Hammers 279</p> <p> Cross Pein Hammers 289</p> <p> Dead Blow Hammers 289</p> <p> Double Face Hammers 278</p> <p> Drywall Hammers 391</p> <p> Electrician Hammers 278</p> <p> Fiberglass Hammers 278</p> <p> Framing Hammers 277</p> <p> Pick Hammers 358</p> <p> Pistol Grip Hammers 350</p> <p> Rip Hammers 277, 278</p> <p> Rotary Hammers 19, 33, 34, 47, 80</p> <p> Sledge Hammers 288, 289, 290</p> <p> Split-Head Hammers 279</p> <p> Steel Hammers 277</p> <p> Titanium Hammers 278</p> <p> Tubular Steel Hammers 278</p> <p>Hammers 290</p> <p>Hammer-Screw Anchors 518</p> <p>Hand Benders 170</p> <p>Hand Cleaner 590</p> <p> Hand Cleaner 590</p> <p>Hand Lamps 436</p> <p>Hand Pads 567</p> <p>Hand Pipe 130</p> <p>Hand Pumps 226, 227, 240</p> <p>Hand Riveters 282</p> <p>Hand Sanitizer 334</p> <p> Hand Sanitizer 334</p> <p>Hand Soaps 590</p> <p>Hand Trucks</p> <p> Industrial Hand Trucks 230</p> <p>Hand Wipes 590</p> <p>Handle</p> <p> Sliding T Handles 254</p> <p>Handle Clamps 191</p> <p>Handles</p> <p> Aluminum Handles 391</p>	<p>Aluminum Handles 391</p> <p>Broom Handles 613</p> <p>File Handles 272</p> <p>Flex Handles 252, 254</p> <p>Hinge Handles 250</p> <p>Pole Sander Handles 391</p> <p>Replacement Handles 292</p> <p>Round Point Shovels 290</p> <p>Speeder Handles 250, 252</p> <p>Square Point Shovels 291</p> <p>T-Handles 250, 252</p> <p>Trowel Handles 391</p> <p>Wood Handles 391</p> <p>Handy Caddies 183</p> <p>Hanger Bolts 493</p> <p>Hanger Connectors 462</p> <p>Hangers</p> <p> Box Hangers 489</p> <p> Clevis Hangers 466</p> <p> Conduit Hangers 490</p> <p> Light Fixture Hangers 491</p> <p> Rod and Wire Hangers 491</p> <p> Rod Hangers 489</p> <p> Swivel Hangers 463</p> <p> Truss Hangers 552</p> <p> Wire Hangers 491</p> <p>Hard Hat Sweatbands 314, 315</p> <p>Hard Hats 313</p> <p>Hardener</p> <p> Concrete Hardener 400</p> <p>Harness</p> <p> Fall Protection Kit 304</p> <p>Harness Accessories 302</p> <p> Trauma Safety Strap 304</p> <p>Harness Accessory Kits 302</p> <p>Harness Back Pad 304</p> <p>Harness Belt 303, 304</p> <p>Harness Connection Points 303</p> <p>Harness Identification Kits 303</p> <p>Harness Pads 303</p> <p>Harness 310</p> <p>Harnesses</p> <p> All-Purpose Harnesses 295</p> <p> Construction Harnesses 295</p> <p> Full Body Harnesses 294, 295, 296, 302, 303, 304, 308</p> <p> Safety Harnesses 296</p> <p> Vest Harnesses 294</p> <p>Hatch</p> <p> Roof Access Hatch 605</p> <p>Hats</p> <p> Hard Hats 313</p>	<p>Hawks</p> <p> Aluminum Hawks 391</p> <p>Head Lanterns 432</p> <p>Head Shears 76</p> <p>Headgears</p> <p> Safety Headgears 316</p> <p>Heads</p> <p> Die Heads 140</p> <p> Vibrator Heads 395</p> <p>Headsets Radios 334</p> <p>Hearing Bands 319</p> <p>Heat Guns 46, 55, 70</p> <p>Heater Benders 173</p> <p>Heaters</p> <p> Milkhouse Heaters 366, 616</p> <p> Radiant Heaters 366, 616</p> <p>Heaters/Benders</p> <p> PVC Heater/Benders 173</p> <p>Heating Blankets 173</p> <p>Heatstar/Enerco</p> <p> Convection 369, 616</p> <p> Kerosene 369</p> <p> Propane 368, 369</p> <p> Tank-top Propane 370, 616</p> <p>Heavy Duty Degreasers 589</p> <p>Heavy Duty Shears 122</p> <p>Heavy Moving Rollers 229</p> <p>Helly Hansen 328, 329</p> <p> Bibs Rain Gear 330</p> <p> Jackets Clothing 329</p> <p> Jackets Rain Gear 330</p> <p>Hepa Vacuums 84</p> <p>Hex Bit Holders 121</p> <p>Hex Bits 120, 121</p> <p>Hex Bolts 493</p> <p>Hex Drive Nutsetters 122</p> <p>Hex Insert Bits 120, 121</p> <p>Hex Keys 275, 276, 277</p> <p>Hex Nuts 449, 494</p> <p>Hex Sockets 246, 248, 249, 251</p> <p>Hex Wrench 126</p> <p>Hickeys</p> <p> Rebar Hickeys 204</p> <p>High Speed Saw Blades 381</p> <p>High Speed Steel Taps 273</p> <p>High Test Chains 228</p> <p>High-Capacity Chests 233</p> <p>Hilman, Inc.</p> <p> Heavy Moving Rollers 229</p> <p> Rigger Kits 229</p> <p> Toe Jacks 229</p> <p>Hinge Fittings 459, 460</p>
--	--	---

<p>Hinge Handles 250</p> <p>Hinged Cutters 151</p> <p>Hi-Vis Vests 296</p> <p>Hoes</p> <ul style="list-style-type: none"> Mortar Hoes 285 <p>Hoists</p> <ul style="list-style-type: none"> Chain Hoists 220 Lever Cable Hoists 224 Lever Hoists 218, 219 <p>Hold Downs</p> <ul style="list-style-type: none"> Pipe Hold Downs 157 <p>Holders</p> <ul style="list-style-type: none"> Bull Pin Holders 202 Cell Phone Holders 343 Crayon Holders 424 Disc Holders 566 Erection Wrench Holders 202 Hammer Holders 343 Hex Bit Holders 121 Tape Rule Holders 343 Tool Holders 202, 343 <p>Holdowns</p> <ul style="list-style-type: none"> Strap Tie Holdowns 550 Tension Holdowns 550 <p>Hole Cover 160, 387</p> <ul style="list-style-type: none"> Hole Cover 160, 387 <p>Hole Cutters 119, 125, 170</p> <ul style="list-style-type: none"> Electric Hole Cutters 142 <p>Hole Saws 106, 107, 108, 109, 170, 380</p> <ul style="list-style-type: none"> Hole Saws 108 <p>Hollow Wall Anchor 520</p> <p>Honeywell 312</p> <ul style="list-style-type: none"> Cleaning Wipes 321 Coated Gloves 323 Eyewash Bottle Eyewash 334 Full Face Respirators 320 Gas Detector Docking Stations 313 Half Mask Respirators 320 Multigas Detectors 312 Respirator Accessories 321 Rubber Gloves 323 Station Eyewash 334 <p>Hook & Loop Discs 567</p> <p>Hookaroons</p> <ul style="list-style-type: none"> Wood Handle Hookaroons 371 <p>Hooks</p> <ul style="list-style-type: none"> Carabiner Hooks 300 <p>Hook-Type Sheaves 176, 185, 186</p> <p>Horizontal Conductors 191</p> <p>Horizontal Splices 191</p> <p>Hoses</p>	<p>Vacuum Hoses 86</p> <p>Hougen MFG., Inc. 80, 81, 83</p> <ul style="list-style-type: none"> Annular Cutters 82 Hole Cutters 119, 125 Magnetic Drills 81 <p>Howard Leight by Honeywell</p> <ul style="list-style-type: none"> Disposable Earplugs 318, 319 Hearing Bands 319 Reusable Earplugs 318, 319 Safety Earmuffs 319, 320 <p>HP Routers 91</p> <p>Husqvarna</p> <ul style="list-style-type: none"> 2-Stroke Engine Engine Oil 386 Abrasive Blades 382, 383 Blades 376 Concrete Cutting Saws 375 Concrete Saws 377, 378 Core Bits 387 Cored Bits 386 Cup Wheels 382 Cutoff Saws 374, 375 Diamond Blades 383, 384, 385, 386 Diamond Discs 385 Extension Shafts 383 Flat Saws 378 Foam Filter Oil 387 Porta Saws 376 Saw Blades 376 Shaft Adapters 383 Tile Blades 385, 386 Tuckpoint Blades 383, 384 Wet Cutting Kits 375 <p>Hybrid Saws 88</p> <p>Hydraulic 363, 364</p> <ul style="list-style-type: none"> Hydraulic 363, 364 <p>Hydraulic Crimpers 187</p> <p>Hydraulic Cutters 187</p> <p>Hydraulic Cylinders 226</p> <p>Hydraulic Drive Punches 162</p> <p>Hydraulic Drivers 161, 164, 165</p> <p>Hydraulic Knockouts 185</p> <p>Hydraulic Oils 184, 226</p> <p>Hydraulic Pumps 163, 165, 166, 184</p> <p>Hydraulic Punches 164</p> <p>Hydraulic Tool Sets 226</p> <p>Hydrostatic</p> <ul style="list-style-type: none"> Test Hydrostatic 152 <p>Hypoid Saws 61</p> <p>I</p> <p>I-Beam Levels 414</p> <p>Ideal Industries</p>	<p>Cable Cutters 122</p> <p>Identification Kits</p> <ul style="list-style-type: none"> Harness Identification Kits 303 <p>Ignitors</p> <ul style="list-style-type: none"> Flint Ignitors 191 <p>Impact Bits 169</p> <p>Impact Drive Adapters 254, 255, 256</p> <p>Impact Driver Kits 23</p> <p>Impact Drivers 18, 41, 43, 56, 57</p> <p>Impact Extensions 253, 255</p> <p>Impact Sockets 247, 248, 253, 255</p> <p>Impact Wrench Kits 41</p> <p>Impact Wrenches 18, 26, 27, 32, 33, 47, 52, 57, 62, 350</p> <p>Industrial Connectors 436</p> <p>Industrial Flashlights 430, 431</p> <p>Industrial Hand Trucks 230</p> <p>Industrial Lanterns 430</p> <p>Industrial Plugs 436</p> <p>Industrial Shovels 291</p> <p>Industrial Thermo Polymers</p> <ul style="list-style-type: none"> Backer Rod 398 <p>Industrial Tilt Truck 231</p> <p>Industrial-Duty Adapters 436</p> <p>Industrial-Duty Outlet Box 436</p> <p>Industrial-Duty Reels 437</p> <p>Industrial-Duty Sockets 436</p> <p>Inhibitors</p> <ul style="list-style-type: none"> Corrosion Inhibitors 585 <p>In-Line Lubricators 609</p> <p>Inner/Outer Reamers 135</p> <p>Insect Insecticides 587</p> <p>Insecticides</p> <ul style="list-style-type: none"> Insect Insecticides 587 <p>Inserts</p> <ul style="list-style-type: none"> Concrete Inserts 464 <p>Inspection Cameras 145, 146</p> <p>Inspection Mirrors 260</p> <p>Installer Bits 117</p> <p>Insulating Foams 583, 588</p> <p>Interchangeable Bit Screwdrivers 117</p> <p>Interlock Grating 466, 467</p> <p>Internal Wrenches 127</p> <p>Intumescent Sealants 575</p> <p>Inverted Aerosol Markers 422, 586</p> <p>Irrigation Shovels 286</p> <p>Irwin Industrial Tools 263, 264</p> <ul style="list-style-type: none"> Aviation Snips 265 C Clamps 262, 263 Carpenter Pencils 424, 603 Chalk Lines 422, 423
--	--	--



<p>Circular Saw Blades 110 Installer Bits 117 Interchangeable Bit Screwdrivers 117 Locking Pliers 263 Magnetic Screw Guide 118 Offset Snips 265 Pencil Sharpener 424, 603 Plier Parts 264 Portable Labelers 604 Refill Chalks 423 Rhino Labels 604 Sharpie Markers 424, 425, 604 Sheet Metal Clamps 263 Socket Extensions 118 Spade Bits 116 Tinner Snips 266 Utility Knife Blades 271 Utility Knives 270, 271 Welding Clamps 263 Wood Bit Extensions 117 Wood Bits 117 Woodboring Bits 117</p> <p>J Jab Saws 292 Jacket Jackets Parkas 327 Reflective Jacket 327 Jackets Clothing 329 Jackets Parkas 327 Jackets Rain Gear 330 Jacks Ladders Jacks 207 Pipe Jacks 156, 157 Steel Pump Jacks 212 Toe Jacks 229 Wall Jacks 213 Jacks 230 Jackson Safety 618 Bump Caps 314 Delineator Posts 331 Drybrow Sweatbands 314 Erosion Control Fences 399 Faceshield Brackets 314 Faceshield Windows 316 General Purpose Faceshields 314 Hard Hat Sweatbands 314 Hard Hats 313 Parking Curbs 331 Pennant Flags 331 Plastic Fences 399</p>	<p>Polypropylene Sandbags 331 Protector Rebar Caps 397 Rebar Protector Caps 396 Replacement Pinlock 314 Replacement Ratchet 314 Safety Glasses 315, 316 Safety Goggles 316 Safety Headgears 316 Safety Shirts 326 Safety Vests 326 Speed Bumps 331 Traffic Cones 330 Traffic Paddles 331 Warning Flags 331 Weighted Base Triangle Kits 331 Wheel Chocks 331 Winter Liners 314, 617, 618</p> <p>Jenny Air Compressors 345</p> <p>Jetters Drain Cleaners 148</p> <p>Jiffy Mixer 388</p> <p>Jig Kits Dovetail Jigs 91</p> <p>Jig Saw Blades 105</p> <p>Jig Saws 19, 28, 58, 68</p> <p>Job Site Radios 65</p> <p>Jobber Drills 111, 112, 114, 115, 116</p> <p>Jobbox High-Capacity Chests 233 Liquid Transfer Boxes 234 Storage Cabinets 234 Tool Cabinets 233 Tool Chest Trays 235 Tool Chests 232, 233 Vehicle Underbed Boxes 234 Work Benches 234</p> <p>Jobsite Radios 67</p> <p>Joiner Crimping Tools Joiner 155</p> <p>Joiners Channel Joiners 463 Electric Joiners 40 Plate Joiners 91</p> <p>Joining Biscuits 91</p> <p>Joint Covers 464</p> <p>Joint Water Stops 409 Joint Water Stops 409</p> <p>Jointers Professional Jointers 88</p> <p>Joints Universal Joints 250, 253, 254, 255</p>	<p>Joist 552 Joist 552</p> <p>Joist Drills 31</p> <p>Joist Hanger Nails 534</p> <p>K Kerf Saw Blades 66 Kerosene 369 Kerosene 369 Kerosene Forced Air 368, 617 Keson Industries Measuring Wheels 416, 417 Tape Measures 416 Kett Tool Company Double-Cut Shears 75 Electric Nibbler Attachment 76 Electric Shears 76 Head Shears 76 Kits Shears 77 Panel Saws 75 Pistol Grip Shears 75 Replacement Blades Shears 76, 77 Saw Blades 76 Scissor Head Shears 76 Variable Speed Shears 75, 76</p> <p>Keyhole Saws 169</p> <p>Keyleashes Chuck Keyleashes 124</p> <p>Keyless Drill Chucks 123</p> <p>Keys Chuck Keys 123 Hex Keys 275, 276, 277 Valve Keys 153</p> <p>Keyway Punches 166</p> <p>Kidde Fyrnetics Fire Extinguishers 336</p> <p>Kimberly-Clark Cleaning Wipes 590 Hand Wipes 590 Protective Coveralls 330 Reinforced Wipers 590 Towel Wipers 330</p> <p>Kit 335, 615 Blade Kit 124 Kit 335, 615 Safety Kit 335, 615 Wet Cutting Kits 375</p> <p>Kits 25-Person Kits 332 4-Tool Kits 24 5-Tool Kits 24 Double-Cut Shears 75</p>
--	---	---

<p>Drill Driver Kits 44</p> <p>Drill/Driver Kits 17, 23</p> <p>Drivers Kits 24</p> <p>Hammer Drill Kits 56</p> <p>Hammer Kits 24</p> <p>Hammerdrill Kits 23</p> <p>Impact Driver Kits 23</p> <p>Impact Wrench Kits 41</p> <p>Pistol Grip Shears 75</p> <p>Rigger Kits 229</p> <p>Saw Kits 24, 42</p> <p>Variable Speed Shears 75</p> <p>Kits Multi-Tools 44</p> <p>Kits Shears 77</p> <p>Kleen Break Telespar 593</p> <p>Klein Tools</p> <p>11-in-1 Screwdrivers 200</p> <p>Adjustable Wrenches 201, 262</p> <p>Bull Pin Holders 202</p> <p>Bull Pins 204</p> <p>Cable Cutters 197</p> <p>Cable Splicers 203</p> <p>Cable Strippers 198</p> <p>Conduit Reamers 203</p> <p>Connecting Bars 204</p> <p>Cushion Grip Screwdrivers 199, 200</p> <p>Cushion-Grip Screwdrivers 199, 200</p> <p>Cutter Pliers 195, 196</p> <p>Cutting Pliers 194, 195</p> <p>Diagonal Cutters 197</p> <p>Drift Pins 204</p> <p>Electrician Snips 203</p> <p>Electrode Bags 202</p> <p>End-Cutting Pliers 195</p> <p>Erection Wrench Holders 202</p> <p>Erection Wrenches 201</p> <p>Folding Screwdrivers 276</p> <p>Hex Keys 275</p> <p>Long Nose Pliers 195, 196</p> <p>Nut Drivers 200, 201</p> <p>Ratcheting Wrenches 201</p> <p>Rebar Hickeys 204</p> <p>Replacement Taps 203</p> <p>Round Shank Screwdrivers 200</p> <p>Scratch Awls 203</p> <p>Set Screwdrivers 199, 200</p> <p>Side Cutters 195, 196, 197</p> <p>Slip Joint Pliers 196</p> <p>Terminal Crimpers 198</p> <p>Thread Tapping Tools 203</p> <p>Tie-Wire Reels 203</p> <p>Tool Bars 204</p>	<p>Tool Buckets 201, 202</p> <p>Tool Holders 202</p> <p>Tool Pouches 202</p> <p>Wire Crimpers 198</p> <p>Wire Reel Pads 203</p> <p>Wire Strippers 197, 198</p> <p>KNAACK Jobsite Storage</p> <p>Equipment 236, 240</p> <p>Portable Worktables 237</p> <p>Storage Cabinets 235, 237</p> <p>Tool Boxes 236</p> <p>Tool Chests 235, 236</p> <p>Vehicle Chests 235</p> <p>Welders Boxes 235</p> <p>Work Benches 236</p> <p>Knee Pads 337, 338</p> <p>Knife Blades 270</p> <p>Knife Files 271</p> <p>Knives</p> <p>Pocket Knives 269</p> <p>Putty Knives 269</p> <p>Retractable Blade Knives 269</p> <p>Snap Off Knives 269</p> <p>Taping Knives 391</p> <p>Utility Knives 269, 270, 271</p> <p>Knockout Punches 162, 164, 165</p> <p>Knockouts</p> <p>Hydraulic Knockouts 185</p> <p>Wrench Knockouts 163, 185</p> <p>Krylon 586, 587</p> <p>Krylon Industrial Paints 586</p> <p>Acrylic Enamel Aerosols 585</p> <p>Inverted Aerosol Markers 422, 586</p> <p>Krypton Bulbs 431</p> <p>L</p> <p>L.B. White 368, 617</p> <p>Kerosene Forced Air 368, 617</p> <p>Labelers</p> <p>Portable Labelers 604</p> <p>Labels</p> <p>Rhino Labels 604</p> <p>Ladder</p> <p>Ladder Safety 311</p> <p>Stabilizer Ladder 207, 311</p> <p>Ladder Climbing Safety Systems</p> <p>308</p> <p>Ladder Guards 207</p> <p>Ladder Levelers 207</p> <p>Ladder Locks 207</p> <p>Ladder Safety 311</p> <p>Ladder Shoes 207</p>	<p>Ladder Stabilizer 207</p> <p>Ladder Stabilizers 206</p> <p>Ladders</p> <p>Extension Ladders 205, 206</p> <p>Folding Ladders 208</p> <p>Leveler Ladders 208</p> <p>Multipurpose Ladders 208</p> <p>Step Ladders 205</p> <p>Tripod Ladders 206</p> <p>Twin Front Ladders 205</p> <p>Wall Standoff Ladders 208</p> <p>Ladders Jacks 207</p> <p>Lag Bolts 494</p> <p>Laminate Trimmers 90, 91</p> <p>Laminated Steel Padlocks 602</p> <p>Lamp Lights 429</p> <p>Lamps</p> <p>Hand Lamps 436</p> <p>Landscape Rakes 285</p> <p>Lanterns</p> <p>Industrial Lanterns 430</p> <p>Lanyard</p> <p>Tool Lanyard 304, 309</p> <p>Lanyards</p> <p>Chain Lanyards 298</p> <p>Galvanized Lanyards 298</p> <p>Safety Lanyards 297, 305</p> <p>Shock Absorbing Lanyards 296, 297, 304, 305, 309</p> <p>Wall-Form Lanyards 298</p> <p>Web Lanyards 304</p> <p>Laser</p> <p>Dectector Laser 411</p> <p>Distance Lasers 46</p> <p>Layout Target Laser 411</p> <p>Laser Drill Presses 88</p> <p>Laser Floor Stand 412</p> <p>Laser Level Cases 415</p> <p>Laser Levels 161, 415, 416</p> <p>Laser Plumb Level 410, 411, 412</p> <p>Lasers</p> <p>Alignment Lasers 410</p> <p>Cordless Lasers 412</p> <p>Palm Lasers 410</p> <p>Lasers Measures 422</p> <p>Lathes</p> <p>Variable-Speed Lathes 88</p> <p>Lawn Rakes 285</p> <p>Layout Target Laser 411</p> <p>Leaders</p> <p>Fish Tapes 173, 174</p> <p>Leaktite Corp.</p>
--	--	---



<p>Bucket Liners 612 Pail Strainers 612 Plastic Buckets 612 Polysteel Buckets 612 Leather Belts 343 Leather Gloves 321, 322 Leather Suspenders 344 Leatherman Leatherman Multi-Tools 266, 267, 268 Leatherman Multi-Tools 266, 267, 268 LED Flashlight Industrial Clamp Flashlight 431 Leisure Craft Inc. Benches 622 Perforated Benches 622 Perforated Tables 622 Lens Cleaners 317 Level 90½ Laser Level 411 Laser Plumb Level 410, 411, 412 Leveler Ladders 208 Levelers Ladder Levelers 207 Levels Bubble Levels 161 Electronic Levels 413 Extendable Levels 413 I-Beam Levels 414 Laser Levels 161, 415, 416 Magnetic Levels 413, 414 Masonry Levels 414 Plate Levels 413 Torpedo Levels 413, 414, 415, 416 Lever Benders 143 Lever Cable Hoists 224 Lever Hoists 218, 219 Lifeline Retractable Lifeline 309, 310 Lifelines Portable Horizontal Lifelines 299 Retractables Lifelines 309 Rope Lifelines 307 Safety Lifelines 299 Self - Retracting Lifelines 298, 299 Self Retracting Lifelines 298, 306 Lifelines 308 Lift-All Endless Slings 218 Ratchet Tie Downs 217 Tow Straps 218</p>	<p>Web Slings 217 Lifts Contractor Lifts 156, 214 Material Lifts 155, 215, 216, 217 Scissor Lifts 215, 216 Light Bulb Halogen, Quartz Light Bulb 429 Light Bulbs 426 Light Bulbs Lighting 429 Light Fixture Clips 489 Light Fixture Hangers 491 Light Strings Temporary Light Strings 429 Lighters Spark Lighters 159 Lighting Area Lighting 433 Light Bulbs Lighting 429 Work Light Lighting 43 Lighting Guards 429 Lights Clamp Lights 429 Flood Lights 426 Floor Lights 428 Lamp Lights 429 Shop Lights 429 Task Lights 428 Work Lights 48, 426, 428 Limiter Self-Retracting Limiter 306 Limiters Self-Retracting Limiters 306 Line Reels 423 Linemen's Pliers 262 Liners Bucket Liners 612 Winter Liners 314, 617, 618 Lines Chalk Lines 422, 423 Fish Lines 174 Links Quick Links 223 Liquid Transfer Boxes 234 Lithium-Ion Batteries 21, 42, 48, 59, 60, 66 Load Binders Ratchet Load Binders 228 Loadbinders Carbon Hook Loadbinders 229 Loads Powder Loads 547 Lobular Opening Sockets 255</p>	<p>Locators Utility Locators 146 Lock Nuts 494 Lock Washers 449, 495 Lockers Ventilated Lockers 622 Locking Pliers 263 Lockout Tags 603 Lockouts Lockout Tags 603 Security Lockouts 603 Locks Cable Padlocks 603 Combination Padlocks 603 Laminated Steel Padlocks 602 Long Handle Ratchets 252 Long Nose Pliers 195, 196 Long Pattern Wrenches 259 Louisville Ladder Corp. Extension Ladders 205, 206 Ladder Guards 207 Ladder Levelers 207 Ladder Locks 207 Ladder Shoes 207 Ladder Stabilizer 207 Ladder Stabilizers 206 Step Ladders 205 Telescoping Planks 206 Tripod Ladders 206 Twin Front Ladders 205 Lubricants Cable Pulling Lubricants 177 Cutting Lubricants 587 Multi-Purpose Lubricants 590 Spray Lubricants 591 Lubrication Oil Cordless Tool 539 Lubricators Air Tool Lubricators 609 In-Line Lubricators 609 Lug-All Corporation Lever Cable Hoists 224 Lumber Crayons 423 M M K Morse 78 Arbors 109 Band Saw Blades 110 Carbon Steel Arbors 107 Circular Saw Blades 78 Hole Saws 106, 107, 108, 109 Pilot Bits 109 Pilot Drills 109</p>
---	--	---

Saw Circular 77	Impact Drivers 56, 57	Soapstone Markers 424
Step Bits 118	Impact Wrenches 57, 62	Marshalltown Trowel Co.
Machines	Jig Saws 58	Acid Brushes 389
Cut-Off Machines 55, 69	Job Site Radios 65	Aluminum Handles 391
Prep Machines 132	Kerf Saw Blades 66	Aluminum Handles 391
Roll Grooving Machines 142	Lithium-Ion Batteries 59, 60, 66	Aluminum Hawks 391
Threading Machines 138, 139	Metal Cut Saws 57	Bricklaying Trowels 393
Machinist's Files 271	Miter Saws 60	Bucket Brushes 389
MAG-BIT	NiCad Batteries 65	Bull Floats 390
Bit Extensions 118	Ni-CD Batteries 66	Concrete Brooms 388
Steel Bits 118	Ni-MH Batteries 65, 66	Concrete Darbies 389
MagLite	NiMH Batteries 65	Concrete Edgers 389, 390
Bulbs Flashlights 433	Reciprocating Saws 57, 60	Concrete Gliders 390
D-Cell Flashlights 433	Saw Blades 66	Concrete Groovers 391
Flashlights 433	Steel Saw Blades 66	Concrete Placers 392
Mini Flashlights 433	Table Saws 60	Concrete Pulls 392
Magnesium Floats 390	Wheel Sanders 64	Concrete Tampers 392
Magnesium Screeds 392	Malco Products Inc.	Drywall Hammers 391
Magnetic Drills 80, 81	Fiber Cement Shears 122	Drywall Mixers 392
Magnetic Levels 413, 414	Heavy Duty Shears 122	Finishing Trowels 393
Magnetic Protractors 414	Metal Shears 122	Floor Scrapers 392
Magnetic Screw Guide 118	Mallets	Fresno Trowels 394
Magnetic Seepwers 614	Rubber Mallets 278	Magnesium Floats 390
Magnetic Worklight 429	Rubber Mallets 290	Magnesium Screeds 392
Maintenance Cleaners 587	Mandrels	Margin Trowels 393, 394
Majestic Glove 324	Grinder Mandrels 571	Masonry Brushes 389
Makita USA 62	Manhole Hooks Municipal Castings	Midget Trowels 393
Air Compressors 347, 348	152	Notched Trowels 394
Angle Grinders 58, 62, 63	Manifold Pumps 227	Pole Sander Handles 391
Band Saws 57, 64	Manifolds	Rub Bricks 388
Battery Chargers 65	Tee Manifolds 609	Rubber Floats 390
Belt Sanders 64	Tri-Pod Manifolds 609	Square Ornamental Trowels 393
Chop Saws 64	Manila Rope 194, 611	Step Tools 393
Circular Saws 61	Manual Multimeters 182	Taping Knives 391
Concrete Planers 65	Manual Tackers 281	Trowel Handles 391
Cordless Combo Kits 58, 59, 60	Marathon Industries	Walking Groovers 390
Cordless Concrete Vibrators 59	Wheelbarrow Tires 371	Wood Handles 391
Cordless Drill/Drivers 57	Margin Trowels 393, 394	Marson
Cordless Driver Drills 56	Marinco LLC	Hand Riveters 282
Cordless Hammer Drills 56	Cord Plugs 435	Masking Tapes 599
Cordless Tool Flashlights 58	Markal	Mason Twine 194, 611
Electric Breaker Hammers 62	Crayon Holders 424	Masonry Anchors 514
Electric Demolition Hammers 62	Felt Tip Markers 424	Masonry Bits 98, 99, 100
Electric Drills 58, 61	Lumber Crayons 423	Masonry Brushes 389
Electric Grinders 63	Paint Markers 424	Masonry Levels 414
Electric Planers 64	Paint Multi Surface 424	Masonry Saw Blades 381
Electric Rotary Hammers 62	Soapstone Markers 424	Masonry Saws 373
Electric Sanders 63, 64	Markers	Master Lock Co.
Electric Shears 65	Felt Tip Markers 424	Cable Padlocks 603
Gas Powered Saws 62	Paint Markers 424	Combination Padlocks 603
Hammer Drill Kits 56	Paint Multi Surface 424	Laminated Steel Padlocks 602
Hypoid Saws 61	Sharpie Markers 424, 425, 604	Lockout Tags 603



<p>Security Lockouts 603 Universal Padlocks 602 Material Lifts 155, 215, 216, 217 Material Scrapers 286 Mats Anti-Fatigue Mat 336, 337 Mattocks Pick Mattocks 285 Measurements Digital Multimeters 45 Measures Lasers Measures 422 Tape Measures 416, 417, 418, 419 Measuring Tapes 418 Measuring Wheels 416, 417 Mechanical Benders 171 Mechanics Vises 283 Medium Crown Staples 535 Memphis Glove Cotton Gloves 322 Driver Gloves 321 Fabric Gloves 322 Leather Gloves 321, 322 Plastic Gloves 322, 323 Rubber Gloves 323 Thermastat Gloves 322 Metabo Corporation 77 Electric Grinders 77 Metal Cut Saws 57 Metal Cutting Blades 109 Metal Cutting Fluids 96, 97 Metal Sammys 524 Metal Shears 122 Meters Clamp Meters 46 Clamp-On Meters 182 Fork Meters 45 Metric Sockets 246, 247 Microphones Radio Microphones 334 Midget Combination Wrench 257 Midget Trowels 393 Midwest Tool & Cutlery Aviation Snips 265 Mighty Tie Cable Ties Cable Management 611 Mild Steel Punches 162 Milkhouse Heaters 366, 616 Mill Files 272 Miller by Honeywell Cable Connector Portable/Temp Anchorage Connectors 308</p>	<p>Carabiner Temporary Anchorage Connectors 308 Concrete Grip Anchor 307 Cross-Arm Strap Portable/Temp Anchorage Connectors 307 Fall Protection Kit 304 Full Body Harnesses 302, 303, 304 Harness Accessories 302 Harness Accessory Kits 302 Harness Back Pad 304 Harness Belt 303, 304 Harness Connection Points 303 Harness Identification Kits 303 Harness Pads 303 Ladder Climbing Safety Systems 308 Rebar Positioning Assembly 305 Rescue/Retrieval Systems 308 Roof Anchors 307 Roof Anchors Permanent 308 Rope Grabs 307 Rope Lifelines 307 Safety Lanyards 305 Self Retracting Lifelines 306 Self-Retracting Arrestor 306 Self-Retracting Limiter 306 Self-Retracting Limiters 306 Shock Absorbing Lanyards 304, 305 Tool Lanyard 304 Trauma Safety Strap 304 Web Lanyards 304 Wire Hook Portable/Temp Anchorage Connectors 307 Milwaukee Electric Tool Corp. Angle Grinders 52 Band Saw Kits 42 Band Saws 48, 54 Bare Expansion Tools 42 Batteries Cordless 47 Battery Chargers 43, 47 Battery Cordless 47 Caulk Guns 48 Chargers Batteries 43 Circular Saws 43, 47, 49, 55 Clamp Meters 46 Contractor Bits 111 Cordless Combo Kits 48 Cordless Drill/Drivers 41 Cordless Hammerdrills 47 Cordless Tool Batteries 43, 48 Cut-Off Machines 55 Cut-Off Saws 55</p>	<p>Detection Tool Kits 45 Die Grinders 53 Digital Cameras 47 Digital Multimeters 45 Discs Guards 53 Distance Lasers 46 Drill Driver Kits 40, 44 Drive Extensions 56 Electric Drills 49, 50, 51, 54 Electric Files 53 Electric Grinders 53 Electric Hammer Drills 50 Electric Nibblers 55 Electric Polishers 53 Electric Screwdrivers 51 Electric Shears 55 Electromagnetic Drill Presses 54 Electromagnetic Drills 54 Expansion Tool Kits 41, 45 Flush Cut Blades 104 Fork Meters 45 Grinders Cutting 52 Hammer Drill Kits 40 Heat Guns 46, 55 Impact Drivers 41, 43 Impact Wrench Kits 41 Impact Wrenches 47, 52 Jig Saw Blades 105 Kits Multi-Tools 44 Lithium-Ion Batteries 42, 48 Plumbers Bits 111 R.A.D. Assemblies 56 Reciprocating Saw Blades 102 Reciprocating Saws 45, 48, 49 Right Angle Attachments 55 Right Angle Drills 51 Rotary Hammers 47 Saw Kits 42 Sawzall Blades 102, 103, 104 Self-feed Bits 110 Shank Extensions 111 Tubing Cutters 46 Tungsten Carbide Blades 103 Work Light Lighting 43 Work Lights 48 Mine Safety Appliances Co. Hard Hat Sweatbands 315 Protective Caps 315 Safety Caps 315 Mini Flashlights 433 Mirror Lens Glasses 318 Mirrors</p>
--	---	---

<p>Inspection Mirrors 260</p> <p>Miter Saw Stands 30, 92</p> <p>Miter Saws 29, 60</p> <p>Mixers</p> <ul style="list-style-type: none"> Concrete Mixers 394 Drywall Mixers 392 <p>Mold Cleaning Brushes 191</p> <p>Mold Sealers 191</p> <p>Moldex-Metric</p> <ul style="list-style-type: none"> Ear Plugs 320 Particulate Respirators 320 <p>Molds</p> <ul style="list-style-type: none"> Cable Connecting Molds 189, 190, 192, 193 <p>Mortars</p> <ul style="list-style-type: none"> Fire Barrier Mortars 574, 579 <p>Morter Hoes 285</p> <p>Motor Saws 88</p> <p>Motors</p> <ul style="list-style-type: none"> Vibrator Motors 394 <p>Motorola</p> <ul style="list-style-type: none"> Batteries Radios 333, 334 Cables Connectivity 334 Chargers Radios 334 Headsets Radios 334 Radio Microphones 334 Two-Way Radios 333 <p>Motors</p> <ul style="list-style-type: none"> Vibrator Motors 396 <p>Mounting Brackets 457</p> <p>Moving</p> <ul style="list-style-type: none"> Sleds Moving Protection 598 <p>MultMaster Carbide Rasps 72</p> <p>MultMaster Diamond Blades 71</p> <p>MultMaster E-Cut Blades 71</p> <p>MultMaster Sanding Disc Sets 73</p> <p>MultMaster Sanding Pads 73</p> <p>MultMaster Sanding Sets 72, 73</p> <p>MultMaster Sanding Sheets 72, 73</p> <p>MultMaster Saw Blades 71, 72</p> <p>Multi-Directional Slip Base Components Telespar 593</p> <p>Multigas Detectors 312</p> <p>MultMaster Cutting Blades 71</p> <p>MultMaster Floor Kits 73</p> <p>MultMaster Sawing Kits 73</p> <p>MultMaster Scraper Blades 72</p> <p>MultMaster Sets 71</p> <p>MultMaster Wood Kits 73</p> <p>Multimeters</p> <ul style="list-style-type: none"> Manual Multimeters 182 <p>Multipurpose Bits 96</p>	<p>Multipurpose Ladders 208</p> <p>Multi-Purpose Lubricants 590</p> <p>Multiquip Inc</p> <ul style="list-style-type: none"> Concrete Mixers 394 Gas Compactors 395 Gas Rammers 364, 395 Gas Trowels 394 Trash Pumps 364 Vibrator Heads 395 Vibrator Motors 394 Vibrator Shafts 394 <p>Multi-Tools</p> <ul style="list-style-type: none"> Kits Multi-Tools 44 Leatherman Multi-Tools 266, 267, 268 <p>Mushroom Head Anchors 520</p> <p>N</p> <p>Nail Pullers 279, 280</p> <p>Nailers</p> <ul style="list-style-type: none"> Finish Nailers 536, 537 Fuel Powered Nailers 535, 536 Pneumatic Nailers 40 Positive Placement Nailers 536 <p>Nails</p> <ul style="list-style-type: none"> Box Nails 534 Brad Nails 534, 538 Common Nails 533 Finish Nails 535, 537 Framing Nails 534, 537, 538 Galvanized Nails 541 Gun Nails 541 Joist Hanger Nails 534 Positive Placement Nails 538, 541 Roofing Nails 534, 535 Siding Nails 535 <p>Narrow Crown Staplers 540</p> <p>Narrow Crown Staples 540</p> <p>National Marker Co.</p> <ul style="list-style-type: none"> Safety Sings 334 <p>Needle Scalars 351</p> <p>Newborn Brothers 583, 584</p> <ul style="list-style-type: none"> Caulk Accessories 584 Caulk Guns 583, 584 Caulk Nozzels 584 Caulk Spatulas 584 <p>Nibblers</p> <ul style="list-style-type: none"> Electric Nibblers 38, 55, 69, 70 <p>NiCad Batteries 65</p> <p>Ni-CD Batteries 66</p> <p>Nikro Industries Inc. 86, 87</p> <p>Nilfisk</p>	<p>Filter Bags Vacuum 84</p> <p>Hepa Vacuums 84</p> <p>Ni-MH Batteries 65, 66</p> <p>NiMH Batteries 65</p> <p>Nippers</p> <ul style="list-style-type: none"> Concrete Nippers 261 <p>Nipple Chucks 141</p> <p>No Mar Contacting Elements 540</p> <p>No Mar Tips 539</p> <p>Notched Trowels 394</p> <p>Nozzles</p> <ul style="list-style-type: none"> Adhesive Mixing Nozzles 498 Caulk Nozzels 584 <p>Nozzles Accesories 606</p> <p>Nozzles Accessories 606</p> <p>Nupla Corporation</p> <ul style="list-style-type: none"> Aluminum Scoops 290 Ball Pein Hammers 289 Bow Rakes 291 Brass Hammers 290 Concrete Placers 291 Cross Pein Hammers 289 Dead Blow Hammers 289 Digging Bars 292 Drain Spades 291 Fire Swatters 292 Industrial Shovels 291 Nuplabond Epoxy 292 Post Hole Diggers 291 Replacement Handles 292 Roofers Spades 291 Round Point Shovels 290 Rubber Mallets 290 Shovel Replacement Blades 292 Sledge Hammers 289, 290 Soil Probes 291 Square Point Shovels 291 Trenching Shovels 291 Western Scoops 290 <p>Nuplabond Epoxy 292</p> <p>Nut Drivers 200, 201</p> <ul style="list-style-type: none"> Sammys Nut Drivers 525 <p>Nuts</p> <ul style="list-style-type: none"> Channel Nuts 448, 449, 463, 465 Coupling Nuts 494 Hex Nuts 449, 494 Lock Nuts 494 <p>Nutsetters</p> <ul style="list-style-type: none"> Hex Drive Nutsetters 122 <p>O</p> <p>Offset Benders 170</p>
---	---	--



<p>Offset Snips 265</p> <p>Oil</p> <p>2-Stroke Engine Engine Oil 386</p> <p>Foam Filter Oil 387</p> <p>Oil Sorbents 336, 615</p> <p>Oilers</p> <p>Pump Oilers 137</p> <p>Oils</p> <p>Hydraulic Oils 184, 226</p> <p>Thread Cutting Oils 137</p> <p>Oiltight Punches 166</p> <p>Omnitec Design Inc. 87</p> <p>Orbit Sanders 90</p> <p>Oregon Wire Products</p> <p>Ceiling Wire 491</p> <p>Organizers</p> <p>Bucket Organizers 342</p> <p>OSI</p> <p>Acoustical Sealants 583</p> <p>Construction Adhesives 582, 583</p> <p>Insulating Foams 583</p> <p>Sub-Floor Adhesives 582</p> <p>Outlet Box</p> <p>Industrial-Duty Outlet Box 436</p> <p>Oztec Industries, Inc.</p> <p>Vibrator Heads 396</p> <p>Vibrator Motors 396</p> <p>Vibrator Shafts 396</p> <p>P</p> <p>Pacific Laser Systems 411, 412</p> <p>90½ Laser Level 411</p> <p>Alignment Lasers 410</p> <p>Aluminum Tripods 412</p> <p>Dectector Laser 411</p> <p>Laser Floor Stand 412</p> <p>Laser Plumb Level 410, 411, 412</p> <p>Layout Target Laser 411</p> <p>Palm Lasers 410</p> <p>Pack Batteries 25</p> <p>Padlocks</p> <p>Universal Padlocks 602</p> <p>Pads</p> <p>Fire Barrier Putty Pads 578</p> <p>Grinder Pads 36</p> <p>Hand Pads 567</p> <p>Harness Pads 303</p> <p>Knee Pads 337, 338</p> <p>Wire Reel Pads 203</p> <p>Pail Strainers 612</p> <p>Paint Markers 424</p> <p>Paint Multi Surface 424</p>	<p>Paint Rollers 614</p> <p>Paints</p> <p>Acrylic Enamel Aerosols 585</p> <p>Inverted Aerosol Markers 422, 586</p> <p>Pallet Trucks 230</p> <p>Palm Lasers 410</p> <p>Panel Clips 554</p> <p>Panel Saws 75</p> <p>Pans</p> <p>Dust Pans 613</p> <p>Paper Protection 398, 597, 599</p> <p>Parking Curbs 331</p> <p>Particulate Respirators 320</p> <p>Parts</p> <p>Plier Parts 264</p> <p>Paslode 536, 537</p> <p>Batteries 541</p> <p>Battery Cordless Tool 541</p> <p>Brad Nails 538</p> <p>Cleaners Cordless Tool 539, 589</p> <p>Construction Staplers 539</p> <p>Cordless Tool Batteries 539</p> <p>Finish Nailers 536, 537</p> <p>Finish Nails 537</p> <p>Framing Nails 537, 538</p> <p>Framing Staplers 540</p> <p>Fuel Cell 541</p> <p>Fuel Cells 539, 541</p> <p>Fuel Powered Nailers 535, 536</p> <p>Fuel Powered Staplers 539</p> <p>Lubrication Oil Cordless Tool 539</p> <p>Narrow Crown Staplers 540</p> <p>Narrow Crown Staples 540</p> <p>No Mar Contacting Elements 540</p> <p>No Mar Tips 539</p> <p>Positive Placement Nails 538</p> <p>Positive Placement Nailers 536</p> <p>Sheathing Staplers 540</p> <p>Standard Crown Staples 538, 540</p> <p>Wide Crown Staples 540</p> <p>Pavement Breakers 35</p> <p>PDA</p> <p>RFID Reader PDA 301</p> <p>Pelican Products 612</p> <p>Area Lighting 433</p> <p>Flashlight Clamps 432</p> <p>Head Lanterns 432</p> <p>Pen Light Flashlights 431</p> <p>Safety Flashlights 431, 432</p> <p>Pen Light Flashlights 431</p> <p>Pencil Sharpener 424, 603</p> <p>Pencils</p>	<p>Carpenter Pencils 424, 603</p> <p>Penetrants</p> <p>Super Penetrants 589</p> <p>Pennant Flags 331</p> <p>Pens</p> <p>Engraving Pens 351</p> <p>Perforated Benches 622</p> <p>Perforated Tables 622</p> <p>Pferd Abrasives</p> <p>Bench Grinder Bushings 561</p> <p>Bench Wheels 567</p> <p>Carbide Burs 558, 560, 561</p> <p>Cup Wheels 567, 568</p> <p>Cut-Off Wheels 568, 569, 570</p> <p>Disc Holders 566</p> <p>Dual Purpose Discs 572</p> <p>Fiber Discs 564</p> <p>File Handles 272</p> <p>Flap Discs 564, 565, 566</p> <p>Flap Discs Abrasives 566, 567</p> <p>Flap Wheels 564</p> <p>Flat Files 271</p> <p>Grinder Mandrels 571</p> <p>Grinding Wheels 570, 571, 572</p> <p>Half Round Files 271</p> <p>Hand Pads 567</p> <p>Hook & Loop Discs 567</p> <p>Knife Files 271</p> <p>MachinistsFiles 271</p> <p>Mill Files 272</p> <p>Pipeliners Wheels 572</p> <p>Plastic Bushings 561</p> <p>Ring Wheels 572</p> <p>Round Files 271</p> <p>Special Files 272</p> <p>Square Files 272</p> <p>Three Square Files 272</p> <p>Pferd Advance Brush</p> <p>Acid Brushes 614</p> <p>Broom Handle Braces 613</p> <p>Broom Handles 613</p> <p>Brush Adapters 557</p> <p>Chip Brushes 614</p> <p>Counter Dusters 613</p> <p>Cup Brushes 557</p> <p>Floor Brooms 613</p> <p>Floor Squeegees/Scrapers 614</p> <p>Paint Rollers 614</p> <p>Roller Frames 614</p> <p>Scratch Brushes 557</p> <p>Upright Brooms 614</p> <p>Wheel Brushes 558</p>
--	---	---

<p>Wire Brooms 613</p> <p>Wire Brushes 557, 614</p> <p>Pick Hammers 358</p> <p>Pick Mattocks 285</p> <p>Picks</p> <p>Prospecting Picks 279</p> <p>Railroad Picks 285</p> <p>Pillows</p> <p>Fire Barrier Pillows 579</p> <p>Firestop Pillows 574</p> <p>Pilot Bits 109</p> <p>Pilot Drills 109</p> <p>Pin Punch 260</p> <p>Pinch Bars 260, 361</p> <p>Pinlock</p> <p>Replacement Pinlock 314</p> <p>Pins</p> <p>Bull Pins 204</p> <p>Concrete and Steel Pins 544, 545</p> <p>Drift Pins 204</p> <p>Drive Pins 542, 544, 545</p> <p>Flange Pins 158</p> <p>Fuel Packs 542</p> <p>Plywood Pins 543</p> <p>Strip Pins 543</p> <p>Top Hat Pins 542, 545</p> <p>Pipe Clamps 157, 461, 462, 466</p> <p>Pipe Cutters 129, 130, 133, 134, 135, 152</p> <p>Pipe Devices</p> <p>Ultra Plastic Pipe Devices 580</p> <p>Pipe Dies 136, 137, 140, 141</p> <p>Pipe Extractors 132</p> <p>Pipe Freeze Tools 144</p> <p>Pipe Hold Downs 157</p> <p>Pipe Jack Stands 156, 157</p> <p>Pipe Jacks 156, 157</p> <p>Pipe Reamers 132</p> <p>Pipe Rollers 462</p> <p>Pipe Sleeve Positioners 489</p> <p>Pipe Stands 156</p> <p>Pipe Supports 462, 491</p> <p>Pipe Thawers 144</p> <p>Pipe Threaders 138</p> <p>Pipe Vises 128, 129, 151</p> <p>Pipe Wrenches 126, 128</p> <p>Pipeliner Wheels 572</p> <p>Pistol Grip Hammers 350</p> <p>Pistol Grip Shears 75</p> <p>Pistons</p> <p>Conduit Pistons 175</p> <p>Placers</p>	<p>Concrete Placers 291, 392</p> <p>Plan Covers 598</p> <p>Planers</p> <p>Concrete Planers 65</p> <p>Electric Planers 64</p> <p>Planks</p> <p>Scaffold Planks 208</p> <p>Telescoping Planks 206</p> <p>Plastic Anchors 521</p> <p>Plastic Buckets 612</p> <p>Plastic Bushings 561</p> <p>Plastic Fences 399</p> <p>Plastic Gloves 322, 323</p> <p>Plate Joiners 91</p> <p>Plate Levels 413</p> <p>Plates</p> <p>Anchorage Plates 300</p> <p>Bearing Plates 550</p> <p>Protection Plates 489</p> <p>Platforms</p> <p>Scaffold Platforms 210, 213, 214</p> <p>Plier Parts 264</p> <p>Pliers 262</p> <p>Cutter Pliers 195, 196</p> <p>Cutting Pliers 142, 194, 195, 261</p> <p>End-Cutting Pliers 195</p> <p>Linemen's Pliers 262</p> <p>Locking Pliers 263</p> <p>Long Nose Pliers 195, 196</p> <p>Pliers 262</p> <p>Slip Joint Pliers 196, 262</p> <p>Tongue & Groove Pliers 261</p> <p>Plugs</p> <p>Cord Plugs 435</p> <p>Industrial Plugs 436</p> <p>PVC Plugs 173</p> <p>Plumb Bobs 292, 413</p> <p>Plumb Bobs 292</p> <p>Plumbers Bits 111</p> <p>Plywood Pins 543</p> <p>Pneumatic Nailers 40</p> <p>Pneumatic Scalers 360</p> <p>Pneutek 548</p> <p>Air 548</p> <p>Steel Dock 548</p> <p>Tank 548</p> <p>Pocket Knives 269</p> <p>Pointing Saw Blades 379</p> <p>Pole Sander Handles 391</p> <p>Pole Tools</p> <p>Sammys Pole Tools 525</p> <p>Socket Kit Pole Tools 525</p>	<p>Poles</p> <p>Extension Poles 543, 547</p> <p>Fish Poles 174</p> <p>Polishers</p> <p>Electric Polishers 37, 53</p> <p>Poly Ropes 174</p> <p>Polypropylene Rope 611</p> <p>Polypropylene Sandbags 331</p> <p>Polysteel Buckets 612</p> <p>Polyurethane 606</p> <p>Polyurethane 606</p> <p>Porta Saws 376</p> <p>Portable Blowers 365, 621</p> <p>Portable Cable Boxes 434</p> <p>Portable Compressors 346</p> <p>Portable Generators 348, 349</p> <p>Portable Horizontal Lifelines 299</p> <p>Portable Labelers 604</p> <p>Portable Tristand Vise 129</p> <p>Portable Worktables 237</p> <p>Portable/Temp Anchorage Connectors</p> <p>Cable Connector Portable/Temp Anchorage Connectors 308</p> <p>Cross-Arm Strap Portable/Temp Anchorage Connectors 307</p> <p>Wire Hook Portable/Temp Anchorage Connectors 307</p> <p>Porter Cable</p> <p>Dovetail Jigs 91</p> <p>HP Routers 91</p> <p>Joining Biscuits 91</p> <p>Laminate Trimmers 90, 91</p> <p>Orbit Sanders 90</p> <p>Plate Joiners 91</p> <p>Sanders 90</p> <p>Tiger Saws 92</p> <p>Variable-Speed Sanders 90</p> <p>Positioners</p> <p>Pipe Sleeve Positioners 489</p> <p>Positioning Assembly</p> <p>Rebar Positioning Assembly 305</p> <p>Positive Placement Nails 538, 541</p> <p>Positive Placement Nailers 536</p> <p>Post Bases 551</p> <p>Post Caps 551</p> <p>Post Hole Bars 284</p> <p>Post Hole Diggers 284, 291</p> <p>Posts</p> <p>Delineator Posts 331</p> <p>Pouches</p> <p>Tool Pouches 202, 340</p>
--	--	--



<p>Powder Fasteners 544</p> <p>Powder Loads 547</p> <p>Power Bits 168</p> <p>Power Drive Threaders 137</p> <p>Power Drives 137</p> <p>Power Fishing Systems 174, 175</p> <p>Power Threader Stands 138</p> <p>Power Threaders 137, 138, 139, 140</p> <p>Power Tuggers 185</p> <p>Powers Fasteners 514, 515, 516</p> <ul style="list-style-type: none"> Bull Point Chisels 95 Bushing Chisels 95 Carbide Bits 92, 93, 94 Concrete Anchors 519 Dispensing Tools 518 Drive Pin Anchors 519 Flat Chisels 95 Ground Rod Chisels 95 Hammerdrill Bits 94 Hammer-Screw Anchors 518 Hollow Wall Anchor 520 Mushroom Head Anchors 520 Plastic Anchors 521 Scaling Chisels 95, 96 Self Tapping Screws 517 Snake Setting Tool 516 Split Drive Anchors 520 Stainless Steel Dropin 519 Toggle Bolts 520 Tools Dispensing 517 Wallboard Anchors 520, 521 Wedge Anchors 516 Wedge-Bolt Anchors 515 Wire 518 <p>Prep Machines 132</p> <p>Press Rings 145</p> <p>Press Tools</p> <ul style="list-style-type: none"> Compact Press Tools 144 Corded Press Tools 144 <p>Prick Punches 361</p> <p>Primesource 396, 531, 532, 533, 610</p> <ul style="list-style-type: none"> Anchor Bolts 534 Box Nails 534 Common Nails 533 Construction Stakes 399, 610 Exterior 533 Eye Lag 533 Eye Lag Self Drilling 533 Framing Nails 534 Joist Hanger Nails 534 Roofing Nails 534 Self-Drilling 532 	<p>Tarps 597</p> <p>Tie Wire 396</p> <p>Vinyl Coated Sinkers 534</p> <p>Wood Working 533</p> <p>Zip Slotted 531</p> <p>Probes</p> <ul style="list-style-type: none"> Soil Probes 291 <p>ProBuilt Professional Lighting, LLC 428</p> <ul style="list-style-type: none"> Floor Lights 428 Lamp Lights 429 Task Lights 428 Work Lights 428 <p>Professional Jointers 88</p> <p>Professional Squares 415</p> <p>Pro-Guards</p> <ul style="list-style-type: none"> Ladder Guards 207 <p>Proof Coil Chains 228</p> <p>Propane 368, 369</p> <ul style="list-style-type: none"> Propane 368, 369 Tank-top Propane 370, 616 <p>Propane Torch 610</p> <p>Propane Torches 159</p> <p>ProPresses</p> <ul style="list-style-type: none"> Cordless ProPresses 144, 145 <p>Prospecting Picks 279</p> <p>Protecta 299</p> <ul style="list-style-type: none"> Self - Retracting Lifelines 299 <p>Protection</p> <ul style="list-style-type: none"> Carpet Protection 597 Clean Mats Protection 598 Duct Protection 158, 599 Floor Protection 597, 598 Paper Protection 398, 599 <p>Protection Plates 489</p> <p>Protection 597, 598</p> <p>Protective Caps 315</p> <p>Protective Coveralls 330</p> <p>Protector Rebar Caps 397</p> <p>Protractors</p> <ul style="list-style-type: none"> Angle Protractors 173 Magnetic Protractors 414 <p>Pry Bars 279, 280, 361</p> <p>Pulaski Axes 285</p> <p>Pullers</p> <ul style="list-style-type: none"> Cable Pullers 176, 224 Nail Pullers 279, 280 <p>Pulling Grips 169, 178</p> <p>Pulling Rope 194, 611</p> <p>Pulling Tapes 194, 611</p> <p>Pulls</p> <ul style="list-style-type: none"> Concrete Pulls 392 	<p>Pump Jack Brace</p> <ul style="list-style-type: none"> Steel Pump Jacks 213 <p>Pump Oilers 137</p> <p>Pumps</p> <ul style="list-style-type: none"> Cylinder Pumps 227 DC Pumps 241 Hand Pumps 226, 227, 240 Hydraulic Pumps 163, 165, 166, 184 Manifold Pumps 227 Ram and Hand Pumps 163 Test Hydrostatic 151 Trash Pumps 364 Utility Pumps 364 <p>Punch</p> <ul style="list-style-type: none"> Pin Punch 260 <p>Punch & Chisel Set 259</p> <p>Punch Dies 165</p> <p>Punches</p> <ul style="list-style-type: none"> Center Punches 260 Drive Punches 163 Driver Punches 161 Hydraulic Drive Punches 162 Hydraulic Punches 164 Keyway Punches 166 Knockout Punches 162, 164, 165 Mild Steel Punches 162 Oiltight Punches 166 Prick Punches 361 Stud Punches 166 <p>Purlin Clips 489</p> <p>Push Saws 374</p> <p>Putties</p> <ul style="list-style-type: none"> Firestop Putties 575 <p>Putty Knives 269</p> <p>PVC Boots 328</p> <p>PVC Cutters 161</p> <p>PVC Heater/Benders 173</p> <p>PVC Plugs 173</p> <p>Q</p> <p>Quick Links 223</p> <p>Quick Release Ratchets 246, 249</p> <p>R</p> <p>R.A.D. Assemblies 56</p> <p>Rack Strap</p> <ul style="list-style-type: none"> Strap Mounting Brackets 244 <p>Racks</p> <ul style="list-style-type: none"> Storage Racks 183 Truck Racks 243 Vehicle Ladder Racks 243 <p>Radians</p>
---	--	---

<p>Jackets Parkas 327</p> <p>Reflective Jacket 327</p> <p>Reflective Vests 326, 327</p> <p>Radiant Heaters 366, 616</p> <p>Radio Microphones 334</p> <p>Radios 22</p> <p>Batteries Radios 334</p> <p>Chargers Radios 334</p> <p>Headsets Radios 334</p> <p>Job Site Radios 65</p> <p>Jobsite Radios 67</p> <p>Radios 22</p> <p>Two-Way Radios 333</p> <p>Radius-Type Sheaves 186</p> <p>Rags</p> <p>Cloth Wipers 615</p> <p>Colored Rags 615</p> <p>Corduroy Rags 615</p> <p>Railroad Picks 285</p> <p>Rain Gear</p> <p>Bibs Rain Gear 330</p> <p>Jackets Rain Gear 330</p> <p>Rain Suits 327, 328</p> <p>Rakes</p> <p>Asphalt Rakes 286</p> <p>Bow Rakes 285, 291</p> <p>Landscape Rakes 285</p> <p>Lawn Rakes 285</p> <p>Stone Rakes 286</p> <p>Ram and Hand Pumps 163</p> <p>Rammers</p> <p>Gas Rammers 364, 395</p> <p>Ramset/ITW</p> <p>Ceiling Clip Assemblies 546</p> <p>Concrete and Steel Pins 544, 545</p> <p>Conduit Strap Assemblies 546</p> <p>Drive Pins 542, 544, 545</p> <p>Extension Poles 543, 547</p> <p>Fastening Tools 543</p> <p>Fuel Cartridges 542, 544</p> <p>Fuel Packs 542</p> <p>Gas Fasteners 542</p> <p>Plywood Pins 543</p> <p>Powder Fasteners 544</p> <p>Powder Loads 547</p> <p>Semi Automatic Fasteners 547</p> <p>Strip Pins 543</p> <p>Threaded Rod Assemblies 546</p> <p>Threaded Studs 545, 546</p> <p>Tie Strap Holder Assemblies 547</p> <p>Top Hat Pins 542, 545</p> <p>Ratchet</p>	<p>Replacement Ratchet 314</p> <p>Ratchet Adapters 250, 252, 254, 255</p> <p>Ratchet and Handle Threaders 135</p> <p>Ratchet Extensions 254</p> <p>Ratchet Load Binders 228</p> <p>Ratchet Repair Kits 253</p> <p>Ratchet Threaders 135</p> <p>Ratchet Tie Downs 217</p> <p>Ratchet Wrenches 163, 165</p> <p>Ratcheting Wrenches 201</p> <p>Ratchets 351</p> <p>Air Ratchets 350</p> <p>Drive Ratchets 251, 254</p> <p>Flex Head Ratchets 249, 252</p> <p>Long Handle Ratchets 252</p> <p>Quick Release Ratchets 246, 249</p> <p>Ratchet Repair Kits 253</p> <p>Ratchets 351</p> <p>Round Head Ratchets 252</p> <p>Teardrop Ratchets 251</p> <p>Raven Industries</p> <p>Building Enclosure Films 596</p> <p>Vapor Retarders 397, 596, 597</p> <p>Rayovac</p> <p>Alkaline Batteries 431</p> <p>Industrial Flashlights 430, 431</p> <p>Industrial Lanterns 430</p> <p>Krypton Bulbs 431</p> <p>LED Flashlight Industrial Clamp Flashlight 431</p> <p>Razor Blade Scrapers 270</p> <p>Razor Blades 270</p> <p>Razors</p> <p>Razor Blades 270</p> <p>Reamers</p> <p>Alignment Reamers 274</p> <p>Conduit Reamers 203</p> <p>Inner/Outer Reamers 135</p> <p>Pipe Reamers 132</p> <p>Rebar Caps</p> <p>Protector Rebar Caps 397</p> <p>Rebar Cutter/Benders 282</p> <p>Rebar Cutters 96</p> <p>Rebar Hickeys 204</p> <p>Rebar Positioning Assembly 305</p> <p>Rebar Protector Caps 396</p> <p>Receding Threaders 136</p> <p>Receptacle Covers 463</p> <p>Reciprocating Saw Blades 102</p> <p>Reciprocating Saws 19, 27, 45, 48, 49, 57, 60, 67, 351</p> <p>Red Steer 618</p>	<p>Redhead/ITW</p> <p>Acrylic Adhesives 506</p> <p>Blow-Out Bulbs 514</p> <p>Drop-In Anchors 511, 512</p> <p>Drop-In Setting Tools 512</p> <p>Epoxy Adhesives 506, 507</p> <p>Masonry Anchors 514</p> <p>Sleeve Anchors 513</p> <p>Wedge Anchors 509, 510, 511</p> <p>Reduced Shank Drills 113</p> <p>Reed Mfg 150, 151</p> <p>Blades Cutters 154</p> <p>Deburring Tools 151</p> <p>Hinged Cutters 151</p> <p>Manhole Hooks Municipal Castings 152</p> <p>Pipe Cutters 152</p> <p>Pipe Vises 151</p> <p>Squeeze-Off PE Pipes 152</p> <p>Test Hydrostatic 151, 152</p> <p>Tubing Cutter Wheels 150</p> <p>Valve Keys 153</p> <p>Valve Wheel Wrenches 154</p> <p>Reel Spindles 184</p> <p>Reel Stands 184</p> <p>Reels</p> <p>Chalk Reels 418</p> <p>Industrial-Duty Reels 437</p> <p>Line Reels 423</p> <p>Tie-Wire Reels 203</p> <p>Refill Chalks 423</p> <p>Reflective Jacket 327</p> <p>Reflective Vests 326, 327</p> <p>Reinforced Paper Protection 598</p> <p>Reinforced Wipers 590</p> <p>Relton Corp.</p> <p>Cutting Fluids 96</p> <p>Metal Cutting Fluids 96, 97</p> <p>Multipurpose Bits 96</p> <p>Rebar Cutters 96</p> <p>Stick Waxes 97</p> <p>Stop Bits 96</p> <p>Repair Kit</p> <p>Fiberglass Repair Kit 173</p> <p>Replacement Blades</p> <p>Shovel Replacement Blades 292</p> <p>Replacement Blades Shears 76, 77</p> <p>Replacement Handles 292</p> <p>Replacement Pinlock 314</p> <p>Replacement Ratchet 314</p> <p>Replacement Taps 203</p>
--	---	---



<p>Replacement Wheels Pipe Cutters 131</p> <p>Rescue Retrieval Kit Rescue 310</p> <p>Rescue/Retrieval Systems 301, 308</p> <p>Respirator Accessories 321</p> <p>Respirators Full Face Respirators 320 Half Mask Respirators 320 Particulate Respirators 320</p> <p>Retarders Boot Kit 397</p> <p>Retarders Seam Tape 397, 597</p> <p>Retarders 397, 596</p> <p>Retractable Blade Knives 269</p> <p>Retractable Cable 309</p> <p>Retractable Lifeline 309, 310</p> <p>Retractables Lifelines 309</p> <p>Retrieval Kit Rescue 310</p> <p>Retro-Fit Tag 301</p> <p>Reusable Earplugs 318, 319</p> <p>R-Factor 574</p> <p>RFID Reader PDA 301</p> <p>Rhino Anti-Fatigue Mat 336, 337</p> <p>Rhino Labels 604</p> <p>Ridgid/Ridge Tool Co. Basin Wrenches 128 Bench Chain Vise 129 Bolt Dies 141 Box End Wrenches 126 Camera Extensions 145 Chain Vises 129 Chain Wrenches 127 Cleaning Brushes 135 Closet Augers 146 Combination Bench & Pipe Vise 142 Compact Press Tools 144 Corded Press Tools 144 Cordless ProPresses 144, 145 Cutter Blades 134, 135 Cutter Wheels 131, 133 Cutting Pliers 142 Deburring Tools 135 Die Heads 140 Drain Cleaner Cables 147, 148, 149 Drain Cleaners 146, 147, 148, 149 Drain Line Cleaners 149 Electric Hole Cutters 142 Flaring Tools 143 Folding Rules 142 Geared Threader Shafts 139 Geared Threaders 136</p>	<p>Hand Pipe 130 Hex Wrench 126 Inner/Outer Reamers 135 Inspection Cameras 145, 146 Internal Wrenches 127 Lever Benders 143 Nipple Chucks 141 Pipe Cutters 129, 130, 133, 134, 135 Pipe Dies 136, 137, 140, 141 Pipe Extractors 132 Pipe Freeze Tools 144 Pipe Reamers 132 Pipe Thawers 144 Pipe Threaders 138 Pipe Vises 128, 129 Pipe Wrenches 126, 128 Portable Tristand Vise 129 Power Drive Threaders 137 Power Drives 137 Power Threader Stands 138 Power Threaders 137, 138, 139, 140 Prep Machines 132 Press Rings 145 Pump Oilers 137 Ratchet and Handle Threaders 135 Ratchet Threaders 135 Receding Threaders 136 Replacement Wheels Pipe Cutters 131 Roll Groovers 141 Roll Grooving Machines 142 Screw Extractors 142 Soft Material Flaring Tools 143 Soldering Guns 143 Spring Loaded Jaw Basin Wrench 128 Spud Wrenches 127 Strap Wrenches 127 Thread Cutting Oils 137 Threader Die Heads 138, 139 Threading Machine Die Heads 136 Threading Machines 138, 139 Torque Wrenches 128 Tube Benders 143 Tubing Benders 143 Tubing Cutters 133, 134 Universal Die Heads 138 Utility Locators 146 Wet/Dry Vacuums 86</p> <p>Rigger Kits 229</p> <p>Right Angle Attachments 55</p> <p>Right Angle Drills 51</p>	<p>Right Angle Grinders 19, 35</p> <p>Rigs Core Drills Rigs 372 Drill Rigs 372 Vacuum Pumps Rigs 372</p> <p>Ring Wheels 572</p> <p>Rings Press Rings 145 Ret Rings 255, 256</p> <p>Rip Hammers 277, 278</p> <p>Ripping Bars 279</p> <p>Rivet Busters CPS Rivet Busters 354</p> <p>Rivet Shank 360</p> <p>Riveters Hand Riveters 282</p> <p>Rock Drills 358, 359</p> <p>Rod Backer Rod 398</p> <p>Rod and Wire Hangers 491</p> <p>Rod Cutters 184</p> <p>Rod Hangers 489</p> <p>Rods Extension Rods 379 Threaded Rods 466</p> <p>Roll Groovers 141</p> <p>Roll Grooving Machines 142</p> <p>Roll Visqueen 596</p> <p>Roller Frames 614</p> <p>Rollers Heavy Moving Rollers 229 Paint Rollers 614 Pipe Rollers 462 Support Rollers 172</p> <p>Roof Brackets Roof 213</p> <p>Roof Access Hatch 605</p> <p>Roof Anchors 299, 300, 307, 311</p> <p>Roof Anchors Permanent 308</p> <p>Roof Clips 553</p> <p>Roofers Shovels 286</p> <p>Roofers Spades 291</p> <p>Roofing Nails 534, 535</p> <p>Roofmaster Products CO. Magnetic Seepwers 614</p> <p>Rope Manila Rope 194, 611 Mason Twine 194, 611 Polypropylene Rope 611 Pulling Rope 194, 611</p> <p>Rope Clevis 177</p> <p>Rope Grabs 299, 307</p>
--	--	---

<p>Rope Lifeline 310</p> <p>Rope Lifeline System</p> <p>Rope Lifeline 310</p> <p>Rope Lifelines 307</p> <p>Rope Stands 177</p> <p>Ropes</p> <p>Poly Ropes 174</p> <p>Rotary Hammer Bits 97</p> <p>Rotary Hammers 19, 33, 34, 47, 80</p> <p>Electric Rotary Hammers 62, 69</p> <p>Rothenberger</p> <p>Compact Threading Machines 154</p> <p>Cordless Cameras 155</p> <p>Crimping Tools Joiner 155</p> <p>Rotozip 74</p> <p>Collets and Nuts 74</p> <p>Grout Removal 74</p> <p>Routers 74</p> <p>Spiral Saw 73, 74</p> <p>Round Files 271</p> <p>Round Head Ratchets 252</p> <p>Round Hole Channels 444</p> <p>Round Point Shovels 286, 287, 290</p> <p>Round Shank Screwdrivers 200</p> <p>Rousseau</p> <p>Miter Saw Stands 92</p> <p>Stands 92</p> <p>System Batter Boards 92</p> <p>Router</p> <p>Routers 74</p> <p>Routers 74</p> <p>Electric Routers 39, 40, 70</p> <p>HP Routers 91</p> <p>Rub Bricks 388</p> <p>Rubber Floats 390</p> <p>Rubber Gloves 323</p> <p>Rubber Mallets 278</p> <p>Rubber Mallets 290</p> <p>Rubber Straps 610</p> <p>Rubbermaid Commercial Products</p> <p>Angle Brooms 613</p> <p>Carry Caddies 237</p> <p>Dust Pans 613</p> <p>Industrial Tilt Truck 231</p> <p>Spray Bottle 613</p> <p>Standard Duty Dollies 230</p> <p>Standard Duty Tilt Truck 231</p> <p>Standard Duty Trollies 231</p> <p>Tool Boxes 237</p> <p>Trash Cans 612</p> <p>Utility Carts 231</p> <p>Water Coolers Drinks 332, 333, 620</p>	<p>Rules</p> <p>Folding Rules 142, 419</p> <p>Tape Rules 418</p> <p>Wood Rules 419</p> <p>Rung Locks</p> <p>Ladder Locks 207</p> <p>S</p> <p>Safety Cans 244, 335</p> <p>Safety Caps 315</p> <p>Safety Earmuffs 319, 320</p> <p>Safety Flashlights 431, 432</p> <p>Safety Glasses 315, 316, 317</p> <p>Safety Goggles 316, 317</p> <p>Safety Harnesses 296</p> <p>Safety Headgears 316</p> <p>Safety Kit 335, 615</p> <p>Safety Lanyards 297, 305</p> <p>Safety Lifelines 299</p> <p>Safety Shirts 326</p> <p>Safety Sings 334</p> <p>Safety Vests 326</p> <p>Safway Services 212</p> <p>Sammys</p> <p>Concrete Sammys 525</p> <p>Metal Sammys 524</p> <p>Steel Sammys 522, 523</p> <p>Toggle Sammys 526</p> <p>Wood Sammys 521, 522</p> <p>X-Press It Sammys 525</p> <p>Sammys Nut Drivers 525</p> <p>Sammys Pole Tools 525</p> <p>San Angelo Bars 284</p> <p>Sandbags</p> <p>Polypropylene Sandbags 331</p> <p>Sanders 90</p> <p>Belt Sanders 39, 64</p> <p>Electric Sanders 38, 39, 63, 64</p> <p>Orbit Sanders 90</p> <p>Sanders 90</p> <p>Variable-Speed Sanders 90</p> <p>Wheel Sanders 64</p> <p>Saw</p> <p>Chain Saw 363</p> <p>Spiral Saw 73, 74</p> <p>Saw Blades 66, 76, 376</p> <p>Saw Circular 77</p> <p>Saw Kits 24, 42</p> <p>Saws</p> <p>Aluminum Hacksaws 161</p> <p>Band Saws 37, 48, 54, 57, 64, 79</p> <p>Box Saws 293</p> <p>Chain Saws 363</p> <p>Chop Saws 38, 64</p> <p>Circular Saws 27</p> <p>Circular Saws 28, 43, 47, 49, 55, 61, 67, 68</p> <p>Concrete Cutting Saws 375</p> <p>Concrete Push Saws 374</p> <p>Concrete Saws 80, 373, 374, 378</p> <p>Contractors Saws 87</p> <p>Cut-Off Saws 55</p> <p>Cutoff Saws 374, 375</p> <p>Finish Saws 293</p> <p>Flat Saws 378</p> <p>Gas Powered Saws 62, 373</p> <p>Hack Saws 79</p> <p>Hole Saws 106, 107, 109, 170, 380</p> <p>Hybrid Saws 88</p> <p>Hypoid Saws 61</p> <p>Jab Saws 292</p> <p>Jig Saws 19, 28, 58, 68</p> <p>Keyhole Saws 169</p> <p>Masonry Saws 373</p> <p>Metal Cut Saws 57</p> <p>Miter Saw Stands 30</p> <p>Miter Saws 29, 60</p> <p>Motor Saws 88</p> <p>Panel Saws 75</p> <p>Porta Saws 376</p> <p>Push Saws 374</p> <p>Reciprocating Saws 19, 27, 45, 48, 49, 57, 60, 67, 351</p> <p>Scroll Saws 28</p> <p>Table Saw Stands 30</p> <p>Table Saws 29, 60</p> <p>Tiger Saws 92</p> <p>Track Saws 30</p> <p>Trim Saws 67</p> <p>Wallboard Saws 293</p> <p>Worm Drive Saws 67</p> <p>Sawzall Blades 102, 103, 104</p> <p>Sawzalls</p> <p>Reciprocating Saws 49</p> <p>Scabblers 354</p> <p>Scabblers 354</p> <p>Scaffold Planks 208</p> <p>Scaffold Platforms 210, 213, 214</p> <p>Scalers</p> <p>Ergonomic Scalers 358</p> <p>Needle Scalers 351</p> <p>Pneumatic Scalers 360</p> <p>Scaling Chisels 95, 96</p> <p>Scissor Head Shears 76</p>
---	--



<p>Scissor Lifts 215, 216</p> <p>Scoops Aluminum Scoops 290 Grain Scoops 288 Western Scoops 290</p> <p>Scraper Bars 279</p> <p>Scrapers Floor Scrapers 392 Material Scrapers 286 Razor Blade Scrapers 270 Sidewalk/Ice Scrapers 286, 619 Wall Scrapers 269</p> <p>Scratch Awls 203</p> <p>Scratch Brushes 557</p> <p>Screeds Magnesium Screeds 392</p> <p>Screens Wire Screens 499</p> <p>Screw Anchors 501</p> <p>Screw Extractors 142, 260, 274</p> <p>Screw Machine Length Drills 112</p> <p>Screwdriver Sets 264 Set Screwdrivers 199, 200</p> <p>Screwdrivers 11-in-1 Screwdrivers 200 6-Way Screwdrivers 264 Cordless Screwdrivers 18 Cushion Grip Screwdrivers 199, 200 Cushion-Grip Screwdrivers 199, 200 Electric Screwdrivers 32, 51 Folding Screwdrivers 276 Interchangeable Bit Screwdrivers 117 Round Shank Screwdrivers 200</p> <p>Screws Deck Screws 554 Self Tapping Screws 517 Sub Floor Screws 555</p> <p>Scroll Saw Stands 30</p> <p>Scroll Saws 28</p> <p>SDS DUST EXTRACTION SYSTEMS 26, 27 SDS DUST EXTRACTION SYSTEMS 26, 27</p> <p>Sealants Acoustical Sealants 583 Concrete Cleaner 408 Concrete Sealer Compound 401, 404, 405, 406 Elastomeric Sealants 575 Firestop Sealants 575 Intumescent Sealants 575</p>	<p>Silicone Sealants 582</p> <p>Sealer Compound Concrete Sealer Compound 406</p> <p>Sealers Mold Sealers 191</p> <p>Seats Tool Bucket Seats 342</p> <p>Security Lockouts 603</p> <p>Seepwers Magnetic Seepwers 614</p> <p>Segmented Blades 380</p> <p>Self - Retracting Lifelines 298, 299</p> <p>Self Drilling Eye Lag Self Drilling 533</p> <p>Self Retracting Lifelines 298, 306</p> <p>Self Tapping Screws 517</p> <p>Self-Drilling 532 Self-Drilling 532</p> <p>Self-feed Bits 110</p> <p>Self-Retracting Arrestor 306</p> <p>Self-Retracting Limiter 306</p> <p>Self-Retracting Limiters 306</p> <p>Semi Automatic Fasteners 547</p> <p>Sensors Stud Sensors 422</p> <p>Set Dado Set 89 Punch & Chisel Set 259</p> <p>Set Screwdrivers 199, 200</p> <p>Sets Bricklayer Sets 280 Caster Sets 237 MulitMaster Sanding Disc Sets 73 MulitMaster Sanding Sets 72, 73 MultiMaster Cutting Blades 71 MultiMaster Floor Kits 73 MultiMaster Sawing Kits 73 MultiMaster Scraper Blades 72 MultiMaster Sets 71 MultiMaster Wood Kits 73 Screwdriver Sets 264</p> <p>Setting Tool Anchor Setting Tool 504</p> <p>Setting Tools Drop-In Setting Tools 512</p> <p>Shackles Anchor Shackles 222</p> <p>Shaft Adapters 383</p> <p>Shafts Extension Shafts 383 Geared Threader Shafts 139 Vibrator Shafts 394, 396</p>	<p>Shank Rivet Shank 360</p> <p>Shank Chucks 70</p> <p>Shank Extensions 111</p> <p>Sharpener Pencil Sharpener 424, 603</p> <p>Sharpie Markers 424, 425, 604</p> <p>Shear Double-Cut Shears 75 Fiber Cement Shears 122 Heavy Duty Shears 122</p> <p>Shears Cordless Shears 20, 27 Electric Nibbler Attachment 76 Electric Shears 38, 55, 65, 69, 76 Head Shears 76 Metal Shears 122 Replacement Blades Shears 76, 77 Scissor Head Shears 76 Variable Speed Shears 76</p> <p>Sheathing Staplers 540</p> <p>Sheaves Adapter Sheaves 176 Feeding Sheaves 176, 177 Hook-Type Sheaves 176, 185, 186 Radius-Type Sheaves 186 Tray-Type Sheaves 186</p> <p>Sheet Metal Clamps 263</p> <p>Sheets Fire Barrier Sheets 579 MulitMaster Carbide Rasps 72 MulitMaster Sanding Pads 73 MulitMaster Sanding Sheets 72, 73</p> <p>Shirts Safety Shirts 326</p> <p>Shock Absorbing Lanyards 296, 297, 304, 305, 309</p> <p>Shoe Bending Shoe 172</p> <p>Shoe Covers 598</p> <p>Shoe Groups Bending Shoe Groups 171, 172</p> <p>Shoes Ladder Shoes 207</p> <p>Shop Lights 429</p> <p>Shop Vac Corp. Vacuum Filter Bags 86 Vacuum Filters 85, 86 Vacuum Hose Converters 86 Vacuum Hose Couplings 86 Vacuum Hoses 86 Wet/Dry Vacuums 85</p>
--	--	--

<p>Short Combination Wrench 257</p> <p>Short Pattern Wrenches 259</p> <p>Shovel Replacement Blades 292</p> <p>Shovels</p> <ul style="list-style-type: none"> Industrial Shovels 291 Irrigation Shovels 286 Roofers Shovels 286 Round Point Shovels 286, 287 Square Point Shovels 287 Trench Shovels 287 Trenching Shovels 288, 291 <p>Side Cutters 195, 196, 197</p> <p>Sidewalk/Ice Scrapers 286, 619</p> <p>Siding Nails 535</p> <p>Signs</p> <ul style="list-style-type: none"> Traffic Paddles 331 <p>Silicone Caulks 578</p> <p>Silicone Sealants 582</p> <p>Simpson Strong-Tie 495, 496, 497, 498, 499, 500, 501, 502, 504, 505, 550, 551, 552, 553, 554, 555</p> <ul style="list-style-type: none"> Adhesive Mixing Nozzles 498 Anchor Setting Tool 504 Bearing Plates 550 Column Caps 552 Deck Screws 554 Drop-In Anchors 503, 504 Epoxy Cartridges 496 Joist 552 Panel Clips 554 Post Bases 551 Post Caps 551 Roof Clips 553 Screw Anchors 501 Sleeve Anchors 502, 503 Square Drive Bits 555 Strap Tie Holdowns 550 Sub Floor Screws 555 Tension Holdowns 550 Truss Hangers 552 Twist Straps 553 Wall Ties 505 Wire Screens 499 <p>Single-Acting Cylinders 226</p> <p>Sinkers</p> <ul style="list-style-type: none"> Vinyl Coated Sinkers 534 <p>Sledge Hammers 288, 289, 290</p> <p>Sleds Moving Protection 598</p> <p>Sleeve Anchors 502, 503, 513</p> <p>Sleeve Firestop Systems 573, 574</p> <p>Sleeves</p>	<p>Cable Sleeves 301</p> <p>Sliding T Handles 254</p> <p>Slings</p> <ul style="list-style-type: none"> Endless Slings 218 Safety Slings 334 Web Slings 217 <p>Slip Base Bottom/Anchor Telespar 593</p> <p>Slip Joint Pliers 196, 262</p> <p>Slotted</p> <ul style="list-style-type: none"> Zip Slotted 531 <p>Slotted Channels 465</p> <p>Smoke and Sound</p> <ul style="list-style-type: none"> Smoke Sealants 574 <p>Smoke Lens Glasses 318</p> <p>Smoke Sealants 574</p> <p>Snake Setting Tool 516</p> <p>Snap Off Knives 269</p> <p>Snappi Hooker</p> <ul style="list-style-type: none"> Rubber Straps 610 <p>Snips</p> <ul style="list-style-type: none"> Aluminum Snips 265 Aviation Snips 265 Compound Action Snips 265 Electrician Snips 203 Offset Snips 265 Tinner Snips 266 <p>Soap</p> <ul style="list-style-type: none"> Hand Soaps 590 <p>Soapstone Markers 424</p> <p>Socket Adapters 122</p> <p>Socket Channel 256</p> <p>Socket Extensions 118</p> <p>Socket Kit Pole Tools 525</p> <p>Sockets</p> <ul style="list-style-type: none"> Deep Impact Sockets 246 Deep Sockets 249, 251 Fractional Sockets 245, 246, 247, 248, 249, 250, 251, 254 Fractional/Metric Sockets 245 Hex Sockets 246, 248, 249, 251 Impact Sockets 247, 248, 253, 255 Industrial-Duty Sockets 436 Lobular Opening Sockets 255 Metric Sockets 246, 247 Spark Plug Sockets 249, 250 <p>Soft Material Flaring Tools 143</p> <p>Soil Probes 291</p> <p>Soldering Guns 143</p> <p>Solid Channels 444, 445, 446, 447, 464, 465</p>	<p>Sonneborn 400, 402, 403, 404, 405, 406, 407, 408, 409, 581</p> <ul style="list-style-type: none"> Concrete Caulk 406, 408, 581 Concrete Cleaner 408 Concrete Dampproofing 404 Concrete Foundation 404 Concrete Hardener 400 Concrete Sealer Compound 401, 404, 405, 406 <p>Sonotube</p> <ul style="list-style-type: none"> Concrete Forms 398 <p>Sorbents</p> <ul style="list-style-type: none"> Oil Sorbents 336, 615 <p>Spade Bits 116</p> <p>Spades</p> <ul style="list-style-type: none"> Drain Spades 291 Roofers Spades 291 <p>Spark Lighters 159</p> <p>Spark Plug Sockets 249, 250</p> <p>Spatulas</p> <ul style="list-style-type: none"> Caulk Spatulas 584 <p>Special Files 272</p> <p>Specified Technologies 575, 576, 577, 578</p> <ul style="list-style-type: none"> Cable Firestop Systems 576 Collar Firestop 573 Elastomeric Sealants 575 Fire Barrier Mortars 574 Fire Barrier Sheets 573 Fire Barrier Sprays 573 Firestop Grommets 577 Firestop Pillows 574 Firestop Putties 575 Firestop Sealants 575 Intumescent Sealants 575 Sleeve Firestop Systems 573, 574 Smoke Sealants 574 Strips Wrap 574 <p>Speed Bumps 331</p> <p>Speed Squares 416</p> <p>Speeder Handles 250, 252</p> <p>Spindle</p> <ul style="list-style-type: none"> Reel Spindles 184 <p>Spiral Saw 73, 74</p> <ul style="list-style-type: none"> Spiral Saw 73 <p>Splicer 607</p> <ul style="list-style-type: none"> Splicer 607 <p>Splicers</p> <ul style="list-style-type: none"> Cable Splicers 203 <p>Splices</p> <ul style="list-style-type: none"> Horizontal Splices 191 <p>Split Drive Anchors 520</p>
---	---	---



<p>Split-Head Hammers 279</p> <p>Spray Adhesives 588</p> <p>Spray Applicators 591</p> <p>Spray Bottle 613</p> <p>Spray Lubricants 591</p> <p>Sprayers</p> <ul style="list-style-type: none"> Backpack Sprayers 399 Concrete Sprayers 399 Degreasing/Cleaning Sprayers 399 <p>Sprayon 589</p> <ul style="list-style-type: none"> Corrosion Inhibitors 585 Cutting Lubricants 587 Electronic Cleaners 587 Insect Insecticides 587 Maintenance Cleaners 587 <p>Sprays</p> <ul style="list-style-type: none"> Fire Barrier Sprays 573, 579 <p>Spreaders</p> <ul style="list-style-type: none"> Tube Spreaders 227 <p>Spring Claws 260</p> <p>Spring Loaded Jaw Basin Wrench 128</p> <p>Spud Wrenches 127</p> <p>Square Drive Bits 555</p> <p>Square Files 272</p> <p>Square Ornamental Trowels 393</p> <p>Square Point Shovels 287, 291</p> <p>Squares</p> <ul style="list-style-type: none"> Carpenter Squares 416 Combination Squares 414, 415, 416 Framing Squares 415 Professional Squares 415 Speed Squares 416 Try Squares 415 <p>Squeegees & Scrapers</p> <ul style="list-style-type: none"> Floor Squeegees/Scrapers 614 <p>Squeeze-Off</p> <ul style="list-style-type: none"> Squeeze-Off PE Pipes 152 <p>Squeeze-Off PE Pipes 152</p> <p>Stabila</p> <ul style="list-style-type: none"> Electronic Levels 413 Extendable Levels 413 Lasers Measures 422 Magnetic Levels 413 Plate Levels 413 Torpedo Levels 413 <p>Stabilizer Ladder 207, 311</p> <p>Stabilizers</p> <ul style="list-style-type: none"> Ladder Stabilizers 206 <p>Stablizer</p> <ul style="list-style-type: none"> Ladder Stabilizer 207 <p>Stainless Steel Dropin 519</p>	<p>Stakes</p> <ul style="list-style-type: none"> Construction Stakes 399, 610 <p>Stand</p> <ul style="list-style-type: none"> Laser Floor Stand 412 <p>Standard Crown Staples 538, 540</p> <p>Standard Duty Dollies 230</p> <p>Standard Duty Tilt Truck 231</p> <p>Standard Duty Trollies 231</p> <p>Stands 92</p> <ul style="list-style-type: none"> Miter Saw Stands 92 Pipe Jack Stands 156, 157 Pipe Stands 156 Power Threader Stands 138 Reel Stands 184 Rope Stands 177 Scroll Saw Stands 30 Stands 92 <p>Stanley Industrial Tools 270</p> <ul style="list-style-type: none"> 6-Way Screwdrivers 264 Ball Pein Hammers 289 Box Saws 293 Cable Staples 282 Carpenter Squares 416 Chalk Reels 418 Combination Squares 416 Crown Staples 281 Dead Blow Hammers 289 Finish Saws 293 Hammer Tackers 280 Jab Saws 292 Knife Blades 270 Measuring Tapes 418 Plumb Bobs 292 Pocket Knives 269 Pry Bars 280 Putty Knives 269 Razor Blade Scrapers 270 Razor Blades 270 Retractable Blade Knives 269 Screwdriver Sets 264 Snap Off Knives 269 Speed Squares 416 Staple Guns 281 Stud Sensors 422 Tape Measures 417, 418 Tape Rules 418 Torpedo Levels 416 Utility Bars 280 Utility Knives 269 Wall Scrapers 269 Wallboard Saws 293 Wood Chisels 292 	<p>Staple Gun</p> <ul style="list-style-type: none"> Staples, Nails Staple Guns, Nail Guns 281 <p>Staple Guns 281</p> <p>Staplers</p> <ul style="list-style-type: none"> Construction Staplers 539 Framing Staplers 540 Fuel Powered Staplers 539 Narrow Crown Staplers 540 Sheathing Staplers 540 <p>Staples</p> <ul style="list-style-type: none"> Cable Staples 282 Crown Staples 281 Fine Wire Staples 535 Medium Crown Staples 535 Narrow Crown Staples 540 Standard Crown Staples 538, 540 Wide Crown Staples 540 <p>Staples, Nails Staple Guns, Nail Guns 281</p> <p>Starrett 420, 421</p> <p>Station Eyewash 334</p> <p>Steel Bits 101, 118</p> <p>Steel Dock 548</p> <ul style="list-style-type: none"> Steel Dock 548 <p>Steel Hammers 277</p> <p>Steel Pump Jacks 212, 213</p> <p>Steel Sammys 522, 523</p> <p>Steel Saw Blades 66</p> <p>Step Bits 118, 168</p> <p>Step Ladders 205</p> <p>Step Tools 393</p> <p>Stick Waxes 97</p> <p>Stilts Drywall 225</p> <p>Stinson</p> <ul style="list-style-type: none"> Ladders Jacks 207 Leveler Ladders 208 Multipurpose Ladders 208 Scaffold Planks 208 Wall Standoff Ladders 208 <p>Stix</p> <ul style="list-style-type: none"> Fish Stix 174 <p>Stock Wedges 361</p> <p>Stone Rakes 286</p> <p>Stop Bits 96</p> <p>Storage Cabinets 182, 234, 235, 237, 244</p> <p>Storage Racks 183</p> <p>Strainers</p> <ul style="list-style-type: none"> Pail Strainers 612 <p>Strap</p> <ul style="list-style-type: none"> Trauma Safety Strap 301
---	---	---

<p>Strap Hanger Clips 490</p> <p>Strap Mounting Brackets 244</p> <p>Strap Tie Holdowns 550</p> <p>Strap Wrenches 127</p> <p>Straps</p> <ul style="list-style-type: none"> Beam Clamp Straps 457, 461 Rubber Straps 610 Tie Down Straps 344 Tow Straps 218 Twist Straps 553 <p>Stringliner Company</p> <ul style="list-style-type: none"> Line Reels 423 <p>Strip Pins 543</p> <p>Strippers</p> <ul style="list-style-type: none"> Cable Strippers 181, 198 Wire Strippers 161, 197, 198 <p>Strips</p> <ul style="list-style-type: none"> Closure Strips 447 <p>Strips Wrap 574</p> <p>Strut Clamps 488</p> <p>Stud Punches 166</p> <p>Stud Sensors 422</p> <p>Studs</p> <ul style="list-style-type: none"> Draw Studs 163, 165 Threaded Studs 545, 546 <p>Sub Floor Screws 555</p> <p>Sub-Floor Adhesives 582</p> <p>Suits</p> <ul style="list-style-type: none"> Rain Suits 327, 328 <p>Sumner 155, 156, 157, 158</p> <ul style="list-style-type: none"> Contractor Lifts 156 Cricket Carts 158 Flange Pins 158 Grasshopper Carts 158 Material Lifts 155, 217 Pipe Clamps 157 Pipe Hold Downs 157 Pipe Jack Stands 156, 157 Pipe Jacks 156, 157 Pipe Stands 156 Welding Clamps 157 <p>Super Penetrants 589</p> <p>Support Rollers 172</p> <p>Supports</p> <ul style="list-style-type: none"> Back Supports 343 Cable/Conduit Supports 490 Conduit Supports 489 Pipe Supports 462, 491 <p>Surface Shields 601, 602</p> <ul style="list-style-type: none"> Adhesive Zipper 598 Carpet Protection 597 Clean Mats Protection 598 	<p>Duct Protection 158, 599</p> <p>Floor Protection 597, 598</p> <p>Masking Tapes 599</p> <p>Paper Protection 398, 597, 599</p> <p>Plan Covers 598</p> <p>Reinforced Paper Protection 598</p> <p>Shoe Covers 598</p> <p>Sleds Moving Protection 598</p> <p>Suspenders</p> <ul style="list-style-type: none"> Leather Suspenders 344 Work Suspenders 343 <p>Swaging Tools 228</p> <p>Swatters</p> <ul style="list-style-type: none"> Fire Swatters 292 <p>Sweatbands</p> <ul style="list-style-type: none"> Drybrow Sweatbands 314 Hard Hat Sweatbands 314, 315 <p>Switches</p> <ul style="list-style-type: none"> Foot Switches 176 <p>Swivel Hangers 463</p> <p>System Batter Boards 92</p> <p>Systems</p> <ul style="list-style-type: none"> Rescue/Retrieval Systems 301, 308 <p>T</p> <p>T- Handles 250, 252</p> <p>Table Saw Stands 30</p> <p>Table Saws 29, 60</p> <p>Tables</p> <ul style="list-style-type: none"> Bending Tables 172 Perforated Tables 622 <p>Tackers</p> <ul style="list-style-type: none"> Hammer Tackers 280, 281 Manual Tackers 281 Wire Tackers 281 <p>Tag</p> <ul style="list-style-type: none"> Retro-Fit Tag 301 <p>Tampers</p> <ul style="list-style-type: none"> Concrete Tampers 392 <p>Tank 548</p> <ul style="list-style-type: none"> Tank 548 <p>Tanks</p> <ul style="list-style-type: none"> Transfer Tanks 239 <p>Tank-top Propane 370, 616</p> <p>Tap Wrenches 274</p> <p>Tape Measures 177, 416, 417, 418, 419</p> <p>Tape Rule Holders 343</p> <p>Tape Rules 418</p> <p>Tapes</p> <ul style="list-style-type: none"> Barricade Tapes 335 Conduit Measuring Tapes 194, 611 	<p>Fish Tapes 185</p> <p>Flagging Tapes 335</p> <p>Masking Tapes 599</p> <p>Measuring Tapes 418</p> <p>Pulling Tapes 194, 611</p> <p>Taping Knives 391</p> <p>Tappers</p> <ul style="list-style-type: none"> Electric Tappers 68 <p>Tapping Tools</p> <ul style="list-style-type: none"> Thread Tapping Tools 203 <p>Taps</p> <ul style="list-style-type: none"> Carbon Steel Taps 273, 274 Combination Taps 274 Hand Pipe 130 High Speed Steel Taps 273 Replacement Taps 203 <p>Target 409</p> <p>Tarps 597</p> <ul style="list-style-type: none"> Tarps 597 <p>Task Lights 428</p> <p>Teardrop Ratchets 251</p> <p>Tee Cables 191</p> <p>Tee Manifolds 609</p> <p>Telescoping Planks 206</p> <p>Telescoping Square Telespar 592</p> <p>Telespar 594</p> <ul style="list-style-type: none"> Anchors Telespar 592 Barricade Repair Hardware Telespar 595 Brackets Telespar 594 Connector Brackets Telespar 594 Fasteners Telespar 594 Kleen Break Telespar 593 Multi-Directional Slip Base Components Telespar 593 Slip Base Bottom/Anchor Telespar 593 Telescoping Square Telespar 592 Telespar 594 Tubular Winged Anchors Telespar 592 <p>Telespar Caps & Crosses 594</p> <p>Telestrut Tubings 448</p> <p>Telpro</p> <ul style="list-style-type: none"> Drywall 225 Drywall Carts 225 Extensions 225 <p>Temporary Anchorage Connectors</p> <ul style="list-style-type: none"> Carabiner Temporary Anchorage Connectors 308 <p>Temporary Light Strings 429</p> <p>Temporary Power Cords 434</p>
---	--	--



<p>Tennsco Ventilated Lockers 622</p> <p>Tension Holdowns 550</p> <p>Terminal Crimpers 198</p> <p>Test Hydrostatic 151, 152</p> <p>Thawers Pipe Thawers 144</p> <p>The Squincher Corp. Drinks Electrolyte 333, 620 Electrolyte Drinks 333, 619, 620</p> <p>The Wind Clip Company Propane Torch 610 Wind Clips 597</p> <p>Thermostat Gloves 322</p> <p>Thimbles Wire Rope Thimbles 229</p> <p>Thread Cutting Oils 137</p> <p>Thread Tapping Tools 203</p> <p>Threaded Rod 494</p> <p>Threaded Rod Assemblies 546</p> <p>Threaded Rods 466</p> <p>Threaded Studs 545, 546</p> <p>Threader Die Heads 138, 139</p> <p>Threaders Geared Threaders 136 Power Drive Threaders 137 Power Threaders 137, 139, 140 Ratchet and Handle Threaders 135 Ratchet Threaders 135 Receding Threaders 136 Threader Die Heads 138, 139 Universal Die Heads 138</p> <p>Threading Machine Die Heads 136</p> <p>Threading Machines 138, 139 Compact Threading Machines 154</p> <p>Three Square Files 272</p> <p>Tie Down Straps 344</p> <p>Tie Downs Ratchet Tie Downs 217</p> <p>Tie Strap Holder Assemblies 547</p> <p>Tie Wire 396</p> <p>Tie-Off Adapters 300</p> <p>Ties Wall Ties 505</p> <p>Tie-Wire Reels 203</p> <p>Tiger Saws 92</p> <p>Tile Blades 385, 386</p> <p>Tilt Truck Standard Duty Tilt Truck 231</p> <p>Tinner Snips 266</p> <p>Tips No Mar Tips 539</p>	<p>Tires Wheelbarrow Tires 371</p> <p>Titanium Hammers 278</p> <p>Toe Jacks 229</p> <p>Toggle Bolts 520</p> <p>Toggle Sammys 526</p> <p>Tolco 473, 474, 475, 476, 477, 478, 479, 480, 481, 482, 483, 484, 485, 486</p> <p>Tongue & Groove Pliers 261</p> <p>Tool Bags 338, 339, 340</p> <p>Tool Bars 204</p> <p>Tool Belts 341, 342</p> <p>Tool Boxes 236, 237</p> <p>Tool Bucket Seats 342</p> <p>Tool Buckets 201, 202</p> <p>Tool Cabinets 233</p> <p>Tool Chest Trays 235</p> <p>Tool Chests 232, 233, 235, 236</p> <p>Tool Holders 202, 343</p> <p>Tool Kits Detection Tool Kits 45 Expansion Tool Kits 41, 45</p> <p>Tool Lanyard 304, 309</p> <p>Tool Pouches 202, 340</p> <p>Tool Sets Geared Box Tool Sets 256, 257 Hydraulic Tool Sets 226</p> <p>Tools Concrete Chisels 99 Deburring Tools 135, 151 Fastening Tools 543 Flaring Tools 143 Step Tools 393 Swaging Tools 228</p> <p>Tools Dispensing 517</p> <p>Top Hat Pins 542, 545</p> <p>Torch Propane Torch 610</p> <p>Torches Propane Torches 159</p> <p>Torpedo Levels 413, 414, 415, 416</p> <p>Torque Wrenches 128, 259</p> <p>Tow Straps 218</p> <p>Towel Wipers 330</p> <p>TPI Corporation Direct Drive Fans 365, 621 Floor Fans 365, 621 Milkhouse Heaters 366, 616 Portable Blowers 365, 621 Radiant Heaters 366, 616</p> <p>Track Saws 30</p>	<p>TracRac, Inc. Truck Racks 243</p> <p>Traction Boots 325, 618</p> <p>Traffic Cones 330</p> <p>Traffic Paddles 331</p> <p>Transfer Tanks 239</p> <p>Trash Bags Trash 615</p> <p>Trash Cans 612</p> <p>Trash Pumps 364</p> <p>Trauma Safety Strap 301, 304</p> <p>Trays Tool Chest Trays 235</p> <p>Tray-Type Sheaves 186</p> <p>Treatments Concrete Foundation 404</p> <p>Trench Shovels 287</p> <p>Trenching Shovels 288, 291</p> <p>Triangles Weighted Base Triangle Kits 331</p> <p>Tri-Flow 588</p> <p>Trim Saws 67</p> <p>Trimmers Laminate Trimmers 90, 91</p> <p>Tripod Ladders 206</p> <p>Tri-Pod Manifolds 609</p> <p>Tripods Aluminum Tripods 412</p> <p>Triumph Twist Drill Co. Alignment Reamers 274 Carbon Steel Dies 272, 273 Carbon Steel Taps 273, 274 Combination Drills 116 Combination Taps 274 Double End Drills 114 Extra Length Drills 113 High Speed Steel Taps 273 Jobber Drills 111, 112, 114, 115, 116 Reduced Shank Drills 113 Screw Extractors 274 Screw Machine Length Drills 112 Tap Wrenches 274</p> <p>Trolleys Wheel Trolleys 459</p> <p>Trollies Standard Duty Trollies 231 Wide Range Trollies 219</p> <p>Trouble Lights 426 Trouble Lights 426</p> <p>Trowel Handles 391</p> <p>Trowels Bricklaying Trowels 393</p>
--	--	---



<p>Finishing Trowels 393 Fresno Trowels 394 Gas Trowels 394 Margin Trowels 393, 394 Midget Trowels 393 Notched Trowels 394 Square Ornamental Trowels 393 Truck Boxes 237, 238, 239, 240 Truck Racks 243 Trucks Industrial Tilt Truck 231 Pallet Trucks 230 Truss Hangers 552 Try Squares 415 T-Squares Drywall T-Squares 415 Tsurumi Pumps Utility Pumps 364 Tube Benders 143, 170 Tube Spreaders 227 Tubing Benders 143 Tubing Clamps 461 Tubing Cutter Wheels 150 Tubing Cutters 46, 133, 134 Tubings Telestrut Tubings 448 Tubular Steel Hammers 278 Tubular Winged Anchors Telespar 592 Tuckpoint Blades 383, 384 Tuggers Power Tuggers 185 Tungsten Carbide Blades 103 Turbo Saw Blades 379, 381 Tuthill DC Pumps 241 Hand Pumps 240 Twin Front Ladders 205 Twist Straps 553 Two-Way Radios 333</p> <p>U U Shape Fittings 454, 455 Ultra Plastic Pipe Devices 580 Union Tools 618, 619 Asphalt Rakes 286 Bow Rakes 285 Concrete Rakes 284 Contractor Grade Wheelbarrows 370 Crow Bars 284 Dual Wheel Wheelbarrows 370</p>	<p>Grain Scoops 288 Irrigation Shovels 286 Landscape Rakes 285 Lawn Rakes 285 Material Scrapers 286 Morter Hoes 285 Pick Mattocks 285 Post Hole Bars 284 Post Hole Diggers 284 Pulaski Axes 285 Railroad Picks 285 Roofers Shovels 286 Round Point Shovels 286, 287 San Angelo Bars 284 Sidewalk/Ice Scrapers 286, 619 Sledge Hammers 288, 289 Square Point Shovels 287 Stone Rakes 286 Trench Shovels 287 Trenching Shovels 288 Wrecking Bars 284 Unistrut 444, 445, 446, 447, 455, 456, 457, 460, 463, 464, 466, 467 Angle Fittings 452, 453, 454, 465 Beam Clamp Straps 457, 461 Beam Clamps 457, 458, 459 Channel Fittings 466 Channel Joiners 463 Channel Nuts 448, 449, 463, 465 Clevis Hangers 466 Closure Strips 447 Concrete Inserts 464 Conduit Clamps 460, 461 Cradle Clips 450 Electrical Channels 464 End Caps 447, 448, 463, 464 End Connectors 463 Flat Plate Fittings 450, 451, 452 Gasketed Fittings 453 Hanger Connectors 462 Hex Nuts 449 Hinge Fittings 459, 460 Interlock Grating 466, 467 Joint Covers 464 Lock Washers 449 Mounting Brackets 457 Pipe Clamps 461, 462, 466 Pipe Rollers 462 Pipe Supports 462 Receptacle Covers 463 Round Hole Channels 444 Slotted Channels 465</p>	<p>Solid Channels 444, 445, 446, 447, 464, 465 Swivel Hangers 463 Telestrut Tubings 448 Threaded Rods 466 Tubing Clamps 461 U Shape Fittings 454, 455 Wheel Trolleys 459 Wing Shape Fittings 455 Z Shape Fittings 454 Universal Die Heads 138 Universal Joints 250, 253, 254, 255 Universal Padlocks 602 Upright Brooms 614 Utility Bars 280 Utility Carts 183, 231 Utility Knife Blades 271 Utility Knives 269, 270, 271 Utility Locators 146 Utility Pumps 364 Utility Vises 283 Uvex by Honeywell Anti-Fog Cloth 317 Eyeglass Cases 317 Eyeglass Hang Cords 317 Lens Cleaners 317 Safety Glasses 316, 317 Safety Goggles 317</p> <p>V Vaccums Dust Extractor Vaccums 83 Filter Vaccums 83 Vacuum Filter Bags Vacuum 84 Hepa Vacuums 84 Vacuums 84 Vacuum Filter Bags 86 Vacuum Filters 85, 86 Vacuum Hose Converters 86 Vacuum Hose Couplings 86 Vacuum Hoses 86 Vacuum Pumps Rigs 372 Vacuums 84 Canister Vacuums 84 Dust Extractor Vacuums 83 Filter Vacuums 83 Wet/Dry Vacuums 22, 85, 86 Valve Keys 153 Valve Wheel Wrenches 154 Vapor Retarders 397, 596, 597 Variable Speed Shears 75, 76</p>
---	---	---



<p>Variable-Speed Bench Drill Presses 88</p> <p>Variable-Speed Grinders 89</p> <p>Variable-Speed Lathes 88</p> <p>Variable-Speed Sanders 90</p> <p>Vaughan & Bushnell Mfg.</p> <ul style="list-style-type: none"> Ball Pein Hammers 278 Bricklayer Sets 280 Construction Hammers 279 Double Face Hammers 278 Electrician Hammers 278 Fiberglass Hammers 278 Framing Hammers 277 Nail Pullers 279, 280 Prospecting Picks 279 Pry Bars 279 Rip Hammers 277, 278 Ripping Bars 279 Rubber Mallets 278 Scraper Bars 279 Split-Head Hammers 279 Steel Hammers 277 Titanium Hammers 278 Tubular Steel Hammers 278 Wrecking Bars 280 <p>Vehicle Chargers 22</p> <p>Vehicle Chests 235</p> <p>Vehicle Drawers 242</p> <p>Vehicle Ladder Racks 243</p> <p>Vehicle Underbed Boxes 234</p> <p>Ventilated Lockers 622</p> <p>Ventilation Ducts 367</p> <p>Vest Harnesses 294</p> <p>Vests</p> <ul style="list-style-type: none"> Hi-Vis Vests 296 Reflective Vests 326, 327 Safety Vests 326 <p>Vibrator Heads 395, 396</p> <ul style="list-style-type: none"> Vibrator Heads 396 <p>Vibrator Motors 394, 396</p> <p>Vibrator Shafts 394, 396</p> <p>Vinyl Coated Sinkers 534</p> <p>Vinylex</p> <ul style="list-style-type: none"> Joint Water Stops 409 <p>Vise Drill Presses 88</p> <p>Vise Grip</p> <ul style="list-style-type: none"> See Irwin <p>Vises</p> <ul style="list-style-type: none"> Bench Chain Vise 129 Chain Vises 129 Combination Bench & Pipe Vise 142 Pipe Vises 128, 129, 151 	<p>Portable Tristand Vise 129</p> <p>Vises 283</p> <p>Visqueen</p> <ul style="list-style-type: none"> Roll Visqueen 596 <p>Volex 124, 125</p> <ul style="list-style-type: none"> 3 Wire 124 <p>Voltage Detectors 181</p> <p>W</p> <p>Walking Groovers 390</p> <p>Wall Jacks 213</p> <p>Wall Scrapers 269</p> <p>Wall Standoff Ladders 208</p> <p>Wall Ties 505</p> <p>Wallboard Anchors 520, 521</p> <p>Wallboard Saws 293</p> <p>Wall-Form Lanyards 298</p> <p>Warner Tool</p> <ul style="list-style-type: none"> Aluminum Bench 208 Drywall Bench 225 Halogen, Quartz Light Bulb 429 Magnetic Worklight 429 <p>Warning Flags 331</p> <p>Washers</p> <ul style="list-style-type: none"> Fender Washers 495 Flat Washers 495 Lock Washers 449, 495 <p>Washers Accessories 606</p> <p>Water 363</p> <ul style="list-style-type: none"> Water 363 <p>Water Coolers</p> <ul style="list-style-type: none"> Water Coolers Drinks 332, 333, 620 <p>Water Coolers Drinks 332, 333, 620</p> <p>Waxes</p> <ul style="list-style-type: none"> Stick Waxes 97 <p>WD-40 Co.</p> <ul style="list-style-type: none"> Spray Applicators 591 Spray Lubricants 591 <p>WEATHER GUARD Truck & Van</p> <ul style="list-style-type: none"> Equipment 238, 241, 242, 243 Transfer Tanks 239 Truck Boxes 237, 238, 239, 240 Vehicle Drawers 242 <p>Web Lanyards 304</p> <p>Web Slings 217</p> <p>Wedge Anchors 509, 510, 511, 516</p> <p>Wedge-Bolt Anchors 515</p> <p>Wedges</p> <ul style="list-style-type: none"> Stock Wedges 361 <p>Weighted Base Triangle Kits 331</p> <p>Weld Metals</p>	<p>Grounding Weld Metals 189</p> <p>Welders Boxes 235</p> <p>Welding Clamps 157, 263</p> <p>Werner Co. 209</p> <ul style="list-style-type: none"> Folding Ladders 208 Scaffold Platforms 210, 213, 214 <p>Western Scoops 290</p> <p>Wet Cutting Kits 375</p> <p>Wet/Dry Vacuums 22, 85, 86</p> <p>Wheel Brushes 558</p> <p>Wheel Chocks 331</p> <p>Wheel Sanders 64</p> <p>Wheel Trolleys 459</p> <p>Wheelbarrow Tires 371</p> <p>Wheelbarrows</p> <ul style="list-style-type: none"> Contractor Grade Wheelbarrows 370 Dual Wheel Wheelbarrows 370 <p>Wheels</p> <ul style="list-style-type: none"> Abrasive Wheels 66 Bench Wheels 567 Chop Saw Wheels 66 Cup Wheels 382, 567, 568 Cut-Off Wheels 568, 569, 570 Cutter Wheels 131, 133 Flap Wheels 564 Grinding Wheels 570, 571, 572 Measuring Wheels 416, 417 Pipeliners Wheels 572 Replacement Wheels Pipe Cutters 131 Ring Wheels 572 Tubing Cutter Wheels 150 <p>White Lightning Caulks & Sealants 588</p> <ul style="list-style-type: none"> Adhesive Caulks 582 Insulating Foams 588 Silicone Sealants 582 <p>Wide Crown Staples 540</p> <p>Wide Range Trollies 219</p> <p>Winch</p> <ul style="list-style-type: none"> Electric Winch 232 <p>Wind Clips 597</p> <p>Windows</p> <ul style="list-style-type: none"> Faceshield Windows 316 <p>Wing Shape Fittings 455</p> <p>Winter Liners 314, 617, 618</p> <p>Wipers</p> <ul style="list-style-type: none"> Reinforced Wipers 590 Towel Wipers 330 <p>Wipes</p> <ul style="list-style-type: none"> Cleaning Wipes 321, 590
--	--	---

<p>Hand Wipes 590</p> <p>Wire 518</p> <p>Ceiling Wire 491</p> <p>Tie Wire 396</p> <p>Wire 518</p> <p>Wire Brooms 613</p> <p>Wire Brushes 557, 614</p> <p>Wire Caddies 183</p> <p>Wire Carts 183</p> <p>Wire Crimpers 198</p> <p>Wire Dispensers 183</p> <p>Wire Hangers 491</p> <p>Wire Hook Portable/Temp Anchorage Connectors 307</p> <p>Wire Reel Pads 203</p> <p>Wire Rope Clips 228</p> <p>Wire Rope Grips 224</p> <p>Wire Rope Thimbles 229</p> <p>Wire Screens 499</p> <p>Wire Strippers 161, 197, 198</p> <p>Wire Tackers 281</p> <p>WMH Tool Group 79</p> <p>Ball Pein Hammers 290</p> <p>C- Clamps 284</p> <p>Mechanics Vises 283</p> <p>Sledge Hammers 290</p> <p>Utility Vises 283</p> <p>Wobblelight</p> <p>See ProBuilt</p> <p>Wood Bit Extensions 117</p> <p>Wood Bits 117</p> <p>Wood Boring Bits 169</p> <p>Wood Chisels 292</p> <p>Wood Handle Hookaroons 371</p> <p>Wood Handles 391</p> <p>Wood Rules 419</p> <p>Wood Sammys 521, 522</p> <p>Wood Working 533</p> <p>Wood Working 533</p> <p>Woodboring Bits 117</p> <p>Woodhead</p> <p>Control 437</p> <p>Hand Lamps 436</p> <p>Industrial Connectors 436</p> <p>Industrial Plugs 436</p> <p>Industrial-Duty Adapters 436</p> <p>Industrial-Duty Outlet Box 436</p> <p>Industrial-Duty Reels 437</p> <p>Industrial-Duty Sockets 436</p> <p>Work Benches 234, 236</p> <p>Work Gloves 324, 325</p> <p>Work Light Lighting 43</p>	<p>Work Lights 48, 426, 428</p> <p>Work Suspenders 343</p> <p>Worklight</p> <p>Magnetic Worklight 429</p> <p>Worktables</p> <p>Portable Worktables 237</p> <p>Worm Drive Saws 67</p> <p>Wraps</p> <p>Duct Wraps 579</p> <p>Fire Barrier Wraps 579</p> <p>Strips Wrap 574</p> <p>Wrecking Bars 280, 284</p> <p>Wrench</p> <p>Midget Combination Wrench 257</p> <p>Wrench Knockouts 163, 185</p> <p>Wrenches</p> <p>Adjustable Wrenches 201, 262</p> <p>Basin Wrenches 128</p> <p>Box End Wrenches 126</p> <p>Chain Wrenches 127</p> <p>Combination Wrenches 257, 258</p> <p>Construction Wrenches 259</p> <p>Erection Wrenches 201</p> <p>Hex Wrench 126</p> <p>Impact Wrenches 18, 26, 27, 32, 33, 47, 52, 57, 62, 350</p> <p>Internal Wrenches 127</p> <p>Long Pattern Wrenches 259</p> <p>Pipe Wrenches 126, 128</p> <p>Ratchet Wrenches 163, 165</p> <p>Ratcheting Wrenches 201</p> <p>Short Combination Wrench 257</p> <p>Short Pattern Wrenches 259</p> <p>Spring Loaded Jaw Basin Wrench 128</p> <p>Spud Wrenches 127</p> <p>Strap Wrenches 127</p> <p>Tap Wrenches 274</p> <p>Torque Wrenches 128, 259</p> <p>Valve Wheel Wrenches 154</p> <p>X</p> <p>X Cables 191</p> <p>Xcessories Squared 355, 595</p> <p>Anchors Telespar 592</p> <p>Barricade Repair Hardware Telespar 595</p> <p>Brackets Telespar 594</p> <p>Connector Brackets Telespar 594</p> <p>Fasteners Telespar 594</p> <p>Kleen Break Telespar 593</p>	<p>Multi-Directional Slip Base Components Telespar 593</p> <p>Slip Base Bottom/Anchor Telespar 593</p> <p>Telespar 594</p> <p>Telespar Caps & Crosses 594</p> <p>Tubular Winged Anchors Telespar 592</p> <p>X-Press It Sammys 525</p> <p>Y</p> <p>Yaktrax 619</p> <p>Traction Boots 325, 618</p> <p>Yamaha Motor Corp.</p> <p>Generator Accessories 350</p> <p>Portable Generators 348, 349</p> <p>Z</p> <p>Z Shape Fittings 454</p> <p>Zip Slotted 531</p> <p>Zipper</p> <p>Adhesive Zipper 598</p> <p>Zipwall, LLC</p> <p>Dust Barriers Systems 599, 600</p>
---	--	---



3M15A.....	579	AJ315-24.....	360	AL10162.....	493	AL12588.....	494	AL31763.....	495
3M2000.....	578	AJ32100.....	360	AL10164.....	493	AL12620.....	494	ALL9500-01.....	366
3M2HA.....	580	AJ32200.....	360	AL10168.....	493	AL12622.....	494	ALL9500-03.....	367
3M2MCID.....	580	AJ32300.....	360	AL10172.....	493	AL12624.....	494	ALL9500-25.....	367
3M2MDA.....	580	AJ323-12.....	360	AL10176.....	493	AL12628.....	494	ALL9514-25.....	366
3M2PCID.....	580	AJ323.....	360	AL10180.....	493	AL12632.....	494	ALL9533-25.....	367
3M2TB.....	580	AJ325-12.....	360	AL10184.....	493	AL12636.....	494	ALL9538-25.....	367
3M3HA.....	580	AJ325-18.....	360	AL10188.....	493	AL12640.....	494	AN13-938.....	254
3M3MCID.....	580	AJ325.....	360	AL10192.....	493	AL12644.....	494	AN56014.....	276
3M3MDA.....	580	AJ382.....	359	AL10328.....	493	AL12648.....	494	AN56015.....	276
3M3PCID.....	580	AJ383.....	359	AL10330.....	493	AL12652.....	494	AN56026.....	277
3M3TB.....	580	AJ38400.....	360	AL10332.....	493	AL12656.....	494	AN56030.....	276
3M4HA.....	580	AJ384.....	359	AL10336.....	493	AL12660.....	494	AN56064.....	277
3M4MCID.....	580	AJ39500.....	360	AL10340.....	493	AL12712.....	494	AN56074.....	276
3M4MDA.....	580	AJ41200.....	360	AL10344.....	493	AL12716.....	494	AN56076.....	276
3M4PCID.....	580	AJ41758.....	361	AL10348.....	493	AL12720.....	494	AN56122.....	276
3M6MCID.....	580	AJ42100.....	360	AL10352.....	493	AL12724.....	494	AN56346.....	276
3M6PCID.....	580	AJ42200.....	360	AL10356.....	493	AL12728.....	494	AN56897.....	276
3M77.....	588	AJ42300.....	360	AL10360.....	493	AL12732.....	494	AN56900.....	276
3MCP25WB-27.....	578	AJ43100.....	360	AL10364.....	493	AL12736.....	494	AN57020.....	277
3MCP25WB-5.....	578	AJ43300.....	360	AL10368.....	493	AL12740.....	494	AN57022.....	277
3MCP25WB.....	578	AJ47200.....	360	AL10372.....	493	AL12744.....	494	AN57026.....	277
3MCS-195-3X2.....	579	AJ48400.....	360	AL10376.....	493	AL12748.....	494	Angled Base.....	456
3MCS-195-3X3.....	579	AJ49500.....	360	AL10380.....	493	AL12828.....	494	AP320-3*X.....	120
3MCS-195-3X41.....	579	AJ5009.....	360	AL10384.....	493	AL12832.....	494	AP320-4*X.....	120
3MFB249.....	579	AJ5012.....	360	AL10392.....	493	AL12836.....	494	AP320-5*X.....	120
3MFB269.....	579	AJ5016.....	361	AL10400.....	493	AL12844.....	494	AP326-3*X.....	120
3MFB369.....	579	AJ5209.....	360	AL10416.....	493	AL12852.....	494	AP440-1*X.....	120
3MFD150+28BLUE.....	578	AJ5218.....	360	AL10496.....	493	AL19232.....	493	AP440-2*X.....	120
3MFD150+4.5LIMESTONE.....	578	AJ5220.....	361	AL10500.....	493	AL19236.....	493	AP440-3*X.....	120
3MFD150+BLUE.....	578	AJ5801.....	361	AL10502.....	493	AL19240.....	493	AP440-TX-05*X.....	121
3MFD150+LIMESTONE.....	578	AJ5803.....	361	AL10504.....	493	AL19302.....	493	AP440-TX-08*X.....	121
3MFIREDAM 150+4.5.....	578	AJ5805.....	361	AL10508.....	493	AL19306.....	493	AP440-TX-10*X.....	121
BLUE.....	578	AJ5816.....	361	AL10512.....	493	AL30004.....	494	AP440-TX-15*X.....	121
3M FIREDAM SPRAY 200.....	579	AJ5820.....	361	AL10516.....	493	AL30005.....	494	AP440-TX-20*X.....	121
3MFS-195.....	579	AJ592.....	361	AL10520.....	493	AL30006.....	494	AP440-TX-25*X.....	121
3MIC15WB.....	578	AJ675-12.....	361	AL10524.....	493	AL30008.....	494	AP440-TX-27*X.....	121
3MMINERALWOOL.....	574	AJ675-18.....	361	AL10528.....	493	AL30010.....	494	AP440-TX-30*X.....	121
3MMORTAR.....	579	AJ682.....	361	AL10532.....	493	AL30012.....	494	AP440-TX-40*X.....	121
3MMPP+.....	578	AJ882.....	361	AL10536.....	493	AL30014.....	494	AP440-TX-45*X.....	121
3MMPP+9.....	578	AJ884.....	361	AL10540.....	493	AL30016.....	494	AP440-TX-50X.....	121
3MPPS-2+.....	578	AJ907.....	359	AL10544.....	493	AL30020.....	494	AP445-0X.....	120
3MRC-1.....	579	AJ908.....	359	AL10552.....	493	AL30452.....	494	AP445-10*X.....	120
3MULTRAPPD1.5.....	580	AJ909.....	359	AL10556.....	493	AL30454.....	494	AP445-1*X.....	120
3MULTRAPPD2.0.....	580	AJ910-1/2.....	359	AL10560.....	493	AL30456.....	494	AP445-20*X.....	120
3MULTRAPPD3.0.....	580	AJ910.....	359	AL10568.....	493	AL30458.....	494	AP445-2*X.....	120
3MULTRAPPD4.0.....	580	AJ911.....	359	AL10584.....	493	AL30853.....	494	AP445-3*X.....	120
5/16.....	197	AJ913.....	359	AL10664.....	493	AL30855.....	494	AP445-4*X.....	120
542756100.....	376	AJ922.....	359	AL10670.....	493	AL30856.....	494	AP446-1*X.....	120
542756105.....	376	AL10004.....	493	AL10674.....	493	AL30857.....	494	AP446-2*X.....	120
542756112.....	376	AL10006.....	493	AL10682.....	493	AL30858.....	494	AP480-2*X.....	120
542756137.....	376	AL10008.....	493	AL10686.....	493	AL30859.....	494	AP480-3*X.....	120
542756164.....	376	AL10010.....	493	AL10690.....	493	AL30861.....	494	AP480-TX-30*X.....	121
542777005.....	376	AL10012.....	493	AL10694.....	493	AL30862.....	494	AP480-TX-40*X.....	121
A260-8.....	469	AL10016.....	493	AL10698.....	493	AL30863.....	494	AP480-TX-50*X.....	121
ACL11500C.....	611	AL10018.....	493	AL10702.....	493	AL31026.....	495	AP491-A*X.....	120
ACL11509C.....	611	AL10020.....	493	AL10710.....	493	AL31027.....	495	AP491-B*X.....	120
ACL14500C.....	611	AL10024.....	493	AL10714.....	493	AL31028.....	495	AP491-C*X.....	120
ACL14509C.....	611	AL10028.....	493	AL10718.....	493	AL31029.....	495	AP491*X.....	120
ACL241750L.....	611	AL10032.....	493	AL10722.....	493	AL31031.....	495	AP492-A*X.....	120
ACL241759L.....	611	AL10036.....	493	AL10730.....	493	AL31033.....	495	AP492-B*X.....	120
ACL4180C.....	611	AL10040.....	493	AL10738.....	493	AL31035.....	495	AP492-C*X.....	120
ACL4189C.....	611	AL10044.....	493	AL10746.....	493	AL31037.....	495	AP492*X.....	120
ACL7500C.....	611	AL10048.....	493	AL10754.....	493	AL31039.....	495	AP493-A*X.....	120
ACL7509C.....	611	AL10056.....	493	AL10770.....	493	AL31095.....	495	AP493-B*X.....	120
AJ1377.....	360	AL10078.....	493	AL10904.....	493	AL31097.....	495	AP493*X.....	120
AJ1605.....	360	AL10080.....	493	AL10908.....	493	AL31098.....	495	AP49-A-TX-20.....	121
AJ1621.....	360	AL10082.....	493	AL10916.....	493	AL31301.....	495	AP49-A-TX-25.....	121
AJ22100.....	360	AL10084.....	493	AL10924.....	493	AL31302.....	495	AP950-0*X.....	121
AJ22200.....	360	AL10088.....	493	AL11052.....	493	AL31303.....	495	AP950-1*X.....	121
AJ23300.....	360	AL10092.....	493	AL11060.....	493	AL31304.....	495	AP950-2*X.....	121
AJ28400.....	360	AL10096.....	493	AL11076.....	493	AL31306.....	495	AP950-3*X.....	121
AJ30010.....	360	AL10100.....	493	AL11092.....	493	AL31308.....	495	AP954-1*X.....	121
AJ303-12.....	360	AL10104.....	493	AL12510.....	494	AL31310.....	495	AP954-2*X.....	121
AJ303-18.....	360	AL10108.....	493	AL12512.....	494	AL31312.....	495	AP954-3*X.....	121
AJ303-24.....	360	AL10112.....	493	AL12516.....	494	AL31314.....	495	AP954-A-1*X.....	121
AJ303.....	360	AL10116.....	493	AL12520.....	494	AL31320.....	495	AP954-A-2*X.....	121
AJ307.....	360	AL10120.....	493	AL12524.....	494	AL31323.....	495	AP954-A-3*X.....	121
AJ31060.....	360	AL10148.....	493	AL12528.....	494	AL31693.....	495	AP954-B-1*X.....	121
AJ31080.....	360	AL10150.....	493	AL12536.....	494	AL31707.....	495	AP954-B-2*X.....	121
AJ313.....	360	AL10152.....	493	AL12540.....	494	AL31709.....	495	AP954-B-3*X.....	121
AJ315-12.....	360	AL10154.....	493	AL12544.....	494	AL31711.....	495	AP954-C-2*X.....	121
		AL10156.....	493	AL12568.....	494	AL31749.....	495	AP954-C-3*X.....	121
		AL10158.....	493	AL12572.....	494	AL31751.....	495	APEX-250-2.....	122
		AL10160.....	493	AL12576.....	494	AL31759.....	495	APEX-250-3.....	122

Part Number Index

www.edgecs.com



APEX-250-6	122	AR12-122A	251	AR14-951	255	AR21-236	255	AR64-041	259
APEX-250-B-2	122	AR12-124A	251	AR15-246A	245	AR21-238	255	AR64-046	259
APEX-370-B	122	AR12-126A	251	AR15-248A	245	AR21-240	255	AR64-086	259
APEX-370-B-2	122	AR12-128A	251	AR15-321A	246	AR21-242	255	AR70-105	260
APEX-500-B-2	122	AR12-130A	251	AR15-322A	246	AR21-244	255	AR70-131	260
APM-490	121	AR12-132A	251	AR15-440	246	AR21-246	255	AR70-239	260
APM-490-2	121	AR12-134A	251	AR15-517A	247	AR21-248	255	AR70-309	260
APM-490-6	121	AR12-136A	251	AR15-518A	247	AR21-252	255	AR70-311	260
APMDA-08	122	AR12-140A	251	AR15-519A	247	AR21-893	248	AR70-313	260
APMDA-10	122	AR12-142	251	AR15-524A	245	AR21-923	255	AR70-507	260
APMDA-12	122	AR12-144	251	AR15-610	248	AR21-924	255	AR70-927	260
APMDB-08	122	AR12-146	251	AR19-895	246	AR21-947	255	AR70-929	260
APMDB-10	122	AR12-148A	251	AR20-012	253	AR21-951	255	AR70-933	260
APMDB-12	122	AR12-212	251	AR20-014	253	AR21-952	255	AR70-952	260
APMDB-14	122	AR12-216	251	AR20-016	253	AR21-964	255	AR70-954	260
AR11-008	248	AR12-220	251	AR20-018	253	AR21-965	255	AR70-958	260
AR11-010	248	AR12-226	251	AR20-020	253	AR21-967	255	AR70-970	260
AR11-012	248	AR12-244	251	AR20-022	253	AR22-951	256	AR78-402	261
AR11-014	248	AR12-312A	251	AR20-024	253	AR22-965	256	AR78-403	261
AR11-022	248	AR12-316A	251	AR20-026	253	AR25-004	257	AR78-404	261
AR11-028	248	AR12-318A	251	AR20-028	253	AR25-005	257	AR78-406	261
AR11-030	248	AR12-320A	251	AR20-030	253	AR25-006	257	AR78-408	261
AR11-032	248	AR12-322A	251	AR20-032	253	AR25-007	257	AR78-410	261
AR11-110A	249	AR12-324A	251	AR20-034	253	AR25-009	257	AR78-412	261
AR11-112A	249	AR12-326A	251	AR20-036	253	AR25-111	259	AT12B	494
AR11-114A	249	AR12-328A	251	AR20-038	253	AR25-112	259	AT12Z-12'	494
AR11-116A	249	AR12-330A	251	AR20-040	253	AR25-114	259	AT12Z	494
AR11-118A	249	AR12-332A	251	AR20-042	253	AR25-119	259	AT14Z	494
AR11-120A	249	AR12-334A	251	AR20-044	253	AR25-120	259	AT1Z	494
AR11-122A	249	AR12-336A	251	AR20-046	253	AR25-125	259	AT34B	494
AR11-124A	249	AR12-340A	251	AR20-048	253	AR25-126	259	AT34Z	494
AR11-126A	249	AR12-504	250	AR20-212	253	AR25-128	259	AT38B	494
AR11-128A	249	AR12-714	251	AR20-214	253	AR25-210	259	AT38Z-12'	494
AR11-212	249	AR12-715	251	AR20-216	253	AR25-211	259	AT38Z	494
AR11-214	249	AR12-716	251	AR20-218	253	AR25-212	259	AT58B	494
AR11-220	249	AR12-717	251	AR20-220	253	AR25-214	259	AT58HDG	494
AR11-222	249	AR12-718	251	AR20-222	253	AR25-216	259	AT58Z	494
AR11-224	249	AR12-719	251	AR20-224	253	AR25-218	259	AT78HDG	494
AR11-312A	249	AR12-909A	252	AR20-226	253	AR25-220	259	AT78Z	494
AR11-314A	249	AR12-915	252	AR20-228	253	AR25-222	259	AV112-1[1/4]	472
AR11-316A	249	AR12-917A	252	AR20-230	253	AR25-226	259	AV112-1	472
AR11-318A	249	AR12-921	252	AR20-232	253	AR25-228	259	AV113-1[1/4]	472
AR11-320A	249	AR12-923A	252	AR20-234	253	AR25-232	259	AV113-1	472
AR11-322A	249	AR12-924A	252	AR20-236	253	AR25-234	259	AV248B-1/2	472
AR11-324A	249	AR12-927	252	AR20-240	253	AR25-242	258	AV248B-3/4	472
AR11-326A	249	AR12-935A	252	AR20-242	253	AR25-242	259	AV248B-3/8	472
AR11-328A	249	AR12-938	252	AR20-244	253	AR25-244	258	AV248B-5/8	472
AR11-501	249	AR12-947A	253	AR20-246	253	AR25-246	258	AV248C-1/2	472
AR11-504	249	AR12-951	252	AR20-248	253	AR25-248	258	AV248C-3/4	472
AR11-708	249	AR12-952	252	AR20-574	253	AR25-252	258	AV248C-3/8	472
AR11-709	249	AR12-967A	251	AR20-580	253	AR25-254	258	AV248C-5/8	472
AR11-710	249	AR12-972	251	AR20-889	247	AR25-256	258	AV260-10	469
AR11-711	249	AR12-973	252	AR20-893	248	AR25-258	258	AV260-10	470
AR11-712	249	AR12-974	252	AR20-895A	248	AR25-260	258	AV260-1[1/2]	469
AR11-713	249	AR12-974A	252	AR20-897	248	AR25-264	258	AV260-1[1/4]	469
AR11-714	249	AR12-990	253	AR20-923	253	AR25-268	258	AV260-1/2	469
AR11-715	249	AR13-126	254	AR20-924	253	AR25-272	258	AV260-12	469
AR11-918	250	AR13-128	254	AR20-947	254	AR25-276	258	AV260-12	470
AR11-921	250	AR13-130	254	AR20-952	254	AR25-280	258	AV260-14	469
AR11-922A	250	AR13-132	254	AR21-024	255	AR25-484	258	AV260-14	470
AR11-923A	250	AR13-134	254	AR21-026	255	AR25-486	258	AV260-1	469
AR11-925A	250	AR13-136	254	AR21-028	255	AR25-490	258	AV260-16	469
AR11-927	250	AR13-138	254	AR21-030	255	AR25-600	257	AV260-16	470
AR11-935	250	AR13-140	254	AR21-032	255	AR25-607	257	AV260-18	469
AR11-938	250	AR13-142	254	AR21-034	255	AR25-608	257	AV260-20	469
AR11-947	250	AR13-144	254	AR21-036	255	AR25-611	257	AV260-2[1/2]	469
AR11-951	250	AR13-146	254	AR21-038	255	AR27-609	256	AV260-24	469
AR11-952A	250	AR13-148	254	AR21-040	255	AR27-708	257	AV260-2	469
AR11-967A	249	AR13-150	254	AR21-042	255	AR30-308	258	AV260-2	470
AR11-974A	249	AR13-152	254	AR21-044	255	AR30-310	258	AV260-30	469
AR12-014	250	AR13-154	254	AR21-046	255	AR30-312	258	AV260-3[1/2]	469
AR12-016	250	AR13-156	254	AR21-048	255	AR30-314	258	AV260-3/4	469
AR12-018	250	AR13-158	254	AR21-052	255	AR30-316	258	AV260-3	469
AR12-020	250	AR13-160	254	AR21-054	255	AR30-318	258	AV260-3	470
AR12-022	250	AR13-164	254	AR21-056	255	AR30-320	258	AV260-4	469
AR12-026	250	AR13-168	254	AR21-058	255	AR30-322	258	AV260-4	470
AR12-028	250	AR13-172	254	AR21-060	255	AR30-324	258	AV260-5	469
AR12-032	250	AR13-918	254	AR21-062	255	AR30-326	258	AV260-5	470
AR12-034	250	AR13-922	254	AR21-064	255	AR30-328	258	AV260-6	469
AR12-040	250	AR13-923	254	AR21-224	255	AR30-330	258	AV260-6	470
AR12-112A	251	AR13-925	254	AR21-226	255	AR30-332	258	AV260-8	470
AR12-114A	251	AR13-951	254	AR21-228	255	AR32-824	259	AV284A-1/2	472
AR12-116A	251	AR13-952	254	AR21-230	255	AR44-326A	246	AV284A-3/4	472
AR12-118A	251	AR13-972	254	AR21-232	255	AR44-516A	247	AV284A-3/8	472
AR12-120A	251	AR13-990	254	AR21-234	255	AR52-606	257	AV284A-5/8	472

Spokane, WA 509-535-9841

Billings, MT 406-248-7196



AV292-1	471	BO1821	69	BZTS3000T	159	CD400PLUSF20	189	CDVSC-2Q	192
AV292-2	471	BO1942	70	BZTS4000T	159	CD45	189	CDVSC-3Q	192
AV292-3	471	BO1944LCDK	70	BZTS99T	159	CD45PLUSF20	190	CDXAC-2L2L	192
AV292-4	471	BO290-01	75	BZTX405	159	CD500	189	CDXAC-2Q2Q	191
AV292-5	471	BO290-KIT	75	BZTX406	159	CD500PLUSF20	189	CEP1330FT	426
AV292-6	471	BOBAT021	67	BOBAT9	159	CD613480	190	CEP3110	426
AV292-7	471	BOBAT240	67	BZUL125	159	CD65	189	CEP3111	426
AV292-8	471	BOBC004	67	CA1226TI	489	CD65PLUSF20	190	CEP3115	426
AV292L-1	471	BOHPT101D	105	CA16M24	488	CD815880	190	CEP3116	426
AV292L-2	471	BOJS365	68	CA16M24SM	488	CD90	189	CEP5050	426
AV292L-3	471	BORS35	67	CA16M58	488	CD90PLUSF20	189	CEP5125-I	426
AV292L-4	471	BOT101A0	105	CA20M24	488	CD90PLUSF20	190	CEP5610-I	426
AV292L-5	471	BOT101A	105	CA2H4	488	CDGR1141GPLUS	193	CEP5650-I	426
AV292L-6	471	BOT101B	105	CA304B2	489	CDGR1141LPLUS	193	CEP5710	426
AV292L-7	471	BOT101BF	105	CA4H24	488	CDGR1141VPLUS	193	CEP5750	426
AV292L-8	471	BOT101BR	105	CA4H58	488	CDGR1161GPLUS	193	CEP5911	426
AW8000	281	BOT101DP	105	CA4TIB	491	CDGR1161LPLUS	193	CEP6210DC	427
AWHT50A	281	BOT111C	105	CA512HD	491	CDGR1162CPLUS	193	CEP6210PDC30	427
AWT25M	281	BOT111CF	105	CA515A	489	CDGR1162GPLUS	193	CEP6211DC	427
AWT50M	281	BOT113A3	105	CA6M	488	CDGR1162QPLUS	193	CEP6212PDC30	427
BAT181	67	BOT118A	105	CA6TB	491	CDGR1181GPLUS	193	CEP6214PDC15	427
BAT411	67	BOT118AF	105	CA6TI24	489	CDGR1181LPLUS	193	CEP6220CC	427
BCTW16	396	BOT118B	105	CA6TI	491	CDGR1181VPLUS	193	CEP6220PDC45	427
BF10105	615	BOT118EF	105	CA6TI58	489	CDGR1182CPLUS	193	CEP6220PDC75	427
BF25C	615	BOT118G	105	CA6TIB	491	CDGR1182GPLUS	193	CEP6221CC	427
BF25SS	615	BOT119BO	105	CA740	489	CDGR1182QPLUS	193	CEP6221PDC75	427
BF25W	615	BOT119BO3	105	CA781	489	CDGRC-182Q	190	CEP6240CC	427
BF50C	615	BOT11G	105	CA812M24	488	CDGT1141GPLUS	193	CEP6240PDC150	427
BF5C	615	BOT123X	105	CA812M24SM	488	CDGT1141LPLUS	193	CEP6241PC	427
BF90850	336	BOT127D	105	CA812M4I	488	CDGT1141VPLUS	193	CEP6241PDS150	427
BF90850	615	BOT127DF	105	CA812MB18	489	CDGT1161GPLUS	193	CEP8612	426
BF92000	615	BOT18A	105	CAAB	491	CDGT1161LPLUS	193	CFK610-027	332
BF92001	335	BOT211HF	105	CAAF14	489	CDGT1-161V	190	CFK610-028	332
BF92001	615	BOT218A	105	CABC	468	CDGT1161VPLUS	193	CFK610-029	332
BIO54-44-01	312	BOT318A	105	CACAT32AB	490	CDGT1162CPLUS	193	CFK610-030	332
BIO54-44-02	312	BOT318B	105	CACD1B	490	CDGT1162GPLUS	193	CFK610-033	332
BIO54-46-9000	313	BUPAT46C-LI	187	CACRLB37EG	468	CDGT1181GPLUS	193	CG0012C	283
BIO54-46-9000N	313	BUPAT644-LI	187	CACRLS37EG	468	CDGT1181LPLUS	193	CG0090MC	283
BIO54-46-9100	313	BUPAT644XT18V	187	CAESG1	490	CDGT1182CPLUS	193	CG0112C	283
BIO54-46-9100N	313	BUPAT750C-LI	186	CAIDS	489	CDGT1182GPLUS	193	CG0143226	228
BIO54-48-300	312	BUPAT750XT18V	187	CAK12	490	CDGTC-161T	190	CG0143326	228
BIO54-48-301	312	BUPAT81KFT18V	187	CAK16	490	CDGTC-161V	190	CG0143426	228
BIO54-48-302	312	BUPATCUT129ACSR18V	187	CAK20	490	CDGTC-162G	190	CG0180512	228
BIO54-48-314	312	187		CAK8	490	CDGTC-162Q	190	CG0190MC	283
BIO54-49-102	312	BUPATCUT245CUAL18V	187	CAKX	490	CDGTC-182Q	190	CG0190MTN	282
BIO54-49-9000	313	187		CAM24	488	CDL-160	191	CG0290MC	283
BIO54-49-9000N	313	BUPT29291	186	CAM24S	488	CDLAC-2QEK	189	CG0390MC	283
BIO54-53-A01025100	312	BUPU998	186	CAM58	488	CDLAC-3QEH	189	CG0513574	227
BIO54-53-A01028000	312	BUU1011	186	CAM58S	488	CDNCR-162G	190	CG0513665	227
BIO54-53-A02195080	312	BUU1104	186	CAMPLS	490	CDNT1141GPLUS	193	CG0590MC	283
BIO54-53-A02195100	312	BUU1105	186	CAMSR24	490	CDNT1141LPLUS	193	CG0590RBJ	282
BIO54-53-A02195280	312	BUU1CART	186	CAMSR58	490	CDNT1141VPLUS	193	CG066F	419
BIO54-53-A02198000	312	BUU1CRT-1	186	CAMSS24	490	CDNT1161GPLUS	193	CG0690TN	283
BIO54-53-A03148000	312	BUU25ART	186	CAMSS58	490	CDNT1161LPLUS	193	CG1066D	419
BIO54-53-A06148000	312	BUU25RT	186	CAPCS2	490	CDNT1-161V	190	CG1412C	283
BIO54-53-A09148000	312	BUU26ART	186	CARPS50H4EG	491	CDNT1161VPLUS	193	CG1490MC	283
BIO54-53-A10148000	312	BUU26RT	186	CARPS50H6EG	491	CDNT1181GPLUS	193	CG6130	282
BIO54-53-A1025080	312	BUU27ART	186	CASCH12	488	CDNT1181LPLUS	193	CG6140	282
BIO54-53-A1025280	312	BUU27RT	186	CASCH12B	488	CDNT1181VPLUS	193	CG6150	282
BIO54-53-A14008000	312	BUU28ART	186	CASCH16	488	CDPLUSCU	192	CG6160	282
BIO54-53-A14005100	312	BUU28RT	186	CASCH20	488	CDPTC-1T1T	191	CG6203604	229
BIO54-53-A14005280	312	BUU29ART	186	CASCH8	488	CDSSC-2G	191	CG6207803	228
BIO54-53-A14008000	312	BUU29RT	186	CASGB16A	488	CDSSC-2L	191	CG7000427	227
BIO54-53-A14158000	312	BUU2CABT	186	CASGB24A	488	CDSSC-2Q	191	CG7000627	227
BIO54-53-A14188000	312	BUU2CRT	186	CASK125I	490	CDT313	190	CG7000827	227
BIO54-53-A14218000	312	BUU30ART	186	CASN37	468	CDT-314	191	CG7250N	282
BIO54-54-9200	313	BUU30RT	186	CATSGB16	488	CDT320	191	CG7250W	282
BIO54-54-9200N	313	BUU31ART	186	CATSGB24	488	CDT320A	191	CG7679038	228
BIO54-54-9400	313	BUU31RT	186	CD115	189	CDT394	191	CGAL725	418
BIO54-54-9400N	313	BUU32ART	186	CD115PLUSF20	189	CDT403	191	CGAL725MAG	418
BO11224VSR	68	BUU32RT	186	CD115PLUSF20	190	CDTAC-1T1T	191	CGB7675324	228
BO11240	68	BUU34ART	186	CD150	189	CDTAC-1V1L	191	CGB7675344	228
BO11247	69	BUU34RT	186	CD150PLUSF20	189	CDTAC-2C2C	191	CGB7675354	228
BO11255VSR	68	BUU36ART	186	CD150PLUSF20	190	CDTAC-2G2G	191	CGC1286	419
BO11263EVS	69	BUU36RT	186	CD200	189	CDTAC-2Q2G	191	CGD550PK	282
BO11304K	69	BUU39ART-2	186	CD200PLUSF20	189	CDTAC-2Q2Q	191	CGFE100	419
BO1365K	69	BUU39RT	186	CD200PLUSF20	190	CDTAC-2S1K	189	CGFE100D	419
BO1462VS	68	BUU4CABT	186	CD250	189	CDTAC-2V2G	191	CGHV1048CM	418
BO1500C	69	BUU4CRT	186	CD250PLUSF20	189	CDTAC-4L2Q	189	CGHV1049CME	418
BO1529B	70	BUU5CRT	186	CD250PLUSF20	190	CDTAC-9J9J	189	CGHV1312D	419
BO1530	69	BUU6CABT	186	CD25	189	CDVFC-1T-V3C	192	CGHV1425	419
BO1534	70	BUU997	186	CD25PLUSF20	190	CDVSC-1T	192	CGHV1425D	418
BO161857114	70	BUUC	186	CD300PLUSF20	189	CDVSC-1T-V3C	192	CGL525	418
BO16185800	70	BUUO	186	CD32	189	CDVSC-2G	192	CGM1R	265
BO1677M	67	BZMG9	159	CD32PLUSF20	190	CDVSC-2L-V3C	192	CGM2R	265



Part Number Index

www.edgecs.com

CGM3R.....	265	CM2230.....	220	CM659228.....	223	CPCP 1230 SVR.....	353	CS135M.....	324
CGPS1806.....	419	CM2231.....	220	CM659229.....	223	CPCP 1240.....	353	CS135XL.....	324
CGPS1808.....	419	CM2233.....	220	CM659232.....	223	CPCP 1240 S.....	353	CS140L.....	324
CGPSFE100.....	419	CM2234.....	220	CM659235.....	223	CPCP 1240 SVR.....	353	CS140M.....	324
CGPSFE200.....	419	CM2262.....	220	CM659238.....	223	CPCP 14 RR.....	355	CS140XL.....	324
CGPSFE300.....	419	CM2263.....	220	CM659239.....	223	CPCP 185 PD.....	346	CS145L.....	324
CGRCT.....	282	CM2264.....	220	CM659430.....	223	CPCP 3.....	357	CS145M.....	324
CGT7670419.....	228	CM2272.....	220	CM664028-2.....	224	CPCP.....	353	CS145XL.....	324
CGT7670429.....	228	CM3302.....	219	CM664038-2.....	224	CPCP 4123 2H.....	356	CS147L.....	324
CGT7670439.....	228	CM3304.....	219	CM664050-2.....	224	CPCP 4123 2R.....	356	CS147M.....	324
CGT7670609.....	229	CM3306.....	219	CM664062-2.....	224	CPCP 4123 3H.....	356	CS147XL.....	324
CGT7670619.....	229	CM3307.....	219	CM664075-2.....	224	CPCP 4123 3R.....	356	CS1509.....	340
CGT7670629.....	229	CM4043.....	221	CM664089-2.....	224	CPCP 4123 4H.....	356	CS1517.....	343
CGW12MP.....	265	CM4045.....	221	CM664100-2.....	224	CPCP 4123 4R.....	356	CS1520.....	343
CGWC5S.....	266	CM4047.....	221	CM664125-2.....	224	CPCP 4125 2H.....	356	CS1521.....	343
CGWF18.....	266	CM4050.....	221	CM71497.....	223	CPCP 4125 2R.....	356	CS1526.....	338
CGWHN1.....	266	CM4071.....	221	CM72197.....	223	CPCP 4125 3H.....	356	CS1528.....	340
CGWS3.....	266	CM4072.....	221	CM81101.....	223	CPCP 4125 3R.....	356	CS1529.....	339
CGWS6.....	266	CM4096.....	221	CM81201.....	223	CPCP 4125 4H.....	356	CS1532.....	339
CH1949.....	399	CM4098.....	221	CM81301.....	223	CPCP 4125 4R.....	356	CS1534.....	339
CH2209.....	399	CM4190.....	221	CM81501.....	223	CPCP 4130 3H.....	356	CS1539.....	339
CH61800.....	399	CM4191.....	221	CMM2247.....	224	CPCP 4130 3R.....	356	CS1572.....	339
CL337.....	261	CM458544.....	223	CMM2248.....	224	CPCP 4130 4H.....	356	CS170L.....	325
CL350-S.....	262	CM458722.....	223	CMM646P.....	222	CPCP 4130 4R.....	356	CS170M.....	325
CL35-250.....	261	CM458725.....	223	CMM647P.....	222	CPCP 4132 3H.....	356	CS170XL.....	325
CL35-300.....	261	CM458728.....	223	CMM648P.....	222	CPCP 4132 3R.....	356	CS175L.....	325
CL410.....	261	CM458729.....	223	CMM649P.....	222	CPCP 4132 4H.....	356	CS175M.....	325
CL420.....	261	CM458730.....	223	CMM650P.....	222	CPCP 4132 4R.....	356	CS175XL.....	325
CL422.....	261	CM458732.....	223	CMM651P.....	222	CPCP 4.....	357	CS178234.....	340
CL426.....	261	CM458733.....	223	CMM652P.....	222	CPCP 4608 D.....	354	CS190L.....	325
CL430.....	261	CM458735.....	223	CMM653P.....	222	CPCP 4608 P.....	354	CS190M.....	325
CL432.....	261	CM48304.....	221	CMM654P.....	222	CPCP 4611 D.....	354	CS190XL.....	325
CL435.....	261	CM48305.....	221	CNCSM10.....	256	CPCP 4611 P.....	354	CS21110.....	344
CL440.....	261	CM48360.....	222	CNCSM10e.....	256	CPCP 6.....	354	CS21452.....	341
CL442.....	261	CM48363.....	222	CNCSM10s.....	256	CPCP 66.....	354	CS308.....	338
CL460.....	261	CM48364.....	222	CNCSM12.....	256	CPCP 7111.....	350	CS313.....	337
CL480.....	261	CM48365.....	222	CNCSM12e.....	256	CPCP716.....	350	CS361.....	337
CL526.....	262	CM48366.....	222	COL01487-00-02.....	433	CPCP828H.....	351	CS369.....	337
CL528.....	262	CM48367.....	222	COL01488-00-02.....	433	CPCP9113.....	351	CS4122.....	342
CL6WCB-6.....	262	CM48406.....	221	COL01489-00-02.....	433	CPCP9123.....	351	CS418.....	343
CL804.....	262	CM48769.....	221	COL01918-00-08.....	434	CPCP9160.....	351	CS439.....	343
CL806W.....	262	CM48810.....	222	COL01919-00-08.....	434	CPCP9311.....	350	CS465.....	343
CL808W.....	262	CM48811.....	222	COL01970-3R-02.....	434	CPCP9315.....	350	CS5000L.....	343
CL810W.....	262	CM48949.....	221	COL01980.....	434	CPCP9356.....	351	CS5000M.....	343
CL812W.....	262	CM48979.....	221	COL02408-88-04.....	434	CPCP9356/NS.....	351	CS5000XL.....	343
CL815.....	262	CM5310.....	219	COL02409-88-04.....	434	CPCP9429.....	350	CS5121.....	343
CL818.....	262	CM5311.....	219	COL02587-88-02.....	434	CPCP9430.....	350	CS5124.....	343
CL8WCB-8.....	262	CM5312.....	219	COL02588-00-02.....	434	CPCP9538.....	351	CS5124M.....	343
CM0210.....	218	CM5313.....	219	COL02589-00-02.....	434	CPCP9789.....	350	CS51452.....	341
CM0214.....	218	CM5315.....	219	COL02688-88-02.....	434	CPCP9790.....	350	CS51609.....	341
CM0215.....	218	CM5316.....	219	COL02689-88-02.....	434	CPCP 9A.....	355	CS51714.....	341
CM0216.....	218	CM5317.....	219	COL02800-00-01.....	435	CPCP 9AC.....	355	CS526.....	340
CM10002.....	224	CM5318.....	219	COL02816-88-02.....	435	CPCP 9F.....	355	CS5508.....	340
CM10002.....	371	CM5320.....	219	COL02834-88-02.....	435	CPCPS 375.....	346	CS5605.....	341
CM10012.....	224	CM5321.....	219	COL03482-00-22.....	433	CPRED HAWK.....	355	CS5609.....	341
CM10012.....	371	CM5328.....	219	COL03489-00-02.....	433	CPRP7763.....	350	CS6714.....	342
CM10022.....	224	CM5329.....	219	COL04187-88-02.....	434	CPRP872.....	351	CS767.....	343
CM10022.....	371	CM5330.....	219	COL04188-88-02.....	434	CPRP875.....	351	CSE4521.....	343
CM10032.....	224	CM5331.....	219	COL04189-88-02.....	434	CPRP9106.....	351	CSG340.....	337
CM10032.....	371	CM5332.....	219	COL05427-88-03.....	429	CPRP9122BR.....	351	CSG361.....	338
CM10042.....	224	CM5333.....	219	COL05932-00-57.....	429	CPRP9540B.....	350	CS1823X.....	340
CM10042.....	371	CM558322.....	223	COL07200-20-00.....	429	CPRP9560.....	350	CSK500.....	340
CM10052.....	224	CM558325.....	223	COL07500-00-00.....	429	CPRP9881.....	351	CSM125L.....	325
CM10052.....	371	CM558328.....	223	COL07548-88-02.....	429	CRC03005.....	590	CSM125M.....	325
CM10062.....	224	CM558329.....	223	COL07549-88-02.....	429	CRC03060.....	589	CSM125XL.....	325
CM10062.....	371	CM558330.....	223	COL07605-88-00.....	429	CRC03095.....	589	CSR1072X.....	328
CM10072.....	224	CM558332.....	223	COL07625.....	429	CRC03130.....	589	CSR107L.....	328
CM10072.....	371	CM558333.....	223	COL09019-88-02.....	435	CS10.....	67	CSR107X.....	328
CM10082.....	224	CM558335.....	223	COL09020-88-02.....	435	CS110USA.....	343	CSR1112X.....	327
CM10082.....	371	CM558544.....	223	COL09021-88-02.....	435	CS1117.....	342	CSR111L.....	327
CM12220.....	371	CM5624.....	220	COL09022-88-02.....	435	CS1118.....	342	CSR111X.....	327
CM2202.....	220	CM62273.....	223	COL09906-88-03.....	435	CS1119.....	342	CSR23010.....	328
CM2204.....	220	CM62373.....	223	CP-7750.....	350	CS1135.....	338	CSR23011.....	328
CM2206.....	220	CM658318.....	223	CP-9361-1.....	351	CS1136.....	338	CSR23012.....	328
CM2207.....	220	CM658319.....	223	CPCP0951.....	351	CS1137.....	338	CSV236.....	337
CM2208.....	220	CM658320.....	223	CPCP0952.....	351	CS1139.....	338	CSV6355.....	337
CM2209.....	220	CM658321.....	223	CPCP 112.....	352	CS1140.....	342	CSW04.....	344
CM2210.....	220	CM658322.....	223	CPCP 112 EX.....	352	CS1141.....	338	CSW06.....	344
CM2212.....	220	CM658338.....	223	CPCP 112 S.....	352	CS1148.....	342	CSW08.....	344
CM2213.....	220	CM658339.....	223	CPCP 1210.....	352	CS1164.....	339	CSW10.....	344
CM2214.....	220	CM658340.....	223	CPCP 1210S.....	352	CS1165M.....	339	CSW12.....	344
CM2215.....	220	CM658341.....	223	CPCP 1210 SVR.....	352	CS125L.....	324	CSWS02.....	344
CM2216.....	220	CM658342.....	223	CPCP 12 2B.....	356	CS125M.....	324	CT12036.....	186
CM2217.....	220	CM659222.....	223	CPCP 12 2H.....	356	CS125XL.....	324	CT812.....	186
CM2218.....	220	CM659225.....	223	CPCP 1230 S.....	353	CS135L.....	324	CT818.....	186

Spokane, WA 509-535-9841

Billings, MT 406-248-7196

Yakima, WA 509-248-1144

Gillette, WY 307-682-8522



CT951TR.....	186	DI1202794.....	299	DP11156.....	381	DP5800633.....	374	DTDCD920KX.....	27
CXAHD10X10.....	606	DI1202821.....	299	DP11162.....	381	DP5800636.....	374	DTDCD940KX.....	17
CXAHD12X12.....	606	DI1202844.....	299	DP11242.....	379	DP5800637.....	374	DTDCD950KX.....	17
CXAHD14X14.....	606	DI1202879.....	299	DP11268.....	379	DP70360.....	382	DTDCD960KL.....	17
CXAHD16X16.....	606	DI1202900.....	299	DP11344.....	379	DP70387.....	382	DTDCD970KL.....	17
CXAHD18X18.....	606	DI1220256.....	297	DP11352.....	379	DP70391.....	382	DTDCD980L2.....	23
CXAHD24X24.....	606	DI1220416.....	297	DP11666.....	379	DP77383.....	382	DTDCD985L2.....	23
CXAHD8X8.....	606	DI1221206.....	297	DP11709.....	379	DP77502.....	382	DTDCF610S2.....	25
CXTRH30X36.....	606	DI1221460.....	297	DP11711.....	379	DP77542.....	382	DTDCF813S2.....	25
CXTRH36X36.....	606	DI1221462.....	297	DP12286.....	381	DP78976.....	381	DTDCF815S2.....	25
DB1652990.....	232	DI1224311.....	296	DP12290.....	381	DP85149.....	381	DTDCF885C2.....	23
DB1653990.....	232	DI1240006.....	297	DP12292.....	381	DP96480.....	381	DTDCF885L2.....	24
DB1654990.....	232	DI1240007.....	297	DP12298.....	381	DPCC300M.....	373	DTDCH213L2.....	24
DB1655990.....	232	DI1240406.....	297	DP12319.....	381	DTB7254524.....	109	DTDCK210S2.....	26
DB1656990.....	232	DI1241106.....	297	DP12327.....	381	DTD21002.....	32	DTDCK211S2.....	26
DB1657990.....	233	DI1244306.....	296	DP12331.....	381	DTD25023K.....	33	DTDCK251X.....	21
DB1658990.....	232	DI1244406.....	296	DP12418.....	379	DTD25213K.....	33	DTDCK255X.....	21
DB1674990.....	233	DI1244409.....	296	DP12446.....	379	DTD25223K.....	33	DTDCK275L.....	21
DB1679990.....	233	DI2000112.....	300	DP12489.....	381	DTD25300DH.....	27	DTDCK450X.....	20
DB1680990.....	233	DI2000113.....	300	DP14369.....	380	DTD25301D.....	26	DTDCK455X.....	21
DB1681990.....	233	DI2000114.....	300	DP15096.....	381	DTD25313K.....	33	DTDCK475L.....	21
DB1682990.....	233	DI2101630.....	300	DP15263.....	382	DTD25323K.....	34	DTDCK490L2.....	24
DB1683990.....	233	DI2103670.....	299	DP15376.....	381	DTD25553K.....	34	DTDCK590L2.....	24
DB1688990.....	233	DI2103671.....	299	DP15379.....	381	DTD25602K.....	33	DTDCK655X.....	20
DB620990.....	235	DI2103673.....	300	DP15381.....	381	DTD25651K.....	34	DTDCK675L.....	20
DB624990.....	235	DI2103676.....	300	DP15479.....	380	DTD25712K.....	34	DTDCL510.....	26
DB626990.....	235	DI2103680.....	300	DP15509.....	380	DTD25762K.....	34	DTDCS380L1.....	24
DB627990.....	235	DI2104168.....	299	DP15525.....	380	DTD25901K.....	34	DTDCS391L1.....	24
DB628990.....	235	DI2104700.....	300	DP16410.....	382	DTD25980K.....	35	DTDCT410S1.....	25
DB650990.....	232	DI3101000.....	298	DP17834.....	382	DTD26441.....	39	DTDCT414S1.....	25
DB651990.....	232	DI3101051.....	298	DP17846.....	382	DTD26451K.....	39	DTDE17-959L.....	88
DB675990.....	234	DI3103031.....	298	DP17943.....	381	DTD279042.....	83	DTDE20-622.....	88
DB676990.....	234	DI3504430.....	298	DP19582.....	380	DTD279042F.....	83	DTDE28-206.....	88
DB678990.....	234	DI3504433.....	298	DP20066.....	380	DTD27904.....	83	DTDE35-7640.....	89
DB692990.....	234	DI3504450.....	298	DP20264.....	380	DTD279052.....	83	DTDE35-7645.....	89
DB694990.....	234	DI3590500.....	299	DP21536.....	380	DTD279052F.....	83	DTDE35-7646.....	89
DB695990.....	234	DI5000335.....	299	DP21537.....	380	DTD27905.....	83	DTDE35-7647.....	89
DB697990.....	234	DI5900051.....	298	DP21538.....	380	DTD279059.....	83	DTDE35-7648.....	89
DB698990.....	234	DI5904350.....	298	DP22049.....	380	DTD28065.....	36	DTDE35-7660.....	89
DB733980.....	234	DI5920050.....	298	DP23177.....	382	DTD28110.....	35	DTDE35-7662.....	89
DB734980.....	234	DI7600506.....	299	DP23754.....	379	DTD28114.....	35	DTDE35-7666.....	89
DB735980.....	234	DI7600510.....	299	DP23755.....	381	DTD28115.....	35	DTDE35-7670.....	89
DB738980.....	234	DI8300040.....	301	DP23775.....	380	DTD28131.....	35	DTDE36-715.....	88
DBL80000.....	243	DI8301020.....	301	DP23824.....	380	DTD28140.....	36	DTDE36-980.....	87
DBV30003.....	243	DI9000026.....	301	DP23857.....	379	DTD28144.....	36	DTDE36-L352.....	88
DBV30023.....	243	DI9501403.....	301	DP23876.....	380	DTD28402.....	35	DTDE370275X.....	88
DDBD-MAG.....	429	DI9502059.....	301	DP23877.....	380	DTD28474W.....	36	DTDE46-460.....	88
DDSB2000.....	429	DIPAD215AG.....	299	DP23878.....	380	DTD28493N.....	36	DTDE50-720.....	89
DI1002004.....	300	DL13001.....	84	DP25180.....	374	DTD28499X.....	36	DTDEP350.....	88
DI1003000.....	300	DL13151.....	84	DP25181.....	374	DTD28700.....	38	DTDEGR275.....	89
DI1003006.....	300	DL13201.....	84	DP26137.....	380	DTD28715.....	38	DTDEGR450.....	89
DI1101252.....	295	DL16003.....	84	DP26420.....	380	DTD51180.....	40	DTDW059K-2.....	18
DI1101254.....	296	DL16006.....	84	DP27319.....	380	DTDC012.....	22	DTDW073KD.....	412
DI1101643.....	296	DP00004.....	380	DP28508.....	382	DTDC212KA.....	19	DTDW079KD.....	412
DI1101654.....	296	DP00005.....	380	DP30187.....	380	DTDC212KL.....	19	DTDW130V.....	31
DI1101655.....	296	DP00006.....	380	DP4220003.....	372	DTDC330K.....	19	DTDW160.....	31
DI1101656.....	296	DP00007.....	380	DP4220050.....	372	DTDC385K.....	19	DTDW217.....	32
DI1101810.....	295	DP00008.....	380	DP4240001.....	372	DTDC490KA.....	20	DTDW222.....	31
DI1101811.....	295	DP00009.....	380	DP4240020.....	372	DTDC500.....	22	DTDW235G.....	30
DI1101812.....	295	DP00010.....	380	DP4244017.....	372	DTDC515K.....	22	DTDW236.....	31
DI1102000.....	295	DP02276.....	373	DP4244077.....	372	DTDC520KA.....	18	DTDW245.....	30
DI1102001.....	295	DP04706.....	380	DP4245055.....	372	DTDC530KA.....	19	DTDW246.....	30
DI1102008.....	295	DP04717.....	380	DP43724.....	380	DTDC545K.....	20	DTDW252.....	32
DI1102009.....	295	DP04812.....	380	DP4400005.....	379	DTDC546K.....	20	DTDW260K.....	32
DI1102010.....	295	DP04837.....	380	DP4400008.....	379	DTDC547K.....	20	DTDW268.....	32
DI1103270.....	295	DP04959.....	380	DP4400009.....	379	DTDC668KA.....	18	DTDW272.....	32
DI1103513.....	295	DP05032.....	380	DP4400011.....	379	DTDC720KA.....	17	DTDW292.....	32
DI1104730.....	296	DP05434.....	380	DP4400033.....	379	DTDC820KA.....	18	DTDW294.....	32
DI1107404.....	296	DP05520.....	380	DP4400037.....	379	DTDC825KA.....	18	DTDW297.....	33
DI1107976.....	294	DP05602.....	380	DP44071.....	373	DTDC827KL.....	18	DTDW304PK.....	27
DI1107977.....	294	DP05649.....	380	DP44490.....	381	DTDC835KA.....	27	DTDW311K.....	28
DI1107981.....	294	DP05700.....	380	DP44889.....	381	DTDC845KA.....	26	DTDW317K.....	27
DI1108500.....	294	DP05748.....	380	DP45949.....	380	DTDC9096.....	22	DTDW331K.....	28
DI1108501.....	294	DP05802.....	380	DP46851.....	373	DTDC9180.....	21	DTDW3578.....	109
DI1108502.....	294	DP05836.....	380	DP46901.....	373	DTDC9310.....	22	DTDW364.....	28
DI1108507.....	294	DP05864.....	380	DP47029.....	374	DTDC9319.....	22	DTDW368.....	28
DI1108652.....	294	DP05884.....	380	DP53729.....	381	DTDC9320.....	22	DTDW369CSK.....	28
DI1113121.....	294	DP05976.....	380	DP53735.....	381	DTDCB100.....	26	DTDW384.....	28
DI1113124.....	294	DP06012.....	380	DP53737.....	381	DTDCB101.....	25	DTDW432.....	39
DI1113127.....	294	DP07429.....	382	DP53741.....	381	DTDCB120.....	26	DTDW433.....	39
DI1113190.....	294	DP07431.....	382	DP53742.....	381	DTDCB200.....	25	DTDW443.....	38
DI1113191.....	294	DP07434.....	382	DP53743.....	381	DTDCD710S2.....	25	DTDW4947.....	36
DI1113192.....	294	DP07439.....	382	DP5800630.....	374	DTDCD760KL.....	17	DTDW505.....	30
DI1201390.....	300	DP07442.....	382	DP5800631.....	374	DTDCD780C2.....	23	DTDW5348.....	97
DI1202754.....	299	DP07450.....	382	DP5800632.....	374	DTDCD910KX.....	26	DTDW5349.....	97



Part Number Index

www.edgecs.com

DTDW5350.....	97	DTDW5731.....	100	DTDW5917.....	101	DTPC342K.....	90	EAU2-51-SY.....	244
DTDW5401.....	97	DTDW5732.....	98	DTDW5918.....	101	DTPC343K.....	90	EAU2-51-SY.....	335
DTDW5401B25.....	99	DTDW5733.....	98	DTDW5919.....	101	DTPC352VS.....	90	EAUI-10-S.....	244
DTDW5402.....	97	DTDW5734.....	98	DTDW5920.....	101	DTPC360VS.....	90	EAUI-10-S.....	335
DTDW5403.....	97	DTDW5740.....	100	DTDW5921.....	101	DTPC362V.....	90	EAUI-20-S.....	244
DTDW5403B25.....	99	DTDW5741.....	100	DTDW5922.....	101	DTPC390K.....	90	EAUI-20-S.....	335
DTDW5404.....	97	DTDW5742.....	100	DTDW5923.....	101	DTPC4216.....	91	EAUI-20-SY.....	244
DTDW5405.....	97	DTDW5746.....	100	DTDW5924.....	101	DTPC5560.....	91	EAUI-20-SY.....	335
DTDW5406.....	99	DTDW5747.....	100	DTDW5925.....	101	DTPC5561.....	91	EAUI-50-SY.....	244
DTDW5407.....	97	DTDW5748.....	100	DTDW5926.....	101	DTPC5562.....	91	EAUI-50-SY.....	335
DTDW5408.....	97	DTDW5749.....	100	DTDW5927.....	101	DTPC5563.....	91	EC43647.....	147
DTDW5410.....	97	DTDW5752.....	100	DTDW5930.....	101	DTPC557.....	91	ED9701.....	318
DTDW5412.....	97	DTDW5753.....	100	DTDW5931.....	101	DTPC690LR.....	91	ED9705.....	318
DTDW5416.....	99	DTDW5755.....	100	DTDW5932.....	101	DTPC7310.....	90	EDTSDK215.....	318
DTDW5416B25.....	99	DTDW5756.....	100	DTDW5933.....	101	DTPC7312.....	90	EDTSK215.....	318
DTDW5417.....	97	DTDW5757.....	100	DTDW5934.....	101	DTPC7518.....	91	EDTSK216.....	318
DTDW5417B25.....	99	DTDW5758.....	100	DTDW5935.....	101	DTPC895PK.....	91	EDTSK21-G15-7.....	318
DTDW5418.....	97	DTDW5759.....	100	DTDW5936.....	101	DTPC97311.....	91	EDTSKAP218.....	318
DTDW5418B25.....	99	DTDW5760.....	100	DTDW5937.....	101	DW1433.....	436	EDTSM212.....	318
DTDW5420.....	97	DTDW5761.....	100	DTDW5938.....	101	DW1447.....	436	EDTSM215.....	318
DTDW5421.....	99	DTDW5764.....	100	DTDW5939.....	101	DW1448.....	436	EDTSM216.....	318
DTDW5424.....	97	DTDW5765.....	100	DTDW5940.....	101	DW1449.....	436	EDTSM21-G15-7.....	318
DTDW5424B25.....	99	DTDW5770.....	100	DTDW5941.....	101	DW1533.....	436	EDTSMAP218.....	318
DTDW5426.....	99	DTDW5771.....	100	DTDW5942.....	101	DW1547.....	436	EDTSRG216.....	318
DTDW5427.....	97	DTDW5772.....	100	DTDW5943.....	101	DW1548.....	436	EE1190.....	415
DTDW5427B25.....	99	DTDW5773.....	99	DTDW5945.....	101	DW1549.....	436	EE120.....	415
DTDW5429.....	97	DTDW5774.....	99	DTDW5950.....	99	DW1730.....	436	EE1240.....	415
DTDW5430.....	99	DTDW5779.....	100	DTDW5951.....	99	DW1732.....	436	EE36.....	414
DTDW5431.....	97	DTDW5780.....	100	DTDW5952.....	99	DW2407.....	436	EE410-48.....	415
DTDW5432.....	99	DTDW5780B15.....	100	DTDW5953.....	99	DW2447.....	436	EE418-54.....	415
DTDW5433.....	97	DTDW5781.....	100	DTDW5954.....	99	DW2507.....	436	EE581-24.....	414
DTDW5435.....	97	DTDW5782.....	100	DTDW5958.....	99	DW2547.....	436	EE581-48.....	414
DTDW5437.....	97	DTDW5783.....	100	DTDW5960.....	101	DW2608.....	436	EE581-72.....	414
DTDW5437B25.....	99	DTDW5785.....	99	DTDW5961.....	101	DW2647.....	436	EE77-001.....	335
DTDW5438.....	97	DTDW5786B.....	100	DTDW5962.....	101	DW2648.....	436	EE77-002.....	335
DTDW5439.....	99	DTDW5803.....	98	DTDW5963.....	101	DW2708.....	436	EE77-003.....	335
DTDW5440.....	99	DTDW5804.....	101	DTDW5964.....	101	DW2709.....	436	EE77-0204.....	335
DTDW5441.....	99	DTDW5806.....	101	DTDW5965.....	101	DW2747.....	436	EE77-1001.....	335
DTDW5442.....	99	DTDW5807.....	98	DTDW5966.....	101	DW2748.....	436	EE77-1002.....	335
DTDW5443.....	99	DTDW5809.....	98	DTDW5967.....	101	DW2809.....	436	EE77-1004.....	335
DTDW5444.....	97	DTDW5810.....	98	DTDW616.....	39	DW2847.....	436	EE908BR.....	413
DTDW5446.....	99	DTDW5812.....	101	DTDW616PK.....	40	DW2848.....	436	EE912BR.....	413
DTDW5447.....	99	DTDW5813.....	98	DTDW621.....	39	DW2909.....	436	EE916BR.....	413
DTDW5448.....	99	DTDW5814.....	98	DTDW625.....	40	DW2947.....	436	EE924BR.....	413
DTDW5449.....	97	DTDW5815.....	98	DTDW660.....	38	DW2948.....	436	EEE250.....	414
DTDW5450.....	99	DTDW5816.....	101	DTDW682K.....	40	DW3000-1.....	436	EEE255.....	415
DTDW5453.....	99	DTDW5818.....	101	DTDW713.....	29	DW402.....	436	EEE80.24.....	414
DTDW5455.....	99	DTDW5819.....	98	DTDW715.....	29	DW4052.....	437	EEE80.48.....	414
DTDW5456.....	99	DTDW5820.....	98	DTDW717.....	29	DW405.....	436	EEE80.72.....	414
DTDW5457.....	97	DTDW5821.....	101	DTDW718.....	29	DW5166.....	436	EEE90.24.....	414
DTDW5460.....	99	DTDW5822.....	101	DTDW723.....	30	DW5169.....	436	EEE90.48.....	414
DTDW5461.....	99	DTDW5824.....	101	DTDW740.....	30	DW5266.....	436	EEEM71.24.....	414
DTDW5462.....	99	DTDW5825.....	101	DTDW745.....	29	DW5269.....	436	EEEM71.48.....	414
DTDW5464.....	97	DTDW5826.....	98	DTDW756.....	37	DW606.....	436	EEEM81.10.....	414
DTDW5466.....	99	DTDW5827.....	101	DTDW758.....	37	DW910.....	437	EEEM81.9.....	414
DTDW5470.....	100	DTDW5827.....	98	DTDW7737.....	109	DY15603.....	604	EMDW10X10.....	605
DTDW5700.....	100	DTDW5828.....	101	DTDW7739.....	109	DY18051.....	604	EMDW12X12.....	605
DTDW5701.....	100	DTDW5830.....	98	DTDW7745.....	109	DY18053.....	604	EMDW14X14.....	605
DTDW5702.....	100	DTDW5831.....	98	DTDW7749.....	109	DY18055.....	604	EMDW16X16.....	605
DTDW5703.....	100	DTDW5832.....	99	DTDW7880.....	30	DY18057.....	604	EMDW18X18.....	605
DTDW5704.....	100	DTDW5833.....	98	DTDW788.....	28	DY18434.....	604	EMDW24X24.....	605
DTDW5705.....	100	DTDW5834.....	98	DTDW8001.....	66	DY18439.....	604	EMDW30X30.....	605
DTDW5706.....	98	DTDW5835.....	99	DTDW8002.....	66	DY18445.....	604	EMDW36X36.....	605
DTDW5708.....	100	DTDW5835B15.....	99	DTDW8003.....	66	DY18483.....	604	EMDW48X48.....	605
DTDW5709.....	98	DTDW5837.....	98	DTDW8004.....	66	DY18484.....	604	EMDW6X6.....	605
DTDW5710.....	100	DTDW5838.....	99	DTDW831.....	35	DY18485.....	604	EMDW8X8.....	605
DTDW5711.....	98	DTDW5842.....	99	DTDW840.....	36	DY18486.....	604	EMFR12X12.....	605
DTDW5712.....	98	DTDW5843.....	99	DTDW847.....	37	DY18487.....	604	EMFR18X18.....	605
DTDW5713.....	100	DTDW5846.....	99	DTDW849.....	37	DY18488.....	604	EMFR24X24.....	605
DTDW5714.....	98	DTDW5847.....	99	DTDW8500.....	109	DY18489.....	604	EMFR36X36.....	605
DTDW5715.....	100	DTDW5848B.....	99	DTDW887.....	36	DY622289.....	604	EMFR8X8.....	605
DTDW5716.....	100	DTDW5900.....	98	DTDW888.....	37	DY622290.....	604	EMFRC12X12.....	605
DTDW5717.....	98	DTDW5901.....	98	DTDW893.....	38	EA1915.....	244	EMFRC18X18.....	605
DTDW5719.....	98	DTDW5902.....	98	DTDW896.....	38	EA1925.....	244	EMFRC24X24.....	605
DTDW5720.....	98	DTDW5903.....	98	DTDW906.....	27	EA1932.....	244	EMFRC8X8.....	605
DTDW5721.....	98	DTDW5904.....	98	DTDW919.....	21	EA1947.....	244	EMRAH24X24.....	605
DTDW5722.....	98	DTDW5905.....	98	DTDW941K-2.....	27	EA1962.....	244	EMRAH30X36.....	605
DTDW5723.....	98	DTDW5906.....	98	DTDW960K-2.....	19	EA1962.....	244	EMRAH36X36.....	605
DTDW5724.....	98	DTDW5907.....	98	DTDWD112.....	31	EA1962.....	244	EMRAH48X48.....	605
DTDW5725.....	98	DTDW5909.....	98	DTDWD115K.....	31	EAFD-25.....	244	ENA-66.....	227
DTDW5726.....	98	DTDW5910.....	98	DTDWD215G.....	30	EAFD-25.....	335	ENC-604.....	225
DTDW5727.....	100	DTDW5911.....	98	DTDWD460.....	31	EAU2-26-S.....	244	ENCH-604.....	225
DTDW5728.....	98	DTDW5914.....	101	DTDWDM120K.....	37	EAU2-26-S.....	335	ENCR-400.....	225
DTDW5729.....	98	DTDW5915.....	101	DTDWS520SK.....	30	EAU2-51-S.....	244	ENHF-100.....	226
DTDW5730.....	98	DTDW5916.....	101	DTDWS535.....	27	EAU2-51-S.....	335	ENHF-101.....	226

Spokane, WA 509-535-9841

Billings, MT 406-248-7196

Yakima, WA 509-248-1144

Gillette, WY 307-682-8522



ENHF-102.....	226	ET25549.....	601	GO12-15 RMA.....	232	GR36402.....	168	GR62PTS-3/4.....	168
ENMSFP-5.....	226	ET300110.....	602	GO12-15 RMO.....	232	GR36414.....	168	GR62PTS-5/8.....	168
ENP-391.....	227	ET45008P-0030.....	601	GR00042.....	162	GR36489.....	162	GR62PTS-7/8.....	168
ENP-392.....	227	ET55008PQ.....	602	GR06923.....	170	GR36490.....	162	GR635.....	170
ENP-462.....	226	ETS51323.....	602	GR0952-01.....	184	GR36587.....	184	GR643.....	175
ENP-80.....	227	EZ40-PO-SET.....	237	GR10443.....	174	GR37218.....	183	GR647.....	184
ENRC-1006.....	226	EZ50-PO-SET.....	237	GR10565.....	173	GR37279.....	171	GR654.....	177
ENRC-101.....	226	EZ60-PO-SET.....	237	GR111952.....	361	GR37868.....	169	GR657.....	184
ENRC-1014.....	226	EZ60-PO-SET-SB.....	237	GR111952.....	362	GR37869.....	169	GR658.....	177
ENRC-102.....	226	EZ66-PO-SET.....	237	GR111964K.....	362	GR38068.....	169	GR659.....	177
ENRC-104.....	226	FLOOR SWEEP.....	615	GR12085.....	165	GR38083.....	169	GR668.....	183
ENRC-106.....	226	FLOOR SWEEP/WAX.....	615	GR12086.....	165	GR38088.....	169	GR66PT-11/16.....	169
ENRC-151.....	226	FN6-35-02-105-01-2.....	71	GR12087.....	165	GR38103.....	168	GR66PT-1[1/4].....	169
ENRC-156.....	226	FN6-35-02-106-01-5.....	71	GR12097.....	163	GR38113.....	169	GR66PT-1.....	169
ENRC-2510.....	226	FN6-35-02-118-01-6.....	72	GR12099.....	163	GR38118.....	169	GR66PT-1[1/8].....	169
ENRC-251.....	226	FN6-35-02-126-01-3.....	71	GR124AV.....	163	GR38119.....	169	GR66PT-1/2.....	169
ENRC-256.....	226	FN6-35-02-144-01-4.....	72	GR126AV.....	163	GR38133.....	169	GR66PT-13/16.....	169
ENRC-5013.....	226	FN6-35-02-151-01-8.....	71	GR1429AV.....	164	GR38568.....	363	GR66PT-15/16.....	169
ENRC-51.....	226	FN6-37-17-082-03-3.....	73	GR1430AV.....	164	GR38693.....	169	GR66PT-3/4.....	169
ENRR-506.....	227	FN6-37-17-082-04-9.....	72	GR1431AV.....	164	GR38733.....	183	GR66PT-5/8.....	169
ENRSM-300.....	226	FN6-37-17-083-04-3.....	72	GR1432AV.....	164	GR390.....	175	GR66PT-7/8.....	169
ENRSM-500.....	226	FN6-37-17-085-04-5.....	72	GR15908.....	163	GR4016GB.....	184	GR678.....	177
ENRSM-50.....	226	FN6-37-17-088-04-0.....	72	GR1614SS.....	165	GR4017GB.....	184	GR6805A.....	176
ENWR-5.....	227	FN6-37-17-090-04-6.....	72	GR1675AV.....	163	GR405.....	177	GR6810.....	175
ERBSTFG1000.....	194	FN6-37-17-108-04-7.....	72	GR1725.....	165	GR411-3-1/2.....	176	GR683.....	184
ERBSTFG1000.....	611	FN6-37-17-109-04-1.....	72	GR17944.....	172	GR430.....	174	GR684.....	184
ERBSTFO1000.....	194	FN6-37-17-110-04-3.....	72	GR17979.....	172	GR431.....	174	GR687.....	184
ERBSTFO1000.....	611	FN6-37-17-111-04-2.....	72	GR17986.....	172	GR43177.....	363	GR690.....	174
ERBSTFP1000.....	194	FN6-37-17-112-04-5.....	72	GR1800.....	171	GR43178.....	363	GR704.....	180
ERBSTFP1000.....	611	FN6-37-17-115-04-1.....	72	GR1801.....	171	GR434.....	177	GR706.....	180
ERBSTFY1000.....	194	FN6-37-17-116-04-4.....	72	GR1802.....	172	GR435.....	177	GR709.....	166
ERBSTFY1000.....	611	FN6-37-17-227-01-0.....	72	GR1803065.....	361	GR439-1.....	174	GR710.....	166
ERCDB160600.....	194	FN6-37-17-227-02-0.....	72	GR1803066.....	361	GR440AV.....	163	GR713.....	166
ERCDB160600.....	611	FN6-37-17-228-02-0.....	72	GR1810.....	170	GR441-2.....	176	GR718.....	179
ERCDB240600.....	194	FN6-37-17-229-01-0.....	72	GR1811.....	170	GR441-3.....	176	GR720.....	166
ERCDB240600.....	611	FN6-37-17-230-02-0.....	72	GR1813.....	172	GR441-4.....	176	GR721-1-1/2.....	162
ERCDB280600.....	194	FN6-37-17-231-02-0.....	72	GR1818.....	171	GR442AV.....	163	GR721-1-1/4.....	162
ERCDB280600.....	611	FN6-37-17-232-01-0.....	72	GR1895.....	173	GR445.....	176	GR721-1.....	162
ERPCMT3000.....	194	FN6-37-31-001-01-4.....	72	GR1900.....	181	GR45206.....	180	GR721-1/2.....	162
ERPCMT3000.....	611	FN6-37-31-002-01-7.....	72	GR1905.....	181	GR45207.....	180	GR7211BB-1-1/2.....	162
ERTWM160600.....	194	FN6-38-06-129-02-6.....	73	GR1916.....	161	GR48330.....	362	GR7211BB-1-1/4.....	162
ERTWM160600.....	611	FN6-38-06-136-02-9.....	73	GR1918.....	161	GR501.....	182	GR7211BB-1.....	162
ERTWM200600.....	194	FN6-38-06-183-01-3.....	73	GR1924AA.....	161	GR504.....	178	GR7211BB-1/2.....	162
ERTWM200600.....	611	FN6-38-06-195-02-0.....	73	GR1925AA.....	161	GR5060 MESH.....	182	GR7211BB-2.....	162
ERTWPY080600.....	611	FN6-39-01-025-06-0.....	73	GR1926AA.....	161	GR508.....	170	GR7211BB-3/4.....	162
ERTWPY081200.....	611	FN6-39-03-165-01-3.....	72	GR1941-1.....	184	GR512.....	170	GR721-2.....	162
ERTWPY120600.....	611	FN6-39-03-167-40-2.....	73	GR20495.....	163	GR516.....	170	GR721-3/4.....	162
ERTWPY121200.....	611	FN6-39-03-167-41-1.....	73	GR2113AA.....	164	GR540-12.....	174	GR7235BB.....	165
ERTWPY160600.....	611	FN6-39-03-178-01-7.....	72	GR22292.....	180	GR540-24.....	174	GR7237BB.....	165
ERTWPY200600.....	611	FN6-39-03-205-01-5.....	71	GR23802.....	172	GR54923.....	361	GR7238SB.....	163
ERTWPY240600.....	611	FN9-20-24.....	84	GR249AVBB.....	163	GR54924.....	361	GR724.....	166
ERWP12503000.....	194	FN9-20-25.....	84	GR28007.....	172	GR555C.....	171	GR727.....	179
ERWP12503000.....	611	FN9-20-26.....	84	GR28154.....	162	GR555CX.....	171	GR7310.....	165
ERWP18003000.....	194	FNFM250QSELECT.....	71	GR28155.....	162	GR555DX.....	172	GR7310SB.....	165
ERWP18003000.....	611	FNFM250START.....	71	GR28156.....	162	GR591.....	175	GR7506.....	161
ERWP25003000.....	194	GB960H.....	185	GR28157.....	162	GR595.....	174	GR755.....	166
ERWP25003000.....	611	GB961H.....	185	GR28158.....	162	GR597.....	178	GR756.....	179
ES3000037EG.....	468	GB962H.....	185	GR28159.....	162	GR599.....	178	GR759.....	180
ES3000037PL.....	468	GBB2000.....	185	GR28160.....	162	GR60237.....	163	GR7646.....	165
ES3000050EG.....	468	GBCP8000.....	185	GR28161.....	162	GR60242.....	166	GR767.....	163
ES3000050PL.....	468	GBFTS125R.....	185	GR28162.....	162	GR60246.....	163	GR7706SB.....	164
ES3000062PL.....	468	GBFTS250.....	185	GR28163.....	162	GR604.....	174	GR774.....	179
ES3050037S4.....	467	GBFTS65R.....	185	GR28165.....	162	GR607.....	174	GR7806SB.....	164
ES3050050S4.....	467	GBHS-8524.....	185	GR28166.....	162	GR608.....	176	GR7904SB.....	164
ES3100037EG.....	468	GBKOH540A.....	185	GR29451.....	161	GR609.....	175	GR7906SB.....	164
ES3100037PL.....	468	GBKOW520.....	185	GR29452.....	161	GR610.....	175	GR796.....	181
ES3100050EG.....	468	GJ0915-06.....	590	GR2981AV.....	164	GR611.....	175	GR8012.....	176
ES3100050PL.....	468	GJ0950-24.....	590	GR2982AV.....	164	GR612.....	175	GR8018.....	176
ESFNFMM250QTOP.....	71	GJ0955-04.....	590	GR2983AV.....	164	GR613.....	175	GR8024.....	176
ET107507-0100.....	600	GJ9652-12.....	334	GR2984AV.....	164	GR614.....	175	GR840A.....	170
ET12060.....	600	GNAWP-25SAC.....	214	GR30008.....	168	GR615.....	175	GR841A.....	170
ET145202.....	601	GNAWP-30SAC.....	214	GR301.....	169	GR616.....	175	GR842A.....	170
ET145236.....	601	GNGH3.8.....	217	GR3026AV.....	163	GR616/62PTS-1[1/4].....	168	GR843A.....	170
ET203202.....	600	GNGH5.6.....	217	GR3026AV.....	165	GR61/62PTS-1-1/8.....	168	GR848.....	173
ET203203.....	600	GNGL-4.....	216	GR304AVBB.....	162	GR617.....	175	GR849.....	173
ET203208.....	600	GNGL-8.....	216	GR30578.....	178	GR618.....	175	GR851.....	173
ET203209.....	600	GNGS-1530.....	216	GR30758.....	178	GR619.....	175	GR855GX.....	170
ET20602-1024.....	600	GNGS-1930.....	216	GR31872.....	165	GR621.....	175	GR859-4.....	173
ET25004.....	601	GNGS-2646.....	215	GR333A.....	161	GR622.....	175	GR860-1[1/2].....	173
ET25006.....	601	GNSLA-10.....	215	GR33967.....	165	GR623.....	175	GR860-3.....	173
ET25008.....	601	GNSLA-15.....	215	GR34401.....	168	GR624.....	178	GR860-4.....	173
ET25542.....	601	GNSLA-5.....	215	GR34403.....	168	GR629.....	178	GR864.....	161
ET25544.....	601	GNSLC-12.....	214	GR34411.....	168	GR62PTS-11/16.....	168	GR881CT.....	172
ET25546.....	601	GNSLC-18.....	214	GR34941.....	165	GR62PTS-1.....	168	GR906.....	183
ET25548.....	601	GNSLC-24.....	214	GR35884.....	168	GR62PTS-13/16.....	168	GR909.....	183



Part Number Index

www.edgecs.com

GR910.....	183	GU0237.....	311	HG12128.....	82	HG14302.....	119	HH74008XL.....	329
GR911.....	183	GU0238.....	311	HG12130.....	82	HG14303.....	119	HH74008XS.....	329
GR9502.....	183	GU02475.....	207	HG12132.....	82	HG14304.....	119	HH75090-560.....	329
GR9525F.....	184	GU02475.....	311	HG12134.....	82	HG14322.....	119	HH75490-560.....	329
GR980.....	184	GU04625.....	310	HG12136.....	82	HG14324.....	119	HH79892-560.....	329
GR980-950.....	182	GU04628.....	310	HG12138.....	82	HG14326.....	119	HIHTJ-10.....	229
GRCRM-1.....	177	GU04630.....	310	HG12140.....	82	HG14328.....	119	HIKRS-15-SLD.....	229
GRCRM-5.....	177	GU10717.....	310	HG12142.....	82	HG14330.....	119	HIKRS-30-SLD.....	229
GRCRM-Q.....	177	GU10726.....	309	HG12144.....	82	HG14332.....	119	HIKRS-40-SLD.....	229
GRCS-8000.....	182	GU10800.....	311	HG12146.....	82	HG14334.....	119	HIKRS-60-SLD.....	229
GRDBITKIT.....	169	GU10900.....	309	HG12148.....	82	HG14336.....	119	HIKRS-8-4S.....	229
GRDM-40.....	182	GU10916.....	309	HG12150.....	82	HG14338.....	119	HL1010924.....	319
GRDM-510A.....	181	GU10917.....	309	HG12152.....	82	HG14340.....	119	HL1010970.....	319
GRDTAP10-24.....	166	GU10925.....	309	HG12154.....	82	HG14342.....	119	HL1011603.....	319
GRDTAP10-32.....	166	GU10927.....	309	HG12156.....	82	HG14344.....	119	HL1011997.....	319
GRDTAP1/4-20.....	166	GU10974.....	310	HG12158.....	82	HG14348.....	119	HLDPAS-1.....	318
GRDTAP3/8-16.....	166	GU10985.....	309	HG12160.....	82	HG14352.....	119	HLDPAS-30R.....	318
GRDTAP5/16-18.....	166	GU10987.....	309	HG12162.....	82	HG14356.....	119	HLLPF-1.....	319
GRDTAP6-32.....	166	GU10989.....	309	HG12164.....	82	HG14362.....	119	HLLPF-30.....	319
GRDTAP8-32.....	166	GU11170.....	308	HG12214.....	82	HG14366.....	119	HLMAX-1.....	319
GRDTAPKIT.....	166	GU11171.....	308	HG12216.....	82	HG14368.....	119	HLMAX-30.....	319
GRECCX11.....	178	GU11172.....	308	HG12218.....	82	HG14372.....	119	HLMM-1.....	318
GREK124011.....	180	GU11173.....	308	HG12220.....	82	HG14374.....	119	HLQB100HYG.....	319
GRESG50GL11.....	179	GU15030.....	310	HG12222.....	82	HG14378.....	119	HLQB1HYG.....	319
GRF020196K.....	361	GW80057.....	264	HG12224.....	82	HG14380.....	119	HLQB200HYG.....	319
GRF020197K.....	361	GW80325.....	245	HG12226.....	82	HG14384.....	119	HLQB2HYG.....	319
GRF20.....	363	GW80556.....	246	HG12228.....	82	HG24131.....	83	HLQB300HYG.....	319
GRFIBR-1.....	177	GW80557.....	246	HG12230.....	82	HG3-12224.....	82	HLQB3HYG.....	319
GRFIBR-Q.....	177	GW80707.....	247	HG12232.....	82	HG3-12226.....	82	HLQD1.....	319
GRFTN536-100.....	173	GW80715.....	247	HG12234.....	82	HG3-12228.....	82	HLQD30.....	319
GRFTS438-125.....	174	GW80880.....	248	HG12236.....	82	HG3-12230.....	82	HLQM24+.....	320
GRFTS438-240.....	174	GW81918.....	257	HG12238.....	82	HG3-12232.....	82	HP-P002.0.....	160
GRFTS438-65.....	174	GW82210.....	280	HG12240.....	82	HG3-12234.....	82	HP-P002.0.....	387
GRFTS438W-100.....	174	GW82216.....	280	HG12242.....	82	HG3-12236.....	82	HP-P002.5.....	160
GRGRDTAP12-24.....	166	GW82220.....	280	HG12244.....	82	HG3-12238.....	82	HP-P002.5.....	387
GRGT-12.....	181	GW82248.....	280	HG12246.....	82	HG3-12240.....	82	HP-P003.0.....	160
GRH4665A.....	363	GW82304.....	259	HG12248.....	82	HG3-12242.....	82	HP-P003.0.....	387
GRH4802-1.....	362	GW82305.....	259	HG12250.....	82	HG3-12244.....	82	HP-P003.5.....	160
GRH4802-3.....	362	GW9008.....	258	HG12252.....	82	HG3-12246.....	82	HP-P003.5.....	387
GRH4802.....	362	GW9010.....	258	HG12254.....	82	HG3-12248.....	82	HP-P004.0.....	160
GRH4802-5.....	362	GW9011.....	258	HG12256.....	82	HG3-12250.....	82	HP-P004.0.....	387
GRH4802-6.....	362	GW9012.....	258	HG12258.....	82	HG3-12252.....	82	HP-P004.5.....	160
GRH4905A.....	362	GW9014.....	258	HG12260.....	82	HG3-12254.....	82	HP-P004.5.....	387
GRH4910A.....	362	GW9016.....	258	HG12262.....	82	HG3-12256.....	82	HP-P005.0.....	160
GRH6400C.....	363	GW9018.....	258	HG12264.....	82	HG3-12258.....	82	HP-P005.0.....	387
GRH6510A.....	362	GW9020.....	258	HG12266.....	82	HG3-12260.....	82	HP-P005.5.....	160
GRH8508-1.....	362	GW9022.....	258	HG12268.....	82	HG3-12262.....	82	HP-P005.5.....	387
GRH8508-1V.....	362	GW9024.....	258	HG12270.....	82	HG3-12264.....	82	HP-P006.0.....	160
GRH8508-3.....	362	GW9026.....	258	HG12272.....	82	HG3-12266.....	82	HP-P006.0.....	387
GRH8508-3V.....	362	GW9028.....	258	HG12274.....	82	HG3-12268.....	82	HP-P007.0.....	160
GRHCS8160CB.....	363	GW9030.....	258	HG12276.....	82	HG3-12270.....	82	HP-P007.0.....	387
GRHCS816.....	363	GW9032.....	258	HG13007C.....	119	HG3-12272.....	82	HP-P008.0.....	160
GRHCS820.....	363	GW9034.....	258	HG14005C.....	125	HG3-12274.....	82	HP-P008.0.....	387
GRHFC30.....	364	GW9036.....	258	HG14009.....	119	HG3-12276.....	82	HP-P009.0.....	160
GRHK520.....	179	GW9038.....	258	HG14222.....	119	HG75005.....	81	HP-P009.0.....	387
GRHPB45-1AVS.....	364	GW9040.....	258	HG14224.....	119	HGHMD115.....	80	HP-PS.....	160
GRHPB45-2AVS.....	364	GW9042.....	258	HG14226.....	119	HGHMD150.....	80	HS125FAV.....	368
GRHPB55-1AVS.....	364	GW9044.....	258	HG14228.....	119	HGHMD505.....	81	HS125KT.....	369
GRHPD-HV-U.....	361	GW9046.....	258	HG14230.....	119	HGHMD904C.....	81	HS170FAVT.....	369
GRHPD-T-U.....	361	GW9048.....	258	HG14232.....	119	HGHMD914.....	81	HS175KT.....	369
GRK09-2SPGL.....	181	GW9050.....	258	HG14234.....	119	HGHMD915.....	81	HS200CV.....	369
GRL77.....	161	GW9052.....	258	HG14236.....	119	HGHMD925.....	81	HS200CV.....	616
GRL97.....	161	GW9054.....	258	HG14238.....	119	HH70260-260.....	329	HS210KT.....	369
GRLRF75.....	363	GW9056.....	258	HG14240.....	119	HH70260-360.....	329	HS400FAVT.....	369
GRLRF88.....	363	GW9060.....	258	HG14242.....	119	HH703002XL.....	330	HS80CV.....	369
GRR496.....	361	GW9062.....	258	HG14244.....	119	HH703003XL.....	330	HS80CV.....	616
GRRS438-125.....	174	GW9317.....	256	HG14246.....	119	HH703004XL.....	330	HS85FAV.....	368
GRRS438-240.....	174	GW9533.....	256	HG14248.....	119	HH70300L.....	330	ICEMELT.....	619
GRRS438-65.....	174	GW9700.....	256	HG14250.....	119	HH70300M.....	330	ID35-078.....	122
GRS2613.....	175	HFPXXXX.....	491	HG14252.....	119	HH70300S.....	330	IG9346.....	333
GRSA54.....	361	HFSWXXXX.....	491	HG14254.....	119	HH70300XL.....	330	IG9346.....	620
GRUA.....	361	HG10527.....	83	HG14256.....	119	HH70300XS.....	330	IGGT1610.....	332
GRUG511T.....	177	HG10528.....	83	HG14260.....	119	HH70333-260FL.....	328	IGGT1610.....	620
GRUT-2.....	176	HG10531.....	83	HG14262.....	119	HH70333-360FL.....	328	IGGT1640.....	332
GRUT-4.....	176	HG10532.....	83	HG14264.....	119	HH70444-260FL.....	328	IGGT1640.....	620
GU00101.....	311	HG10533.....	83	HG14266.....	119	HH70444-360FL.....	328	IGGT1683.....	332
GU00235.....	310	HG10534.....	83	HG14268.....	119	HH72190-960.....	329	IGGT1683.....	620
GU00250.....	310	HG10731.....	81	HG14272.....	119	HH72191-960.....	329	IGGT1685.....	332
GU00300.....	311	HG12114.....	82	HG14274.....	119	HH72490-960.....	329	IGGT1685.....	620
GU00320.....	311	HG12116.....	82	HG14276.....	119	HH740082XL.....	329	IGGT8257UN.....	333
GU00340.....	311	HG12118.....	82	HG14278.....	119	HH740083XL.....	329	IGGT8257UN.....	620
GU00645.....	311	HG12120.....	82	HG14280.....	119	HH740084XL.....	329	IR15001-SH.....	425
GU00656.....	311	HG12122.....	82	HG14282.....	119	HH74008L.....	329	IR15001-SH.....	604
GU00815.....	310	HG12124.....	82	HG14284.....	119	HH74008M.....	329	IR15002-SH.....	425
GU01231.....	309	HG12126.....	82	HG14301.....	119	HH74008S.....	329	IR15002-SH.....	604

Spokane, WA 509-535-9841

Billings, MT 406-248-7196



IR2031314DS	423	IT1-1/4	398	JS3001941	314	KC44325	330	KL5104	201
IR2073111	265	IT118TUNDRA	398	JS3004019	330	KC44326	330	KL5106	202
IR2073112	265	IT12	398	JS3004042	330	KC91371	590	KL5109	202
IR2073113	265	IT1	398	JS3004158	330	KE1020	76	KL5109PS	202
IR2073211	265	IT14	398	JS3004205	330	KE157-24	76	KL5118C	202
IR2073212	265	IT2	398	JS3004880	315	KE157-26	76	KL5144	202
IR2082101	270	IT34	398	JS3004882	315	KE157-54	76	KL5172PS	202
IR2082200	271	IT38	398	JS3005052	316	KE157-56	76	KL5416	202
IR2084100	271	IT58	398	JS3005334	314	KE157-58	76	KL5416T	202
IR2084300	271	IT78TUNDRA	398	JS3005346	314	KE40-20	76	KL5417T	202
IR2084400	271	JB1210	534	JS3005371	316	KE40-21	76	KL5459T	202
IR233250	424	JB1210HDG	534	JS3005378	316	KE42-20	76	KL5471	202
IR233250	603	JB1212	534	JS3005379	316	KE60-20	76	KL600-1	200
IR24021	110	JB126	534	JS3005399	316	KE60-21	76	KL600-12	200
IR24030	110	JB128	534	JS3005543	396	KE60-22L	76	KL600-4	200
IR30103-SH	425	JB3410	534	JS3005545	396	KE60-22R	76	KL600-6	200
IR30103-SH	604	JB3412	534	JS3005547	396	KE95-20	76	KL600-8	200
IR3041001	117	JB5810	534	JS3006007	331	KEK-200	75	KL601-10	199
IR3041002	117	JB5810HDG	534	JS3006273	326	KEKD-442	76	KL601-3	199
IR3041003	117	JB5812	534	JS3006598	331	KEKD-493	76	KL601-4	199
IR3041004	117	JB5812HDG	534	JS3006634	331	KEKIT#100	75	KL601-6	199
IR3041005	117	JB588	534	JS3006648	331	KEKIT#101	77	KL601-8	199
IR3041006	117	JE11127	283	JS3006693	331	KEKIT#102	76	KL602-3	200
IR3041007	117	JE11128	283	JS3007305	399	KEKIT#106	76	KL602-4	200
IR3041009	117	JE21400	283	JS3007354	331	KEKIT#210	75	KL602-6	200
IR3057014	117	JE21500	283	JS3007594	399	KEKIT#340	75	KL602-8	200
IR35010-SH	424	JE22005	284	JS3007641	331	KEKIT#342	75	KL602-10	200
IR35010-SH	604	JE22006	284	JS3007642	331	KEKS-226	75	KL603-1	200
IR39004	117	JE63200	283	JS3007914	331	KEP-500	75	KL603-3	200
IR39005	117	JE63201	283	JS3007915	331	KI292474	336	KL603-4	200
IR39006	117	JEHBS-916W	79	JS3007917	331	KI366242	336	KL603-6	200
IR39007	117	JEHVBS-7MW	79	JS3007973	331	KI466112K	336	KL603-7	200
IR39008	117	JEJBJ-12-1/2L	230	JS3011375	315	KI466204K	336	KL605-4	199
IR39108-SH	425	JEJPD-20MF	79	JS3011712	315	KI466206K	336	KL605-6	199
IR39108-SH	604	JEPT-2748W	230	JS3011713	315	KI466227-01	336	KL605-8	199
IR39404	117	JMES	388	JS3011717	315	KI466227K	336	KL627-20	203
IR39405	117	JMHD	388	JS3011718	315	KI466400	336	KL628-20	203
IR39406	117	JMHS-1	388	JS3011719	315	KI466401	336	KL630-11/32	201
IR39408	117	JMHS-2	388	JS3011839	397	KL1001	198	KL630-1/2	201
IR39608	117	JMHS-3	388	JS3012943	326	KL1005	198	KL630-1/4	201
IR64110	422	JMLM	388	JS3012944	326	KL1006	198	KL630-3/16	201
IR64494	423	JMPS-1	388	JS3012945	326	KL1010	198	KL630-3/8	201
IR64495	423	JMPS-2	388	JS3012947	326	KL1011	197	KL63050	197
IR64610	423	JNA2G246-HC4V	345	JS3012948	326	KL11045	198	KL630-5/16	201
IR64901	423	JNG8HGA-17P	345	JS3012949	326	KL11046	198	KL630-5/8	201
IR64902	423	JNK15A-15P	345	JS3013372	313	KL11047	198	KL63060	197
IR64903	423	JNK15A-17P	345	JS3013851	316	KL11055	198	KL630-7/16	201
IR64904	423	JNK15A-30P	345	JS3013854	316	KL19352	203	KL630-9/16	201
IR64905	423	JNK15A-8P	345	JS3013856	316	KL2100-8	203	KL631	200
IR64907	423	JNK2A-8P	345	JS3013858	316	KL2100-9	203	KL64306	204
IR64908	423	JNK5HGA-17P	345	JS3014874	313	KL27400	203	KL64312	204
IR65101	423	JNK5HGA-30P	345	JS3014879	314	KL27450	203	KL650	203
IR65102	423	JNK5HGA-8P	345	JS3017585	326	KL3210	201	KL662	199
IR65103	423	JS3000001	316	JS3017586	326	KL3211	201	KL663	199
IR65104	423	JS3000061	313	JS3017589	326	KL3212	201	KL70579	275
IR65105	423	JS3000064	313	JS3017593	326	KL3213	201	KL70580	275
IR65108	423	JS3000067	313	JS3020706	315	KL3214	201	KL70581	275
IR66300	424	JS3000070	313	JS3020707	315	KL3219	201	KL70582	275
IR66300	603	JS3000072	313	JS3020708	315	KL3220	201	KL70583	275
IR88601	117	JS3000075	313	JS3020709	315	KL3221	201	KL70586	276
IR88702	117	JS3000078	313	JS3022275	326	KL3222	201	KL70591	275
IR88804	117	JS3000085	313	JS3022276	326	KL3223	201	KL85075	199
IR88805	117	JS3000094	314	JS3022277	326	KL3224	201	KL85076	199
IR88806	117	JS3000095	314	JS3022278	326	KL3238	201	KL85077	199
IR88807	117	JS3000105	314	JS3022279	326	KL3239	201	KLD2000-28	197
IR88808	117	JS3000354	315	JS3022280	326	KL3240	204	KLD2000-48	197
IR88809	117	JS3000356	315	JS3022337	326	KL3241	204	KLD2000-7CST	194
IR88810	117	JS3000357	315	JS3022338	326	KL3242	204	KLD2000-9NE	196
IR88811	117	JS3000358	315	JS3022339	326	KL3244	204	KLD2000-9ST	195
IR88812	117	JS3000359	315	JS3022340	326	KL3245	204	KLD201-6NE	197
IR88813	117	JS3000434	314	JS3022341	326	KL3247	204	KLD201-7CST	194
IR88814	117	JS3000434	617	JS3022342	326	KL32476	200	KLD201-7NE	197
IR88815	117	JS3000436	314	JS3023031	316	KL32477	200	KLD201-8NE	197
IR88816	117	JS3000436	618	JS3023032	316	KL3248	204	KLD201-9NE	197
IR88818	117	JS3000439	618	JS3023033	316	KL32500	200	KLD203-5	195
IR88820	117	JS3000441	314	JS3023034	316	KL32510	200	KLD203-6	195
IR88822	117	JS3000441	618	JS3305336	314	KL3255	204	KLD203-7	195
IR88824	117	JS3000442	314	KC06070	590	KL3256	204	KLD203-8	196
IR88894	116	JS3000442	617	KC34015	590	KL3260	204	KLD203-8N	196
IR88898	116	JS3000447	314	KC41055	330	KL3261	204	KLD203-8NCR	195
IR90106	118	JS3000448	314	KC44314	330	KL3262	204	KLD213-8NE	196
IR90112	118	JS3001742	331	KC44315	330	KL46037	203	KLD213-9	195
IR93553	118	JS3001937	314	KC44322	330	KL500-18	201	KLD213-9NE	196
IT1-1/2	398	JS3001938	314	KC44323	330	KL500-24	201	KLD213-9NE-CR	196
IT112TUNDRA	398	JS3001939	314	KC44324	330	KL506-15	201	KLD213-9NETP	195

Part Number Index

www.edgecs.com



KLD213-9ST.....	195	KN636.....	242	KRS03631.....	422	LC96826.....	424	LOFS1505.....	205
KLD221-5 1/2C.....	196	KN664-0-01.....	238	KRS03631.....	586	LC96832.....	424	LOFS1506.....	205
KLD228-8.....	197	KN665-3-01.....	238	KRS03700.....	422	LE64010103K.....	268	LOFS1508.....	205
KLD232-8.....	195	KN674-0-01.....	239	KRS03700.....	586	LE74204003K.....	268	LOFS1510.....	205
KLD244-5C.....	197	KN69.....	235	KRS03701.....	422	LE830019.....	266	LOFS1512.....	205
KLD248-8.....	197	KN741.....	236	KRS03701.....	586	LE830026.....	267	LOFT1004.....	206
KLD252-6.....	197	KN742.....	236	KRS03702.....	422	LE830033.....	267	LOFT1005.....	206
KLD507-10.....	262	KN743.....	236	KRS03702.....	586	LE830040.....	267	LOFT1006.....	206
KLD507-12.....	262	KN79.....	235	KRS03720.....	585	LE830147.....	267	LOFT1007.....	206
KLD507-6.....	262	KN89.....	235	KRS03725.....	585	LE830161.....	267	LOFT1008.....	206
KLD507-8.....	262	KN90.....	235	KRS03727.....	585	LE830665.....	267	LOFT1010.....	206
KLD511-6.....	196	KN91.....	235	KRS03821.....	422	LE830677.....	268	LOFT1012.....	206
KLD511-8.....	196	KNR-72.....	237	KRS03821.....	586	LE830948.....	268	LOLP-2200-00.....	206
KLJ2000-28.....	197	KRK07095.....	587	KRS03900.....	422	LE831181.....	268	LOLP-2210-00.....	207
KLJ2000-9NE.....	196	KRK07096.....	587	KRS03900.....	586	LE831188.....	268	LOLP-2300-00.....	207
KLJ2000-9ST.....	195	KRK08300.....	586	KRS03901.....	422	LE831425.....	268	LOLP-2921-13A.....	206
KLJ203-8.....	195	KRK08301.....	586	KRS03901.....	586	LF26422.....	217	LOLP-2921-16A.....	206
KLJ213-9NE.....	196	KRK08305.....	586	KRS03911.....	422	LF60101-12.....	217	LOLP-5510-00.....	207
KLJ228-8.....	197	KRK08306.....	586	KRS03911.....	586	LF60101-16.....	217	LOPK100A.....	207
KLJSDS01.....	199	KRK08340.....	586	KRS20848.....	587	LF60101-8.....	217	LOPK100C.....	207
KLJSDS02.....	200	KRK08350.....	586	KRS20857.....	587	LF6100-00291.....	217	LOPK100D.....	207
KLK1210.....	198	KRK08360.....	586	KRTF20009.....	588	LF61001.....	217	LOPK110D.....	207
KLK1412.....	198	KRS00103.....	589	KRTF20027.....	588	LF6A103B.....	217	LST46SQIG-PERF.....	622
KN100.....	235	KRS00208.....	587	KRTF29200.....	588	LFEE1-801T-10.....	217	LST46SQP-ADA-PERF622	
KN10.....	236	KRS00324.....	585	KRWL090000.....	588	LFEE1-801T-3.....	217	LST46SQP-PERF.....	622
KN111.....	236	KRS00325.....	585	KRWL070000.....	588	LFEE1-802T-5.....	217	LST46SQSM-PERF.....	622
KN112.....	236	KRS00326.....	585	KRWL09010.....	582	LFEE2-801-10.....	217	LSULNB4-PERF.....	622
KN11.....	236	KRS00329.....	585	KRWL09023.....	582	LFEE2-801-12.....	217	LSULNB5-PERF.....	622
KN114-0-01.....	238	KRS00332.....	585	KRWL09210.....	582	LFEE2-801-3.....	217	LSULNB6-PERF.....	622
KN116-3-02.....	238	KRS00339.....	585	KRWL09310.....	582	LFEE2-801-4.....	217	LSULRF48-PERF.....	622
KN117-0-02.....	238	KRS00340.....	585	KRWL09410.....	582	LFEE2-801-6.....	217	LSULRF72-PERF.....	622
KN119.....	236	KRS00341.....	585	KRWL09611.....	582	LFEE2-801-8.....	217	LSULRF96-PERF.....	622
KN121-0-01.....	237	KRS00342.....	585	KRWL1111100.....	588	LFEE2-802-10.....	217	LT0050100.....	612
KN1245.....	241	KRS00711.....	589	KRWL30060.....	582	LFEE2-802-12.....	217	LT0050CLR.....	612
KN126-3-02.....	238	KRS00739.....	585	KRWL3333300.....	588	LFEE2-802-14.....	217	LT9003048.....	612
KN127-0-02.....	238	KRS00740.....	585	KSMP301.....	416	LFEE2-802-16.....	217	LT9008040.....	612
KN1275.....	241	KRS00857.....	587	KSMP401.....	416	LFEE2-802-20.....	217	LU1000-15SH.....	224
KN1450.....	243	KRS00880.....	587	KSOTR1810100.....	416	LFEE2-802-3.....	217	LU1500-25SH.....	224
KN162-3-01.....	238	KRS01000.....	585	KSOTR1810200.....	416	LFEE2-802-4.....	217	LU3000-10SH.....	224
KN163-3-01.....	238	KRS01003.....	585	KSOTR1810300.....	416	LFEE2-802-6.....	217	LU3000-30SH.....	224
KN175-3-01.....	240	KRS01005.....	585	KSRR112.....	417	LFEE2-802-8.....	217	LU4000-20SH.....	224
KN176-3-01.....	239	KRS01006.....	585	KSRR182.....	417	LFEE2-803-20.....	217	LU6000-15SH.....	224
KN180-0-01.....	239	KRS01008.....	585	KSRR30.....	417	LFEE2-803-6.....	217	MA192827-3.....	65
KN181-0-01.....	239	KRS01101.....	585	LAD-SAF SYSTEM.....	301	LFEE2-803-8.....	217	MA193157-5.....	65
KN185-3-01.....	240	KRS01110.....	585	LB100.....	368	LFEE2-804-20.....	217	MA193158-3.....	66
KN186-3-01.....	239	KRS01150.....	585	LB100.....	617	LFEN2-802.....	218	MA193159-1.....	65
KN205-3.....	243	KRS01210.....	585	LB170.....	368	LFEN30-4.....	218	MA193890-9.....	65
KN21.....	236	KRS01285.....	585	LB170.....	617	LFEN30-8.....	218	MA2107FK.....	64
KN216-3.....	243	KRS01305.....	585	LB170Ultra.....	368	LFTS1-80230.....	218	MA2414NB.....	64
KN2472.....	235	KRS01310.....	585	LB170Ultra.....	617	LFTS2-80230.....	218	MA2705X1.....	60
KN250.....	243	KRS01415.....	585	LB400.....	368	LI10102BP.....	208	MA4390DW.....	60
KN28.....	235	KRS01470.....	585	LB400.....	617	LI10103BP.....	208	MA5007NK.....	61
KN301-3.....	242	KRS01485.....	585	LB400Ultra.....	368	LI10106.....	208	MA5377MG.....	61
KN30.....	235	KRS01510.....	585	LB400Ultra.....	617	LI10111.....	208	MA5402NA.....	61
KN303-3.....	242	KRS01515.....	585	LBK170.....	368	LI10126BP.....	208	MA5477NB.....	61
KN306-3.....	242	KRS01540.....	585	LBK170.....	617	LOAE2216.....	206	MA6906.....	62
KN3068.....	236	KRS01580.....	585	LBK400.....	368	LOAE2220.....	206	MA792116-2.....	66
KN307-3.....	242	KRS01760.....	585	LBK400.....	617	LOAE2224.....	206	MA792118-8.....	66
KN308-3.....	242	KRS01765.....	585	LBK650.....	368	LOAE2228.....	206	MA9005B.....	63
KN312-3.....	242	KRS01770.....	585	LBK650.....	617	LOAE2232.....	206	MA9031.....	64
KN31.....	236	KRS01800.....	585	LC80130.....	424	LOAE2240.....	206	MA9227C.....	63
KN32.....	235	KRS01811.....	585	LC80141 (Holder).....	424	LOFE3216.....	206	MA9403.....	64
KN33.....	237	KRS01812.....	585	LC80380.....	423	LOFE3220.....	206	MA9557PB.....	62
KN336-3.....	242	KRS01815.....	585	LC80381.....	423	LOFE3224.....	206	MA9557PBX1.....	63
KN337-3.....	242	KRS02001.....	587	LC80382.....	423	LOFE3228.....	206	MA9566CV.....	63
KN338-3.....	242	KRS03500.....	422	LC80383.....	423	LOFE3232.....	206	MA9741.....	64
KN350-3-01.....	239	KRS03500.....	586	LC80385.....	423	LOFE7236.....	205	MA9903.....	64
KN352-3-01.....	239	KRS03600.....	422	LC80386.....	423	LOFE7240.....	205	MAA-90532.....	66
KN354-3-01.....	239	KRS03600.....	586	LC84810.....	424	LOFM1414HD.....	205	MAA-90956.....	66
KN356.....	240	KRS03611.....	422	LC84811.....	424	LOFM1416HD.....	205	MAB9000.....	66
KN360-3-01.....	239	KRS03611.....	586	LC84812.....	424	LOFM1504.....	205	MABCS550.....	57
KN36.....	235	KRS03612.....	422	LC84813.....	424	LOFM1505.....	205	MABDA350.....	58
KN372-0-01.....	239	KRS03612.....	586	LC84814.....	424	LOFM1506.....	205	MABDF451.....	56
KN396-0-01.....	239	KRS03613.....	422	LC84815.....	424	LOFM1507.....	205	MABDF452HW.....	57
KN41.....	236	KRS03613.....	586	LC84816.....	424	LOFM1508.....	205	MABGA452Z.....	58
KN42.....	235	KRS03614.....	422	LC85400.....	424	LOFM1510.....	205	MABHP454.....	56
KN44.....	236	KRS03614.....	586	LC85490.....	424	LOFM1512.....	205	MABJR181.....	57
KN4824.....	235	KRS03620.....	422	LC96222.....	424	LOFS1404HD.....	205	MABJV180.....	58
KN4830.....	235	KRS03620.....	586	LC96223.....	424	LOFS1406HD.....	205	MABL1815.....	59
KN51.....	236	KRS03621.....	422	LC96820.....	424	LOFS1408HD.....	205	MABL1830.....	60
KN530-3-01.....	242	KRS03621.....	586	LC96821.....	424	LOFS1410HD.....	205	MABL7010.....	66
KN536-3-01.....	242	KRS03622.....	422	LC96822.....	424	LOFS1412HD.....	205	MABML185.....	58
KN60.....	235	KRS03622.....	586	LC96823.....	424	LOFS1502.....	205	MABMR100W.....	65
KN631.....	242	KRS03630.....	422	LC96824.....	424	LOFS1503.....	205	MABPB180.....	57
KN63.....	236	KRS03630.....	586	LC96825.....	424	LOFS1504.....	205	MABTD141.....	56

Spokane, WA 509-535-9841

Billings, MT 406-248-7196



MABTD142HW	57	MB82894	558	MH12T	616	MI48-00-5026	103	MI48-42-2310	105
MABTP140	56	MB82900	558	MH24T	370	MI48-00-5027	103	MI48-42-2311	105
MABTW450	57	MB82916	558	MH24T	616	MI48-00-5031	102	MI48-42-5121	105
MABVR450	59	MB84636	557	MI0101-20	50	MI48-00-5035	102	MI48-42-5161	105
MADA3010F	61	MB84639	557	MI0200-20	49	MI48-00-5036	102	MI48-42-5166	105
MADA4031	61	MB84640	557	MI0201-20	50	MI48-00-5037	102	MI48-42-5190	105
MADC1804	65	MB85002	557	MI0234-6	49	MI48-00-5041	102	MI48-42-5192	105
MADC1822	65	MB85004	557	MI0299-20	50	MI48-00-5052	104	MI48-42-5300	105
MADC18RA	65	MB85055	557	MI0302-20	50	MI48-00-5090	102	MI48-42-5310	105
MADP4000	61	MB85082	614	MI0370-20	51	MI48-00-5091	102	MI48-42-5311	105
MADPC7331	62	MB89215	613	MI0719-22	48	MI48-00-5092	102	MI48-42-5540	105
MAG782.12.0516	118	MB89223	613	MI0726-22	47	MI48-00-5093	102	MI48-42-5850	105
MAG911.1016	118	MB89253	613	MI0729-21	48	MI48-00-5094	102	MI48-59-1801	43
MAG911.1116	118	MB89263	613	MI0730-22	47	MI48-00-5162	102	MI48-59-2401	47
MAG911.1216	118	MB89287	613	MI0756-22	47	MI48-00-5163	102	MI48-59-2818	43
MAG911.1316	118	MB89319	613	MI0779-22	47	MI48-00-5181	102	MI48-95-0400	56
MAG911.1416	118	MB89348	613	MI0928-29	48	MI48-00-5182	102	MI49-12-0365	53
MAG911.1516	118	MB89362	613	MI1107-6	51	MI48-00-5183	102	MI49-22-0065	111
MAG911.1616	118	MB89363	613	MI1250-1	51	MI48-00-5184	102	MI49-22-0130	111
MAG911.1816	118	MB89377	614	MI1610-1	50	MI48-00-5185	102	MI49-22-0135	110
MAG911.2016	118	MB89395	613	MI1630-1	50	MI48-00-5186	102	MI49-22-0220	102
MAGA4530	63	MB89474	614	MI1660-6	50	MI48-00-5187	102	MI49-22-1131	104
MAGA9020	63	MB89478	614	MI1675-6	51	MI48-00-5188	102	MI49-22-8510	55
MAGD0601	63	MB89480	614	MI1676-6	51	MI48-00-5189	102	MI49-24-0171	43
MAGD0800C	63	MB89602	614	MI1680-20	51	MI48-00-5193	102	MI49-24-0185	48
MAHM0810B	62	MB89696	614	MI1680-21	51	MI48-00-5194	102	MI5192	53
MAHM1810X	62	MB89697	614	MI1854-1	50	MI48-00-5282	102	MI5194	53
MAHR2475	62	MB89698	614	MI2205-20	45	MI48-00-5284	102	MI5211	53
MAHR4001C	62	MB89700	614	MI2217-20	45	MI48-00-5286	102	MI5455	53
MAJR3070CT	60	MB89701	614	MI2236-20	46	MI48-00-5701	103	MI5460-6	53
MAJS8000	65	MB89757	614	MI2237-20	46	MI48-00-5706	103	MI5540	53
MAKP0800K	64	MB89772	614	MI2266-20	46	MI48-00-5711	103	MI6088-20	53
MALCT200W	58	MB89889	613	MI2280-20	46	MI48-00-5713	102	MI6101-6	53
MALS1016L	60	MB89899	613	MI2290-21	45	MI48-00-5782	102	MI6116-30	52
MALS1216L	60	MB89922	613	MI2310-21	47	MI48-00-5784	102	MI6116-31	52
MALXT211	58	MCTS1	122	MI2401-22	43	MI48-00-5787	102	MI6140-30	52
MALXT218	58	MCTSFC	122	MI2410-22	44	MI48-00-5789	102	MI6148-30	52
MALXT407	59	MCTSHD	122	MI2420-22	45	MI48-00-8026	103	MI6176-20	55
MALXT601	59	MDWP6510L	265	MI2426-22	44	MI48-00-8784	102	MI6190-20	55
MALXT702	59	MDWP6510R	265	MI2432-22	45	MI48-00-8788	102	MI6230N	54
MAMAC5200	348	MDWP6510S	265	MI2450-22	43	MI48-01-6031	102	MI6232-6N	54
MAMAC700	347	MDWP6716L	265	MI2471-22	46	MI48-01-6035	102	MI6236N	54
MAPC5000C	65	MDWP6716R	265	MI2601-22	41	MI48-01-6036	102	MI6238N	54
MARCS6364N	435	MDWP6716S	265	MI2610-24	40	MI48-01-6182	102	MI6242-6	54
MARCS6365N	435	MG1361	321	MI2611-24	40	MI48-01-6184	102	MI6370-21	55
MAS1457VE3KA	603	MG1700L	321	MI2620-22	42	MI48-01-6185	102	MI6390-21	49
MAS1	602	MG1700XL	321	MI2629-22	42	MI48-01-6186	102	MI6470-21	49
MAS175	603	MG1965-L	321	MI2630-22	43	MI48-01-6188	102	MI6509-31	49
MAS175LH	603	MG1966-L	321	MI2632-20	42	MI48-01-7021	103	MI6523-21	49
MAS1KA	602	MG3211-L	321	MI2632-22	41	MI48-01-7784	102	MI6536-21	49
MAS1KALJ	602	MG3211-M	321	MI2650-22	41	MI48-06-2860	56	MI6562-21	48
MAS1UP	602	MG3211-S	321	MI2663-22	41	MI48-08-1080	48	MI6790-20	51
MAS1UPLJ	602	MG3211-XL	321	MI2710-20	43	MI48-11-1024	48	MI6791-21	51
MAS3	602	MG3211-XS	321	MI3002-1	51	MI48-11-1815	42	MI6852-20	55
MAS3KA	602	MG3211-XXL	321	MI3107-6	51	MI48-11-1828	42	MI6890	55
MAS3UP	602	MG3460-L	321	MI4202	54	MI48-11-2230	43	MI8975-6	55
MAS3UPLF	602	MG3460-M	321	MI4210-1	54	MI48-11-2401	47	MI8977-20	55
MAS410BLU	603	MG3460-S	321	MI4262-1	54	MI48-11-2402	47	MI8980	55
MAS410GRN	603	MG3460-XL	321	MI4270-21	54	MI48-11-2830	48	MI9070-20	52
MAS410RED	603	MG3555-L	321	MI48-00-1301	103	MI48-25-1001	110	MI9075-20	52
MAS410YLW	603	MG3555-M	321	MI48-00-1303	103	MI48-25-1121	110	MID00378	429
MAS420	603	MG3555-XL	321	MI48-00-1420	102	MI48-25-1251	110	MID00391	429
MAS497AX	603	MG4740	322	MI48-00-1420	103	MI48-25-1371	110	MIDL100	429
MAS5	602	MG5030-L	322	MI48-00-1440	103	MI48-25-1501	110	MIDL75	429
MAS5KA	602	MG5030-XL	322	MI48-00-1450	103	MI48-25-1751	110	MIN10034018	315
MAS5UP	602	MG5049-L	322	MI48-00-1600	104	MI48-25-2001	110	MIN473334	315
MAS5UPLF	602	MG5199B	323	MI48-00-1610	104	MI48-25-2121	110	MIN475358	315
MAS8401D	603	MG5199E	323	MI48-00-4091	104	MI48-25-2251	110	MIN475359	315
MAS8405D	603	MG5308	323	MI48-00-4093	104	MI48-25-2561	110	MIN475360	315
MAS8406D	603	MG5309	323	MI48-00-4182	104	MI48-25-3001	110	MIN475361	315
MAS8412D	603	MG5310	323	MI48-00-4184	104	MI48-25-3621	110	MIN475362	315
MAS8430D	603	MG6100S	322	MI48-00-4186	104	MI48-25-4125	110	MIN475363	315
MATD020DSEW	60	MG6212SJ	322	MI48-00-4187	104	MI48-25-4621	110	MIN475395	315
MB82165	558	MG6454S	322	MI48-00-4188	104	MI48-28-1030	111	MIN475407	315
MB82186	558	MG6514SJ	323	MI48-00-4712	104	MI48-28-1040	111	MIN696688	315
MB82193	558	MG7100P	322	MI48-00-4713	104	MI48-28-1050	111	MJ3435-L	324
MB82220	557	MG7102	322	MI48-00-4782	104	MI48-28-1060	111	MJ3435-M	324
MB82249	557	MG8100C	322	MI48-00-4784	104	MI48-42-0801	105	MJ3435-XL	324
MB82295	558	MG8802	322	MI48-00-4787	104	MI48-42-0850	105	MKAT12	106
MB82307	558	MG8808	322	MI48-00-4788	104	MI48-42-2120	105	MKAT14	106
MB82329	557	MG9500LM	322	MI48-00-5012	102	MI48-42-2160	105	MKAT16	106
MB82487	558	MG9500MM	322	MI48-00-5015	102	MI48-42-2190	105	MKAT18	106
MB82517	557	MG9500XSM	322	MI48-00-5016	102	MI48-42-2192	105	MKAT20	106
MB82539	557	MG9622	322	MI48-00-5017	102	MI48-42-2300	105	MKAT22	106
MB82859	557	MH12T	370	MI48-00-5021	103	MI48-42-2302	105	MKAT24	106



Part Number Index

www.edgecs.com

MKAT26	106	MKAV70	106	MKMK34	108	MQQP2TH	364	MTW14-150ERGO	77
MKAT32	106	MKAV72	106	MKMK345	108	MRT00001	371	MTW14-150QUICK	77
MKAT36	106	MKAV76	106	MKMK36	108	MRT00047	371	MTW8-115	77
MKAT38	106	MKAV80	106	MKMK37	108	MS10	391	MV39000	282
MKAT40	106	MKAV88	106	MKMK38	108	MS11	393	MV39001	282
MKAT44	106	MKAV92	106	MKMK385	108	MS120D	389	MX2200N95	320
MKAT48	106	MKAV96	106	MKMK40	108	MS124B	390	MX2306N95	320
MKAT56	106	MKCSM1080AC	78	MKMK41	108	MS13080	393	MX2600N95	320
MKAT58	106	MKCSM1260NSC	78	MKMK42	108	MS13081	393	MX2700N95	320
MKAT64	106	MKCSM1280AC	78	MKMK425	108	MS13082	393	MX2730N10	320
MKAT68	106	MKCSM1280TSC	78	MKMK435	108	MS13083	393	MX2800N95	320
MKAT72	106	MKCSM1466NSC	78	MKMK44	108	MS13084	393	MX6604	320
MKAT80	106	MKCSM1480AC	78	MKMK46	108	MS142	390	MY17D-1	308
MKAT88	106	MKCSM1490SSC	78	MKMK475	108	MS145D	390	MY195R-2-25	307
MKAT96	106	MKCSM1490TSC	78	MKMK48	108	MS145SH	390	MY195R-2-50	307
MKATCG12	107	MKCSM14B	77	MKMK50	108	MS146D	390	MY210WLS	304
MKATCG14	107	MKCSM53830SC	78	MKMK5156PD	109	MS150	389	MY216M	304
MKATCG16	107	MKCSM53850AC	78	MKMK52	108	MS151	389	MY216TWLS	305
MKATCG18	107	MKCSM53850TSC	78	MKMK54	108	MS152	389	MY219M/6FTGN	304
MKATCG19	107	MKCSM65040SC	78	MKMK56	108	MS162B	389	MY231M/6FTGN	304
MKATCG20	107	MKCSM65048TSC	78	MKMK58	108	MS163B	389	MY232M	304
MKATCG22	107	MKCSM72540SC	78	MKMK60	108	MS166B	389	MY232TWLS	305
MKATCG24	107	MKCSM72548NSC	78	MKMK62	108	MS167B	389	MY300L-10	307
MKATCG26	107	MKCSM72560AC	78	MKMK63	108	MS174B	393	MY300L-2	307
MKATCG28	107	MKCSM72568TSC	78	MKMK64	108	MS175B	393	MY300L-5	307
MKATCG32	107	MKCSM7MB	78	MKMK66	108	MS17-6ASU	391	MY300L-7	307
MKATCG36	107	MKCSM9MB	78	MKMK68	108	MS180D	391	MY470	307
MKATCG38	107	MKESD01	118	MKMK70	108	MS1D	391	MY496	307
MKATCG40	107	MKESD02	118	MKMK72	108	MS207	394	MY6414N-L	304
MKATCG44	107	MKESD03	118	MKMK76	108	MS28L	391	MY6414N-M	304
MKATCG48	107	MKESD04	118	MKMK7700G	109	MS33 11FG	393	MY6414N-S	304
MKATCG56	107	MKESD05	118	MKMK80	108	MS36D	389	MY650T-58	303
MKATCG58	107	MKESD06	118	MKMK84	108	MS38	390	MY6756RS	305
MKATCG64	107	MKESD07	118	MKMK8600P	109	MS402	391	MY751L/XL	303
MKATCG72	107	MKESD08	118	MKMK88	108	MS40	390	MY8174MLS	307
MKATCG80	107	MKESD09	118	MKMK92	108	MS4510D	391	MY8174X	307
MKATCG88	107	MKM24K	107	MKMK96	108	MS4512D	391	MY8183	307
MKATCG96	107	MKM34	107	MKMPD4CT01	109	MS4615	389	MY8187V	308
MKAV02E	107	MKM35PS	107	MKMPD4N01	109	MS46G	390	MY8428-15-XL	303
MKAV04P	107	MKM44	107	MKZWEP5318WS	110	MS521	389	MY8428-15-XXL	303
MKAV08E	107	MKM45	107	MKZWEPXTL441014	110	MS52D	393	MY850-4	303
MKAV09	106	MKM45P	107	MKZWEPXTL441418	110	MS54	393	MY8798B-SN	305
MKAV10	106	MKME12	109	MKZWEPXTL442024	110	MS6523	389	MY8798RSS	305
MKAV11	106	MKMK03	109	MLK3A016	433	MS800	391	MY8798SS	305
MKAV12	106	MKMK04	109	MLLM2A001	433	MS820	392	MY9014	304
MKAV13	106	MKMK05	109	MLLM3A001	433	MS820B	392	MY9077	304
MKAV14	106	MKMK0600L	109	MLLWSA201	433	MS822	392	MY907NLS/6FTYL	305
MKAV15	106	MKMK06	109	MLLWSA301	433	MS825	392	MY9099X	304
MKAV16	106	MKMK09	108	MLM2A016	433	MS826	392	MY910WLS	305
MKAV17	106	MKMK10	108	MLM3A016	433	MS828	392	MY913B-SN	305
MKAV18	106	MKMK105	108	MLS2D016	433	MS829	389	MY928LS	305
MKAV19	106	MKMK11	108	MLS3D016	433	MS836	390	MYE650-58SN	304
MKAV20	106	MKMK12	108	MLSP2201H	433	MS841	388	MYE650-77	304
MKAV21	106	MKMK125	108	MLST2D016	433	MS847	388	MYFL11-3	306
MKAV22	106	MKMK13	108	MOT53862	334	MS893	392	MYFL11-6	306
MKAV23	106	MKMK14	108	MOTRDU4100	333	MS97	394	MYMFL-11/6FT	306
MKAV24	106	MKMK15	108	MOTRKN4155	334	MSAP738	392	MYMFL-12/6FT	306
MKAV25	106	MKMK155	108	MOTRLN6305	333	MSAP753H	392	MYMFLB	306
MKAV26	106	MKMK16	108	MOTRLN6309	334	MSAP867H-5	392	MYMP20G/20FT	306
MKAV27	106	MKMK17	108	MOTRLN6351	334	MSB42	390	MYMP30G/30FT	306
MKAV28	106	MKMK18	108	MOTXTI	334	MSB45	390	MYMR50GC	308
MKAV29	106	MKMK185	108	MPJACKSFL	207	MSB48	390	MYPFL-4	306
MKAV30	106	MKMK19	108	MPJACKXFL	207	MSB48FR	390	MYPFL-6	306
MKAV32	106	MKMK20	108	MPP1614	208	MSB5-72	391	MYRA20-1	307
MKAV33	106	MKMK204	108	MPP2014	208	MSBG48	390	MYRA40	308
MKAV34	106	MKMK205	108	MPP2414	208	MSC24R	394	MYRDT-QC-BDP/U	302
MKAV36	106	MKMK21	108	MPP2814	208	MSC30R	394	MYRDT-QC-BDP/XXL	302
MKAV37	106	MKMK21200L	109	MPP3214	208	MSC36R	394	MYRDT-QC/SM	302
MKAV38	106	MKMK22	108	MQ1400HD	395	MSC48R	394	MYRDT-QC/U	302
MKAV40	106	MKMK224	108	MQ1700HD	395	MSMXS205	393	MYRDT-QC/XXL	302
MKAV41	106	MKMK225	108	MQ2100HD	395	MSMXS205FR	393	MYRDT-TB/U	302
MKAV42	106	MKMK23	108	MQ314V-10	394	MSMXS205RD	393	MYRIA-B1	303
MKAV44	106	MKMK24	108	MQ314V-7	394	MSMXS20D	393	MYRIA-B2	303
MKAV46	106	MKMK244	108	MQCV1	394	MSMXS57D	393	MYRIA-BL	303
MKAV48	106	MKMK25	108	MQCV2	394	MSMXS60D	393	MYRIA-C1	303
MKAV50	106	MKMK255	108	MQCV3	394	MSMXS64D	393	MYRIA-C2	303
MKAV52	106	MKMK26	108	MQFS10	394	MSMXS66D	393	MYRIA-K2	302
MKAV54	106	MKMK27	108	MQFS14	394	MSMXS66RE	393	MYRIA-P1	303
MKAV56	106	MKMK28	108	MQFS7	394	MSMXS81D	393	MYRIA-R2	302
MKAV58	106	MKMK285	108	MQJ36H55-QXH	394	MSMXS81FRD	393	MYRIA-R4	302
MKAV60	106	MKMK29	108	MQMC3-PE	394	MST34	392	MYRIA-RD	303
MKAV62	106	MKMK30	108	MQMTX70	364	MT655993000	77	MYRIA-T10	302
MKAV64	106	MKMK315	108	MQMTX70	395	MT655996000	77	MYRIA-T1	302
MKAV66	106	MKMK32	108	MQMVC82VHW	395	MT655997000	77	MYRIA-T2	302
MKAV68	106	MKMK33	108	MQMVH206GH	395	MT655998000	77	MYRIA-T3	302

Spokane, WA 509-535-9841

Billings, MT 406-248-7196

670

Yakima, WA 509-248-1144

Gillette, WY 307-682-8522



MYRIA-T4	302	NU69-027	290	PA650213	538	PCO120	607	PF11028	271
MYRIA-T5	302	NU69-048	290	PA650214	538	PCO122	607	PF11029	271
MYRIA-T6	302	NU69-109	290	PA650215	538	PCO1501	607	PF11032	271
MYRIA-T7	302	NU69-127	291	PA650230	537	PCO1502	607	PF11054	271
MYRIA-T8	302	NU69-148	291	PA650231	537	PCO150	607	PF11059	271
MYRIA-T9	302	NU69-150	290	PA650232	537	PCO150U	608	PF11067P	271
MYRIA-YL	303	NU69-215	292	PA650236	537	PCO152	607	PF11073	271
MYRKNAR-QC/UBK	302	NU69-223	291	PA650237	537	PCO152U	608	PF11076	271
MYRKNAR-TB/UBK	302	NU69-276	291	PA650238	537	PCO1601	608	PF11087	272
MYRL20P	306	NU69-277	291	PA650239	537	PCO1602	608	PF11100P	271
MYRL65G	306	NU69-351	292	PA650272	537	PCO1603	608	PF11104	272
MYRLS30G/30	306	NU69-401	291	PA650273	537	PCO1605	608	PF11105	271
MYT4007	304	NU69-403	291	PA650281	537	PCO160	608	PF11130	272
MYVG/110FT	308	NU69-548	291	PA650282	537	PCO161	608	PF11131	272
MYVG/30FT	308	NU69-616	291	PA650283	537	PCO162	608	PF11132	272
MYVG/50FT	308	NU69-799	291	PA650284	537	PCO165	608	PF11133	272
MYVG/70FT	308	NU72-145	291	PA650285	537	PCO170	608	PF11135P	272
NE101	583	NU72-245	291	PA650287	537	PCO172	608	PF19001P	272
NE111	583	NU79-314	291	PA650341	540	PCO3002	609	PF19003	272
NE125	583	NW5RC	610	PA650342	540	PCO3003	609	PF19004P	272
NE188	583	OA2000V	87	PA650381	537	PCO40014	609	PF19010	272
NE250	584	OA2200C	87	PA650382	537	PCO5801	607	PF24033	558
NE255	584	OA2200UL	87	PA650383	537	PCO5802	607	PF24063	558
NE535-XSP	584	OI1020004	582	PA650384	537	PCO580	607	PF24065	558
NE620-AL	584	OI1183480	583	PA650385	537	PCO581	607	PF24103	558
NE624	584	OI841989	583	PA650386	537	PCO5901	608	PF24113	558
NE632	584	OIF-38	582	PA650387	537	PCO5902	608	PF24283	560
NEOV-17	584	OIQB-300	583	PA650388	537	PCO5903	608	PF24292	560
NEOV-18	584	OISC-175	583	PA650476	537	PCO5904	608	PF24293	560
NEOV-21	584	OISF-450	582	PA650522	538	PCO601	608	PF24343	560
NEOV-25	584	OR11-627-10	323	PA650523	538	PCO606-S	608	PF24393	560
NEPC-58	584	OR11-627-11	323	PA650525	538	PCOATL004	609	PF24423	560
NEPC-620	584	OR11-627-8	323	PA650526	538	PCOATL004W	609	PF24463	560
NER-10	584	OR11-627-9	323	PA650535	538	PCOATL016	609	PF24473	560
NER-11	584	OZ1.8OZ	396	PA650563	538	PCOATL016W	609	PF24483	560
NESPT-10S	584	OZ2.4OZ	396	PA900078	539	PCOATL128	609	PF24513	560
NESPT-3P	584	OZFS10OZ	396	PA900600	536	PCOATL128W	609	PF24543	560
NK302001492	84	OZFS14OZ	396	PA901000	536	PCOCH09	608	PF24563	560
NK900131	84	OZFS21OZ	396	PA902000	535	PCOCH10	608	PF24593	560
NMC151RB	334	OZH175OZ	396	PA902200	535	PCOGF60245Q	607	PF24633	560
NMD125RB	334	P2860-33VY	448	PACHLE1000	411	PCOGF60504Q	607	PF24643	560
NMD132RB	334	PA092055	540	PACHVL100	411	PCOGF61004Q	607	PF24693	560
NMD247RB	334	PA092056	540	PACHVR505G	411	PCOGFRM0604SR	607	PF24703	560
NMD404RB	334	PA092057	540	PACHVR505R	411	PCOPFE40504 Color	606	PF24733	560
NMD46RB	334	PA092058	540	PACPLS-10061	412	PCOPFE41004 Color	606	PF24753	560
NMD79RB	334	PA092059	540	PACPLS10090	411	PCOPHS0406	607	PF24783	561
NMD9RB	334	PA092062	540	PACPLS180SYSTEM	410	PCOPHS0609	607	PF24793	561
NMN119RB	334	PA0T2250	540	PACPLS180TOOL	410	PCOT004	609	PF24803	561
NMSF47RB	334	PA0T2258	540	PACPLS-20309	412	PCOT006	609	PF24813	561
NO550046	87	PA0T2695	540	PACPLS-20513	412	PDIAC1	609	PF24863	561
NO550047P	87	PA0T2851	540	PACPLS3	410	PDIAM0	609	PF25143	561
NO550048	87	PA0T2855	540	PACPLS360ESYSTEM410	410	PDIAM11	609	PF25153	561
NO860139	87	PA0T5238	540	PACPLS360ETOOL	410	PDIAM12	609	PF25163	561
NO860243	87	PA0T5240	540	PACPLS5SYSTEM	411	PDIAM13	609	PF25213	561
NO860249	87	PA0T5242	540	PACPLS5TOOL	410	PDIAM1	609	PF25222	561
NOPS2009	86	PA219247	541	PACPLS90SKIT	411	PDIAM2	609	PF25253	561
NOSC2005	87	PA219348	589	PACPLS-HVD	412	PDIAM3	609	PF43410	566
NU10-035	289	PA400026	538	PACPLSSLD	411	PDIAM5	609	PF43412	566
NU12-495	291	PA401301	539	PATBBD 12D	359	PDIAM6	609	PF43446	567
NU13-120	290	PA402500	541	PATBBD 12DS	359	PDIAM7	609	PF43447	567
NU21-008	289	PA403471	540	PATBBD 12TS-01	359	PDIAM8	609	PF43449	567
NU21-012	289	PA404068	540	PATBBD 15E	358	PDIAMB	609	PF43450	567
NU21-017	289	PA404069	540	PATBBD 15ET	358	PDIAMC	609	PF43453	567
NU21-020	289	PA404070	540	PATBBD 2T-01	359	PDIAWR4	609	PF43458	567
NU21-024	289	PA404071	540	PATTEX 09PS	358	PDP300B	415	PF44600	567
NU21-025	289	PA404479	541	PATTEX 09PSK	358	PDP300R	415	PF44606	567
NU21-033	289	PA405000	537	PATTEX 117	358	PDP302	415	PF44609	567
NU27-101	289	PA405253	537	PATTEX 12PSK	358	PDP327	416	PF45185	564
NU27-808	290	PA500855	536	PATTEX 150PE	357	PDP397	415	PF45208	564
NU27-810	290	PA500910	536	PATTEX 190PE	357	PEUC-7308	124	PF45209	564
NU27-812	290	PA500959	537	PATTEX 230 PE	357	PEUC-7330	124	PF45233	564
NU27-816	290	PA501000	536	PATTEX 280PE	357	PEUC-7408	125	PF45238	564
NU29-020	289	PA501230	540	PATTEX 33PE	357	PEUC-7422	125	PF45239	564
NU29-030	289	PA501260	540	PATTEX 40PE	357	PEUC-7430	124	PF45240	564
NU30-025	290	PA501265	540	PB10-CD	67	PEUC-7661	124	PF45241	564
NU30-040	290	PA501270	539	PBF KIT	124	PEUC-9196	124	PF45242	564
NU39-012	292	PA501680	536	PBTE709165	428	PF11007P	271	PF45466	564
NU55-551	292	PA650014	538	PBTE709187	428	PF11009	271	PF45467	564
NU59-801	292	PA650025	538	PBTE712500	428	PF11010P	271	PF45473	564
NU59-987	292	PA650026	538	PBTE712505	428	PF11012	271	PF45474	564
NU68-446	292	PA650027	538	PBTE712600	428	PF11013	271	PF45481	564
NU68-448	292	PA650028	538	PBTE712605	428	PF11015	271	PF45483	564
NU68-555	292	PA650039	539	PBTE712810	429	PF11016	271	PF61000	570
NU69-001	292	PA650210	537	PCO1202	607	PF11023P	271	PF61001	570
NU69-010	290	PA650212	538	PCO1203	607	PF11026	271	PF61002	570

Part Number Index

www.edgecs.com



PF61003.....	570	PF62276.....	566	PF69203.....	569	PO408C.....	596	PRMFS1585.....	531
PF61004.....	570	PF62278.....	566	PF69259.....	569	PO410B.....	596	PRMFS200.....	531
PF61005.....	570	PF62288.....	566	PF69303.....	569	PO410C.....	596	PRMFT1034.....	532
PF61006.....	570	PF62290.....	566	PF69305.....	569	PO420B.....	596	PRMGRSL34RD2.....	610
PF61007.....	570	PF62361.....	565	PF69309.....	569	PO420C.....	596	PRMGRTNSNR34.....	610
PF61008.....	570	PF62362.....	565	PF69317.....	569	PO420FR.....	596	PRMGS158.....	533
PF61011.....	570	PF62363.....	565	PF69337.....	572	PO610C.....	596	PRMGS1585.....	533
PF61104.....	571	PF62383.....	565	PF69344.....	572	PO620B.....	596	PRMGS200.....	533
PF61105.....	571	PF62402.....	564	PF69403.....	569	PO620C.....	596	PRMGS2005.....	533
PF61106.....	571	PF62403.....	564	PF69405.....	569	PO620FR.....	596	PRMGS212.....	533
PF61108.....	571	PF62406.....	564	PF69409.....	569	PO620W.....	596	PRMGS2125.....	533
PF61110.....	571	PF62451.....	564	PF69420.....	569	POHKHM42050B.....	615	PRMGS300.....	533
PF61301.....	571	PF62452.....	564	PF69603.....	569	POHWY-4-55.....	615	PRMGS3005.....	533
PF61304.....	571	PF62453.....	564	PF69606.....	569	POPA2042HB.....	615	PRMGS400.....	533
PF61306.....	571	PF62454.....	564	PF69832.....	570	PP5400.....	230	PRMGS4005.....	533
PF61500.....	571	PF62455.....	564	PF69834.....	570	PP5419.....	230	PRMHWD10100.....	533
PF61501.....	571	PF62456.....	564	PF69842.....	570	PP5500.....	230	PRMHWD48100.....	531
PF61502.....	571	PF62457.....	564	PF69846.....	570	PPA219228.....	540	PRMHWD48112.....	531
PF61504.....	571	PF62701.....	564	PF69862.....	570	PPA219236.....	539	PRMHWD4812.....	531
PF61506.....	571	PF62702.....	564	PF69865.....	570	PPA219348.....	539	PRMHWD48125.....	531
PF61507.....	571	PF62703.....	564	PF69945.....	569	PPA401482.....	539	PRMHWD48200.....	531
PF61508.....	571	PF62704.....	564	PF69960.....	569	PPA404717.....	539	PRMHWD4834.....	531
PF61602.....	571	PF62705.....	564	PFG300PC-L.....	323	PPA900200.....	541	PRMHW510100.....	531
PF61604.....	571	PF62706.....	564	PFG300PC-M.....	323	PPS144.....	224	PRMHW510112.....	531
PF61605.....	571	PF62708.....	564	PFG300PC-S.....	323	PPS72A.....	224	PRMHW5101125.....	531
PF61607.....	571	PF62945.....	566	PFG300PC-XL.....	323	PR034040.....	376	PRMHW510200.....	531
PF61608.....	571	PF62947.....	566	PF62940.....	323	PR173120.....	376	PRMHW5102005.....	531
PF61703.....	571	PF62955.....	566	PF6390-L.....	323	PR20EVSNK.....	70	PRMHWD10100.....	532
PF61704.....	571	PF63101.....	568	PF6390-S.....	323	PR966006503.....	376	PRMHWD101005.....	532
PF61766.....	567	PF63102.....	568	PF6390-XL.....	323	PR966844801.....	375	PRMHWD101125.....	532
PF61767.....	567	PF63103.....	568	PFG451PC-L.....	323	PR966845301.....	375	PRMHWD1012.....	532
PF61771.....	567	PF63104.....	568	PFG451PC-M.....	323	PREL 10 CnB.....	376	PRMHWD1034.....	532
PF61772.....	567	PF63106.....	568	PF6451PC-S.....	323	PREL 35 CnB.....	376	PRMHWD10345.....	532
PF61801.....	567	PF63111.....	568	PFG451PC-XL.....	323	PREL 70 CnB.....	376	PRMHWD120345.....	533
PF61802.....	567	PF63112.....	568	PF6541-L.....	323	PRFS 400.....	378	PRMHWD12100.....	533
PF61803.....	567	PF63114.....	568	PF6541-XL.....	323	PRFS 4800 D 30.....	378	PRMHWD121005.....	533
PF61805.....	568	PF63115.....	568	PIAHA-100.....	548	PRFS 627 20.....	378	PRMHWD121125.....	533
PF61806.....	568	PF63119.....	568	PIATA-17.....	548	PRFS 6600 D 36.....	378	PRMHWD122005.....	533
PF61807.....	568	PF63162.....	569	PIK64062.....	548	PRK 3000.....	377	PRMHWD14100.....	532
PF62009.....	564	PF63163.....	569	PIK64075.....	548	PRK3000CUT-N-BREAK.....	375	PRMHWD812.....	532
PF62010.....	564	PF63164.....	569	PIK66062.....	548	PRK3000WET14.....	375	PRMHSWD834.....	532
PF62011.....	564	PF63172.....	569	PIK66075.....	548	PRK760-12.....	375	PRMLS10112.....	531
PF62012.....	564	PF63174.....	569	PIPC-2S13KES-20.....	548	PRK760-14.....	375	PRMLS101125.....	531
PF62014.....	565	PF63202.....	568	PIPC-2S22KES-40.....	548	PRK760-14.....	375	PRMMT114.....	531
PF62015.....	565	PF63204.....	568	PIPT-1500Z-ER1.....	548	PRK 760.....	377	PRMMT1145.....	531
PF62028.....	564	PF63309.....	570	PIPT-2000Z-ER1.....	548	PRK970-14.....	374	PRMMT812.....	531
PF62029.....	564	PF63402.....	572	PIPT-400Z-ER1.....	548	PRK970-16.....	374	PRMMT8125.....	531
PF62030.....	564	PF63403.....	572	PISDK61075.....	548	PRM10HGC.....	533	PRMMD1034.....	532
PF62031.....	564	PF63404.....	572	PISDK63075.....	548	PRM112HGJST.....	534	PRMMD8114.....	532
PF62033.....	565	PF63405.....	572	PIT1/2X300.....	609	PRM114HGJST.....	534	PRMMD81145.....	532
PF62034.....	565	PF63409.....	572	PIT1X300.....	609	PRM12C.....	533	PRMMD812.....	532
PF62052.....	565	PF63414.....	572	PIT3/4X300.....	609	PRM12CTDSKR.....	534	PRMMD8125.....	532
PF62124.....	566	PF63842.....	568	PIT3/4X50.....	609	PRM12HGC.....	533	PRMP158STGD.....	533
PF62125.....	566	PF63843.....	568	PIT3/8X100.....	609	PRM134EGRFG.....	534	PRMP3STGD.....	533
PF62126.....	566	PF63845.....	568	PIT3/8X25.....	609	PRM16C.....	533	PRMPPH10585.....	532
PF62140.....	565	PF64012.....	568	PIT3/8X50.....	609	PRM16CTDSKR.....	534	PRMSD114.....	532
PF62142.....	565	PF64014.....	568	PJA14273.....	123	PRM16DUP.....	534	PRMSD1145.....	532
PF62144.....	565	PF64018.....	568	PJA30052.....	123	PRM16HGC.....	533	PRMSD158.....	532
PF62146.....	565	PF64121.....	568	PJA30248.....	124	PRM18POLY.....	610	PRMSD1585.....	532
PF62150.....	565	PF64122.....	568	PJA30354.....	123	PRM34SEAL.....	610	PRMSD178.....	532
PF62152.....	565	PF64123.....	568	PJA30598.....	123	PRM6C.....	533	PRMSD1785.....	532
PF62154.....	565	PF64124.....	568	PJA31037.....	123	PRM6DUP.....	534	PRMSD238.....	532
PF62156.....	565	PF64232.....	568	PJA31038.....	123	PRM6HGBX.....	534	PRMSD2258.....	532
PF62160.....	565	PF64234.....	568	PJA3649.....	123	PRM7165.....	531	PRMST34020.....	610
PF62168.....	565	PF64236.....	568	PJA3651.....	123	PRM8C.....	533	PRMSWG9100.....	396
PF62172.....	565	PF64238.....	568	PJA3655.....	123	PRM8CTDSKR.....	534	PRMTH1585.....	531
PF62174.....	565	PF64304.....	570	PJA3659.....	123	PRM8DUP.....	534	PRMTH2145.....	531
PF62176.....	566	PF64501.....	569	PJA3666.....	123	PRM8HGC.....	533	PRMTHDZ2145.....	532
PF62178.....	566	PF64502.....	569	PJA3685.....	124	PRMCS114.....	531	PTC9748.....	92
PF62202.....	565	PF64505.....	570	PJA3686.....	124	PRMCS1145.....	531	PU1200.....	612
PF62207.....	565	PF66004.....	569	PJA6255.....	123	PRMCS118.....	531	PU1500.....	612
PF62208.....	565	PF66005.....	569	PK01RW.....	606	PRMCS158.....	531	PU1600.....	612
PF62209.....	565	PF66006.....	569	PK06BJ.....	606	PRMCS1585.....	531	PU1820C.....	432
PF62210.....	565	PF66009.....	569	PK10-58050.....	606	PRMCS212.....	531	PU1900C.....	431
PF62222.....	566	PF66019.....	569	PK10-58100.....	606	PRMCS2125.....	531	PU1904.....	431
PF62228.....	566	PF67339.....	567	PK528.....	606	PRMCS300.....	531	PU1930C.....	432
PF62229.....	566	PF67343.....	567	PK572TFR.....	606	PRMCS3005.....	531	PU2000C.....	432
PF62250.....	565	PF67359.....	567	PKE41-20.....	76	PRMCS6200.....	531	PU2204.....	432
PF62252.....	565	PF67363.....	567	PKE41-21.....	76	PRMCS62005.....	531	PU2250.....	432
PF62254.....	565	PF69003.....	561	PKE41-22.....	76	PRMEL3.....	533	PU2304.....	431
PF62266.....	565	PF69004.....	561	PKE92-21.....	77	PRMELD22.....	533	PU2340B.....	431
PF62268.....	565	PF69012.....	561	PKE92-22.....	77	PRMFS114.....	531	PU2400B.....	432
PF62270.....	565	PF69017.....	561	PKEKIT#109.....	77	PRMFS1145.....	531	PU2404.....	432
PF62272.....	565	PF69026.....	571	PO212C.....	596	PRMFS118.....	531	PU2430C.....	432
PF62274.....	565	PF69027.....	571	PO406C.....	596	PRMFS158.....	531	PU2600CS.....	432

Spokane, WA 509-535-9841

Billings, MT 406-248-7196



PU700.....	432	RABX1022000.....	530	RABX8040957.....	522	RAE50.....	506	RASWW-1432.....	511
PU9450R A.L.S.....	433	RABX1070000.....	529	RABX8041957.....	522	RAE55.....	507	RASWW-3826.....	511
QC2200.....	212	RABX1071000.....	529	RABX8042957.....	522	RAEPOL6.....	543	RASWW-3830.....	511
QC2201.....	213	RABX1072000.....	529	RABX8043957.....	522	RAFPP012S.....	543	RASWW-3836.....	511
QC2500.....	213	RABX1074000.....	529	RABX8044957.....	522	RAFPP034B.....	543	RASWW-5850.....	511
QC2501.....	213	RABX1075000.....	529	RABX8045957.....	522	RAFPP100.....	543	RAT3012.....	542
QC2504.....	213	RABX1088000.....	529	RABX8046957.....	522	RAFPP112T.....	543	RAT3034B.....	542
QC2601.....	213	RABX1107053.....	527	RABX8047957.....	523	RAG5-22.....	507	RAT3034S.....	542
QDBIT3S-RC10.....	555	RABX1109053.....	527	RABX8048957.....	523	RAHN-1405.....	513	RAT3100.....	542
QDBIT3SU-RC10.....	555	RABX1120000.....	528	RABX8050957.....	523	RAHN-5860.....	513	RAT3FUEL.....	542
QDPROCCS+M25K.....	554	RABX1123000.....	528	RABX8051957.....	523	RAHW3-114.....	514	RAT3MAG.....	542
QDSS3DSC3BS.....	554	RABX1134000.....	528	RABX8052957.....	523	RAHW3-134.....	514	RAT3SS.....	542
QDWSNTL134S.....	555	RABX1136000.....	528	RABX8053957.....	523	RAHW3-214.....	514	RATEK034.....	543
QDWSNTL212S.....	555	RABX1140000.....	528	RABX8054957.....	523	RAHW3-234.....	514	RATF1100.....	543
QDWSNTL2LS.....	555	RABX1143000.....	528	RABX8055957.....	523	RAHW3-314.....	514	RATFUEL.....	544
QDWSNTLG212S.....	554	RABX1146000.....	528	RABX8056957.....	523	RAHW4-114.....	514	RATSHMP034.....	547
QDWSNTLG3s.....	554	RABX1147000.....	528	RABX8057957.....	523	RAHW4-134.....	514	RATVP0L612.....	547
RA10HSSS10.....	546	RABX1149000.....	528	RABX8058957.....	525	RAHW4-214.....	514	RAVIPER.....	544
RA12HSSS10.....	546	RABX1150000.....	528	RABX8059957.....	525	RAHW4-234.....	514	RAWS-100120.....	509
RA14STUD.....	546	RABX1152000.....	528	RABX8060925.....	525	RAHW4-314.....	514	RAWS-10060.....	509
RA14TRHMP034.....	546	RABX1155000.....	528	RABX8061957.....	525	RAHX-1222.....	513	RAWS-10090.....	509
RA14TRHSS10.....	546	RABX1157000.....	528	RABX8062957.....	525	RAHX-3822.....	513	RAWS-1226.....	509
RA1503K.....	545	RABX1160000.....	530	RABX8063925.....	526	R-AIPDS185S.....	347	RAWS-1236.....	509
RA1506.....	545	RABX1196200.....	527	RABX8064925.....	526	RAM012.....	542	RAWS-1242.....	509
RA1508.....	545	RABX1199200.....	527	RABX8069925.....	521	RAM034.....	542	RAWS-1244.....	509
RA1508SD.....	545	RABX1200200.....	527	RABX8073925.....	521	RAM034BB.....	542	RAWS-1254.....	509
RA1510.....	545	RABX1202200.....	527	RABX8077925.....	522	RAM100.....	542	RAWS-1270.....	509
RA1510SD.....	545	RABX1204200.....	527	RABX8078925.....	522	RAM100BB.....	545	RAWS-1416.....	509
RA1512.....	545	RABX1208200.....	527	RABX8080925.....	523	RAMP034TH.....	542	RAWS-1422.....	509
RA1512SD.....	545	RABX1210200.....	527	RABX8113910.....	525	RAPF-234.....	514	RAWS-1432.....	509
RA1514.....	545	RABX1213200.....	527	RABX8114910.....	525	RAPF3-114.....	514	RAWS-34100.....	509
RA1514SD.....	545	RABX1218200.....	527	RABX8121910.....	525	RAPF3-134.....	514	RAWS-34120.....	509
RA1516.....	545	RABX1304000.....	528	RABX8122910.....	525	RAPF3-214.....	514	RAWS-3440.....	509
RA1516SDC.....	545	RABX1308000.....	530	RABX8123910.....	525	RAPF3-314.....	514	RAWS-3446.....	509
RA1516SDE.....	544	RABX1332000.....	530	RABX8124910.....	525	RAPF4-114.....	514	RAWS-3454.....	509
RA1524.....	545	RABX1333000.....	530	RABX8125910.....	525	RAPF4-134.....	514	RAWS-3462.....	509
RA1524SDC.....	545	RABX1399053.....	527	RABX8126910.....	525	RAPF4-214.....	514	RAWS-3470.....	509
RA1524SDE.....	544	RABX1404000.....	530	RABX8127910.....	525	RAPF4-234.....	514	RAWS-3484.....	509
RA1623WK.....	545	RABX1414000.....	529	RABX8128910.....	525	RAPF4-314.....	514	RAWS-3822.....	509
RA1643W.....	545	RABX1415000.....	530	RABX8129910.....	525	RAPLY138.....	543	RAWS-3826.....	509
RA1906.....	545	RABX1416000.....	530	RABX8137957.....	523	RAPTSEMI6.....	547	RAWS-3830.....	509
RA1908.....	545	RABX1429000.....	530	RABX8139957.....	522	RAPTSEMI8.....	547	RAWS-3836.....	509
RA22CW.....	547	RABX1431000.....	529	RABX8141957.....	522	RAR-FUEL.....	542	RAWS-3850.....	509
RA2D60.....	547	RABX1432000.....	530	RABX8145925.....	525	RARH7020.....	507	RAWS-3870.....	509
RA32CW.....	547	RABX1527200.....	527	RABX8150922.....	524	RARL-12.....	512	RAWS-58100.....	509
RA34HSSS10.....	546	RABX1553000.....	528	RABX8152910.....	525	RARL-14.....	512	RAWS-5834.....	509
RA38HSMPO34.....	546	RABX1554000.....	528	RABX8153922.....	524	RARL-34.....	512	RAWS-5842.....	509
RA38HSSS10.....	546	RABX1555000.....	530	RABX8181922.....	524	RARL-38.....	512	RAWS-5850.....	509
RA38TRHMP034.....	546	RABX1563200.....	527	RABX8194910.....	525	RARL-58.....	512	RAWS-5860.....	509
RA3D60.....	547	RABX1586000.....	528	RABX8268957.....	523	RARM-12.....	511	RAWS-5870.....	509
RA3RS25.....	547	RABX1587000.....	528	RABX8269957.....	522	RARM-14.....	511	RAWS-5884.....	509
RA3RS27.....	547	RABX1590000.....	529	RABX8269957.....	526	RARM-38.....	511	RAWS-78100.....	509
RA42CW.....	547	RABX1619000.....	530	RABX8270957.....	523	RART-112.....	512	RAWS-7860.....	509
RA4D60.....	547	RABX1641000.....	529	RABX8271957.....	524	RART-114.....	512	RAWS-7880.....	509
RA4RS25.....	547	RABX1647000.....	530	RABX8272957.....	524	RART-134.....	512	RAWW-10090.....	510
RA4RS27.....	547	RABX5003957.....	521	RABX8273910.....	525	RART-138.....	512	RAWW-1226.....	510
RA5RS25.....	547	RABX8002957.....	521	RABX8293957.....	524	RART-158.....	512	RAWW-1236.....	510
RA5RS27.....	547	RABX8004957.....	521	RABX8294922.....	524	RARTX-138.....	512	RAWW-1242.....	510
RA6RS27.....	547	RABX8007957.....	521	RABX8295922.....	524	RARX-12.....	512	RAWW-1254.....	510
RA9190.....	545	RABX8008925.....	521	RABX8303957.....	522	RARX-38.....	512	RAWW-1270.....	510
RAA101.....	506	RABX8008957.....	521	RABX8303957.....	526	RASA270.....	544	RAWW-1416.....	510
RAA102.....	506	RABX8009925.....	521	RAC6-18.....	506	RASDC-125C.....	546	RAWW-1422.....	510
RAA-24.....	506	RABX8010957.....	521	RACWS-1236.....	508	RASFS-1430.....	513	RAWW-1432.....	510
RAA500-KIT.....	506	RABX8011925.....	521	RACWS-1244.....	508	RASFS-3826.....	513	RAWW-34100.....	510
RAA501.....	506	RABX8013925.....	521	RACWS-1254.....	508	RASFS-3840.....	513	RAWW-3446.....	510
RAA7-10.....	506	RABX8014925.....	521	RACWS-1270.....	508	RASHN-1230.....	513	RAWW-3454.....	510
RAA7-28.....	506	RABX8015925.....	521	RACWS-34100.....	508	RASP100.....	545	RAWW-3470.....	510
RAA7-5.....	506	RABX8019957.....	521	RACWS-3454.....	508	RASP112.....	545	RAWW-3822.....	510
RAA7-8.....	506	RABX8020957.....	521	RACWS-3462.....	508	RASP114.....	545	RAWW-3826.....	510
RABB-10.....	514	RABX8021957.....	521	RACWS-3470.....	508	RASP178.....	545	RAWW-3830.....	510
RABS1016000.....	530	RABX8022925.....	521	RACWS-3484.....	508	RASP34.....	544	RAWW-3836.....	510
RABX1000000.....	530	RABX8023925.....	521	RACWS-3830.....	508	RASP58.....	544	RAWW-3850.....	510
RABX1001000.....	530	RABX8024957.....	522	RACWS-3836.....	508	RASP58TH.....	545	RAWW-5834.....	510
RABX1002000.....	530	RABX8025957.....	522	RACWS-3850.....	508	RASRM-12.....	512	RAWW-5850.....	510
RABX1003000.....	530	RABX8026957.....	522	RACWS-5850.....	508	RASRM-14.....	512	RAWW-5860.....	510
RABX1004000.....	530	RABX8027957.....	522	RACWS-5860.....	508	RASRM-34.....	512	RAWW-5870.....	510
RABX1005000.....	530	RABX8030957.....	522	RACWS-5870.....	508	RASRM-38.....	512	RB1013.....	231
RABX1006000.....	529	RABX8031925.....	522	RACWS-5884.....	508	RASRM-58.....	512	RB1028.....	231
RABX1009000.....	530	RABX8033925.....	522	RAD60.....	544	RASRS-1420.....	513	RB1314.....	231
RABX1010000.....	530	RABX8034925.....	522	RAE101.....	506	RASSRM-12.....	511	RB1317.....	231
RABX1011000.....	530	RABX8035925.....	522	RAE102.....	507	RASWW-1226.....	511	RB2005.....	613
RABX1014000.....	530	RABX8036925.....	522	RAE200.....	506	RASWW-1236.....	511	RB2631.....	612
RABX1019000.....	530	RABX8037957.....	522	RAE202.....	507	RASWW-1242.....	511	RB2632.....	612
RABX1020000.....	530	RABX8038957.....	522	RAE24.....	506	RASWW-1254.....	511	RB3154-06.....	237
RABX1021000.....	530	RABX8039957.....	522	RAE300.....	506	RASWW-1422.....	511	RB4401-00.....	231



Part Number Index

www.edgecs.com

RB4500	231	RDVK3CK1EXT	153	RI31010	126	RI32840	129	RI36895	136
RB4520	231	RDVK3CK1HW	153	RI31015	126	RI32850	129	RI36900	136
RB6385	613	RDVK3CK1ROD	153	RI31020	126	RI32870	129	RI36912	137
RB7802-00	237	RDVK3CK1WHL	153	RI31025	126	RI32880	129	RI36962	143
RB7804-00	237	RDVK916PENT	153	RI31028	144	RI32895	130	RI37375	136
RB9C03	613	RDVKA	153	RI31030	126	RI32900	130	RI37380	136
RB9T55	230	RDVKA45	153	RI31035	126	RI32903	146	RI37385	136
RD1-2PVC	150	RDVKEXT	153	RI31040	126	RI32910	133	RI37390	136
RD2RBHD	150	RDVKKIT	153	RI31045	126	RI32915	133	RI37395	136
RD2RBS	150	RDVKVW	154	RI31065	126	RI32920	133	RI37400	136
RD30-40	150	RDVW0	154	RI31075	126	RI32925	133	RI37405	136
RD30-40P	150	RDVW10	154	RI31080	126	RI32930	133	RI37410	136
RD345T	150	RDVW1	154	RI31090	126	RI32935	133	RI37415	136
RD3-6PVC	150	RDVW2	154	RI31095	126	RI32950	133	RI37480	136
RD3RG	150	RDVW3	154	RI31100	126	RI32975	133	RI37485	136
RD450+	151	RDVWALP1	154	RI31105	126	RI32985	133	RI37490	136
RD680PVC	150	RDVWALP2	154	RI31110	126	RI33005	134	RI37495	136
RDDEB0	151	RE01G-OP	97	RI31115	126	RI33055	133	RI37500	136
RDDEB3	151	RE05G-RS	97	RI31118	145	RI33057	140	RI37505	136
RDDEB38	151	RE15-SK	97	RI31120	126	RI33100	131	RI37570	136
RDEHTP500	151	RE16A9	96	RI31125	126	RI33105	131	RI37610	136
RDEHTP500C	151	RE16RT	96	RI31128	145	RI33110	131	RI37615	136
RDFPV20	151	RE1A9	96	RI31130	126	RI33115	131	RI37620	136
RDH12L	151	RE1RT	96	RI31133	145	RI33120	131	RI37625	136
RDH12S	151	RE4A9	96	RI31175	128	RI33125	131	RI37630	136
RDH12X	151	RE4RT	96	RI31180	128	RI33130	131	RI37635	136
RDH12XX	151	REGRT-K5	96	RI31305	126	RI33145	131	RI37640	136
RDH21/2L	151	RERB-10	96	RI31310	127	RI33150	131	RI37645	136
RDH21/2S	151	RERB-12	96	RI31315	127	RI33155	131	RI37650	136
RDH21/2X	151	RERB-14	96	RI31320	127	RI33160	131	RI37655	136
RDH4L	151	RERB-16	96	RI31325	127	RI33165	131	RI37842	147
RDH4S	151	RERB-18	96	RI31330	127	RI33170	131	RI37847	147
RDH4X	151	RERB-20	96	RI31340	127	RI33175	131	RI38100	136
RDH6L	151	RERB-22	96	RI31345	127	RI33180	131	RI38120	137
RDH6S	151	RERB-24	96	RI31350	127	RI33185	131	RI38155	137
RDH6X	151	RERB-32	96	RI31355	127	RI33190	131	RI38220	136
RDH8L	151	RERB-6	96	RI31360	127	RI33195	131	RI38225	136
RDH8S	151	RERB-8	96	RI31365	127	RI33200	131	RI38235	136
RDH8X	151	RERB-9	96	RI31385	126	RI33205	131	RI38540	135
RDH8XX	151	RH56642	336	RI31400	127	RI33220	131	RI40085	128
RDHS4	150	RH56671	336	RI31405	127	RI33225	131	RI40130	129
RDHTP1000	152	RH56672	336	RI31555	128	RI34945	132	RI40185	129
RDHTP300	152	RH56673	336	RI31570	128	RI34950	132	RI40195	129
RDHWVK	153	RH56674	336	RI31580	128	RI34955	132	RI40205	129
RDMH26	152	RH57160	336	RI31585	128	RI34960	132	RI40210	129
RDMH30	152	RH57162	336	RI31595	128	RI34965	135	RI40215	129
RDMH36	152	RH57164	336	RI31605	128	RI35155	135	RI40220	129
RDO	150	RHDTT2436	336	RI31610	128	RI35245	143	RI40617	133
RDOSS	150	RHDTT3660	336	RI31615	128	RI35255	143	RI41315	143
RDPE51CTS	152	RHUD18C	337	RI31622	133	RI35265	143	RI41320	143
RDPE51IPS	152	RHUD33D	337	RI31627	133	RI35275	143	RI41330	143
RDPE52-2CTS	152	RHUD33S	337	RI31630	128	RI35280	143	RI41335	143
RDPE52-2IPS	152	RHUD3B	337	RI31632	134	RI35585	142	RI41575	137
RDPE52CTS	152	RI10883	137	RI31635	128	RI35600	132	RI41590	137
RDPE52IPS	152	RI14988	128	RI31637	134	RI35605	132	RI41600	137
RDPE52PC160	152	RI15682	138	RI31642	134	RI35610	132	RI41610	137
RDPE54	152	RI15722	138	RI31647	134	RI35615	132	RI41697	148
RDPE58H	152	RI16703	129	RI31652	134	RI35620	132	RI41855	138
RDPE58M	152	RI16953	144	RI31655	128	RI35625	132	RI41935	137
RDR1032/S	150	RI20483	145	RI31657	134	RI35630	132	RI42002	148
RDTC1SL	150	RI21893	146	RI31660	128	RI35635	132	RI42250	135
RDTC1SLR	150	RI22088	137	RI31662	134	RI35685	132	RI42260	135
RDTC50SL	150	RI23488	134	RI31665	128	RI35815	130	RI42265	135
RDTC50SLR	150	RI23493	134	RI31668	86	RI35820	130	RI42270	135
RDTC72SLR	150	RI25588	134	RI31670	128	RI35825	130	RI42275	135
RDTC75SL	150	RI25638	141	RI31675	128	RI35830	130	RI42280	135
RDUPBEVEL	154	RI26092	140	RI31680	128	RI35835	130	RI42360	138
RDUPC616A	152	RI26132	140	RI31685	128	RI35840	130	RI42365	138
RDUPC636A	152	RI26152	140	RI31695	128	RI35845	130	RI42370	138
RDUPC648A	152	RI26192	140	RI31700	128	RI35850	130	RI42600	137
RDUPCARB4	154	RI26663	145	RI31705	128	RI35855	130	RI42620	137
RDUPCARB6	154	RI26668	145	RI31710	128	RI36097	143	RI42625	137
RDUPCSTEEL4	154	RI26803	134	RI31720	128	RI36122	143	RI42950	137
RDUPCSTEEL6	154	RI27642	149	RI31725	128	RI36132	143	RI43507	149
RDUPDIA4C	154	RI27913	145	RI31730	128	RI36355	135	RI43512	149
RDUPDIA6C	154	RI27923	145	RI31735	128	RI36475	135	RI44185	131
RDVK10	153	RI27938	144	RI31745	128	RI36565	136	RI44190	131
RDVK10-3CK1CK2	153	RI28043	145	RI31750	128	RI36592	134	RI44852	143
RDVK10-3CK1EXT	153	RI30063	145	RI31760	128	RI36597	134	RI45007	141
RDVK2CK1	153	RI30068	145	RI31765	128	RI36620	136	RI46907	149
RDVK2CK2	153	RI30088	135	RI31775	128	RI36630	136	RI47057	126
RDVK2COMBO	153	RI30093	135	RI31790	128	RI36875	136	RI47740	140
RDVK3CK1-2HL	153	RI30118	135	RI32820	129	RI36880	136	RI47745	140
RDVK3CK1CK2	153	RI31000	126	RI32825	129	RI36885	136	RI47750	140
RDVK3CK1COMBO	153	RI31005	126	RI32830	129	RI36890	136	RI47755	140

Spokane, WA 509-535-9841

Billings, MT 406-248-7196

Yakima, WA 509-248-1144

Gillette, WY 307-682-8522



RI47760	140	RI96497	139	RL08294	518	RL2726SD	517	RL6208	519
RI47765	140	RI97065	138	RL08296	518	RL2728SD	517	RL6401SD	516
RI47770	140	RI97075	138	RL08298	518	RL2730SD	517	RL6403SD	516
RI47780	140	RI97787	133	RL08484	517	RL2732SD	517	RL6404SD	516
RI47785	140	RKRS-1	244	RL08495	517	RL2734SD	517	RL6407SD	516
RI47790	140	RKRS-3	244	RL08497SD	518	RL2736SD	517	RL7020	93
RI48225	141	RKSRS-4	244	RL0950	95	RL2740SD	517	RL7021	93
RI48235	141	RL0302	93	RL0951	95	RL2742SD	517	RL7031	93
RI48245	141	RL0304	93	RL0952	95	RL2744SD	517	RL7033	93
RI48250	141	RL0306	93	RL0953	95	RL2746SD	517	RL7035	93
RI48255	141	RL0308	93	RL0954	95	RL2748SD	517	RL7036	93
RI48260	141	RL0310	93	RL0955	95	RL2750SD	517	RL7043	93
RI48270	141	RL0312	93	RL0959	95	RL2752SD	517	RL7045	93
RI48297	141	RL0314	93	RL0960	95	RL2760SD	517	RL7049	93
RI50767	133	RL0320	93	RL0965	95	RL2762SD	517	RL7051	93
RI50812	133	RL0321	93	RL0966	95	RL2764SD	517	RL7057	93
RI50985	141	RL0322	93	RL0967	95	RL2766SD	517	RL7059	93
RI51005	141	RL0323	93	RL0968	95	RL2768SD	517	RL7064	93
RI53117	147	RL0324	93	RL0969	96	RL2770SD	517	RL7066	93
RI57592	142	RL0325	93	RL0970	96	RL2772SD	517	RL7072	93
RI58007	139	RL0327	93	RL0974	95	RL2774SD	517	RL7077	93
RI58960	149	RL0329	93	RL0975	95	RL2776SD	517	RL7094	92
RI59205	147	RL0331	93	RL0982	95	RL2781	517	RL7095	92
RI59225	147	RL0333	93	RL0983	95	RL2782	517	RL7180SD	516
RI59295	147	RL0334	93	RL1312	516	RL2783	517	RL7181SD	516
RI59470	147	RL0336	93	RL1314	516	RL2785	517	RL7182SD	516
RI59787	146	RL0338	93	RL1316	516	RL2786	517	RL7198SD	516
RI60052	148	RL0339	93	RL1318	516	RL2787	517	RL7204SD	515
RI61122	139	RL0341	93	RL1320	516	RL2788	517	RL7206SD	515
RI61142	139	RL0343	93	RL1322	516	RL2789	517	RL7208SD	515
RI62225	147	RL0346	93	RL1324	516	RL2793	517	RL7210SD	515
RI62235	147	RL0348	93	RL1326	516	RL2794	517	RL7220SD	515
RI62245	147	RL0349	93	RL1328	516	RL2796	517	RL7222SD	515
RI62250	147	RL0351	93	RL1330	516	RL2797	517	RL7224SD	515
RI62260	147	RL0352	93	RL1344	516	RL2802	519	RL7226SD	515
RI62270	147	RL0354	93	RL1348	516	RL2803	519	RL7228SD	515
RI62275	149	RL0355	93	RL1356	516	RL2804	519	RL7230SD	515
RI62280	149	RL0359	93	RL1358	516	RL2806	519	RL7240SD	515
RI62597	148	RL0361	93	RL1402	94	RL2808	519	RL7242SD	515
RI62747	144	RL0362	93	RL1403	94	RL2814	519	RL7244SD	515
RI62860	149	RL0364	93	RL1407	94	RL2820	519	RL7246SD	515
RI62862	143	RL0365	93	RL1409	94	RL2826	519	RL7248SD	515
RI62930	149	RL0368	93	RL1410	94	RL2839	518	RL7250SD	515
RI62990	147	RL0370	93	RL1412	94	RL2840	518	RL7252SD	515
RI63005	147	RL0371	93	RL1413	94	RL2842	518	RL7260SD	515
RI63065	147	RL0375	93	RL1420	94	RL2844	518	RL7262SD	515
RI64977	142	RL0376	93	RL1421	94	RL2846	518	RL7264SD	515
RI66492	149	RL0377	93	RL1433	94	RL2848	518	RL7266SD	515
RI66497	149	RL0379	93	RL1434	94	RL2850	518	RL7268SD	515
RI66512	149	RL0380	93	RL1436	94	RL2939	518	RL7270SD	515
RI66807	128	RL0381	93	RL1443	94	RL2940	518	RL7280SD	515
RI66987	142	RL0382	93	RL1444	94	RL2942	518	RL7282SD	515
RI66992	142	RL0394	93	RL1446	94	RL2944	518	RL7284SD	515
RI66997	142	RL0396	93	RL1449	94	RL2946	518	RL7286SD	515
RI67182	140	RL0500SD	518	RL1450	94	RL2948	518	RL7288SD	515
RI67872	139	RL0501	94	RL1457	94	RL3272	520	RL7290SD	515
RI68057	146	RL0502SD	518	RL1458	94	RL3302	520	RL7400SD1	515
RI68650	130	RL0503	94	RL1464	94	RL3332	520	RL7402SD1	515
RI68815	138	RL0504	94	RL1465	94	RL3362	520	RL7404SD1	515
RI68967	144	RL0505	94	RL1470	94	RL3392	520	RL7410SD1	515
RI69982	130	RL0512	94	RL1477	94	RL3631	520	RL7412SD1	515
RI70830	137	RL0513	94	RL1490	94	RL3691	520	RL7413SD1	515
RI70835	137	RL0514	94	RL2345	521	RL3755	519	RL7413SD2	514
RI71722	146	RL0519	94	RL2346Z	521	RL3756	519	RL7414SD1	515
RI72037	129	RL0522	94	RL2348	520	RL3758	519	RL7414SD2	514
RI73370	142	RL0523	94	RL2349	521	RL3759	519	RL7415SD1	515
RI74012	137	RL0531	94	RL2433	519	RL3760	519	RL7415SD2	514
RI74047	137	RL0538	94	RL2513	519	RL3794	519	RL7416SD1	515
RI74207	130	RL0545	94	RL2523	519	RL3795	519	RL7416SD2	514
RI74720	131	RL0547	94	RL2542	519	RL4054	520	RL7417SD1	515
RI74730	131	RL08280	518	RL2543	519	RL4056	520	RL7420SD1	515
RI76767	137	RL08281	516	RL2562	519	RL4131	520	RL7422SD1	515
RI76777	142	RL08281	518	RL2563	519	RL4141	520	RL7422SD2	514
RI80475	142	RL08282	518	RL2573	519	RL4231	520	RL7423SD2	514
RI83037	143	RL08283	518	RL2583	519	RL4241	520	RL7424SD1	515
RI83292	148	RL08284	518	RL2700SD	517	RL4441	520	RL7424SD2	514
RI83295	134	RL08285	518	RL2702SD	517	RL5522	520	RL7426SD1	515
RI84532	139	RL08286	518	RL2704SD	517	RL5523	520	RL7426SD2	514
RI84537	139	RL08287	518	RL2706SD	517	RL5524	520	RL7427SD1	515
RI87582	147	RL08288	518	RL2708SD	517	RL5526	520	RL7427SD2	514
RI90107	126	RL08289	518	RL2710SD	517	RL5528	520	RL7428SD1	515
RI91142	138	RL08290	518	RL2712SD	517	RL5530	520	RL7430SD1	515
RI92462	138	RL08291	518	RL2720SD	517	RL5531	520	RL7432SD1	515
RI92467	138	RL08293	516	RL2722SD	517	RL5532	520	RL7433SD1	515
RI93492	132	RL08294	516	RL2724SD	517	RL6206	519	RL7433SD2	514



RL7434SD1.....	515	RO15226X.....	155	SB06300.....	422	SLHD5860.....	68	SNHELI37900.....	505
RL7434SD2.....	514	RO15227X.....	155	SB06400.....	422	SLHD77.....	68	SNHELITOO37A.....	505
RL7435SD2.....	514	RO15251X.....	155	SB06500.....	422	SLHD77M.....	68	SNMASA.....	550
RL7436SD1.....	515	RO15252X.....	155	SB25100.....	413	SMTHD37600H.....	501	SNMASAP.....	550
RL7436SD2.....	514	RO15253X.....	155	SB25245.....	413	SNADT30.....	497	SNMMBD3762.....	505
RL7438SD1.....	515	RO15254X.....	155	SB25360.....	413	SNADT30CKT.....	497	SNSET1.7KTA.....	496
RL7438SD2.....	514	RO15255X.....	155	SB33610.....	413	SNADT30P.....	497	SNSET22.....	496
RL7439SD1.....	515	RO15256X.....	155	SB33712.....	413	SNADT813B.....	497	SNSET56.....	496
RL7440SD1.....	515	RO16201.....	155	SB37416.....	413	SNAMN813-RP5.....	498	SNSET-PAC-EZ.....	496
RL7441SD1.....	515	RO16202.....	155	SB37424.....	413	SNARC100A-RP25.....	498	SNSET-XP22.....	496
RL7442SD1.....	515	RO56051.....	154	SB37448.....	413	SNARC100-RP25.....	498	SNSET-XP56.....	496
RL7442SD2.....	514	RO63005.....	154	SB37459.....	413	SNARC125A-RP25.....	498	SNSH15.....	610
RL7444SD1.....	515	RO69635NT.....	155	SB37472.....	413	SNARC125-RP25.....	498	SNSH20.....	610
RL7444SD2.....	514	RSA315-L.....	618	SB37478.....	413	SNARC37A-RP25.....	498	SNSH30.....	610
RL7446SD1.....	515	RSA315-M.....	618	SB37496.....	413	SNARC37-RP25.....	498	SNSH9.....	610
RL7446SD2.....	514	RSA315-XL.....	618	SB37524.....	413	SNARC50A-RP25.....	498	SNSL25200PF.....	502
RL7448SD1.....	515	RU2700XL.....	92	SB37532.....	413	SNARC50-RP25.....	498	SNSL25200R.....	502
RL7448SD2.....	514	RU2875XL.....	92	SB37924.....	413	SNARC62A-RP25.....	498	SNSL25214A.....	502
RL7449SD1.....	515	RU2950.....	92	SB37948.....	413	SNARC62-RP25.....	498	SNSL25300PF.....	502
RL7450SD1.....	515	RU4004.....	92	SB38532.....	413	SNARC75A-RP25.....	498	SNSL31212H.....	502
RL7451SD1.....	515	RU4008.....	92	SB38624.....	413	SNARC75-RP25.....	498	SNSL31312PF.....	502
RL7452SD1.....	515	RVSJ21-3ZGS-2X.....	327	SB38632.....	413	SNARC87A-RP25.....	498	SNSL37212R.....	502
RL7454SD1.....	515	RVSJ21-3ZGS-3X.....	327	SB38648.....	413	SNARC87-RP25.....	498	SNSL37234PF.....	502
RL7461SD1.....	515	RVSJ21-3ZGS-L.....	327	SB38678.....	413	SNAT08.....	497	SNSL37300H.....	502
RL7463SD1.....	515	RVSJ21-3ZGS-XL.....	327	SFA2436.....	597	SNAT10.....	497	SNSL37400H.....	502
RL7465SD1.....	515	RVSJ41-3ZGS-2X.....	327	SFAP1.....	598	SNAT13.....	497	SNSL37400PF.....	502
RL7473SD1.....	515	RVSJ41-3ZGS-3X.....	327	SFAP4.....	598	SNAT30.....	497	SNSL37600PF.....	502
RL7475SD1.....	515	RVSJ41-3ZGS-L.....	327	SFAP6.....	598	SNATPAC05KT.....	497	SNSL50300H.....	502
RL7559.....	521	RVSJ41-3ZGS-XL.....	327	SFAPH.....	598	SNAT-XP13.....	497	SNSL50400H.....	502
RL7569.....	521	RVSJ22-2ZGM-L.....	326	SFBLD38100.....	398	SNAT-XP30.....	497	SNSL50600H.....	502
RL7579.....	521	RVSJ22-2ZGM-XL.....	326	SFBLD38100.....	599	SNBBMD2550.....	505	SNSL62414H.....	502
RL7589.....	521	RVSV6G-2XL.....	327	SFBT2180.....	599	SNBBMD6275.....	505	SNSL62600H.....	502
RL8478SD.....	516	RVSV6G-L.....	327	SFCM2436.....	598	SNBBRD2550.....	505	SNSL75414H.....	502
RL8480SD.....	516	RVSV6G-M.....	327	SFCM2436BLUE.....	598	SNBBWF2550.....	505	SNSL75614H.....	502
RL8486SD.....	516	RVSV6G-XL.....	327	SFCM3636.....	598	SNBBWF3762.....	505	SNSTB1001000.....	500
RL8490SD.....	516	RVSV70-2XL.....	327	SFCM3636BLUE.....	598	SNBBWF6275.....	505	SNSTB1001300.....	500
RL8801.....	94	RVSV70-L.....	327	SFCS24200W.....	597	SNCDT10.....	495	SNSTB100700.....	500
RL8802.....	94	RVSV70-XL.....	327	SFCS36200W.....	597	SNDA25.....	503	SNSTB2-37234.....	500
RL8809.....	94	RVSVS63G-2XL.....	327	SFCS36500.....	597	SNDA37.....	503	SNSTB2-372346SS.....	500
RL8810.....	94	RVSVS63G-L.....	327	SFCS24810.....	602	SNDA37S.....	503	SNSTB2-37300.....	500
RL8812.....	94	RVSVS63G-XL.....	327	SFDC24200.....	158	SNDA37SS.....	503	SNSTB2-373006SS.....	500
RL8817.....	94	RY2AA-B RB.....	430	SFDC24200.....	599	SNDA50.....	503	SNSTB2-37312.....	500
RL8818.....	94	RY2D-B RB.....	430	SFDC36200.....	158	SNDA50C.....	504	SNSTB2-37334.....	500
RL8820.....	94	RY6V-HDM.....	431	SFDC36200.....	599	SNDA50S.....	503	SNSTB2-373346SS.....	500
RL8829.....	94	RYAL-9V.....	431	SFDC48200.....	158	SNDA50SS.....	503	SNSTB2-37500.....	500
RL8830.....	94	RYAL-AA.....	431	SFDC48200.....	599	SNDA62.....	503	SNSTB2-375006SS.....	500
RL8833.....	94	RYAL-AAA.....	431	SFDG30W.....	598	SNDA75.....	503	SNSTB2-376126SS.....	500
RL8834.....	94	RYAL-C.....	431	SFDGRC.....	598	SNDA75C.....	504	SNSTB2-37700.....	500
RL8836.....	94	RYAL-D.....	431	SFFS24200.....	597	SNDA75C.....	504	SNSTB2-377006SS.....	500
RL8843.....	94	RYI6V-B2.....	430	SFGRN066.....	601	SNDA75C.....	503	SNSTB2-50100.....	500
RL8844.....	94	RYILJ2AA-B.....	430	SFGRY066.....	601	SNDA75C.....	504	SNSTB2-50334.....	500
RL8846.....	94	RYIN2.....	430	SFKP35166.....	597	SNDA75C.....	503	SNSTB2-50414.....	500
RL8847.....	94	RYIN2-KML.....	430	SFORA66.....	601	SNDA75C.....	504	SNSTB2-50512.....	500
RL8848.....	94	RYIN2-MS.....	430	SFPC3042.....	598	SNDA75C.....	504	SNSTB2-50700.....	500
RL8853.....	94	RYISL2D-B.....	431	SFPC3648.....	598	SNDA75C.....	504	SNSTB2-50812.....	500
RL8859.....	94	RYIV2DM.....	430	SFPC3648.....	598	SNDA75C.....	504	SNSTB2-50812.....	500
RM3/4X18R.....	399	RYK13-2.....	431	SFPS3250.....	598	SNEDT22AP.....	495	SNSTB2-62100.....	500
RM3/4X18R.....	610	RYK3-2.....	431	SFRFD066.....	601	SNEDT22B.....	495	SNSTB2-62412.....	500
RM3/4X24R.....	399	RYR2AA-BA.....	430	SFSC300.....	598	SNEDT22CKT.....	495	SNSTB2-62500.....	500
RM3/4X24R.....	610	RYR2D.....	430	SFSC300WR.....	598	SNEDT22S.....	495	SNSTB2-62600.....	500
RM3/4X30R.....	399	RYR3D.....	430	SFWHI066.....	601	SNEDT22S.....	495	SNSTB2-62700.....	500
RM3/4X30R.....	610	RYRNC3AA-B.....	431	SFWS36300.....	598	SNEMN37B.....	498	SNSTB2-62812.....	500
RM3/4X36R.....	399	RYRNHL3AAA-B.....	437	SFWS60300.....	598	SNEMN50.....	498	SNSTB50100.....	500
RM3/4X36R.....	610	RYRNT3AAA-B.....	437	SFYEL066.....	601	SNENN2256.....	498	SNSTB50334.....	500
RM3/4X48R.....	399	RYSPHLTLED.....	431	SFZA02.....	598	SNETB10.....	499	SNSTB50414.....	500
RM3/4X48R.....	610	RZCR18L-1100.....	73	SH901-07-00.....	85	SNETB12.....	499	SNSTB50512.....	500
RM452000.....	614	RZCT125.....	74	SH901-15-7.....	85	SNETB4.....	499	SNSTB50700.....	500
RM452400.....	614	RZCT156.....	74	SH901-46-2.....	86	SNETB6.....	499	SNSTB50812.....	500
RNR5CC20100.....	596	RZCT250.....	74	SH903-04-7.....	85	SNETB8.....	499	SNSTB62100.....	500
RNR5CC20100FR.....	596	RZDR01-1100.....	74	SH903-04-7.....	85	SNETB8L.....	499	SNSTB62412.....	500
RNR5CC40100.....	596	RZFBR1.....	74	SH905-03-4.....	86	SNETIGV22.....	504	SNSTB62500.....	500
RNVAPOR BOND.....	397	RZGP8.....	74	SH905-66-1.....	86	SNETILV22.....	504	SNSTB62600.....	500
RNVAPOR BOND.....	597	RZRZ25.....	73	SH905-85-00.....	85	SNETS5010P.....	499	SNSTB62700.....	500
RNVAPOR BOOT.....	397	RZRZ4-GRK.....	74	SH906-49-5.....	86	SNETS506P.....	499	SNSTB62812.....	500
RNVB10.....	397	RZRZ4-GRK.....	74	SH906-72-62.....	86	SNETS6210P.....	499	SNSTB75100.....	500
RNVB10.....	596	RZSC4.....	74	SH906-72-62.....	86	SNETS6213P.....	499	SNSTB75512.....	500
RNVB15.....	397	RZTC1.....	74	SH906-86-7.....	86	SNETS626P.....	499	SNSTB75614.....	500
RNVB15.....	596	RZWD1.....	74	SH919-06-10.....	86	SNETS7513P.....	499	SNSTB75700.....	500
RO04510R.....	154	RZXB-DW10.....	74	SH919-07-10.....	86	SNETS7517P.....	499	SNSTB75812.....	500
RO14486.....	155	RZZB8.....	74	SH925-40.....	85	SNETS758P.....	499	SNTCAP370600.....	499
RO14487.....	155	RZZM3-1100.....	74	SH925-41.....	85	SNHELI371000.....	505	SNTCAP500834.....	499
RO15222X.....	155	SASWP.....	212	SH925-42.....	85	SNHELI371100.....	505	SNTCAP500912.....	499
RO15223X.....	155	SASWP3X.....	212	SH925-45.....	85	SNHELI371200.....	505	SNTCAP621112.....	499
RO15224X.....	155	SASWP6X.....	212	SH960-14-00.....	85	SNHELI37600.....	505	SNTCAP621212.....	499
RO15225X.....	155	SASWPGRA.....	212	SH960-97-10.....	85	SNHELI37700.....	505	SNTCAP751458.....	499
RO15226X.....	155	SASWPNORA.....	212	SLHD5510.....	67	SNHELI37800.....	505	SNTCAP751658.....	499



SNTHD25112RH 502	SO32-966 581	SOEJF12568 408	SR230010 320	STICD400K 577
SNTHD25134H 501	SO32-966PP 408	SOEJF1440 408	SR762000 320	STICD400M 577
SNTHD25214H 501	SO32-966PP 581	SOEJF144 408	SR772000 320	STICD400X 577
SNTHD25300H 501	SO32-967 408	SOEJF1454 408	SRB140074 321	STICD600 577
SNTHD37134H 501	SO32-967 581	SOEJF1456 408	SRB250000 320	STICD600K 577
SNTHD37212H 501	SO32-967PP 408	SOEJF14568 408	SRB260000 320	STICD600M 577
SNTHD37212RH 502	SO32-967PP 581	SOEJF3440 408	SRB270000 320	STICD600X 577
SNTHD37218RH 502	SO32-968 408	SOEJF3840 408	ST10-099 269	STICS1628 573
SNTHD37300H 501	SO32-968 581	SOEJF3854 408	ST10-209 269	STICS2436 573
SNTHD37400H 501	SO32-968PP 408	SOEJF3856 408	ST10-481 269	STICS3641 573
SNTHD37500H 501	SO32-969 408	SOEJF38568 408	ST10-499 269	STIES105 575
SNTHD37500HMG 501	SO32-969 581	SOKONDUCTOKURE 403	ST10-778 269	STIES120 575
SNTHD37600HMG 501	SO32-970 408	SOKURE200W-5 402	ST10-779 269	STIES129 575
SNTHD501200H 501	SO32-970 581	SOKURE200W-55 402	ST10-780 269	STIEZD22 575
SNTHD501300H 501	SO32-971 408	SOMASTIC-50 405	ST10-813M 269	STIEZD33FWS 576
SNTHD501400H 501	SO32-971 581	SOMASTIC-5 405	ST11-301T 270	STIEZD444MB 576
SNTHD501500H 501	SO35-913-1/10 406	SOMASTIC-548 405	ST11-700 270	STIEZD44 576
SNTHD50234RH 502	SO35-913 406	SOMASTIC-55 405	ST11-700A 270	STIEZDG444 576
SNTHD50300H 501	SO45-471 407	SOSEMI-MASTIC-42 405	ST11-700L 270	STIEZDP33FWS 576
SNTHD50400H 501	SO46-733 406	SOSEMI-MASTIC-460 405	ST11-718T 270	STIEZDP733GK 576
SNTHD50500H 501	SO50150022 407	SOSEMI-MASTIC-5 405	ST11-939 270	STIEZG1644 576
SNTHD50500HMG 501	SO50-990-1 408	SOSEMI-MASTIC-55 405	ST11-939A 270	STIEZG844 576
SNTHD50600H 501	SO51335577 400	SOT10-12 398	ST15-206 293	STIFS100 573
SNTHD50612H 501	SO51378645 402	SOT12-12 398	ST16-970 292	STIFS200 573
SNTHD50800H 501	SO51656862 402	SOT18-12 398	ST16-975 292	STIFS400 573
SNTHD62400H 501	SO51670854 403	SOT24-12 398	ST16-977 292	STIFSR100 574
SNTHD62500H 501	SO51677691 406	SOT36-12 398	ST16-978 292	STIFSR200 574
SNTHD62600H 501	SO51677744 406	SOT48-12 398	ST20-045 293	STIFSR400 574
SNTHD62612H 501	SO51678592 402	SOT8-12 398	ST20-065 293	STILCC150 573
SNTHD62800H 501	SO51679016 402	SOTThoroseal-10 405	ST20-556 292	STILCC200 573
SNTHD75100H 501	SO51679069 402	SOTThoroseal-30 405	ST28-100 270	STILCC300 573
SNTHD75100HMG 501	SO51681772 403	SOTThoroseal-50 405	ST28-139 269	STILCC400 573
SNTHD75182HMG 501	SO51703714 409	SOTThoroseal-60 405	ST28-140 269	STILCI300 575
SNTHD75400H 501	SO51703714 581	SQ015301-CH 333	ST28-141 269	STILCI305 575
SNTHD75500H 501	SO51703820 409	SQ015301-CH 620	ST28-142 269	STILCI320 575
SNTHD75700H 501	SO51703820 581	SQ015302-GR 333	ST28-500 270	STILCI329 575
SNTHD75812H 501	SO51704032 409	SQ015302-GR 620	ST28-510 270	STIRFG1 577
SNTHDT75600H 501	SO51704032 581	SQ015303-LA 333	ST30-456 417	STIRTC350 573
SO01844-051 401	SO51704138 409	SQ015303-LA 620	ST30-825 417	STISNS120W 574
SO02-506-5 400	SO51704138 581	SQ015304-OR 333	ST33-312 417	STISNS205 574
SO1001729 404	SO51704244 409	SQ015304-OR 620	ST33-525 418	STISSB14 574
SO1005300 401	SO51704244 581	SQ015305-FP 333	ST33-692 417	STISSB24 574
SO1005308 401	SO51704350 409	SQ015305-FP 620	ST33-716 417	STISSB26 574
SO1005314 401	SO51704350 581	SQ015308-LL 333	ST33-725 417	STISSB36 574
SO1006488 400	SO51704562 409	SQ015308-LL 620	ST33-730 417	STISSC600 573
SO1006489 400	SO51704562 581	SQ016040-LA 333	ST33-735 417	STISSM106 574
SO1007072 406	SO51704668 409	SQ016040-LA 620	ST33-740D 417	STISSP100 575
SO1020553 404	SO51704668 581	SQ016041-OR 333	ST33-799 417	STISSP4S 575
SO11-495-5 401	SO51704774 409	SQ016041-OR 620	ST33-800 417	STISSP9S 575
SO128SPRAYMASTIC-534	SO51704774 581	SQ016042-FP 333	ST33-835 418	STISSS100 575
405	SO51704880 409	SQ016042-FP 620	ST34-106 418	STISSS105 575
SO128SPRAYMASTIC-55	SO51704880 581	SQ016043-LL 333	ST34-129 417	STISSS120 575
405	SO51707212 402	SQ016043-LL 620	ST34-130 417	STISSS129 575
SO17-160-5 404	SO51707265 402	SQ016046-GR 333	ST42-465 416	STISSWBLU 574
SO25013038 403	SO51710498 406	SQ016046-GR 620	ST45-500 416	STISSWRC2 574
SO25013138 400	SO51710551 406	SQ030530-BE 333	ST46-067 416	STISSWRED 574
SO25013230 400	SO51719667 405	SQ030530-BE 619	ST46-071 416	STITC200 578
SO25013586 404	SO51719773 406	SQ030531-CI 333	ST46-222 416	STITC300 578
SO26-435-5 404	SO51719826 406	SQ030531-CI 619	ST47-480 418	STITC400 578
SO30-484-5 405	SO51721310 407	SQ030532-GR 333	ST47-973 292	STL11462 423
SO30-485-051 405	SO51721363 407	SQ030532-GR 619	ST54-016 289	STL25459 423
SO30-486-5 405	SO53354453 407	SQ030534-OR 333	ST54-024 289	STL25462 423
SO32-957 408	SO55395429 407	SQ030534-OR 619	ST54-032 289	STOFAN212131 541
SO32-957 581	SO55395482 407	SQ030535-FP 333	ST55-099 280	STOFAN214148 541
SO32-957PP 408	SO55395535 407	SQ030535-FP 619	ST55-120 280	STOFAN238120 541
SO32-961 408	SO55395588 407	SQ060100-OR 333	ST55-515 280	STOFAN238120EG 541
SO32-961 581	SO55395641 407	SQ060100-OR 620	ST57-532 289	STOFAN238120R 541
SO32-961PP 408	SO55395694 407	SQ060102-FP 333	ST57-533 289	STOFAN238120REG 541
SO32-961PP 581	SO55395747 407	SQ060102-FP 620	ST57-534 289	STOFAN312131EG 541
SO32-962 408	SO55395853 407	SQ060106-LL 333	ST62-502 264	STOFAN312162 541
SO32-962 581	SO55395906 407	SQ060106-LL 620	ST62-505 264	STOFAN3131 541
SO32-963 408	SO55395959 407	SQ060107-GR 333	ST68-012M 264	STOFAN3131EG 541
SO32-963 581	SO55403273 407	SQ060107-GR 620	ST77-115 422	STOFAN314131 541
SO32-963PP 408	SO55403379 407	Square Base 456	STCT109T 282	STOFAN314131EG 541
SO32-963PP 581	SO55405340 400	SR100100 321	STIAS205 573	STOFAN314131EG 541
SO32-964 408	SO57474990 405	SR100200 321	STIAS205R 573	STOFAN314148 541
SO32-964 581	SO648CPKIT 403	SR100844 321	STICD200 577	STOFAN3148 541
SO32-964PP 408	SO648MASTIC-42 405	SR105014 321	STICD200K 577	STOFAN34112148HTEG
SO32-964PP 581	SO648MASTIC-460 405	SR106010 321	STICD200M 577	541
SO32-964PP 581	SO648MASTIC-5 405	SR119044 321	STICD200X 577	STOFANA1138G 535
SO32-965 408	SO648MASTIC-55 405	SR140096 321	STICD300 577	STOFANAC7DREG45535
SO32-965 581	SO668BCHOCK 404	SR140105 321	STICD300K 577	STOFANB16200SS 534
SO32-965PP 408	SOEJF1240 408	SR140171 321	STICD300M 577	STOFANBMH18200SS534
SO32-965PP 581	SOEJF1254 408	SR210010 320	STICD300X 577	STOFANCR1D 535
SO32-966 408	SOEJF1256 408	SR220010 320	STICD400 577	STOFANCR2D 535



Part Number Index

STOFANCR3D.....	535	SU780472.....	156	TA542774902.....	385	TOL110-3/4-10.....	479	TOL314-18.....	481
STOFANCR4D.....	535	SU780518.....	156	TA542775594.....	384	TOL110-3/8-1-1/2.....	479	TOL314-20.....	481
STOFANCR5D.....	535	SU780650.....	158	TA542775596.....	384	TOL110-3/8-1-1/4.....	479	TOL314-22.....	481
STOFANDA17B.....	535	SU781000.....	157	TA542775597.....	384	TOL110-3/8-2.....	479	TOL314-24.....	481
STOFANDA17G.....	535	SU781050.....	157	TA542777987.....	384	TOL1-10.....	473	TOL314-26.....	481
STOFANDA21B.....	535	SU781060.....	155	TA542778735.....	384	TOL110-5/8-6.....	479	TOL314-30.....	481
STOFANDA21G.....	535	SU781061.....	155	TA542785111.....	387	TOL110-5/8-8.....	479	TOL314-32.....	481
STOFANDA25B.....	535	SU781062.....	155	TA542785112.....	387	TOL110-7/8-12.....	479	TOL314-36.....	481
STOFANDA25G.....	535	SU781130.....	157	TA542785115.....	387	TOL110-7/8-14.....	479	TOL314-4.....	481
STOFANN17G.....	535	SU781150.....	157	TA542785118.....	387	TOL110-7/8-16.....	479	TOL314-5.....	481
STPHT250C.....	280	SU781170.....	157	TA542785120.....	387	TOL1-1-1/2.....	473	TOL314-6.....	481
STR120B-12.....	420	SU781235.....	158	TA542785122.....	387	TOL1-1-1/4.....	473	TOL314-8.....	481
STR120JZ-6.....	420	SU781240.....	158	TA542785125.....	387	TOL1-1/2.....	473	TOL316-1-1/2.....	482
STR216RL-1.....	420	SU781265.....	157	TA542785128.....	387	TOL1-12.....	473	TOL316-1-1/4.....	482
STR216RL-2.....	420	SU781275.....	157	TA542785130.....	387	TOL1-14.....	473	TOL316-1.....	482
STR216RL-3.....	420	SU781285.....	157	TA542785150.....	387	TOL1-1.....	473	TOL316-2-1/2.....	482
STR216RL-4.....	420	SU781300.....	156	TA542785152.....	387	TOL1-16.....	473	TOL316-2.....	482
STR216RL-5.....	420	SU781301.....	156	TA542785154.....	387	TOL1-18.....	473	TOL316-3.....	482
STR216RL-6.....	420	SU781305.....	156	TA542785156.....	387	TOL1-20.....	473	TOL316-4.....	482
STR216XRL-1.....	420	SU781375.....	156	TA542785157.....	387	TOL1-2-1/2.....	473	TOL316-6.....	482
STR36-12.....	421	SU782699.....	158	TA542785160.....	387	TOL1-24.....	473	TOL316-8.....	482
STR36-24.....	421	SU783154.....	157	TA542785162.....	387	TOL1-2.....	473	TOL316T-1-1/2.....	482
STR36-6.....	421	SU783650.....	156	TA542785165.....	387	TOL1-30.....	473	TOL316T-1-1/4.....	482
STR37-12.....	421	SU783650.....	217	TA580601.....	385	TOL1-3-1/2.....	473	TOL316T-1.....	482
STR37-24.....	421	SU783651.....	156	TA580735.....	385	TOL1-3/4.....	473	TOL316T-2-1/2.....	482
STR3734XFL-1.....	420	SU783651.....	217	TA580736.....	385	TOL1-3.....	473	TOL316T-2.....	482
STR37-6.....	421	SU783652.....	156	TA580737.....	385	TOL1-36.....	473	TOL316T-3.....	482
STR445AZ-12RL.....	420	SU783652.....	217	TA580738.....	385	TOL1-4.....	473	TOL316T-4.....	482
STR445AZ-3RL.....	420	SU784100.....	158	TA580761.....	385	TOL1-5.....	473	TOL316T-6.....	482
STR445AZ-6RL.....	420	SU784102.....	158	TA580762.....	385	TOL1-6.....	473	TOL316T-8.....	482
STR445AZ-9RL.....	420	SU784103.....	158	TA580763.....	385	TOL1-8.....	473	TOL317-10.....	483
STR445BZ-12RL.....	420	SU784750.....	156	TA581291.....	383	TOL20-1-1/2.....	478	TOL317-1-1/2.....	483
STR445BZ-3RL.....	420	TA22984.....	382	TA621679.....	385	TOL20-1-1/4.....	478	TOL317-12.....	483
STR445BZ-6RL.....	420	TA23019.....	382	TA621715.....	385	TOL20-1/2.....	478	TOL317-14.....	483
STR445BZ-9RL.....	420	TA23020.....	382	TA772180.....	386	TOL20-1.....	478	TOL317-16.....	483
STR445DZ-12RL.....	420	TA23021.....	382	TA772182.....	386	TOL20-2-1/2.....	478	TOL317-18.....	483
STR445DZ-3RL.....	420	TA23022.....	382	TA773204.....	386	TOL20-2.....	478	TOL317-20.....	483
STR445DZ-6RL.....	420	TA23023.....	382	TA773236.....	386	TOL20-3-1/2.....	478	TOL317-2-1/2.....	483
STR445DZ-9RL.....	420	TA23024.....	382	TA773238.....	386	TOL20-3/4.....	478	TOL317-22.....	483
STR579A-12.....	421	TA23025.....	382	TA773240.....	386	TOL20-3.....	478	TOL317-24.....	483
STR579A.....	421	TA23026.....	382	TA773242.....	386	TOL20-4.....	478	TOL317-2.....	483
STR579A-8.....	421	TA23027.....	383	TC21010.....	243	TOL20-5.....	478	TOL317-26.....	483
STR579B-12.....	421	TA23028.....	383	TC21501.....	243	TOL20-6.....	478	TOL317-30.....	483
STR579B.....	421	TA23029.....	383	TC22500.....	243	TOL20-8.....	478	TOL317-3-1/2.....	483
STR579B-8.....	421	TA23030.....	383	TC22510.....	243	TOL304-1-1/2.....	480	TOL317-32.....	483
STR579C-12.....	421	TA23033.....	383	TC22666.....	243	TOL304-1-1/4.....	480	TOL317-3.....	483
STR579C.....	421	TA24511211.....	383	TC23000.....	243	TOL304-1/2.....	480	TOL317-36.....	483
STR579C-8.....	421	TA25411111.....	383	TE1361.....	225	TOL304-1-3/4.....	480	TOL317-4.....	483
STR579D-12.....	421	TA25511111.....	383	TE138-2.....	225	TOL304-1.....	480	TOL317-5.....	483
STR579D.....	421	TA40S006.....	382	TE186.....	225	TOL304-2-1/2.....	480	TOL317-6.....	483
STR579D-8.....	421	TA40S10.....	382	TG9991110.....	409	TOL304-2-1/4.....	480	TOL317-8.....	483
STR579E-12.....	421	TA504-06-72-01.....	386	TLL322-1-1/4.....	485	TOL304-2-3/4.....	480	TOL318A-10.....	484
STR579E.....	421	TA505-09-54-03.....	375	TNVDL-121836-1.....	622	TOL304-2.....	480	TOL318A-12.....	484
STR579E-8.....	421	TA505-51-03-02.....	387	TNVDL-121836-3.....	622	TOL304-3-1/2.....	480	TOL318A-14.....	484
STR579F-12.....	421	TA520031.....	383	TNVDL-121836-A.....	622	TOL304-3-1/4.....	480	TOL318A-16.....	484
STR579F.....	421	TA520032.....	383	TNVDL-121836-C.....	622	TOL304-3/4.....	480	TOL318A-18.....	484
STR579F-8.....	421	TA541201736.....	383	TNVDL-151836-1.....	622	TOL304-3.....	480	TOL318A-20.....	484
STR799A-12/300.....	421	TA541201737.....	383	TNVDL-151836-3.....	622	TOL304-3/8.....	480	TOL318A-22.....	484
STR799A-6/150.....	421	TA541400067.....	383	TNVDL-151836-A.....	622	TOL304-5/8.....	480	TOL318A-24.....	484
STR799A-8/200.....	421	TA541400070.....	383	TNVDL-151836-C.....	622	TOL304-7/8.....	480	TOL318A-26.....	484
STR799AZ-24/600.....	421	TA541404610.....	383	TNVSL-121872-1.....	622	TOL30H-1.....	478	TOL318A-30.....	484
STR799AZ-40/1000.....	421	TA542750649.....	386	TNVSL-121872-3.....	622	TOL30H-2.....	478	TOL318A-32.....	484
STR92-6.....	421	TA542750651.....	386	TNVSL-121872-A.....	622	TOL30H-3.....	478	TOL318A-36.....	484
STR92-9.....	421	TA542750653.....	386	TNVSL-121872-C.....	622	TOL30H-4.....	478	TOL318A-4.....	484
STTR250.....	281	TA542750655.....	386	TNVSL-151872-1.....	622	TOL30H-5.....	478	TOL318A-5.....	484
STTRA704T.....	281	TA542750656.....	386	TNVSL-151872-3.....	622	TOL30L-1.....	478	TOL318A-6.....	484
STTRA705T.....	281	TA542750658.....	386	TNVSL-151872-A.....	622	TOL30L-2.....	478	TOL318A-8.....	484
STTRA706T.....	281	TA542750660.....	386	TNVSL-151872-C.....	622	TOL30L-3.....	478	TOL322-10.....	485
STTRA708T.....	281	TA542750666.....	385	TNVSL-181872-1.....	622	TOL30M-0.....	478	TOL322-1-1/2.....	485
STTRA709T.....	281	TA542750667.....	385	TNVSL-181872-2.....	622	TOL30M-1.....	478	TOL322-12.....	485
SU780300.....	155	TA542761268.....	386	TNVSL-181872-A.....	622	TOL30M-2.....	478	TOL322-14.....	485
SU780301.....	155	TA542761270.....	386	TNVSL-181872-B.....	622	TOL313-10.....	481	TOL322-1.....	485
SU780302.....	155	TA542761276.....	385	TOL110-1-18.....	479	TOL313-12.....	481	TOL322-16.....	485
SU780303.....	155	TA542761412.....	385	TOL110-1-20.....	479	TOL313-2-1/2.....	481	TOL322-18.....	485
SU780351.....	158	TA542761413.....	385	TOL110-1/2-2-1/2.....	479	TOL313-2.....	481	TOL322-20.....	485
SU780360.....	157	TA542761416.....	384	TOL110-1/2-3-1/2.....	479	TOL313-3-1/2.....	481	TOL322-2-1/2.....	485
SU780362.....	157	TA542761420.....	384	TOL110-1/2-3.....	479	TOL313-3.....	481	TOL322-24.....	485
SU780375.....	156	TA542761427.....	384	TOL110-1-24.....	479	TOL313-4.....	481	TOL322-2.....	485
SU780376.....	156	TA542761431.....	384	TOL110-1/2-4.....	479	TOL313-5.....	481	TOL322-30.....	485
SU780399.....	157	TA542761433.....	384	TOL110-1/2-5.....	479	TOL313-6.....	481	TOL322-3-1/2.....	485
SU780429.....	158	TA542774540.....	383	TOL110-1-30.....	479	TOL313-8.....	481	TOL322-3.....	485
SU780430.....	158	TA542774541.....	383	TOL110-1-36.....	479	TOL314-10.....	481	TOL322-4.....	485
SU780441.....	157	TA542774593.....	384	TOL110-1/4-1/2.....	479	TOL314-12.....	481	TOL322-5.....	485
SU780443.....	157	TA542774809.....	384	TOL110-1/4-1.....	479	TOL314-14.....	481	TOL322-6.....	485
SU780471.....	156	TA542774817.....	384	TOL110-1/4-3/4.....	479	TOL314-16.....	481	TOL322-8.....	485



TOL329.....	475	TOL7-2.....	477	TR11524.....	112	TR12521.....	111	TR69555.....	272
TOL330-1-1/2.....	486	TOL7-3-1/2.....	477	TR11525.....	112	TR12522.....	111	TR69556.....	272
TOL330-1-1/4.....	486	TOL7-3/4.....	477	TR11526.....	112	TR12523.....	111	TR69558.....	272
TOL330-1-1/8.....	486	TOL7-3.....	477	TR11527.....	112	TR12524.....	111	TR69559.....	272
TOL330-1/2.....	486	TOL7-4.....	477	TR11528.....	112	TR12525.....	111	TR69560.....	272
TOL330-1-3/4.....	486	TOL7-6.....	477	TR11529.....	112	TR12526.....	111	TR69561.....	272
TOL330-1.....	486	TOL7-8.....	477	TR11530.....	112	TR12527.....	111	TR69562.....	272
TOL330-2-1/2.....	486	TPI188TASA.....	366	TR11531.....	112	TR12528.....	111	TR69563.....	272
TOL330-2-1/4.....	486	TPI188TASA.....	616	TR11532.....	112	TR12529.....	111	TR69566.....	272
TOL330-3/4.....	486	TPI198TMC.....	366	TR12201.....	115	TR12530.....	111	TR69567.....	272
TOL330-3/8.....	486	TPI198TMC.....	616	TR12202.....	115	TR12531.....	111	TR69568.....	272
TOL330-5/8.....	486	TPIMB-24-DF.....	365	TR12203.....	115	TR12532.....	111	TR69569.....	272
TOL330-7/8.....	486	TPIMB-24-DF.....	621	TR12204.....	115	TR13201.....	116	TR69570.....	272
TOL3330-2.....	486	TPIMB-30-DF.....	365	TR12205.....	115	TR13202.....	116	TR69902.....	274
TOL3HH-6.....	478	TPIMB-30-DF.....	621	TR12206.....	115	TR13203.....	116	TR69903.....	274
TOL4-10.....	474	TPIPB-36-B.....	365	TR12207.....	115	TR13204.....	116	TR69904.....	274
TOL4-1-1/2.....	474	TPIPB-36-B.....	621	TR12208.....	115	TR13206.....	116	TR69905.....	274
TOL4-1-1/4.....	474	TPIPB-36-D.....	365	TR12209.....	115	TR13207.....	116	TR69907.....	274
TOL4-1/2.....	474	TPIPB-36-D.....	621	TR12210.....	115	TR13208.....	116	TR69939.....	274
TOL4-12.....	474	TPIPB-42-B.....	365	TR12211.....	115	TR13209.....	116	TR69961.....	273
TOL4-14.....	474	TPIPB-42-B.....	621	TR12212.....	115	TR13210.....	116	TR69963.....	273
TOL4-1.....	474	TPIPB-42-D.....	365	TR12213.....	115	TR13211.....	116	TR71000.....	273
TOL4-16.....	474	TPIPB-42-D.....	621	TR12214.....	115	TR13212.....	116	TR71001.....	273
TOL4-18.....	474	TPIPB-48-B.....	365	TR12215.....	115	TR13213.....	116	TR71002.....	273
TOL4-20.....	474	TPIPB-48-B.....	621	TR12216.....	115	TR13214.....	116	TR71003.....	273
TOL4-2-1/2.....	474	TPIPB-48-D-OP.....	365	TR12217.....	115	TR13215.....	116	TR71004.....	273
TOL4-24.....	474	TPIPBS-36-B.....	365	TR12218.....	115	TR13216.....	116	TR71006.....	273
TOL4-2.....	474	TPIPBS-36-B.....	621	TR12219.....	115	TR13217.....	116	TR71007.....	273
TOL4-30.....	474	TPIPBS-36-D.....	365	TR12220.....	115	TR13218.....	116	TR71008.....	273
TOL4-3-1/2.....	474	TPIPBS-36-D.....	621	TR12221.....	115	TR13219.....	116	TR71009.....	273
TOL4-3/4.....	474	TPIPBS-42-B.....	365	TR12222.....	115	TR13220.....	116	TR71010.....	273
TOL4-3.....	474	TPIPBS-42-B.....	621	TR12223.....	115	TR13221.....	116	TR71011.....	273
TOL4-4.....	474	TPIPBS-42-D.....	365	TR12224.....	115	TR13222.....	116	TR71012.....	273
TOL4-5.....	474	TPIPBS-42-D.....	621	TR12225.....	115	TR13223.....	116	TR71013.....	273
TOL4-6.....	474	TPIPBS-48-B.....	365	TR12226.....	115	TR13224.....	116	TR71014.....	273
TOL4-8.....	474	TPIPBS-48-B.....	621	TR12227.....	115	TR13225.....	116	TR71015.....	273
TOL4A-4.....	475	TPIPBS-48-D-OP.....	365	TR12228.....	115	TR13226.....	116	TR71016.....	273
TOL4A-5.....	475	TR11404.....	114	TR12229.....	115	TR44404.....	112	TR71017.....	273
TOL4A-6.....	475	TR11405.....	114	TR12230.....	115	TR44405.....	112	TR71018.....	273
TOL4A-8.....	475	TR11406.....	114	TR12231.....	115	TR44406.....	112	TR71019.....	273
TOL6-10.....	476	TR11407.....	114	TR12232.....	115	TR44407.....	112	TR71020.....	273
TOL6-1-1/2.....	476	TR11408.....	114	TR12233.....	115	TR44408.....	112	TR71041.....	273
TOL6-1-1/4.....	476	TR11409.....	114	TR12234.....	115	TR44409.....	112	TR71043.....	273
TOL6-1/2.....	476	TR11410.....	114	TR12235.....	115	TR44410.....	112	TR71045.....	273
TOL6-12.....	476	TR11411.....	114	TR12236.....	115	TR44412.....	112	TR71046.....	273
TOL6-14.....	476	TR11412.....	114	TR12237.....	115	TR44414.....	112	TR71047.....	273
TOL6-1.....	476	TR11413.....	114	TR12238.....	115	TR44415.....	112	TR71068.....	273
TOL6-16.....	476	TR11414.....	114	TR12239.....	115	TR44416.....	112	TR71100.....	273
TOL6-18.....	476	TR11415.....	114	TR12240.....	115	TR44417.....	112	TR71101.....	273
TOL6-20.....	476	TR11416.....	114	TR12241.....	115	TR44418.....	112	TR71102.....	273
TOL6-2-1/2.....	476	TR11417.....	114	TR12242.....	115	TR44419.....	112	TR71103.....	273
TOL6-2.....	476	TR11418.....	114	TR12243.....	115	TR44420.....	112	TR71104.....	273
TOL6-3-1/2.....	476	TR11419.....	114	TR12244.....	115	TR44421.....	112	TR71105.....	273
TOL6-3/4.....	476	TR11420.....	114	TR12245.....	115	TR44424.....	112	TR71107.....	273
TOL6-3.....	476	TR11421.....	114	TR12246.....	115	TR44425.....	112	TR71108.....	273
TOL6-4.....	476	TR11422.....	114	TR12247.....	115	TR44426.....	112	TR71109.....	273
TOL6-5.....	476	TR11423.....	114	TR12248.....	115	TR44427.....	112	TR71110.....	273
TOL6-6.....	476	TR11424.....	114	TR12249.....	115	TR44428.....	112	TR71111.....	273
TOL6-8.....	476	TR11425.....	114	TR12250.....	115	TR44429.....	112	TR71112.....	273
TOL6F-1-1/2.....	476	TR11426.....	114	TR12251.....	115	TR44432.....	112	TR71113.....	273
TOL6F-1-1/4.....	476	TR11427.....	114	TR12252.....	115	TR57505.....	113	TR71114.....	273
TOL6F-1/2.....	476	TR11428.....	114	TR12253.....	115	TR57506.....	113	TR71115.....	273
TOL6F-1.....	476	TR11430.....	114	TR12254.....	115	TR57507.....	113	TR71116.....	273
TOL6F-2-1/2.....	476	TR11431.....	114	TR12255.....	115	TR57508.....	113	TR71118.....	273
TOL6F-2.....	476	TR11432.....	114	TR12256.....	115	TR57509.....	113	TR71119.....	273
TOL6F-3/4.....	476	TR11504.....	112	TR12257.....	115	TR57510.....	113	TR71141.....	273
TOL6PVC-1-1/2.....	476	TR11505.....	112	TR12258.....	115	TR57511.....	113	TR71143.....	273
TOL6PVC-1-1/4.....	476	TR11506.....	112	TR12259.....	115	TR57512.....	113	TR71145.....	273
TOL6PVC-1/2.....	476	TR11507.....	112	TR12260.....	115	TR57514.....	113	TR71146.....	273
TOL6PVC-1.....	476	TR11508.....	112	TR12504.....	111	TR57515.....	113	TR71147.....	273
TOL6PVC-2-1/2.....	476	TR11509.....	112	TR12505.....	111	TR57516.....	113	TR71497.....	274
TOL6PVC-2.....	476	TR11510.....	112	TR12506.....	111	TR57520.....	113	TR72280.....	274
TOL6PVC-3-1/2.....	476	TR11511.....	112	TR12508.....	111	TR57524.....	113	TR72281.....	274
TOL6PVC-3/4.....	476	TR11512.....	112	TR12509.....	111	TR57528.....	113	TR72282.....	274
TOL6PVC-3.....	476	TR11513.....	112	TR12510.....	111	TR57532.....	113	TR72283.....	274
TOL6PVC-4.....	476	TR11514.....	112	TR12511.....	111	TR58508.....	113	TR72284.....	274
TOL6PVC-5.....	476	TR11515.....	112	TR12512.....	111	TR58512.....	113	TR72285.....	274
TOL6PVC-6.....	476	TR11516.....	112	TR12513.....	111	TR58516.....	113	TR72286.....	274
TOL7-10.....	477	TR11517.....	112	TR12514.....	111	TR58520.....	113	TR72287.....	274
TOL7-1-1/2.....	477	TR11518.....	112	TR12515.....	111	TR58524.....	113	TR72289.....	274
TOL7-1-1/4.....	477	TR11519.....	112	TR12516.....	111	TR58528.....	113	TR92833.....	113
TOL7-1/2.....	477	TR11520.....	112	TR12517.....	111	TR58532.....	113	TR92834.....	113
TOL7-12.....	477	TR11521.....	112	TR12518.....	111	TR69550.....	272	TR92835.....	113
TOL7-1.....	477	TR11522.....	112	TR12519.....	111	TR69552.....	272	TR92836.....	113
TOL7-2-1/2.....	477	TR11523.....	112	TR12520.....	111	TR69554.....	272	TR92837.....	113

Part Number Index

www.edgecs.com



TR92838.....	113	UF30-576.....	288	UT24H12PG.....	592	UTP1012S.....	448	UTP2020.....	461
TR92840.....	113	UF30-578.....	288	UT808FL238C.....	594	UTP1023.....	449	UTP2024.....	461
TR92841.....	113	UF30-580.....	288	UT808XL238C.....	594	UTP1023S.....	448	UTP2025.....	461
TR92842.....	113	UF30-582.....	288	UT848B-PG.....	467	UTP1024S.....	448	UTP2026.....	461
TR92844.....	113	UF30-584.....	288	UT850FL175C.....	594	UTP1026.....	452	UTP2027.....	461
TR92845.....	113	UF30-592.....	288	UT850FL200C.....	594	UTP1028.....	451	UTP2028.....	461
TR92846.....	113	UF30-596.....	289	UT850FL45X.....	594	UTP1031.....	451	UTP2029.....	461
TR92847.....	113	UF30-598.....	289	UT850FL90X.....	594	UTP1036.....	451	UTP2030.....	461
TR92848.....	113	UF30-636.....	284	UT850XL175C.....	594	UTP1043A.....	455	UTP2031.....	461
TR92849.....	113	UF30-640.....	284	UT850XL200C.....	594	UTP1045.....	454	UTP2032.....	461
TR92850.....	113	UF30-646.....	284	UT850XL45X.....	594	UTP1047.....	454	UTP2033.....	461
TR92852.....	113	UF30-648.....	284	UT850XL90X.....	594	UTP1048.....	455	UTP2034.....	461
TR92853.....	113	UF30-650.....	284	UTARC175.....	594	UTP1062.....	450	UTP2035.....	461
TR92854.....	113	UF30-658.....	284	UTARC200.....	594	UTP1063.....	450	UTP2037.....	461
TR92856.....	113	UF30-664.....	284	UTC8516-L-Z.....	594	UTP1064.....	450	UTP2038.....	461
TR92860.....	113	UF30-666.....	284	UTC8516-M-Z.....	594	UTP1065.....	450	UTP2039.....	461
TR92863.....	113	UF30-670.....	284	UTC8516-S-Z.....	594	UTP1066.....	450	UTP2042.....	461
TR92864.....	113	UF40-107.....	286	UTCC-78414.....	355	UTP1067.....	450	UTP2046.....	461
TR92868.....	113	UF40-184.....	287	UTCC-78414.....	595	UTP1068.....	452	UTP2047.....	461
TR92872.....	113	UF40-191.....	286	UTDC150175LR.....	595	UTP1075.....	456	UTP2049.....	461
TR92876.....	113	UF41-126.....	287	UTDC175200LR.....	595	UTP1111.....	460	UTP2051.....	461
TR92880.....	113	UF44-000.....	287	UTDC200225LR.....	595	UTP1112.....	460	UTP2053.....	461
TR92884.....	113	UF44-106.....	287	UTDC219250LR.....	595	UTP1113.....	460	UTP2070.....	461
TR92888.....	113	UF44-124.....	287	UTDC225250LR.....	595	UTP1114.....	460	UTP2070-82.....	461
TR92896.....	113	UF44-363.....	287	UTDC250300LR.....	595	UTP1115.....	460	UTP2072.....	456
TR98136.....	274	UF45-000.....	287	UTDRAS3878-06.....	594	UTP1117.....	460	UTP2072A.....	456
TR98137.....	274	UF45-106.....	287	UTDRAS3878-06-W.....	594	UTP1118.....	460	UTP2072ASQ.....	456
TR98138.....	274	UF45-160.....	286	UTDS4875LR.....	595	UTP1119.....	460	UTP2072SQ.....	456
TR98139.....	274	UF45-161.....	287	UTDS61250LR.....	595	UTP1120.....	460	UTP2073A.....	456
TR98150.....	116	UF45-520.....	286	UTF100-1501.....	466	UTP1121.....	460	UTP2073ASQ.....	456
TR98231.....	274	UF45-657.....	286	UTF200-3827-96.....	466	UTP1123.....	460	UTP2097.....	453
TR98232.....	274	UF46-141.....	286	UTF200-3828-96.....	466	UTP1124.....	460	UTP2098.....	453
TR98233.....	274	UF47-023.....	287	UTF250PU-CN.....	465	UTP1126.....	460	UTP2099.....	453
TR98234.....	274	UF47-024.....	288	UTF375PU-CN.....	465	UTP1186.....	454	UTP2101.....	453
TR98235.....	274	UF47-138.....	288	UTF375PU-CNHD.....	465	UTP1211.....	461	UTP2223.....	455
TR98808.....	114	UF53-102.....	288	UTF500PU-CN.....	465	UTP1212.....	461	UTP2225.....	455
TR98809.....	114	UF53-103.....	288	UTF500PU-CNHD.....	465	UTP1213.....	461	UTP2235.....	453
TR98810.....	114	UF53-127.....	288	UTG600EG.....	467	UTP1214.....	461	UTP2265.....	454
TR98812.....	114	UF63-000.....	285	UTG601PG.....	467	UTP1215.....	461	UTP2324.....	450
TR98814.....	114	UF63-107.....	285	UTG613PG.....	467	UTP1217.....	461	UTP2346.....	455
TR98816.....	114	UF63-122.....	286	UTG621PG.....	467	UTP1272S.....	459	UTP2380-2.....	449
TR98820.....	114	UF63-133.....	286	UTG622PG.....	467	UTP1280W.....	463	UTP2450.....	463
TR98830.....	114	UF63-141.....	285	UTG623PG.....	467	UTP1281.....	452	UTP2458.....	457
TR99803.....	116	UF64-430.....	285	UTG631PG.....	467	UTP1325.....	453	UTP2471.....	450
TR99809.....	116	UF64-582.....	285	UTG640EG.....	467	UTP1326.....	452	UTP2473.....	455
TR99815.....	116	UF66-158.....	285	UTG6XXX.....	466	UTP1346.....	453	UTP2475.....	462
TR99836.....	116	UF77-306.....	370	UTG714-EG.....	467	UTP1354.....	460	UTP2484.....	453
TR99856.....	116	UF77-315.....	370	UTG811-AL.....	467	UTP1356.....	451	UTP2484W.....	453
TSUF-13.....	364	UF78-005.....	284	UTG827B-PG.....	467	UTP1376A.....	454	UTP2485.....	450
TU4210.....	241	UF78-202.....	286	UTG837-PG.....	467	UTP1377.....	454	UTP2521-50.....	463
TUBESAND.....	619	UF78-202.....	619	UTG860-PG.....	467	UTP1379S.....	458	UTP2535.....	462
TUFR1210C.....	241	UF79-770.....	288	UTG8FB38-30N-Z.....	595	UTP1380.....	451	UTP2536.....	462
TUFR152.....	240	UF83-154.....	284	UTG9XXX.....	467	UTP1380A.....	451	UTP2558-05.....	461
TWT0608.....	597	UFC6UPSP.....	370	UTHDA200-30-G.....	592	UTP1382.....	453	UTP2558-07.....	461
TWT0810.....	597	UR20P-2530.....	466	UTHDA200-36-G.....	592	UTP1386.....	458	UTP2558-10.....	461
TWT1012.....	597	UT010T014.....	462	UTHDA200-42-G.....	592	UTP1426.....	460	UTP2558-12.....	461
TWT1216.....	597	UT014T018.....	462	UTHDA200-48-G.....	592	UTP1427.....	460	UTP2558-15.....	461
TWT1220.....	597	UT017N022.....	462	UTHDA250-18-G.....	592	UTP1428.....	460	UTP2558-20.....	461
TWT1620.....	597	UT018T022.....	462	UTHDA250-30-G.....	592	UTP1429.....	460	UTP2558-25.....	461
TWT2030.....	597	UT024N028.....	462	UTHDA250-36-G.....	592	UTP1430.....	460	UTP2558-30.....	461
TWT2040.....	597	UT026N030.....	462	UTHDA250-42-G.....	592	UTP1431.....	460	UTP2600.....	462
UC2-2414-0010.....	80	UT14F12PG.....	592	UTHDA250-48-G.....	592	UTP1458.....	452	UTP2626.....	452
UC5-1215-0070.....	79	UT16D12-24-QP.....	592	UTHHSB25-300N-Z.....	595	UTP1499.....	452	UTP2675.....	457
UC5-6047-0010.....	79	UT16D12PG.....	592	UTHHXN037.....	449	UTP1546.....	453	UTP2749.....	459
UCCSH-100.....	80	UT16F12PG-20.....	592	UTHHXN050.....	449	UTP1651AS.....	457	UTP2750.....	459
UCEBS-125-D.....	80	UT16F12PG.....	592	UTHLKW037.....	449	UTP1657A.....	457	UTP2751.....	459
UCECO-50.....	80	UT20D12-20-QP.....	592	UTHLKW050.....	449	UTP16F.....	464	UTP2761.....	463
UF12-156.....	288	UT20D12-24-QP.....	592	UTLS410-050.....	460	UTP1704.....	464	UTP2785.....	458
UF12-157.....	288	UT20D12PG-10.....	592	UTLS500-050-120.....	460	UTP1723.....	452	UTP2786.....	458
UF16-274.....	618	UT20D12PG-12.....	592	UTM2950.....	463	UTP1726.....	451	UTP2787.....	458
UF16-345.....	619	UT20D12PG.....	592	UTNW38.....	594	UTP1737.....	455	UTP2815.....	457
UF16-400.....	618	UT20F12PG-10.....	592	UTP1000.....	444	UTP1771.....	456	UTP2815D.....	457
UF16-404.....	619	UT20F12PG-12.....	592	UTP1000HS.....	444	UTP1773.....	456	UTP2860-10VY.....	447
UF16-407.....	619	UT20F12PG-14.....	592	UTP1000T.....	444	UTP1775.....	456	UTP2860-55VY.....	448
UF16-815.....	619	UT20F12PG-20.....	592	UTP1001.....	444	UTP1777.....	456	UTP2863.....	450
UF20-164.....	285	UT20F12PG.....	592	UTP1001T.....	444	UTP1796S.....	457	UTP2864.....	450
UF20P-2200-20.....	465	UT20F12PG-8.....	592	UTP1006-1420.....	448	UTP1843.....	459	UTP2868.....	458
UF24-516.....	286	UT20P-2000-20.....	465	UTP1006T1420.....	449	UTP1873.....	451	UTP2894-37.....	458
UF30-125.....	285	UT20P-2100-20.....	465	UTP1007.....	448	UTP1941.....	450	UTP2894-50.....	458
UF30-127.....	285	UT20PU-5853.....	466	UTP1008.....	448	UTP1950.....	452	UTP2900AL.....	463
UF30-134.....	285	UT21H12PG.....	592	UTP1008T.....	449	UTP1964.....	450	UTP2901AL.....	463
UF30-138.....	285	UT22F12PG-30â€?.....	592	UTP1009.....	448	UTP1985S.....	459	UTP2902AL.....	463
UF30-362.....	285	UT22F12PG.....	592	UTP1010S.....	448	UTP1986S.....	459	UTP2903AL.....	463
UF30-567.....	288	UT24F12PG-10â€?™.....	592	UTP1010T.....	449	UTP2009.....	461	UTP2942.....	455
UF30-568.....	288	UT24F12PG.....	592	UTP1012.....	449	UTP2010.....	461	UTP2946.....	457

Spokane, WA 509-535-9841

Billings, MT 406-248-7196



UTP2947.....	457	UTSB9-CTA48-G.....	593	VBNP12DE.....	280	WE2508.....	210	WT20025.....	290
UTP2950.....	459	UTTB3A-Z.....	594	VBNP12G.....	280	WE2512.....	210	WT20030.....	290
UTP3000.....	444	UTTB3-Z.....	594	VBNP15CE.....	280	WE2516.....	210	WT20035.....	290
UTP3000T.....	445	UTTL015-Z.....	594	VBR999ML.....	277	WE2520.....	210	YA07001.....	619
UTP3001.....	445	UTTL016-Z.....	594	VBRB18.....	279	WE2524.....	210	YA08009.....	325
UTP3006-0832.....	449	UTTL017-Z.....	594	VBRCF2.....	277	WE2528.....	210	YA08009.....	618
UTP3006-1024.....	449	UTTL018-Z.....	594	VBRCM-2.....	278	WE2532.....	210	YA08011.....	325
UTP3006-1420.....	449	UTTL019-Z.....	594	VBRM2B.....	278	WE2608.....	210	YA08011.....	618
UTP3007.....	449	UTTL020-Z.....	594	VBRM2W.....	278	WE2612.....	210	YA08013.....	325
UTP3008.....	449	UTTL092-Z.....	594	VBS2.....	279	WE2616.....	210	YA08013.....	618
UTP3009.....	449	UTTL094-Z.....	594	VBSD48F.....	278	WE2620.....	210	YA08015.....	325
UTP3010.....	449	UTTL132-Z.....	594	VBTC16.....	278	WE2624.....	210	YA08015.....	618
UTP3013.....	449	UTTL133-Z.....	594	VBTC224.....	278	WE2628.....	210	YMACC-WHEEL-KI-TC350	
UTP3045.....	454	UTTWA200-36-G.....	592	VBTT1FG.....	278	WE2632.....	210	YMEF2000IS.....	349
UTP3184FPG.....	447	UTTWA200-42-G.....	592	VBV5.....	279	WE2708.....	211	YMEF-2600.....	349
UTP3184PG.....	447	UTTWA200-48-G.....	592	VG012.....	266	WE2712.....	211	YMEF30ISE.....	349
UTP3270.....	464	UTTWA250-36-G.....	592	VG07.....	264	WE2716.....	211	YMYG-2800i.....	349
UTP3280.....	464	UTTWA250-42-G.....	592	VG08.....	264	WE2720.....	211	YMYG-4000DX.....	348
UTP3300.....	445	UTTWA250-48-G.....	592	VG10CR.....	263	WE2724.....	211	YMYG-5200DX.....	348
UTP3300T.....	445	UTXDR3878-05-Z.....	594	VG10R.....	263	WE2728.....	211	YMYG-6600DEX.....	348
UTP3301.....	445	UTXKB42520-G.....	593	VG10WR.....	263	WE2732.....	211	YMYG-6600DX.....	348
UTP3370X.....	464	UTXKBSM42520-G.....	593	VG11R.....	263	WE3112.....	211	ZW4PL.....	600
UTP3380.....	464	UV32-000451-0000.....	334	VG11SP.....	263	WE3116.....	211	ZWCARRYBAG.....	599
UTP3663.....	464	UV32-000455-0000.....	334	VG18R.....	263	WE3120.....	211	ZWFR2.....	599
UTP3703.....	464	UV32-000461-0000.....	334	VG18SP.....	263	WE3124.....	211	ZWKIT-20.....	599
UTP3704.....	464	UVS1603.....	316	VG2078108.....	262	WE3128.....	211	ZWSLP2.....	599
UTP3712P.....	447	UVS1620X.....	316	VG2078110.....	262	WE3132.....	211	ZWZIPPER.....	600
UTP3712P.....	464	UVS1624.....	316	VG2078112.....	262	WE3136.....	211		
UTP4000.....	445	UVS2500C.....	317	VG2078116.....	262	WE3139.....	211		
UTP4000T.....	445	UVS2504C.....	317	VG2078120.....	262	WE3208.....	211		
UTP4006-1420.....	448	UVS3200X.....	317	VG20R.....	264	WE3212.....	211		
UTP4008.....	448	UVS3201X.....	317	VG20REP.....	264	WE3216.....	211		
UTP4010.....	448	UVS3202.....	317	VG21.....	264	WE3220.....	211		
UTP4012S.....	448	UVS3203.....	317	VG24R.....	263	WE3224.....	211		
UTP4045.....	454	UVS3204.....	317	VG2OEXT.....	264	WE3228.....	211		
UTP4100.....	446	UVS3960C.....	317	VG4LN.....	263	WE3232.....	211		
UTP4100SL.....	446	UVS468.....	317	VG4SP.....	263	WE3236.....	211		
UTP4100T.....	446	UVS477.....	317	VG51.....	264	WE3239.....	211		
UTP4280W.....	463	UVS487.....	317	VG52.....	264	WEA2208.....	208		
UTP5000.....	446	UVS501.....	317	VG5CR.....	263	WEERT-N.....	209		
UTP5000T.....	446	UVS561.....	317	VG5WR.....	263	WEERT-W.....	209		
UTP5001.....	446	UVS562C.....	317	VG6LN.....	263	WEPJ-100.....	213		
UTP5500.....	447	UVS6310X.....	316	VG6R.....	263	WEPJ-12P.....	213		
UTP5500T.....	447	UVS6311.....	316	VG6SP.....	263	WEPJ-18P.....	213		
UTP5501.....	447	UVS6312.....	316	VG7CR.....	263	WEPJ-24P.....	213		
UTP5510.....	449	UVS6313.....	316	VG7R.....	263	WEPJ-6P.....	213		
UTP5560.....	454	UVS6314.....	316	VG7WR.....	263	WEPJ-ERN.....	213		
UTP6006-0832.....	449	UVS6900X.....	317	VG8R.....	263	WEPJ-ERW.....	213		
UTP6006-0836.....	449	UVS6901X.....	317	VG91.....	264	WEPJ-PC.....	213		
UTP6006-1024.....	449	UVS6902.....	317	VG92.....	264	WEPJ-PF.....	213		
UTP6006-1032.....	449	UVS6903.....	317	VG9LN.....	263	WEPJ-SBF.....	213		
UTP6006-1420.....	449	UVS6904.....	317	VG9R.....	263	WEPJ-SBR.....	213		
UTP6026.....	465	UVS700C.....	317	VG9SP.....	263	WEPJ-SN.....	213		
UTP6917.....	465	VB222.....	279	VGWR.....	263	WEPJ-WB.....	213		
UTP7000.....	464	VB4.....	280	VXD6316.....	409	WESGR-09.....	209		
UTP7006-1420.....	449	VB57736.....	280	W5B.....	612	WESGR-13.....	209		
UTP9000.....	448	VB57748.....	280	W5BLID.....	612	WESSP-47.....	209		
UTP9200.....	448	VB707M.....	277	WAR10040.....	225	WESTB-09.....	209		
UTPCR-050.....	466	VB999.....	277	WAR10227.....	208	WESTB-13.....	209		
UTPCR-075.....	466	VB999TML.....	278	WAR10230.....	225	WEWNS2412.....	214		
UTPCR-100.....	466	VBAP22.....	279	WAR10329.....	225	WEWNS2416.....	214		
UTPCR-125.....	466	VBB215.....	279	WC.....	597	WEWNS2420.....	214		
UTPCR-150.....	466	VBB215L.....	279	WD10100.....	591	WEWNS2424.....	214		
UTPCR-200.....	466	VBBC10.....	279	WD10110.....	591	WEWNS2512.....	214		
UTRTSB-MPHDW.....	593	VBBC12.....	279	WD110054.....	591	WEWNS2516.....	214		
UTSB10-250300B-G.....	593	VBBC14.....	279	WD110078.....	591	WEWNS2520.....	214		
UTSB10-250TA-G.....	593	VBBC8.....	279	WD110108.....	591	WEWNS2524.....	214		
UTSB10-300A-G.....	593	VBBC9.....	279	WE2008.....	210	WEWNS2612.....	214		
UTSB10C-250A-G.....	593	VBBCSB.....	279	WE2012.....	210	WEWNS2616.....	214		
UTSB10-CTA30-G.....	593	VBCF1.....	277	WE2016.....	210	WEWNS2620.....	214		
UTSB10-CTA36-G.....	593	VBCF1HC.....	277	WE2020.....	210	WEWNS 2624.....	214		
UTSB10-CTA42-G.....	593	VBCF1P.....	277	WE2024.....	210	WL0390318401.....	428		
UTSB10-CTA48-G.....	593	VBCF21FG.....	278	WE2316.....	210	WL111105F.....	428		
UTSB8-250300B-G.....	593	VBCF3.....	277	WE2320.....	210	WL175MH.....	428		
UTSB8-250TA-G.....	593	VBCFB1HCM.....	277	WE2324.....	210	WL400MH.....	428		
UTSB8C-250A-G.....	593	VBCFB1LM.....	277	WE2328.....	210	WL500H.....	428		
UTSB8-CTA30-G.....	593	VBCFB21FG.....	277	WE2330.....	210	WL52230.....	428		
UTSB8-CTA36-G.....	593	VBCFB21HC.....	277	WE2332.....	210	WL85SF.....	428		
UTSB8-CTA42-G.....	593	VBCFB2HCM.....	277	WE2408.....	210	WLD052195.....	428		
UTSB8-CTA48-G.....	593	VBE18F.....	278	WE2412.....	210	WLD052197.....	428		
UTSB9-250300B-G.....	593	VBFS505.....	278	WE2416.....	210	WT19999.....	290		
UTSB9-250TA-G.....	593	VBFS505M.....	278	WE2420.....	210	WT20000.....	290		
UTSB9-CTA30-G.....	593	VBFS99.....	278	WE2424.....	210	WT20003.....	290		
UTSB9-CTA36-G.....	593	VBFS999.....	278	WE2428.....	210	WT20015.....	290		
UTSB9-CTA42-G.....	593	VBFS999ML.....	278	WE2432.....	210	WT20020.....	290		



Office Supplies

- Batteries
- Broom
- Calendar
- Carpenter pencil
- Clock
- Dust pan & brush
- Flashlight
- Hand cleaner
- Lumber crayons
- Paper towels
- Radios
- Sharpies
- Sweeping compound
- Trash bags
- Trash cans
- Watchcallit Kit
- Wipes

Rental Equipment

- Cable pullers
- Compaction
- Compressor
- Conduit benders
- Conduit bending
- Core drill
- Generator
- Hoists
- Lights
- Pipe threading
- Pump jacks
- Scaffold
- Scissor lifts
- Span planks
- Trash pumps
- Vibrators

Winter

- Gloves
- Hand warmers
- Heaters
- Hi-viz jacket
- Ice melt
- Roof Rake
- Sand bags
- Snow shovels
- Visqueen
- Yaktraks

Summer

- Bug repellent
- Cooling vest
- Cups & holder
- Electrolytes
- Fans
- Pop-up shade tent
- Shaded safety glasses
- Wasp spray
- Water
- Water cooler

Hand Tools

- Files
- Hammer
- Level
- Screwdrivers
- Shovels, picks, rakes
- Sockets
- Tape measure
- Utility knife
- Wrenches

Lighting & Power Distribution

- Connectors
- Extension cords
- Hanging lights
- Jobsite lights
- Light bulbs
- String lights
- Temporary power boxes
- Temporary power cords
- Wobble lights

Safety Supplies

- Boots
- Bucket of Safety
- Caution tape
- Debris netting
- Eyewash station
- Fire extinguisher
- First aid kit
- Flagging tape
- Flashlight
- GFCI
- Gloves
- Hard hats
- Hearing protection
- Hi-viz vests & coats
- I-beam anchor
- Lanyards
- Masks
- Raingear
- Rebar caps
- Respirators
- Retractable lifelines
- Roof anchor
- Safety fencing
- Safety glasses
- Safety harness
- Safety signs
- Spill kit
- Traffic cones
- Traffic delineators
- Water coolers

HVAC

- Duct cover
- Screws
- Snips

General Supplies

- Bolts, nuts, washers
- Brooms
- Carpet & floor protection
- Caulk
- Chain
- Chalk & snap line
- Cold-galv spray
- Cut-off abrasive wheels
- Drywall screws
- Duct tape
- Floor protection
- Form release
- Gas cans
- Hose
- Jobsite gang boxes
- Ladders
- Locks
- Nails
- Non-shrink Grout
- Rags
- Rope
- Shims
- Silt fence
- Slings & shackles
- Spray paint
- Tarps
- Tie wire
- Upside-down paint
- Utility/demo carts
- WD-40
- Wedge anchors
- Wheel barrow

Lead Abatement, Renovation & Hospital jobs

- Booties & clean suits
- Hepa vacuum
- Negative air machine
- Respirators
- Sticky mats
- Zipwall containment

Electricians

- Benders
- Cordless drills
- Hole saws
- Klein hand tools
- Portable band saws
- Tuggers

Plumbers

- Pipe stands
- Portable bandsaws
- Threaders
- Wrenches

Power Tools

- Circular saw & blades
- Cordless drill & bits
- Cut off saw & blades/abrasives
- Grinders & abrasives
- Lasers
- Pneumatic or cordless nailer/stapler
- Portable band saws
- Portable table saw & blades
- Powder actuated with pins & loads
- Reciprocating saw & blades
- Rotomhammer & carbide bits
- Vacuum

Plumber's Starter Kit (ECTOOLSET)

- AN56074, Hex key set 9 piece
- AR11-316A, 1/2" deep socket 3/8 drive
- AR11-318A, 9/16 deep socket 3/8 drive
- BZTX405, spark lighter
- CGM3R, Aircraft snips - straight
- CL337, Pliers 7"
- CL369CB, Linemen's pliers 9"
- CL420, Channellock 9-1/2"
- CL430, Pliers 10"
- CL808W, Adjustable wrench 8" - wide opening
- CL810W, Adjustable wrench 8" - wide opening
- CS1572, Soft tool box
- DTDW1956, 16 piece drill index
- EE916BR, 16oz plumb bob
- EWE3-20S, Claw hammer
- GW81218, 3/8 ratchet
- IR3057014, bit set
- KL32477, 10-in-1 screwdriver
- KL630-3/8, 3/8 nut driver
- KL630-5/16, 5/16 nut driver
- PF11023P, 8" half round file
- RI31632, Tube Cutter 1/4" to 1-5/8"
- RI31642, Tube Cutter 1/4" to 2-5/8"
- RI86127, Tube Cutter
- RYILJ2AA-B, Flashlight
- SB25245, Torpedo level 10"
- ST10-499, Utility knife
- ST15-206, 6" wallboard saw
- ST33-525, 25' tape
- ST46-222, 12" combination square

Other job start-up needs:

- Submittals on specified products
- Quote on Engineered Systems
- Other items not listed above



CSI standard formatting is used throughout the construction industry to format construction specifications in building contracts. The purpose of this industry standard format is to assist the user in locating specific types of information. The information contained in CSI's MasterFormat is organized in a standardized outline form within 16 (pre-2004) or 50 (post-2004) divisions. Each division contains a number of sections. Each section is divided into three parts: "general," "products," and "execution." Each part is organized by a standardized system of articles and paragraphs.

Post 2004 Master Format with 50 Divisions

PROCUREMENT & CONTRACTING REQUIREMENTS GROUP:
Division 00 -- Procurement & Contracting Requirements
SPECIFICATIONS GROUP:
General Requirements Subgroup
Division 01 -- General Requirements
Facility Construction Subgroup
Division 02 -- Existing Conditions
Division 03 -- Concrete
Division 04 -- Masonry
Division 05 -- Metals
Division 06 - Wood, Plastics & Composites
Division 07 -- Thermal & Moisture Protection
Division 08 -- Openings
Division 09 -- Finishes
Division 10 -- Specialties
Division 11 -- Equipment
Division 12 -- Furnishings
Division 13 -- Special Construction
Division 14 -- Conveying Equipment
Division 15 to 19 -- RESERVED FOR FUTURE EXPANSION
Facility Services Subgroup:
Division 20 -- RESERVED FOR FUTURE EXPANSION
Division 21 -- Fire Suppression
Division 22 -- Plumbing
Division 23 -- Heating Ventilating & Air Conditioning
Division 24 - RESERVED FOR FUTURE EXPANSION
Division 25 -- Integrated Automation
Division 26 -- Electrical
Division 27 -- Communications
Division 28 -- Electronic Safety & Security
Division 29 - RESERVED FOR FUTURE EXPANSION

(cont'd on next page)



Post 2004 Master Format with 50 Divisions (cont'd)

PROCUREMENT & CONTRACTING REQUIREMENTS GROUP:
SPECIFICATIONS GROUP:
Site & Infrastructure Subgroup:
Division 30 -- RESERVED FOR FUTURE EXPANSION
Division 31 -- Earthwork
Division 32 -- Exterior Improvements
Division 33 -- Utilities
Division 34 -- Transportation
Division 35 -- Waterway & Marine
Division 36 to 39 -- RESERVED FOR FUTURE EXPANSION
Process Equipment Subgroup:
Division 40 -- Process Integration
Division 41 -- Material Processing & Handling Equipment
Division 42 -- Process Heating, Cooling, & Drying Equipment
Division 43 -- Process Gas & Liquid Handling, Purification & Storage Equipment
Division 44 -- Pollution Control Equipment
Division 45 -- Industry-Specific Manufacturing Equipment
Division 46 -- Water & Wastewater Equipment
Division 47 -- RESERVED FOR FUTURE EXPANSION
Division 48 -- Electrical Power Generation
Division 49 -- RESERVED FOR FUTURE EXPANSION

Pre-2004 format with 16 Divisions

Division 1 -- General Requirements
Division 2 -- Sitework
Division 3 -- Concrete
Division 4 -- Masonry
Division 5 -- Metals
Division 6 -- Wood & Plastics
Division 7 -- Thermal & Moisture Protection
Division 8 -- Doors & Windows
Division 9 -- Finishes
Division 10 -- Specialties
Division 11 -- Equipment
Division 12 -- Furnishings
Division 13 -- Special Construction
Division 14 -- Conveying Systems
Division 15 -- Mechanical
Division 16 -- Electrical



A	
ABC	Associated Builders & Contractors
ABS	(acrylonitrile butadiene styrene) plastic pipe used for plumbing and other
AC	alternating current; electrical current which reverses direction at regular intervals due to a change in voltage which occurs at the same frequency.
A/C	air conditioning
accelerator	a concrete additive used to speed the curing time of freshly poured concrete
acoustical	refers to the study of sound transmission or features hung in buildings for aesthetic and sound reduction
adhesive	a bonding material used to join two materials together
AGC	Associated General Contractors of America
aggregate	a bonding material used to bond two materials together
AIA	American Institute of Architects
air handling unit (AHU)	a mechanical unite used for air conditionin or movement of air as in direct supply or exhaust of air within a structure
allowable load	maximum supportable load of any construction components
alternator	converts mechanical energy into electrical energy
AMP	ampere; electrical current unit
alloy steel	A mixture of ordinary steel added to other metals besides carbon with the specific purpose of attaining certain characteristics such as higher strength. A few exceptions to this definition exist, however, so that a chromium content above 4% is not considered alloy steel and above 12% is considered stainless steel.
aluminum	The most abundant metal in the earth, aluminum is blueish and silvery-white, very light, malleable, and ductile with high heat and electrical conductivity. It is non-magnetic and 1/3 the weight of steel with good corrosion resistance against certain chemicals and acids but weak resistance against other elements such as sea water.
ambient temperature	the temperature of the surroundings
ampacity	the amount of current (measured in Amps) that a conductor can carry without overheating
ampere (A)	unit of current measurement; the amount of current that will flow through a one ohm resistor when one volt is applied
anchor bolt	a J or L shaped steel rod threaded on one end for securing structural members to concrete or masonry
anneal	To heat metal in order to lower its hardness. The term anneal refers to the heat treatment given all 300 series stainless and most 400 series stainless by a steel mill after the raw material has been completed but before fasteners are manufactured. Anneal also refers to the heat treatment given 400 series stainless fasteners after their manufacture (also called hardening and tempering) to lower hardness and increase toughness. For example, fasteners of 410 stainless may score over 200,000 psi after manufacture and be too brittle. By annealing at 1000 degrees F. tensile strength would decrease to 125,000-150,000 psi; annealing the same material to 500 degrees F. would bring tensile to 160,000-190,000 psi.
ANSI	American national Standards Institute
apprentice	one who is learning by practical experience under skilled workers a trade, art, or calling
arbor	an axle on which a cutting tool is mounted; it is a common term used in reference to the mounting of a cirucular saw blade
ASHRAE	American Society of Heating, Refrigerating, & Air-Conditioning Engineers
ASME	American Society of Mechanical Engineers
asphalt	the general term for a black material produced as a by-product of oil (asphalt) or coal (pitch or coal tar)
asphalt shingle	a composition-type shingle used on a roof and made of a saturated felt paper with ground-up pieces of stone embedded and held in place by asphaltum
ASTM	American Society for Testing & Materials
AWG	American wire gauge
B	
B	Byte
b	bit
backfill	any deleterious amterial (sand, gravel and so on) used to fill an excavation
battery	a device that converts chemical energy into electrical current
beam	a horizontal framing member; may be made of steel or wood; usually refers to a wooden beam at least 5" thick & at least 2" wider than it is thick
bearing wall	a wall having weight-bearing properties associated with holding up a building's roof or upper structure
bevel	a tool that can be adjusted to any angle; it helps make cuts at the number of degrees that is desired
brace	an inclined piece of lumber applied to a wall or ro roof rafters to add structural strength
brass	The most common alloy of copper, brass is about 2/3 copper, 1/3 zinc. It is non-magnetic with good strength and toughness, high electircal conductivity, and an attractive lustrous finish. It has good corrosion resistance but not in salt water. Brass is commonly used by the electrical and communications industries, builders hardware, and some marine applications.
BTU	British thermal unit; measure of power



Glossary & Abbreviations

building codes	rules & regulations which are formulated in a code by a local housing authority or governing body
building permits	a series of permits that must be obtained for building
C	
cable	one or more insulated or non-insulated wires used to conduct electrical current
CAD	computer aided drafting
calcium chloride	a concrete admixture used for accelerating the cure time
carbon steel	Ordinary steel with no significant additions besides carbon.
casing	the trim that goes on around the edge of a door opening or window
CBC	California Building Code
caulk	any type of material used to seal walls, windows & doors to keep out the weather
cement	a material that when combined with water hardens from a chemical reaction; the basis for a concrete mix
cementitious	able to harden like cement
certificate of compliance	A certification that a fastener meets the description or standard to which it was sold.
CFM	cubic feet per minute; used to measure flow through HVAC systems & fans
chord	top or bottom member of a truss
circuit breaker	A device used to open and close a circuit by automatic means when a predetermined level of current flows through it.
CMU	concrete masonry unit When fasteners are produced without heating or small heat below the recrystallization temperature (so the raw material bond of stainless remains unchanged) by pressing metal wire against various dies at high speed to form a fastener's head or basic shape. Cold working causes an increase in tensile strength and hardness (known as work hardening) and a decrease in ductility.
cold forming or cold working	
concrete	a mixture of sand, gravel & cement in water
cross brace	wood or metal diagonal bracing used to assist in structural support between joists & beams
CSA	Canadian Standards Association
CU FT (ft^3)	cubic feet
CU IN (in^3)	cubic inches
CU YD (yd^3)	cubic yards
curtain wall	inside walls are often curtain walls; they don't carry loads from the roof or floor above them
D	
dado	a rectangular groove cut into a board across the grain
dampproofing	moisture protection; a surfacing used to coat and protect concrete and masonry from moisture penetration
DC	direct current; electrical current which flows in one direction only
DIA	diameter
DOD	Department of Defense
DOE	Department of Energy
ductility	The ability of a fastener to deform before breaking (for example, an elastic would be more ductile than a diamond). Ductility is a measurement similar to elongation.
ductwork	a system of pipes used to pass heated air along to all parts of a house; also used to distribute cold air for summer air conditioning
DWG	drawing
E	
E	east
EA	each
earthwork	excavating and grading
electromagnet	Coil of wire that exhibits magnetic properties when current passes through it.
elevation	an exterior or interior orthographic view of a structure identifying the design and the materials to be used
energy	The capacity to do work.
estimator	someone who gathers information to provide an estimate or quote for a project or item to be manufactured
EG	electro-galvanize
EIT	Engineer In Training
ELEC	electric, electrical
ELEV	elevation or elevator
EMG	Evergreen Marketing Group



F	
	F593 is a specification for stainless hex head cap screws; F594 is for stainless steel nuts. Compared to regular stainless fasteners, F593 and F594 call for: a) tensile requirements about 20% higher than that of commercial 18-8 or stainless hex caps and nuts to MS specifications (MS35307-8, MS34649-50); b) both a minimum and a maximum tensile and hardness requirements while commercial and MS fasteners do not have a maximum; c) chemical requirements that are somewhat bizarre, eliminating many commonly used mixtures of 300 or 18-8 stainless while allowing others.
F593, F594	a flat board covering the ends of rafters on the cornice or eaves; eave troughs are usually mounted to the fascia board
fascia	
fiber optics	A technology that uses light as a digital information carrier.
fire stop	a framing member used to reduce the ability of a fire's spread
firewall	any wall that is installed for the purpose of preventing the spread of fire
footcandle (fc)	The amount of light produced by a lamp measured in lumens divided by the areas that is illuminated
footing	the bottom-most member of a foundation; supports the full load of the structure above
foreman	a worker who supervises and directs other workers
form	a temporary construction member used to hold permanent materials in place
foundation	the base on which a house or building rests
FT	feet
fuse	A protective device with a fusible element that opens the circuit by melting when subjected to excessive current.
G	
GA	gauge
GALV	galvanized
galvanic corrosion	An accelerated degree of corrosion occurring when two different metals are in contact with moisture, particularly sea water. All metals have what is termed a specific electric potential, so that low level electric current flows from one metal to another. A metal with a higher position in the galvanic series will corrode sacrificially rather than one with a lower position, meaning stainless, for example, will corrode before gold. The further apart the metals on the chart, the more electric current will flow and the more corrosion will occur. No serious galvanic action will occur by combining the same metals, only dissimilar ones. To prevent galvanic corrosion, use insulation, paint or coatings when separating dissimilar metals; or put the metal to be protected next to a metal which is not important in the assembly, so it can corrode sacrificially.
galvanize	a coating of zinc primarily used on sheet metal
gauge	the thickness of metal or glass sheet material
GFCI	Ground fault circuit interrupter. An electrical device which protects personnel by detecting hazardous ground faults & quickly disconnects power from the circuit.
girder	a support for joists at one end; usually placed halfway between the outside walls and runs the length of the building
glu-lam (GLB)	glue-laminated beam made from milled 2x lumber bonded together to form a beam
grade	an existing or finished elevation in earthwork; a sloped portion of a roadway; sizing of gravel and sand; the structural classification of lumber
grade pins	steel rods driven into the ground at each surveyor's hub; a string is stretched between them at the grade indicated on the survey stakes, or a constant distance above the grade
green	uncured or set concrete or masonry; freshly cut lumber
grounding	The connection of all exposed non-current carrying metal parts to the earth.
ground fault	A condition in which current from a hot power line is flowing to the ground.
gusset	a triangular or rectangular piece of wood or metal that is usually fastened to the joint of a truss to strengthen it; used primarily in making roof trusses
gypsum	a chalk used to make wallboard; made into a paste, inserted between two layers of paper and allowed to dry; produces a plastered wall with certain fire-resisting characteristics
H	
heating element	A conductor wire that offers enough resistance to produce heat when connected to power.
HGT/HT	height
HDG	hot-dip galvanized
HP	horsepower; measure of power
HVAC	Heating, Ventilating and Air Conditioning. Term given to all heating and air conditioning systems; the mechanical portion of the CSI format, division 15
hydraulic cement	a cement that hardens under water; made by heating limestone and clay in a kiln and pulverizing the result
HWH	hot water heater
I	
IBC	International Building Code
ICC	International Code Council
ID	inside diameter
IN	inches
insulation	any material capable of resisting thermal, sound, or electrical transmission



Glossary & Abbreviations

ISO	International Organization for Standardization
J	
jam nut	A thinner nut that is "jammed" against another nut to prevent loosening.
joist	a structural horizontal framing member used for floor and ceiling support systems
journeyman	someone who completed an apprenticeship and was fully educated in a trade or craft, but not yet a master.
K	
key	a depression made in a footing so that the foundation or wall can be poured into the footing, preventing the wall or foundation from moving during changes in temperature or settling of the building
KG	kilogram; unit of weight
KM	kilometer; unit of distance
L	
ledger	structural framing member used to support ceiling and roof joists at the perimeter walls
level-transit	an optical device that is a combination of a level and a means for checking vertical and horizontal angles
LGTH	length
lithium ion	battery chemistry
live load	any movable equipment or personal weight to which a structure is subjected
load	the weight of a building
lumen	The unit used to measure the total amount of light produced by a light source.
M	
masonry	manufactured materials of clay (brick), concrete (CMU) and stone
mastic	an adhesive used to hold tiles in place; also refers to adhesives used to glue many types of materials in the building process
MAX	maximum
MECH	mechanical
mil	abbreviation for millimeters or million
mils	one thousandth of an inch
military specifications (MIL SPEC)	these are specifications that the military writes for the products it buys from the manufacturers
MISC	miscellaneous
moisture barrier	a material used for the purpose of resisting exterior moisture penetration
mortar	a concrete mix especially used for bonding masonry units
motor	A machine that develops torque on a shaft to produce work.
N	
N	north
NAWIC	National Association of Women in Construction
NEBS	National Electrical Building Standards
NEC	National Electrical Code; contains safety rules for all types of electrical installations.
NFPA	National Fire Protection Association
ni-cad	The nickel-cadmium battery (commonly abbreviated NiCd or NiCad) is a type of rechargeable battery using nickel oxide hydroxide and metallic cadmium as electrodes
nylon	Light and low in strength compared to metal fasteners, nylon is non-magnetic, good for insulation, and corrosion resistant against many chemicals.
O	
ohm	The unit of measurement of electrical resistance. One ohm of resistance will allow one ampere of current to flow through a pressure of one volt.
on center (OC)	the distance between the centers of two adjacent components
OD	outside diameter
overload protection	A device that prevents overloading a circuit or motor such as a fuse or circuit breaker.
P	
pad	in earthwork or concrete foundation work, the base materials used upon which to place the concrete footing and/or slab
parapet	an extension of an exterior wall above the line of the roof
partition	an interior wall separating two rooms or areas of building; usually non-bearing
PE	professional engineer or sometimes project engineer
penny	the unit of measure of the nails used by carpenters
PG	pre-galvanize
photovoltaic	Changing light into electricity.
pillar	a pole or reinforced wall section used to support the floor and consequently the building



plan view	a bird's eye view of a construction layout cut at 5' 0" above finish floor level
PLT	plate
PM	project manager
Portland cement	one variety of cement produced from burning various materials such as clay, shale, and limestone, producing a fine gray powder; the basis of concrete and mortar
post-tensioning	the application of stretching steel cables embedded in a concrete slab to aid in strengthening the concrete
purlin	a horizontal framing member spanning between rafters
PVC	polyvinyl chloride; a plastic material commonly used for pipe & plumbing fixtures
Q	
QTY	quantity
R	
R values	the unit that measures the effectiveness of insulation; the higher the number, the better the insulation qualities of the materials
rafter	in sloped roof construction, the framing member extending from the ridge or hip to the top plate
rebar	a reinforcement steel rod in a concrete footing
resistance	The opposition to the flow of current in an electrical circuit & is measured in Ohms.
S	
S	south
SAE	Society of Automotive Engineers
scaffolding	A temporary structure on the outside of a building, made of wooden planks and metal poles, used by workers while building, repairing, or cleaning the building.
schematic	a one-line drawing for electrical circuitry or isometric plumbing diagrams
scissor lift	
sealant	a material used to seal off openings against moisture and air penetration
seismic design	construction designed to withstand earthquakes
shear strength	Measured by the push or pull against the side of a fastener until the fastener breaks (for example, moving an object continually against the side of a screw that is protruding from a wall). As a rule of thumb, shear strength is two-thirds of tensile strength. Double sheer strength is applying a load against a fastener in two places causing the fastener to break into three pieces.
shear wall	a wall construction designed to withstand shear pressure caused by wind or earthquake
shoring	temporary support made of metal or wood used to support other components
sinker nail	a nail for laying subflooring; the head is sloped toward the shank but is flat on top
SPEC	specification
spreader	braces used across the top of concrete forms
SQ FT	square feet
SQ IN	square inches
SQ YD	square yards
STAFDA	Specialty Tools & Fasteners Distributors Association
stainless steel	With the addition of 12% chromium to iron, stainless steel is formed. The chromium protects the iron against most corrosion or red-colored rust; thus the term stainless steel. The ability of stainless to form a thin layer of protection on its outside surface, called a "passive film", is its most important characteristic is preventing corrosion.
STD	standard
string line	a nylon line usually strung tightly between supports to indicate both direction and elevation; used in checking grades or deviations in slopes or rises
structural steel	heavy steel members larger than 12 gauge identified by their shapes
strut	C-channel metal framing used in construction; comes in different configurations, gauges, and brands; typically used by sub-trades to hang piping and conduit
stud	the vertical boards (usually 2 x 4 or 2 x 6) that make up the walls of a building
T	
tamp	to pack tightly; usually refers to making sand tightly packed or making concrete mixed properly in a form to get rid of air pockets that may form with a quick pouring
tap	to put internal threads in a hole or in a nut
tensile strength	A common measure to compare the strength of a fastener. It is the load needed to pull the fastener apart. Torque is the force used in twisting, such as tightening a fastener. Torsion strength is the amount of force needed to twist a fastener apart. Both measures consider the amount of pressure applied to the fastener and the length of the wrench used in the application.
torque	
TYP	typical
U	
UL	Underwriters Laboratory



Glossary & Abbreviations

V	
v	volt; the unit of measurement of electrical pressure (force). One volt will force one ampere of current to flow through a resistance of one Ohm.
vapor barrier	the same as a moisture barrier
vibratory roller	a self powered or towed compacting device which mechanically vibrates while it rolls
W	
w	west
waterproofing	preferably called moisture protection; materials used to protect below- and on-grade construction from moisture penetration
water table	the amount of water that is present in any area; the moisture may be from rain or snow
WT/WGT	weight
Y	
YD	yard
yield	The resistance to a load pulling on the middle of a fastener until the fastener shows permanent deformation.
yield strength	The amount of pressure required to cause permanent deformity.
Z	
z	zinc
zinc	non-corrosive metal used for galvanizing other metals



Multiply	By	To Obtain
acres	43560	square feet
acres	0.001562	square miles
acre-feet	43560	cubic feet
BTU per hour	0.0002931	kilowatts
BTU per minute	0.01759	kilowatts
BTU per minute	0.02359	horsepower
bushels	1.244	cubic feet
centimeters	0.3937	inches
cubic centimeters	6.102×10^{-6}	cubic inches
cubic feet	0.02832	cubic meters
cubic feet	7.481	gallons
cubic feet	28.32	liters
cubic inches	16.39	cubic centimeters
cubic meters	35.31	cubic feet
cubic meters	1.308	cubic yards
cubic yards	0.7646	cubic meters
feet	30.48	centimeters
gallons	0.1337	cubic feet
gallons	231	cubic inches
gallons	0.003785	cubic meters
gallons	3.785	liters
gallons per minute	0.002228	cubic feet per sec
horsepower	2.544	BTU per minute
horsepower	550	foot-pounds per sec
horsepower	33000	foot-pounds per min
horsepower	1.014	horsepower (metric)
horsepower	10.7	kg calories per min
horsepower	0.7457	kilowatts
joules	0.0009478	BTU
joules	0.2388	calories
joules	10^7	ergs
joules	0.7376	foot-pounds
joules	2.778×10^{-7}	kilowatt-hours
joules	0.102	kilogram-meters
joules	1	watt-seconds
kilograms	2.205	pounds
kilometers	3281	feet
kilometers	0.6214	miles
kilowatts	56.87	BTU per minute
kilowatts	737.6	foot-pounds per sec
kilowatts	1.341	horsepower
liters	61.02	cubic inches
liters	0.2642	gallons
meters	3.281	feet
meters	39.37	inches
miles	5280	feet
miles	1.609	kilometers
ohms	10^{-6}	megohms
ohms	10^6	microhms
pounds of water	0.01602	cubic feet
pounds of water	0.1198	gallons
square feet	2.296×10^{-5}	acres
square feet	0.0929	square meters
square inches	6.452	square centimeters
square miles	640	acres
square miles	2.59	square kilometers
tons (long)	2240	pounds
tons (metric)	2205	pounds
tons (short)	2000	pounds
watts	0.05686	BTU per minute
watts	44.26	foot-pounds per min
watts	0.001341	horsepower
watts	14.34	calories per min



Fractions / Decimals / Millimeters

Fraction (in)	Decimal (in)	Millimeters
1/64	0.015625	0.397
1/32	0.031250	0.794
3/64	0.046875	1.191
1/16	0.062500	1.588
5/64	0.078125	1.984
3/32	0.093750	2.381
7/64	0.109375	2.778
1/8	0.125000	3.175
9/64	0.140625	3.572
5/32	0.156250	3.969
11/64	0.171875	4.366
3/16	0.187500	4.763
13/64	0.203125	5.159
7/32	0.218750	5.556
15/64	0.234375	5.953
1/4	0.250000	6.350
17/64	0.265625	6.747
9/32	0.281250	7.144
19/64	0.296875	7.541
5/16	0.312500	7.938
21/64	0.328125	8.334
11/32	0.343750	8.731
23/64	0.359375	9.128
3/8	0.375000	9.525
25/64	0.390625	9.922
13/32	0.406250	10.319
27/64	0.421875	10.716
7/16	0.437500	11.113
29/64	0.453125	11.509
15/32	0.468750	11.906
31/64	0.484375	12.303
1/2	0.500000	12.700
33/64	0.515625	13.097
17/32	0.531250	13.494
35/64	0.546875	13.891
9/16	0.562500	14.288
37/64	0.578125	14.684
19/32	0.593750	15.081
39/64	0.609375	15.478
5/8	0.625000	15.875
41/64	0.640625	16.272
21/32	0.656250	16.669
43/64	0.671875	17.066
11/16	0.687500	17.463
45/64	0.703125	17.859
23/32	0.718750	18.256
47/64	0.734375	18.653
3/4	0.750000	19.050
49/64	0.765625	19.447
25/32	0.781250	19.844
51/64	0.796875	20.241
13/16	0.812500	20.638
53/64	0.828125	21.034
27/32	0.843750	21.431
55/64	0.859375	21.828
7/8	0.875000	22.225
57/64	0.890625	22.622
29/32	0.906250	23.019
59/64	0.921875	23.416
15/16	0.937500	23.813
61/64	0.953125	24.209
31/32	0.968750	24.606
63/64	0.984375	25.003



Types of Fire Extinguishers

Today they are virtually standard equipment in a business or residence and are rated by the make up of the fire they will extinguish.

- Type A** To extinguish fires involving trash, cloth, paper & other wood or pulp based materials. The flames are put out by water based ingredients or dry chemicals.
- Type B** To extinguish fires involving greases, paints, solvents, gas & other petroleum based liquids. The flames are put out by cutting off oxygen & stopping the release of flammable vapors. Dry chemicals, foams & halon are used.
- Type C** To extinguish fires involving electricity. The combustion is put out the same way as with a type B extinguisher, but, most importantly, the chemical in a type C must be non-conductive to electricity in order to be safe and effective.
- Type D** To extinguish fires involving combustible metals. Please be advised to obtain important information from your local fire department on the requirements for type D fire extinguishers for your area.

Any combination of letters indicate that an extinguisher will put out more than one type of fire. A type BC will put out two types of fires. The size of the fire to be extinguished is shown by a number in front of the letter such as 100A.

Here are some basic guidelines to follow:

- By using a type ABC you will cover most basic fires.
- Use fire extinguisher with a gauge & ones that are constructed with metal. Also note if the unit is UL approved.
- Utilize more than one extinguisher & be sure that each unit is mounted in a clearly visible & accessible manner.
- After purchasing any fire extinguisher always review the basic instructions for its intended use. Never deviate from the manufacturers' guidelines. Following this simple procedure could end up saving lives.

Decibel Levels of Sounds

The definition of sound intensity is energy transmitted per one second over a square centimeter surface. Sounds are measured in decibels. A decibel (db) change of 1 is the smallest change detected by humans.

Hearing Intensity	Decibel Level	Examples of Sounds
Barely Audible	0	Dead silence
		Audible hearing threshold
Very Light	10	Room (sound proof)
	20	Empty auditorium
		Ticking of a stopwatch
Audible light		Soft whispering
	30	People talking quietly
	40	Quiet street noise without autos
	45	Telephone operator
Medium	50	Fax machine in office
	60	Close conversation
Loud	70	Stereo system
		Computer printer
	80	Fire truck/ambulance siren
Extremely Loud		Cat/dog fight
	90	Industrial machinery
		High school marching band
Damage possible	100	Heavy duty grinder in a machine/welding shop
		Begins ear damage
Damaging	100+	Diesel engine of a train
	110	Lightning strike
	120	60 ton metal forming factory press
	130	60 in fan in a bus vacuum system
Ear Drum shattering	140	Commercial/military jet engine
	194	Space shuttle engines
	225	16 in guns on a battleship

Sound Awareness & Safety

The typical range of human hearing is 30 hertz - 15000 hertz. Human hearing recognizes an increase of 20 decibels, such as a stereo sound level increase, as being four times as loud at the higher level than it was at the lower level.

Awareness in Human Hearing	Decibel Change
Noticeably louder	10
Easily audible	5
Faintly audible	3

Hearing Protection Levels

Because of the Occupational Safety & Health Act of 1970, hearing protection is mandatory if the following time exposures to decibel levels are exceeded because of possible damage to human hearing.

Decibel Level	Time Exposure per Day
115	15 min
110	30 min
105	1 hr
102	1 1/2 hr
100	2 hr
97	3 hr
95	4 hr
92	6 hr
90	8 hr



1503 E Riverside
 PO Box 3437
 Spokane WA 99220
 (509) 535-9841 – phone
 (509) 534-3139 – fax

APPLICATION FOR CREDIT

Acct #	
Credit Limit	
Class	Branch #
Sales Rep #	ER

Company Name Credit Limit Requested

Mailing Address Phone ()
Street City State Zip

Business Address Phone ()
Street City State Zip

Business License # Federal ID # Fax ()

E-mail Address

Contractors Bond # Type of Business:

Bond Company If in Oregon CBC #

Type of Business Corporation Partnership Individual Government

As Applicable, List name(s) and Address(es) or Corporate Officers, Partners, or Owners:

Name Social Security #
Please print

Home Address Phone ()
Street City State Zip

Name Social Security #
Please print

Home Address Phone ()
Street City State Zip

Name Social Security #
Please print

Home Address Phone ()
Street City State Zip

Name of Person Responsible for Accounts Payable

Date Business Established # of Employees
 # of Years at Present Location

Name of Bank Branch Checking Acct #

Have You Ever Filed Bankruptcy? No Yes
 Under What Name? Date

Which Edge Construction Supply branch do you most often do business with?

- Billings Boise Eugene Gillette
- Idaho Falls Medford Spokane Yakima

*If out of town contractor, what local job

Local Job Address
Street City State Zip

Local Job phone / Pager # Fax #

Local Job Contact

Trade References:

(Must include complete address with zip code, area code and phone number)

Company _____ Phone (____) _____
 Address _____
 Street City State Zip Fax (____) _____

Company _____ Phone (____) _____
 Address _____
 Street City State Zip Fax (____) _____

Company _____ Phone (____) _____
 Address _____
 Street City State Zip Fax (____) _____

Account Agreement

In accordance with the Fair Credit Reporting Act, Public Law 9-508, Edge Construction Supply, ("Edge") may contact any banks and trade references and make all other credit inquiries it deems necessary and applicant authorizes the release of information to Edge. The information in the application is true and correct. Parties hereby agree that all purchases made are subject to the following terms and conditions as well as any terms and conditions stated on the invoices.

1. All sales will be C.O.D. until credit application is approved.
2. The undersigned applicant agrees that the terms of sale are net 30 days. If applicant fails to pay any invoices when due, applicant agrees to pay a late charge of 1½% per month or the maximum rate allowed by law, on any past due balance. Amounts are paid when Edge physically receives them, and not when they are deposited in the mail. If any amount owing to Edge is not paid when due, Edge may at its option: place the account on a cash basis, terminate any unfilled orders or discontinue any deliveries until all past-due payments are made and adequate assurance of applicant's financial ability is received.
3. In case of default in relation to this agreement, the undersigned shall be responsible for all costs of collection, court costs, and/or attorney fees.
4. The undersigned applicant is obligated to pay for all goods purchased regardless of whether the applicant receives any payments due him for the subsequent sale of the goods. Invoices are not payable in installments, but are payable in full as stated in paragraph (2) above.
5. The undersigned applicant agrees to notify in writing any discrepancies in billing within 10 days of receipt of the invoice or statement. Applicant further agrees to notify Edge, of any defects, overstock, damages, non-conforming goods, or any other reason that would cause applicant to reject goods shipped by Edge within 7 business days of receipt of goods. Applicant's sole and exclusive remedy is replacement of the non-conforming goods or refund of the applicant's payment at Edge's sole option.
6. Edge may apply payments in its sole discretion unless applicant clearly indicates how funds are to be applied.
7. If applicant is a sole proprietorship or partnership, I (we) agree that in the event of incorporation, all terms of the agreement will apply to the corporation, including applicant's personal guarantee, unless applicant expressly notifies holder otherwise. Applicant shall notify seller at least 30 days prior to any change in its business structure, including the conversion from sole-proprietorship or partnership to a Corporation or Limited Liability Company ("LLC"). Notification shall be made in writing and mailed to the corporate offices of Edge Construction Supply, PO Box 3437, Spokane, WA 99220 by certified mail.
8. Any change in applicant's business structure shall not affect applicant's obligations under this agreement unless Edge agrees otherwise in writing. Applicant cannot transfer or assign the account relationship without Edge's prior written consent.

By signing here you agree to the terms on behalf of the applicant, which may be you.

Signature _____ Title _____

Print Name _____ Date _____

Signature _____ Title _____

Print Name _____ Date _____

CONTINUING PERSONAL GUARANTEE

To induce Edge Construction Supply Inc., to extend credit to the above named applicant and in consideration thereof, the undersigned, and if more than one, each of them jointly and severally, unconditionally personally guarantee the obligations of applicant to Edge including but not limited to the prompt payment of all present and future indebtedness, whether secured or unsecured and regardless of how the indebtedness is represented or incurred. The undersigned consents to any extension or alteration of any obligation and guarantees such without prior notice, demand or pursuit of remedies against the party primarily liable. This shall be an open, unlimited and continuing guarantee in effect until the undersigned has notified the creditor in writing of its cancellation, even in the event that applicant shall incorporate, but such cancellation shall not alter any obligation of the undersigned arising hereunder prior to receipt of such written notice. The undersigned further agrees to pay all reasonable costs, expenses, and attorney's fees incurred in the enforcement of this continuing guarantee, or in the enforcement of any obligation as a result of the extension of credit including but not limited to the collection of any past due indebtedness whether or not suite is filed. This agreement shall bind the heirs and personal representatives of the undersigned.

Further, the undersigned hereby consent(s) to Edge's use of a non-business consumer credit report on the undersigned in order to further evaluate the credit worthiness of the undersigned as principal(s), proprietor(s) and/or guarantor(s) in connection with the extension or continuation of the business credit as contemplated by this credit application. The undersigned hereby authorize(s) Edge to utilize a consumer credit report on the undersigned from time to time in connection with the extension or continuation of the business credit represented by the credit application. The undersigned as [an] individual(s) hereby knowingly consent(s) to the use of such credit report consistent with the Federal Fair Credit Reporting Act as contained in 15.U.S.C @ 1681 et seq.

By signing here you are agreeing to be a personal guarantor.

I personally guarantee payment of this account as set forth above on behalf of my marital community.

Signature _____ Title _____

Print Name _____ Date _____

I personally guarantee payment of this account as set forth above on behalf of my marital community.

Signature _____ Title _____

Print Name _____ Date _____

YOU MUST COMPLETE AND SIGN THIS TAX EXEMPTION CARD TO AVOID BEING TAXED ON YOUR PURCHASES.

RESALE CERTIFICATE

1. Name of Seller _____
2. Name of Buyer _____
3. Address of Buyer _____
4. Buyer's UBI/Revenue Registration Number _____
5. Buyer is in the business of _____
6. Type of items purchased for resale _____
7. I certify that I am purchasing the items listed on line 6 for resale in the regular course of business without intervening use.
8. I acknowledge that I am solely responsible for purchasing within the categories listed on line 6.
9. I acknowledge that misuse of the resale privilege claim by use of this certificate subjects the buyer to a penalty of 50 percent of the tax due, in addition to the tax, interest, and any other penalties imposed by the law.
10. Signature _____
11. Print name _____
12. Date _____

Do you require purchase orders?
 Yes No

Do you wish to accept backorders?
 Yes No

Do you wish to have prices printed on your sales orders?
 Yes No

Do you require monthly statements?
 Yes No

SOLUTIONS BEYOND THE SURFACE

PFERD

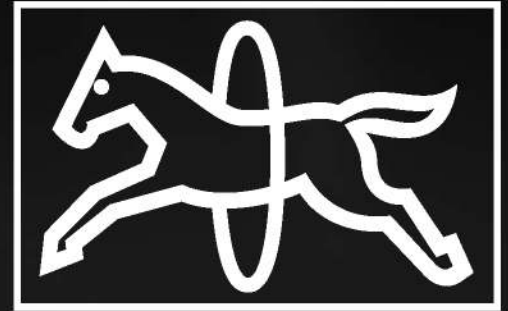

PRODUCTS AVAILABLE:

- FILES
- BURS
- HOLE SAWS
- MOUNTED POINTS
- COATED ABRASIVES
- NON-WOVEN ABRASIVES
- POLISHING WHEELS & PASTES
- CUT-OFF WHEELS
- GRINDING WHEELS
- POLIFAN® FLAP DISCS
- POWER BRUSHES
- MAINTENANCE BRUSHES
- POWER TOOLS



USER BENEFITS:

- INNOVATIVE SOLUTIONS
- PROCESS IMPROVEMENT
- PERFORMANCE
- SAFETY
- QUALITY
- CONSISTENCY
- TECHNICAL SUPPORT
- KNOWLEDGE
- TRAINING

*Ask your Edge Construction Sales Person
about PFERD Solutions Beyond the Surface!*





Construction Supply

RENTAL

SALES

REPAIR

ENGINEERING

TRAINING

» Power Tools

» Mechanical

» Electrical

» Material Handling

» Storage

» Ladders

» Scissor Lifts

» Hand Tools

» Concrete Products

» Safety

» Telespar

» Unistrut

» Anchors

» Firestop

» Maintenance



SPOKANE

800-348-4808

509-535-9841

509-534-3139 (fax)

BILLINGS

800-272-7196

406-248-7196

406-248-7269 (fax)

BOISE

800-528-5118

208-377-0158

208-377-0978 (fax)

IDAHO FALLS

208-522-7082

208-529-5456 (fax)

EUGENE

800-944-0165

541-342-3641

541-343-1753 (fax)

GILLETTE

800-670-6851

307-682-8522

307-682-8576 (fax)

MEDFORD

800-871-3919

541-779-0187

541-773-4599 (fax)

YAKIMA

800-243-5582

509-248-1144

509-575-4696 (fax)